



# CHAPTER 19

## Voice Security

---

**Last revised on: June 4, 2010**

This chapter presents guidelines and recommendations for securing IP Telephony networks. Following the guidelines in this chapter does not guarantee a secure environment, nor will it prevent all penetration attacks on a network. You can achieve reasonable security by establishing a good security policy, following that security policy, staying up-to-date on the latest developments in the hacker and security communities, and maintaining and monitoring all systems with sound system administration practices.

The security guidelines presented in this chapter pertain specifically to IP Telephony technology and the voice network. For more information on data network security, refer to the Cisco SAFE Blueprint documentation available at

[http://www.cisco.com/en/US/netsol/ns744/networking\\_solutions\\_program\\_home.html](http://www.cisco.com/en/US/netsol/ns744/networking_solutions_program_home.html)

This chapter addresses centralized but not distributed call processing, and it includes clustering over the WAN but not local failover mechanisms such as Survivable Remote Site Telephony (SRST). This chapter assumes that all remote sites have a redundant link to the head-end or local call-processing backup in case of head-end failure. The interaction between Network Address Translation (NAT) and IP Telephony, for the most part, is not addressed here. This chapter also assumes that all networks are privately addressed and do not contain overlapping IP addresses.

## What's New in This Chapter

[Table 19-1](#) lists the topics that are new in this chapter or that have changed significantly from previous releases of this document.

**Table 19-1** *New or Changed Information Since the Previous Release of This Document*

<b>New or Revised Topic</b>	<b>Described in:</b>
Network virtualization	<a href="#">Securing Network Virtualization, page 19-45</a>

# General Security

This section covers general security features and practices that can be used to protect the voice data within a network.

## Security Policy

This chapter presumes that your enterprise already has a security policy in place. Cisco Systems recommends that you do not deploy any technology without an associated security policy. The security policy defines which data in your network is sensitive so that it can be protected properly when transported throughout the network. Having this security policy helps you define the security levels required for the types of data traffic that are on your network. Each type of data may or may not require its own security policy.

If no security policy exists for data on the company network, you should create one before enabling any of the security recommendations in this chapter. Without a security policy, there is no way of telling if the security that is enabled in a network is doing what it is designed to accomplish. Without a security policy, there is also no systematic way of enabling security for all the applications and types of data that run in a network.

**Note**

---

While it is important to adhere to the security guidelines and recommendations presented in this chapter, they alone are not sufficient to constitute a security policy for your company. You must define a corporate security policy before implementing any security technology.

---

This chapter details the features and functionality of a Cisco Systems network that are available to protect the voice data on a network. It is up to the security policy to define which data to protect, how much protection is needed for that type of data, and which security techniques to use to provide that protection.

One of the more difficult issues with a security policy that includes IP Telephony is combining the security policies that usually exist for both the data network and the traditional voice network. Ensure that all aspects of the integration of the voice data onto the network are secured at the correct level for your security policy or corporate environment.

The basis of a good security policy is defining how important your data is within the network. Once you have ranked the data according to its importance, you can decide how the security levels should be established for each type of data. You can then achieve the correct level of security by using both the network and application features.

In summary, you can use the following process to define a security policy:

- Define the data that is on the network.
- Define the importance of that data.
- Apply security based on the importance of the data.

## Security in Layers

This chapter starts at the phone port that a user can plug a PC into, and it works its way through the network from the phone to the access switch, to the distribution layer, into the core, and then into the data center. (See [Figure 19-1](#).) We build layer upon layer of security, starting at the access port into the network itself. With each feature or function that is discussed, we list advantages and disadvantages that need to be taken into account from the standpoint of your corporate security policy.

For example, [Figure 19-1](#) shows both the advantage and disadvantage of using an IP Telephony network. The voice products can be placed anywhere in a network because they use IP to connect to all those devices. This feature gives a network designer the ability to place the devices where it is both physically and logically easy to deploy IP Telephony applications. But because of this ease of deployment, the security complexity increases because the IP Telephony devices can be placed anywhere in a network as long as they have connectivity.

**Figure 19-1** Layers of Security

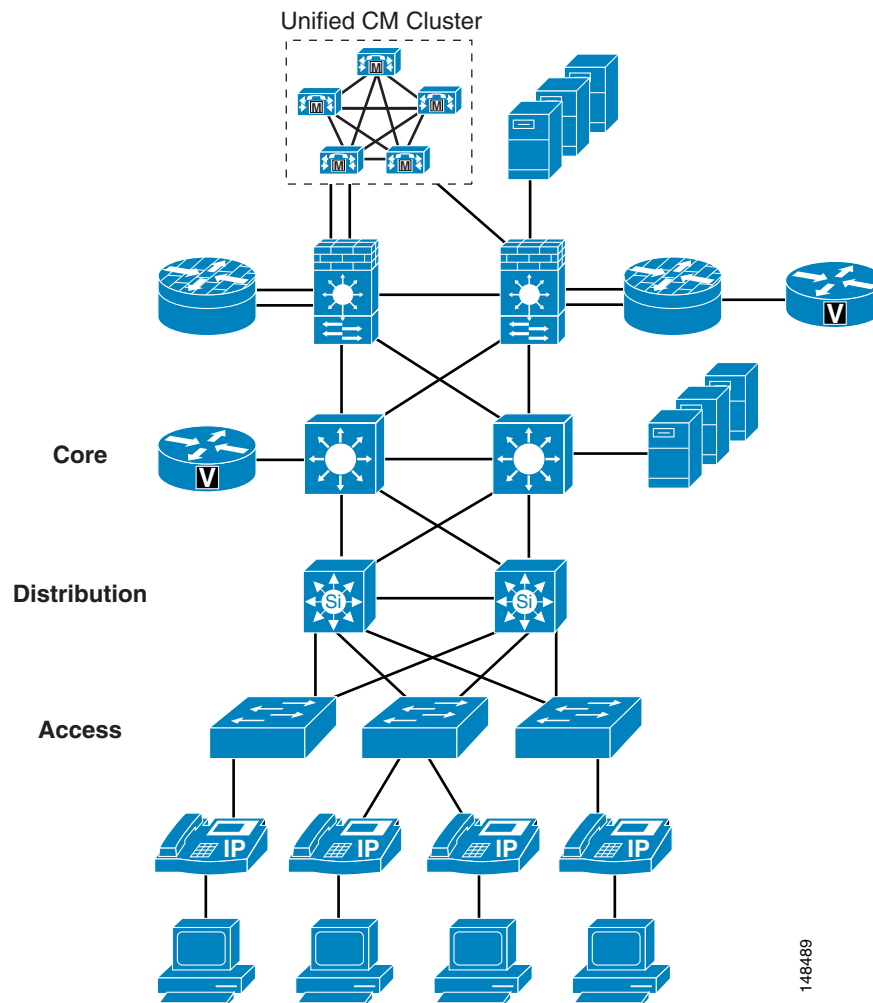

## Secure Infrastructure

As the IP Telephony data crosses a network, that data is only as safe and secure as the devices that are transporting the data. Depending on the security level that is defined in your security policy, the security of the network devices might have to be improved or they might already be secure enough for the transportation of IP Telephony traffic.

There are many best-practices within a data network that, if used, will increase the entire security of your network. For example, instead of using Telnet (which sends passwords in clear text) to connect to any of the network devices, use Secure Shell (SSH, the secure form of Telnet) so that an attacker would not be able to see a password in clear text. There are many documents on the Cisco.com website that talk about overall security within a network. Use that documentation along with your security policy to determine what security the infrastructure needs.

### Video Infrastructure

The Cisco IOS feature sets that provide the gatekeeper functionality (that is, the IP/H323 and EnterprisePlus/H323 MCU feature sets) support only Telnet and not Secure Shell (SSH). Cisco recommends that you use access control lists (ACLs) to control who is permitted to connect to the routers using Telnet, and that you always try to connect to the gatekeeper from a host that is in a secure segment of the network, because user names and passwords are sent over Telnet in clear text.

Cisco Unified Videoconferencing 3500 Series MCUs and H.320 gateways support Telnet, FTP, HTTP, and SNMP. These IP/VC devices do not support TACACS or RADIUS authentication, and only a limited number of administrative accounts can be configured locally in the device. User names and passwords are sent via clear text in all Telnet, FTP, HTTP, and SNMP communications. Cisco recommends that you access these devices from a host that is in a secure segment of the network. You should also use firewalls, access control lists, Cisco Authentication Proxy, and other Cisco security tools to help protect these devices from unauthorized access.

The following links list just a few of the security documents available on Cisco.com:

- Best Practices for Cisco Switches (login authentication required)  
[http://cisco.com/en/US/partner/products/hw/switches/ps663/products\\_tech\\_note09186a0080094713.shtml](http://cisco.com/en/US/partner/products/hw/switches/ps663/products_tech_note09186a0080094713.shtml)
- Cisco SAFE: A Security Blueprint for Enterprise Networks  
[http://www.cisco.com/en/US/prod/collateral/wireless/wirelssw/ps1953/product\\_implementation\\_design\\_guide09186a00800a3016.pdf](http://www.cisco.com/en/US/prod/collateral/wireless/wirelssw/ps1953/product_implementation_design_guide09186a00800a3016.pdf)

## Physical Security

Just as a traditional PBX is usually locked in a secure environment, the IP network should be treated in a similar way. Each of the devices that carries IP Telephony traffic is really part of an IP PBX, and normal general security practices should be used to control access to those devices. Once a user or attacker has physical access to one of the devices in a network, all kinds of problems could occur. Even if you have excellent password security and the user or attacker cannot get into the network device, that does not mean that they cannot cause havoc in a network by simply unplugging the device and stopping all traffic.

For more information on general security practices, refer to the documentation at the following locations:

- [http://www.cisco.com/en/US/netsol/ns744/networking\\_solutions\\_program\\_home.html](http://www.cisco.com/en/US/netsol/ns744/networking_solutions_program_home.html)
- [http://www.cisco.com/en/US/products/svcs/ps2961/ps2952/serv\\_group\\_home.html](http://www.cisco.com/en/US/products/svcs/ps2961/ps2952/serv_group_home.html)

## IP Addressing

IP addressing can be critical for controlling the data that flows in and out of the logically separated IP Telephony network. The more defined the IP addressing is within a network, the easier it becomes to control the devices on the network.

As stated in other sections of this document (see [Campus Access Layer, page 3-4](#)), you should use IP addressing based on RFC 1918. This method of addressing allows deployment of a IP Telephony system into a network without redoing the IP addressing of the network. Using RFC 1918 also allows for better control in the network because the IP addresses of the voice endpoints are well defined and easy to understand. If the voice endpoints are all addressed within a 10.x.x.x. network, access control lists (ACLs) and tracking of data to and from those devices are simplified.

### Advantages

If you have a well defined IP addressing plan for your voice deployments, it becomes easier to write ACLs for controlling the IP Telephony traffic and it also helps with firewall deployments.

Using RFC 1918 enables you easily to deploy one VLAN per switch, which is a best-practise for campus design, and also enables you to keep the Voice VLAN free of any Spanning Tree Protocol (STP) loops.

If deployed correctly, route summarization could help to keep the routing table about the same as before the voice deployment, or just slightly larger.

### Disadvantages

Routing tables could become large if not designed correctly or if route summarization is not used.

## Phone Security

Cisco Unified IP Phones contain built-in features to increase security on a IP Telephony network. These features can be enabled or disabled on a phone-by-phone basis to increase the security of an IP Telephony deployment. Depending on the placement of the phones, a security policy will help determine if these features need to be enabled and where they should be enabled. (See [Figure 19-2](#).)

**Figure 19-2 Security at the Phone Level**

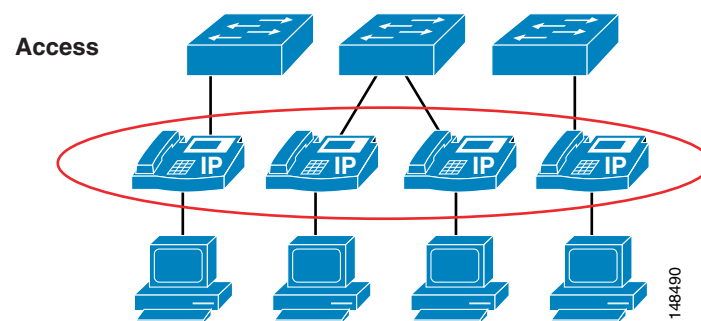

Before attempting to configure the security features on a phone, check the documentation at the following link to make sure the features are available on that particular phone model:

[http://www.cisco.com/en/US/products/sw/voicesw/ps556/products\\_administration\\_guide\\_chapter09186a00803fe693.html](http://www.cisco.com/en/US/products/sw/voicesw/ps556/products_administration_guide_chapter09186a00803fe693.html)

## PC Port on the Phone

The phone has the ability to turn on or turn off the port on the back of the phone, to which a PC would normally be connected. This feature can be used as a control point to access the network if that type of control is necessary.

Depending on the security policy and placement of the phones, the PC port on the back of any given phone might have to be disabled. Disabling this port would prevent a device from plugging into the back of the phone and getting network access through the phone itself. A phone in a common area such as a lobby would typically have its port disabled. Most companies would not want someone to get into the network on a non-controlled port because physical security is very weak in a lobby. Phones in a normal work area might also have their ports disabled if the security policy requires that no device should ever get access to the network through a phone PC port. Depending on the model of phone deployed, Cisco Unified Communications Manager (Unified CM) can disable the PC port on the back of the phone. Before attempting to enable this feature, check the documentation at the following link to verify that this feature is supported on your particular model of Cisco Unified IP Phone:

[http://www.cisco.com/en/US/products/hw/phones/ps379/tsd\\_products\\_support\\_series\\_home.html](http://www.cisco.com/en/US/products/hw/phones/ps379/tsd_products_support_series_home.html)

### Advantages

Disabling the phone PC port allows for phones to be placed in areas where network access from the phone should not be allowed. It controls access to the network that otherwise would be there if the PC port on the back of the phone was enabled.

### Disadvantages

For each person who needs to have network access and is approved for access, a separate Ethernet port would be required to provide that person with network access if the PC port on the phone is disabled. A person could still unplug the ethernet jack from the phone and attempt to plug it into another device.

For Cisco Unified Video Advantage to operate properly, the PC port and Video Capabilities must both be enabled. The other settings can safely be disabled.

## Gratuitous ARP

Just like any other data device on the network, the phones are vulnerable to traditional data attacks. The phones have features to prevent some of the common data attacks that can occur on a corporate network. One such feature is Gratuitous ARP (Gratuitous Address Resolution Protocol, or GARP). This feature helps to prevent man-in-the-middle (MITM) attacks to the phone. A MITM attack involves an attacker who tricks an end station into believing that he is the router and tricks the router into believing that he is the end station. This scheme makes all the traffic between the router and the end station travel through the attacker, thus enabling the attacker to log all of the traffic or inject new traffic into the data conversation.

Gratuitous ARP helps protect the phones from having an attacker capture the signaling and RTP voice streams from the phone if the attacker was able to get onto the voice segment of the network. This feature protects only the phones; it does not protect the rest of the infrastructure from a Gratuitous ARP attack. This feature is of less importance if you are running a Cisco infrastructure because the switch port provides features that protect both the phones and the network gear. For a description of these switch port features see the section on [Switch Port](#), page 19-12.

### Advantages

The Gratuitous ARP feature protects the phone from a traditional MITM attack on the signaling and RTP voice streams that are sourced from the phone to the network.

### Disadvantages

The downstream signaling and RTP voice streams coming from another phone or coming across the network are not protected by this feature in the phone. Only the data coming from the phone that has this feature enabled is protected. (See Figure 19-3.)

If the default gateway is running Hot Standby Router Protocol (HSRP), if the HSRP configuration uses the burned-in MAC address rather than the virtual MAC address for the default gateway, and if the primary router fails-over to a secondary router that has a new MAC address, the phones could maintain the old MAC address of the default gateway. This scenario could cause an outage for up to 40 minutes. Always use the virtual MAC address in an HSRP environment to avoid this potential problem.

**Figure 19-3** Gratuitous ARP Protects the Phone that Has It but Not Other Traffic

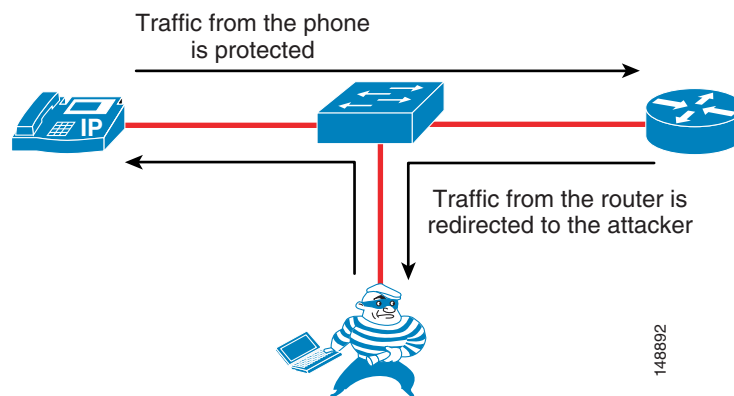

As shown in Figure 19-3, the traffic from the phone that has Gratuitous ARP is protected, but the attacker could still see the traffic coming from another endpoint because that endpoint might not have the ability to protect the data flow.

## PC Voice VLAN Access

Because there are two VLANs from the switch to the phone, the phone needs to protect the voice VLAN from any unwanted access. The phones can prevent unwanted access into the voice VLAN from the back of the phone. A feature called PC Voice VLAN Access prevents any access to the voice VLAN from the PC port on the back of the phone. When disabled, this feature does not allow the devices plugged into the PC port on the phone to "jump" VLANs and get onto the voice VLAN by sending 802.1q tagged information destined for the voice VLAN to the PC port on the back of the phone. The feature operates one of two ways, depending on the phone that is being configured. On the more advanced phones, the phone will block any traffic destined for the voice VLAN that is sent into the PC port on the back of the phone. In the example shown in Figure 19-4, if the PC tries to send any voice VLAN traffic (with an 802.1q tag of 200 in this case) to the PC port on the phone, that traffic will be blocked. The other way this feature can operate is to block all traffic with an 802.1q tag (not just voice VLAN traffic) that comes into the PC port on the phone.

Currently, 802.1q tagging from an access port is not normally used. If that feature is a requirement for the PC plugged into the port on the phone, you should use a phone that allows 802.1q tagged packets to pass through the phone.

Before attempting to configure the PC Voice VLAN Access feature on a phone, check the documentation at the following link to make sure the feature is available on that particular phone model:

[http://www.cisco.com/en/US/products/hw/phones/ps379/tsd\\_products\\_support\\_series\\_home.html](http://www.cisco.com/en/US/products/hw/phones/ps379/tsd_products_support_series_home.html)

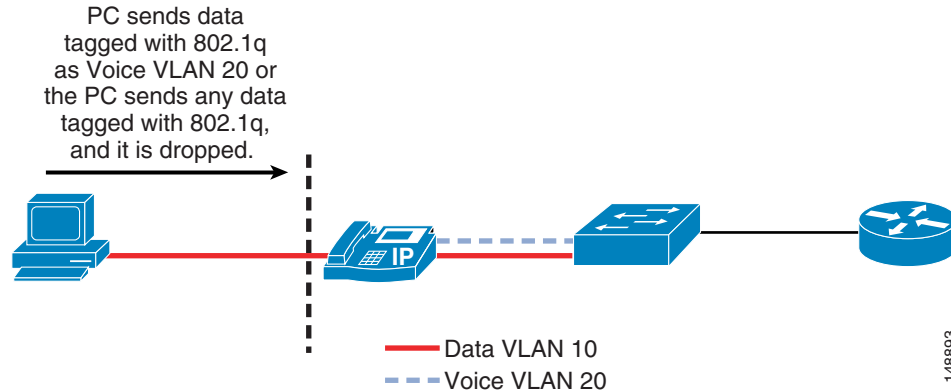
**Figure 19-4** Blocking Traffic to the Voice VLAN from the Phone PC Port**Advantages**

The PC Voice VLAN Access feature prevents attackers from sending uncontrolled data into the voice VLAN through the PC port on the back of the phone.

**Disadvantages**

If the device plugged into the phone is normally allowed to send 802.1q tagged packets, then these packets will be dropped. Most end stations are not allowed to perform this function at the access layer. If that function is considered normal operation within a network, this feature would not allow that function to work.

## Web Access

Each Cisco Unified IP Phone has a web server built into it to help with debugging and remote status of the phone for management purposes. The web server also enables the phones to receive applications pushed from Cisco Unified Communications Manager (Unified CM) to the phones. Access to this web server can be enabled or disabled on a phone by means of the Web Access feature in the Unified CM configuration. This setting can be global, or it could be enabled or disabled on a phone-by-phone basis.

**Advantages**

With Web Access enabled on the phones, the phones can be used to assist in debugging issues with a phone or within the network. If Web Access from the phone is disabled, users or an attacker cannot get information from the phone about the IP Telephony network.

**Disadvantages**

If Web Access from the phone is disabled, debugging network or IP Telephony issues can be more difficult. If the web server is globally disabled but it is needed to help with debugging, then the administrator for Unified CM will have to enable this feature on the phones. The ability to get to this web page can be controlled by an ACL in the network, leaving network operators with the capability to get to the web page when needed.

With the Web Access feature disabled, the phones will be unable to receive applications pushed to them from Unified CM.

## Video Capabilities

For Cisco Unified Video Advantage to operate properly, the PC port and Video Capabilities must both be enabled. The other settings can safely be disabled. The Device Security Mode operates as specified, even when Cisco Unified Video Advantage is in use, but Cisco Unified Video Advantage itself does not support authentication or encryption of the Cisco Audio Session Tunnel (CAST) protocol or its RTP media traffic. When an IP Phone is in Authenticated mode, the Skinny Client Control Protocol (SCCP) signaling between the phone and Unified CM will be authenticated, but the CAST signaling between the phone and Cisco Unified Video Advantage will not be authenticated. Likewise, when a phone is in Encrypted mode, the audio stream between the phones will be encrypted, but the video streams between the Cisco Unified Video Advantage clients will not be encrypted. Users should be notified that the video channel is not encrypted even though an icon on the phone appears to indicate that they are in an encrypted call.

### Advantages

The PC port and Video Capabilities are required for Cisco Unified Video Advantage to function correctly.

### Disadvantages

Enabling these features could possibly allow communication to the phone from the PC if ACLs are not used to protect the phone.

## Settings Access

Each Cisco Unified IP Phone has a network settings page that lists many of the network elements and detailed information that is needed for the phone to operate. This information could be used by an attacker to start a reconnaissance on the network with some of the information that is displayed on the phone's web page. For example, an attacker could look at the settings page to determine the default gateway, the TFTP server, and the Unified CM IP address. Each of these pieces of information could be used to gain access to the voice network or to attack a device in the voice network.

This access can be disabled on a phone-by-phone basis (see [Figure 19-5](#)) to prevent end users or attackers from obtaining the additional information such as Unified CM IP address and TFTP server information.

For more information on the phone settings page, refer to *Cisco Unified Communications Manager Administration Guide*, available at

[http://www.cisco.com/en/US/products/sw/voicesw/ps556/prod\\_maintenance\\_guides\\_list.html](http://www.cisco.com/en/US/products/sw/voicesw/ps556/prod_maintenance_guides_list.html)

**Figure 19-5 Phone Configuration Page in Unified CM**

Product Specific Configuration	
Disable Speakerphone	<input type="checkbox"/>
Disable Speakerphone and Headset	<input type="checkbox"/>
Forwarding Delay*	Disabled
PC Port*	Disabled
Settings Access*	Disabled
Gratuitous ARP*	Disabled
PC Voice VLAN Access*	Disabled
Video Capabilities*	Disabled
Auto Line Select*	Disabled
Web Access*	Disabled

**Advantages**

With access to the phone settings page disabled, end users and potential attackers are not able to see detailed information about the network and the IP Telephony information used by the voice system. With this feature disabled, some of the information that would be protected includes the IP address of the phone and the Unified CM to which the phone is registered.

**Disadvantages**

With access to the phone settings page disabled, end users lose the ability to change many of the settings on the phone that they would normally be able to control, such as speaker volume, contrast, and ring type. It might not be practical to use this security feature because of the limitations it places on end users with respect to the phone interface. However, access to the phone settings page does not have to be lost if the administrator chooses to restrict access rather than disable it.

## Phone Authentication and Encryption

Unified CM can be configured to provide multiple levels of security to the phones within a voice system, if those phones support those features. Depending on your security policy, phone placement, and phone support, the security can be configured to fit the needs of your company.

For information on which Cisco Unified IP Phone models support specific security features, refer to the documentation available at

[http://www.cisco.com/en/US/products/hw/phones/ps379/tsd\\_products\\_support\\_series\\_home.html](http://www.cisco.com/en/US/products/hw/phones/ps379/tsd_products_support_series_home.html)

To enable security on the phones and in the Unified CM cluster, refer to the *Cisco Unified Communications Manager Security Guide*, available at

[http://www.cisco.com/en/US/products/sw/voicesw/ps556/prod\\_maintenance\\_guides\\_list.html](http://www.cisco.com/en/US/products/sw/voicesw/ps556/prod_maintenance_guides_list.html)

### Advantages

When the security features are properly configured in Unified CM, all supported phones will have the following capabilities:

- Integrity — Does not allow TFTP file manipulation but does allow Transport Layer Security (TLS) signaling to the phones when enabled.
- Authentication — The image for the phone is authenticated from Unified CM to the phone, and the device (phone) is authenticated to Unified CM. All signaling messages between the phone and Unified CM are verified as being sent from the authorized device.
- Encryption — For supported devices, signaling and media can be encrypted to prevent eavesdropping.
- Secure Real-time Transport Protocol (SRTP) — Is supported to Cisco IOS MGCP gateways and, of course, phone-to-phone. Cisco Unity also supports SRTP for voicemail.

### Disadvantages

Unified CM supports authentication, integrity, and encryption for calls between two Cisco Unified IP Phones within a single cluster where no media services are used. However, Unified CM does not provide authentication, integrity, or encryption for all devices or phones. To determine if your device supports these features, refer to the documentation available at

[http://www.cisco.com/en/US/products/hw/phones/ps379/tsd\\_products\\_support\\_series\\_home.html](http://www.cisco.com/en/US/products/hw/phones/ps379/tsd_products_support_series_home.html)

In addition, auto-registration does not work if you configure the cluster for mixed mode, which is required for device authentication. You cannot implement signaling or media encryption if device authentication does not exist in the cluster – that is, if you do not install and configure the Cisco Certificate Trust List (CTL) client. Application Layer Gateways (ALGs) that allow IP Telephony traffic to traverse firewalls and Network Address Translation (NAT) also do not work with signaling encryption. Not all gateways, phones, or conference are supported with encrypted media.

## Access Security

This section covers security features at the Access level that can be used to protect the voice data within a network.

### Voice and Video VLANs

Before the phone has its IP address, the phone determines which VLAN it should be in by means of the Cisco Discovery Protocol (CDP) negotiation that takes place between the phone and the switch. This negotiation allows the phone to send packets with 802.1q tags to the switch in a "voice VLAN" so that the voice data and all other data coming from the PC behind the phone are separated from each other at Layer 2. Voice VLANs are not required for the phones to operate, but they provide additional separation from other data on the network.

Cisco Unified Video Advantage is a client application running on a PC, but it is also associated with an IP Phone. The PC will likely reside in the data VLAN while the phone will likely reside in the voice VLAN. To associate with the IP Phone, Cisco Unified Video Advantage uses the Cisco Audio Session Tunnel (CAST) protocol, which operates over TCP/IP. Therefore, Cisco Unified Video Advantage will have to communicate through whatever Layer 3 router is configured to route IP packets between the voice and data VLANs. If there are any access control lists or firewalls configured between those VLANs, they will have to be modified to permit the CAST protocol to operate. Fortunately, CAST uses TCP port 4224 in both directions, making this task easier. Cisco Unified Video Advantage

communicates with the IP Phone but not with Unified CM, except when Cisco Unified Video Advantage periodically checks with the TFTP server (which could be co-resident on one or more of the Unified CM servers) to download any software updates. Therefore, you must also permit the TFTP protocol between the data VLAN and the TFTP server(s).

Sony and Tandberg SCCP endpoints do not support Cisco Discovery Protocol (CDP) or 802.1Q VLAN ID tagging. Therefore, in a typical environment, these devices will reside in the data VLAN, unless the port has been configured manually to use the voice VLAN as the native VLAN. The Sony and Tandberg endpoints communicate with the TFTP server to download their configurations, with Unified CM for SCCP signaling, and with other endpoints for RTP audio/video media channels. Therefore, the TFTP protocol must be permitted between the data VLAN and the TFTP server(s), TCP port 2000 must be permitted between the data VLAN and the Unified CM server(s), and UDP ports for RTP media must be permitted between the data and voice VLANs.

H.323 clients, Multipoint Control Units (MCUs), and gateways communicate with Unified CM using the H.323 protocol. Unified CM H.323 trunks (such as H.225 and intercluster trunk variants as well as the RASAggregator trunk type) use a random port range rather than the well-known TCP port 1720. Therefore, you must permit a wide range of TCP ports between these devices and the Unified CM servers. MCUs and gateways are considered infrastructure devices, and they typically reside within the datacenter adjacent to the Unified CM servers. H.323 clients, on the other hand, typically reside in the data VLAN.

Cisco Unified Videoconferencing 3500 Series MCUs configured to run in SCCP mode communicate with the TFTP server(s) to download their configuration, with the Unified CM servers for signaling, and with other endpoints for RTP media traffic. Therefore, TFTP must be permitted between the MCU and the TFTP server(s), TCP port 2000 must be permitted between the MCUs and the Unified CM server(s), and UDP ports for RTP media must be permitted between the MCUs and the voice, data, and gateway VLANs.

### Advantages

Voice VLANs can be assigned automatically from the switch to the phone, thus allowing for Layer 2 and Layer 3 separations between voice data and all other data on a network. A voice VLAN also allows for a different IP addressing scheme because the separate VLAN can have a separate IP scope at the Dynamic Host Configuration Protocol (DHCP) server.

Applications use the CDP messaging from the phones to assist in locating phones during an emergency phone call. The location of the phone will be much more difficult to determine if CDP is not enabled on the access port to which that phone is attached.

### Disadvantages

There is a possibility that information could be gathered from the CDP messaging that would normally go to the phone, and that information could be used to discover some of the network. Not all devices that can be used for voice or video with Unified CM are able to use CDP to assist in discovering the voice VLAN.

## Switch Port

There are many security features within a Cisco switch infrastructure that can be used to secure a data network. This section describes some of the features that can be used in Cisco Access Switches to protect the IP Telephony data within a network. (See [Figure 19-6](#).) This section does not cover all of the security features available for all of the current Cisco switches, but it does list the most common security feature

used across many of the switches that Cisco manufactures. For additional information on the security features available on the particular Cisco gear deployed within your network, refer to the appropriate product documentation available at

<http://www.cisco.com>

**Figure 19-6** A Typical Access Layer Design to Which the Phones Attach

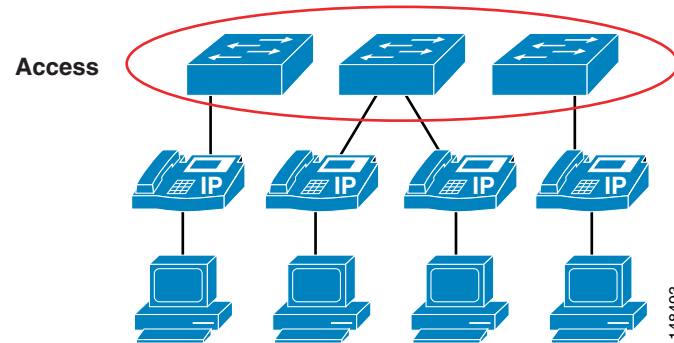

## Port Security: MAC CAM Flooding

A classic attack on a switched network is a MAC content-addressable memory (CAM) flooding attack. This type of attack floods the switch with so many MAC addresses that the switch does not know which port an end station or device is attached to. When the switch does not know which port a device is attached to, it broadcasts the traffic destined for that device to the entire VLAN. In this way, the attacker is able to see all traffic that is coming to all the users in a VLAN.

To disallow malicious MAC flooding attacks from hacker tools such as macof, limit the number of MAC addresses allowed to access individual ports based on the connectivity requirements for those ports. Malicious end-user stations can use macof to originate MAC flooding from random-source to random-destination MAC addresses, both directly connected to the switchport or through the IP phone. The macof tool is very aggressive and typically can fill a Cisco Catalyst switch content-addressable memory (CAM) table in less than ten seconds. The flooding of subsequent packets that remain unlearned because the CAM table is filled, is as disruptive and insecure as packets on a shared Ethernet hub for the VLAN that is being attacked.

Either port security or dynamic port security can be used to inhibit a MAC flooding attack. A customer with no requirement to use port security as an authorization mechanism would want to use dynamic port security with the number of MAC addresses appropriate to the function attached to a particular port. For example, a port with only a workstation attached to it would want to limit the number of learned MAC addresses to one. A port with a Cisco Unified IP Phone and a workstation behind it would want to set the number of learned MAC addresses to two (one for the IP phone itself and one for the workstation behind the phone) if a workstation is going to plug into the PC port on the phone. This setting in the past has been three MAC addresses, used with the older way of configuring the port in trunk mode. If you use the multi-VLAN access mode of configuration for the phone port, this setting will be two MAC addresses, one for the phone and one for the PC plugged into the phone. If there will be no workstation on the PC port, then the number of MAC addresses on that port should be set to one. These configurations are for a multi-VLAN access port on a switch. The configuration could be different if the port is set to trunk mode (not the recommended deployment of an access port with a phone and PC).

## Port Security: Prevent Port Access

Prevent all port access except from those devices designated by their MAC addresses to be on the port. This is a form of device-level security authorization. This requirement is used to authorize access to the network by using the single credential of the device's MAC address. By using port security (in its non-dynamic form), a network administrator would be required to associate MAC addresses statically for every port. However, with dynamic port security, network administrators can merely specify the number of MAC addresses they would like the switch to learn and, assuming the correct devices are the first devices to connect to the port, allow only those devices access to that port for some period of time.

The period of time can be determined by either a fixed timer or an inactivity timer (non-persistent access), or it can be permanently assigned. The feature to permanently assign a MAC address on a Cisco 6000 switch is called *autoconfigure*, and on the Cisco 4500, 2550, 2750, or 2950 switches the feature is called *sticky*. In both cases, the MAC address learned will remain on the port even in the event of a reload or reboot of the switch.

Persistent assignment of MAC addresses through *autoconfigure* or *sticky* can be cleared only by a command. The most common default behavior seen across the Cisco Catalyst switching platforms currently is the non-persistent behavior; the only behavior prior to Cisco CatOS Release 7.6(1) was persistent. No provision is made for device mobility by static port security or persistent dynamic port security. Although it is not the primary requirement, MAC flooding attacks are implicitly prevented by port security configurations that aim to limit access to certain MAC addresses.

From a security perspective, there are better mechanisms for both authenticating and authorizing port access based on userid and/or password credentials rather than using MAC address authorization. MAC addresses alone can easily be spoofed or falsified by most operating systems.

## Port Security: Prevent Rogue Network Extensions

Prevent rogue network extensions via hub or wireless access points (APs). Because it limits the number of MAC addresses to a port, port security can also be used as a mechanism to inhibit user extension to the IT-created network. For example, if a user plugs a wireless AP into a user-facing port or data port on a phone with port security defined for a single MAC address, the wireless AP itself would occupy that MAC address and not allow any devices behind it to access the network. (See Figure 19-7.) Generally, a configuration appropriate to stop MAC flooding is also appropriate to inhibit rogue access.

**Figure 19-7** Limited Number of MAC Addresses Prevents Rogue Network Extensions

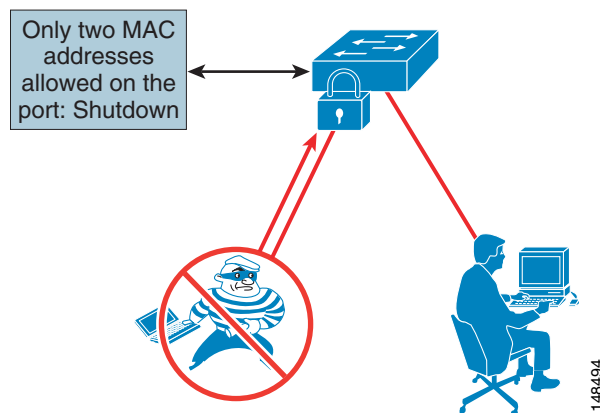

### Advantages

Port security prevents an attacker from flooding the CAM table of a switch and from turning any VLAN into a hub that transmits all received traffic to all ports. It also prevents unapproved extensions of the network by adding hubs or switches into the network.

### Disadvantages

If the number of MAC addresses is not defined correctly, there is a possibility of denying access to the network or error-disabling the port and removing all devices from the network.

### Configuration Example



**Note** This example configuration is based on a switch running correct code levels to support these features and not running trunk mode to the phone.

The following example illustrates the Cisco IOS commands to configure an access port with dynamic port security, running a phone with a device plugged into the data port on the phone:

```
switchport access vlan 10
switchport mode access
switchport voice vlan 20
switchport port-security
switchport port-security maximum 2
switchport port-security violation restrict
switchport port-security aging time 2
switchport port-security aging type inactivity
```



### Note

Phone firmware release (phone load) 8.3(3) enables Link Layer Discovery Protocol (LLDP) feature support. When combined with the use of the **switchport port-security maximum** command on a switch that does not recognize LLDP, the security violation condition might be triggered on the switchport. This situation can be avoided by setting the maximum allowed MAC addresses to accommodate LLDP. LLDP issues packets during the boot-up of the phone. Switches that do not support LLDP will consider the LLDP packets from the phone to be a separate unique MAC address that counts against the configured number of MAC addresses allowed. Switches that recognize LLDP do not count the LLDP traffic as a unique MAC address and would not have this issue. Check <http://www.cisco.com> for your combination of phone load and Cisco Unified Communications Manager and for information on LLDP support on your specific switch models and software versions.

The commands in the preceding example perform the following functions:

- **switchport port-security x/x enable**

This command enables the port security on the specified module/port.

- **switchport port-security violation restrict**

This command is the recommended configuration. The default is to disable the port. If you **restrict** the port, it will learn up to the maximum number of MAC addresses and then stop learning any new MAC addresses. If you have the port on the default setting of **disable** and the maximum number of MAC addresses is exceeded, the port will error-disable and turn off power to the phone. The default timer for the port to re-enable is 5 minutes. Depending on your security policy, it might be preferable to restrict the port and not shut down the phone by disabling the port.

- **switchport port-security aging time 2**

This command sets the amount of time that the MAC address will remain on the port without any traffic from that MAC address. Because of CDP communication between some switches and the phone, the recommended minimum time is 2 minutes.

- **switchport port-security aging type inactivity**

This command defines the type of aging that will be used on the port to time-out the learned MAC address.

## DHCP Snooping: Prevent Rogue DHCP Server Attacks

Dynamic Host Configuration Protocol (DHCP) Snooping prevents a non-approved DHCP or rogue DHCP server from handing out IP addresses on a network by blocking all replies to a DHCP request unless that port is allowed to reply. Because most phone deployments use DHCP to provide IP addresses to the phones, you should use the DHCP Snooping feature in the switches to secure DHCP messaging. Rogue DHCP servers can attempt to respond to the broadcast messages from a client to give out incorrect IP addresses, or they can attempt to confuse the client that is requesting an address.

When enabled, DHCP Snooping treats all ports in a VLAN as untrusted by default. An untrusted port is a user-facing port that should never make any reserved DHCP responses. If an untrusted DHCP-snooping port makes a DHCP server response, it will be blocked from responding. Therefore, rogue DHCP servers will be prevented from responding. However, legitimately attached DHCP servers or uplinks to legitimate servers must be trusted.

Figure 19-8 illustrates the normal operation of a network-attached device that requests an IP address from the DHCP server.

**Figure 19-8** Normal Operation of a DHCP Request

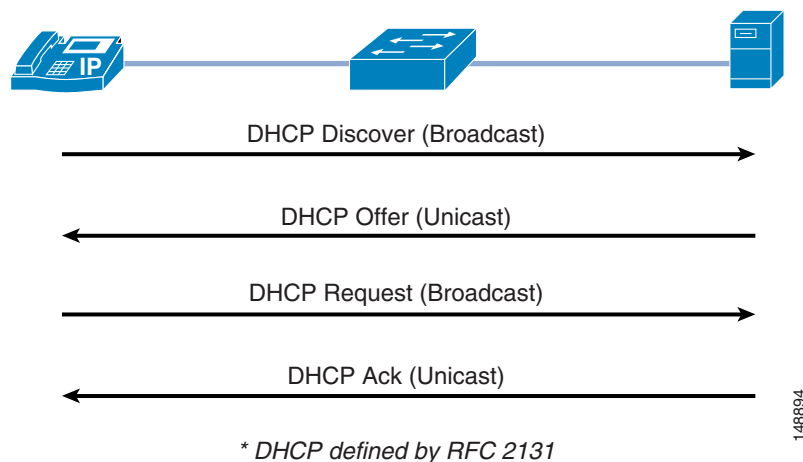

However, an attacker can request not just a single IP address but all of the IP addresses that are available within a VLAN. (See Figure 19-9.) This means that there would be no addresses for a legitimate device trying to get on the network, and without an IP address the phone cannot connect to Unified CM.

**Figure 19-9** An Attacker Can Take All Available IP Addresses on the VLAN

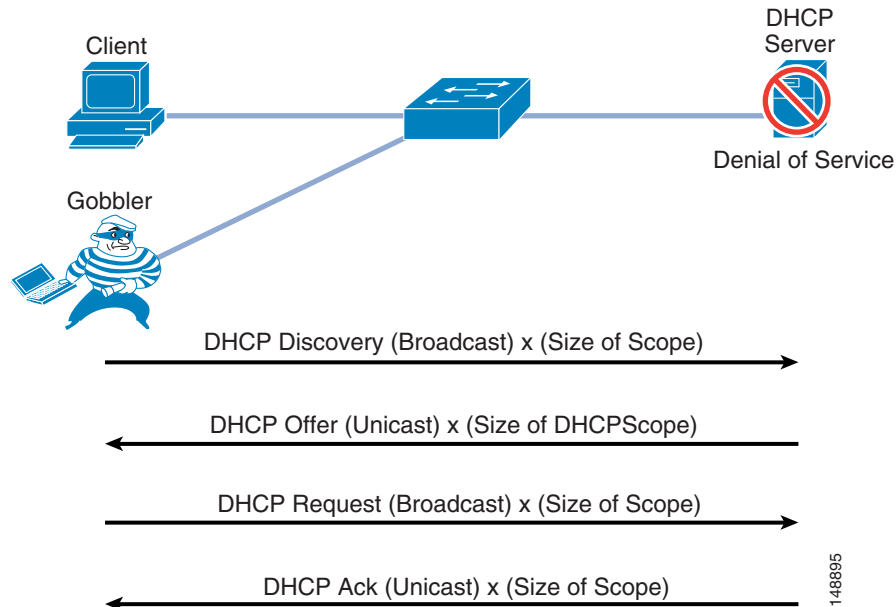

#### Advantaged

DHCP Snooping prevents unapproved DHCP servers from being on a network.

#### Disadvantages

Incorrect configurations of this feature can deny IP addresses to approved users.

## DHCP Snooping: Prevent DHCP Starvation Attacks

DHCP address scope starvation attacks from tools such as Gobbler are used to create a DHCP denial-of-service (DoS) attack. Because the Gobbler tool makes DHCP requests from different random source MAC addresses, you can prevent it from starving a DHCP address space by using port security to limit the number of MAC addresses. (See [Figure 19-10](#).) However, a more sophisticated DHCP starvation tool can make the DHCP requests from a single source MAC address and vary the DHCP payload information. With DHCP Snooping enabled, untrusted ports will make a comparison of the source MAC address to the DHCP payload information and fail the request if they do not match.

**Figure 19-10 Using DHCP Snooping to Prevent DHCP Starvation Attacks**

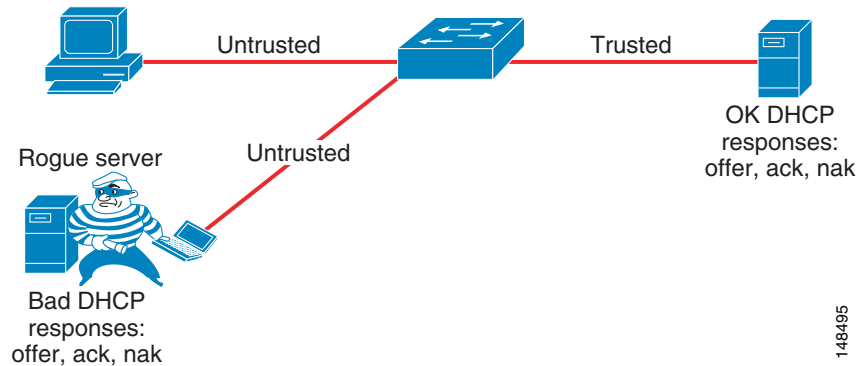

### Advantages

DHCP Snooping prevents any single device from capturing all the IP addresses in any given scope.

### Disadvantages

Incorrect configurations of this feature can deny IP addresses to approved users.

### Configuration Example

The following example illustrates the Cisco IOS commands to configure an access port with DHCP Snooping, running a phone with a device plugged into the data port on the phone:

- Global commands
 

```
ip dhcp snooping vlan 10, 20
no ip dhcp snooping information option
ip dhcp snooping
```
- Interface commands
 

```
no ip dhcp snooping trust (Default)
ip dhcp snooping limit rate 10 (pps)
ip dhcp snooping trust
```

The global commands in the preceding example perform the following functions:

- **ip dhcp snooping vlan 10, 20**  
This command specifies which VLANs have DHCP Snooping enabled.
- **No ip dhcp snooping information option**  
This command should be used so that Option 82 information is not required to lease a DHCP address. The Option 82 information must be supported by the DHCP server, but most enterprise servers do not support this feature. Option 82 is supported in Cisco IOS DHCP servers.
- **ip dhcp snooping**  
This command enables DHCP Snooping at the global level on the switches.

The interface commands in the preceding example perform the following functions:

- **no ip dhcp snooping trust**  
This command sets the interface to not trust any information coming into the port from a DHCP server.

- **ip dhcp snooping limit rate 10**

This command sets the default rate limit that is configured on the interface when DHCP Snooping is initially configured. This value can be changed depending on your security policy.

- **ip dhcp snooping trust**

You must use this command on the port through which DHCP information will be sent from a DHCP server. If you do not trust the port from which the DHCP information is coming, then none of the devices will ever receive a DHCP address. At least one port (access port or trunk port) with the DHCP server on it must be configured to allow this information to get to the clients. This command can also be used to trust any device connected to a port that has a static IP address and that will not use DHCP to get an IP address. Note that the uplink port to the DHCP server, or the trunk port to the DHCP server, will also have to be trusted.

## DHCP Snooping: Binding Information

Another function of DHCP Snooping is to record the DHCP binding information for untrusted ports that successfully get IP addresses from the DHCP servers. The binding information is recorded in a table on the Cisco Catalyst switch. The DHCP binding table contains the IP address, MAC address, lease length, port, and VLAN information for each binding entry. The binding information from DHCP Snooping remains in effect for the length of the DHCP binding period set by the DHCP server (that is, the DHCP lease time). The DHCP binding information is used to create dynamic entries for Dynamic ARP Inspection (DAI) to limit ARP responses for only those addresses that are DHCP-bound. The DHCP binding information is also used by the IP source guard to limit sourcing of IP packets to only those addresses that are DHCP-bound.

The following examples show binding information from DHCP Snooping.

- Displaying binding information for Cisco IOS:

```
show ip dhcp snooping binding
MacAddress      IpAddress      Lease(sec)      Type            VLAN  Interface
-----
00:03:47:B5:9F:AD  10.120.4.10    193185          dhcp-snooping   10    FastEthernet3/18
```

- Displaying binding information for Cisco CatOS:

```
ngcs-6500-1> (enable) show dhcp-snooping bindings
MacAddress      IpAddress      Lease(sec)      VLAN    Port
-----
00-10-a4-92-bf-dd  10.10.10.21    41303           10      2/5
```

There is a maximum limit to the number of binding table entries that each type of switch can store for DHCP Snooping. (Refer to the product documentation for your switch to determine this limit.) If you are concerned about the number of entries in your switch's binding table, you can reduce the lease time on the DHCP scope so that the entries in the binding table time-out sooner. The entries remain in the DHCP binding table until the lease runs out. In other words, the entries remain in the DHCP Snooping binding table as long as the DHCP server thinks the end station has that address. They are not removed from the port when the workstation or phone is unplugged.

If you have a Cisco Unified IP Phone plugged into a port and then move it to a different port, you might have two entries in the DHCP binding table with the same MAC and IP address on different ports. This behavior is considered normal operation.

## Requirement for Dynamic ARP Inspection

Dynamic Address Resolution Protocol (ARP) Inspection (DAI) is a feature used on the switch to prevent Gratuitous ARP attacks on the devices plugged into the switch and on the router. Although it is similar to the Gratuitous ARP feature mentioned previously for the phones, Dynamic ARP protects all the devices on the LAN, and it is not just a phone feature.

In its most basic function, Address Resolution Protocol (ARP) enables a station to bind a MAC address to an IP address in an ARP cache, so that the two stations can communicate on a LAN segment. A station sends out an ARP request as a MAC broadcast. The station that owns the IP address in that request will give an ARP response (with its IP and MAC address) to the requesting station. The requesting station will cache the response in its ARP cache, which has a limited lifetime. The default ARP cache lifetime for Microsoft Windows is 2 minutes; for Linux, the default lifetime is 30 seconds; and for Cisco IP phones, the default lifetime is 40 minutes.

ARP also makes the provision for a function called Gratuitous ARP. Gratuitous ARP (GARP) is an unsolicited ARP reply. In its normal usage, it is sent as a MAC broadcast. All stations on a LAN segment that receive a GARP message will cache this unsolicited ARP reply, which acknowledges the sender as the owner of the IP address contained in the GARP message. Gratuitous ARP has a legitimate use for a station that needs to take over an address for another station on failure.

However, Gratuitous ARP can also be exploited by malicious programs that want to illegitimately take on the identity of another station. When a malicious station redirects traffic to itself from two other stations that were talking to each other, the hacker who sent the GARP messages becomes the man-in-the-middle. Hacker programs such as ettercap do this with precision by issuing "private" GARP messages to specific MAC addresses rather than broadcasting them. In this way, the victim of the attack does not see the GARP packet for its own address. Ettercap also keeps its ARP poisoning in effect by repeatedly sending the private GARP messages every 30 seconds.

Dynamic ARP Inspection (DAI) is used to inspect all ARP requests and replies (gratuitous or non-gratuitous) coming from untrusted (or user-facing) ports to ensure that they belong to the ARP owner. The ARP owner is the port that has a DHCP binding which matches the IP address contained in the ARP reply. ARP packets from a DAI trusted port are not inspected and are bridged to their respective VLANs.

### Using DAI

Dynamic ARP Inspection (DAI) requires that a DHCP binding be present to legitimize ARP responses or Gratuitous ARP messages. If a host does not use DHCP to obtain its address, it must either be trusted or an ARP inspection access control list (ACL) must be created to map the host's IP and MAC address. (See [Figure 19-11](#).) Like DHCP Snooping, DAI is enabled per VLAN, with all ports defined as untrusted by default. To leverage the binding information from DHCP Snooping, DAI requires that DHCP Snooping be enabled on the VLAN prior to enabling DAI. If DHCP Snooping is not enabled before you enable DAI, none of the devices in that VLAN will be able to use ARP to connect to any other device in their VLAN, including the default gateway. The result will be a self-imposed denial of service to any device in that VLAN.

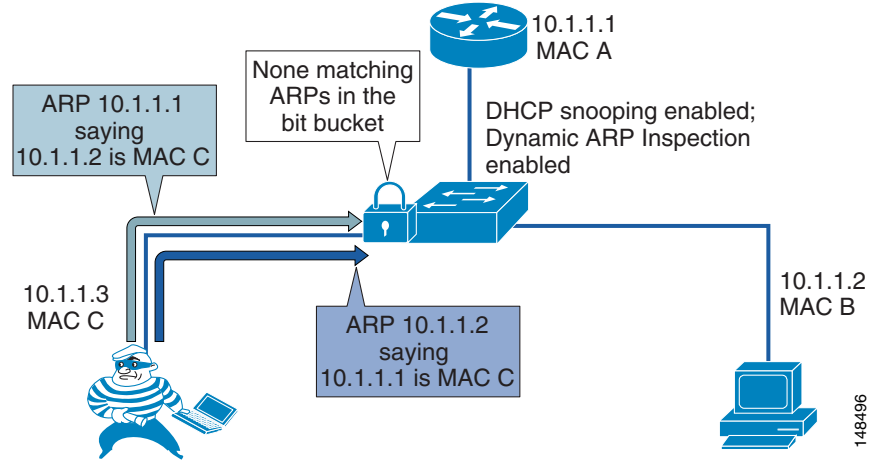
**Figure 19-11 Using DHCP Snooping and DAI to Block ARP Attacks**

Because of the importance of the DHCP Snooping binding table to the use of DAI, it is important to back up the binding table. The DHCP Snooping binding table can be backed up to bootflash, File Transfer Protocol (FTP), Remote Copy Protocol (RCP), slot0, and Trivial File Transfer Protocol (TFTP). If the DHCP Snooping binding table is not backed up, the Cisco Unified IP Phones could lose contact with the default gateway during a switch reboot. For example, assume that the DHCP Snooping binding table is not backed up and that you are using Cisco Unified IP Phones with a power adapter instead of line power. When the switch comes back up after a reboot, there will be no DHCP Snooping binding table entry for the phone, and the phone will not be able to communicate with the default gateway unless the DHCP Snooping binding table is backed up and loads the old information before traffic starts to flow from the phone.

### Advantages

DAI prevents an attacker from running ARP-based attacks in a network to disrupt or sniff the traffic between people who are adjacent to the attacker at Layer 2.

### Disadvantages

Incorrect configurations of this feature can deny network access to approved users. If a device has no entry in the DHCP Snooping binding table, then that device will not be able to use ARP to connect to the default gateway and therefore will not be able to send traffic. If you use static IP addresses, those addresses will have to be entered manually into the DHCP Snooping binding table. If you have devices that do not use DHCP again to obtain their IP addresses when a link goes down (some UNIX or Linux machines behave this way), then you must back up the DHCP Snooping binding table.

### Configuration Example

The following example illustrates the Cisco IOS commands to configure access ports with DHCP Snooping and Dynamic ARP Inspection:

- Global commands

```
ip dhcp snooping vlan 10,20 (required)
no ip dhcp snooping information option (required without option 82 dhcp server)
ip dhcp snooping (required)
ip arp inspection vlan 10,20
ip dhcp snooping database tftp://172.26.168.10/tftpboot/cisco/ngcs-dhcpdb
```

- Interface commands

```
ip dhcp snooping trust
ip arp inspection trust
no ip arp inspection trust (default)
ip arp inspection limit rate 15 (pps)
```

The global commands in the preceding example perform the following functions:

- **ip arp inspection vlan 10,20**

This command specifies which VLANs have Dynamic ARP Inspection (DAI) enabled.

- **ip arp inspection trust**

As with **ip dhcp snooping trust**, this command allows a trusted device such as a router to reply to ARP messages. This command must be configured on the port for your router, otherwise the router will not be able to respond to any ARP requests because the router will not be in the DHCP Snooping binding table.

- **no ip arp inspection trust**

This is the default setting for every port in the VLAN. Trust must be enabled.

- **ip arp inspection limit rate 15 (pps)**

This command sets the global default value for the maximum number of packets per second (pps) that are allow for ARP messages on the interfaces. If this value is exceeded, then the interface will be disabled. If this behavior is a concern, you can increase or decrease the limit or set it to **none**.

- **ip dhcp snooping database tftp://172.26.168.10/tftpboot/cisco/ngcs-dhcpdb**

This command backs up the DHCP Snooping binding table to the TFTP server. The DHCP Snooping binding table can be backed up to bootflash, FTP, RCP, slot0, and TFTP.

The interface commands in the preceding example perform the following functions:

- **no ip arp inspection trust**

This command enables DAI on the port and checks all ARPs against the DHCP Snooping binding table.

- **ip arp inspection limit rate 15 (pps)**

This command specifies the maximum number of packets per second (pps) that are allow for ARP messages on the interface. If the interface sees more than the specified number of ARP messages in a second, it will disable the port. Depending on your security policy, the default value (15 pps) might be the preferred setting. If you do not want to disable the phone when the port receives more than 15 ARP messages in a second, you can set the rate limit to **none**, which will allow the phone to stay up.

## IP Source Guard

Beyond ARP spoofing, an attacker can also do IP address spoofing. This method is commonly use to perform DoS attacks on a second party by sending packets through a third party, thus masking the identity of the attacking system. A simple example of this occurs when an attacker pings a third-party system while sourcing the IP address of the second party that is being attacked. The ping response will be directed to the second party from the third-party system. Aggressive SYN-flooding originating from spoofed IP addresses is another common type of attack used to overwhelm a server with TCP half-sessions.

The IP Source Guard (IPSG) feature, when invoked, dynamically creates an ACL based on the contents of the DHCP Snooping binding table. This ACL ensures that traffic is sourced from the IP address issued at DHCP binding time and prevents any traffic from being forwarded by other spoofed addresses. While

DHCP Snooping is a prerequisite for IP Source Guard, DAI is not. However, Cisco recommend that you enable DAI in addition to IP Source Guard to prevent ARP-poisoning man-in-the-middle attacks in addition to IP address spoofing. (See [Figure 19-12](#).)

**Figure 19-12** Using IP Source Guard to Prevent Address Spoofing

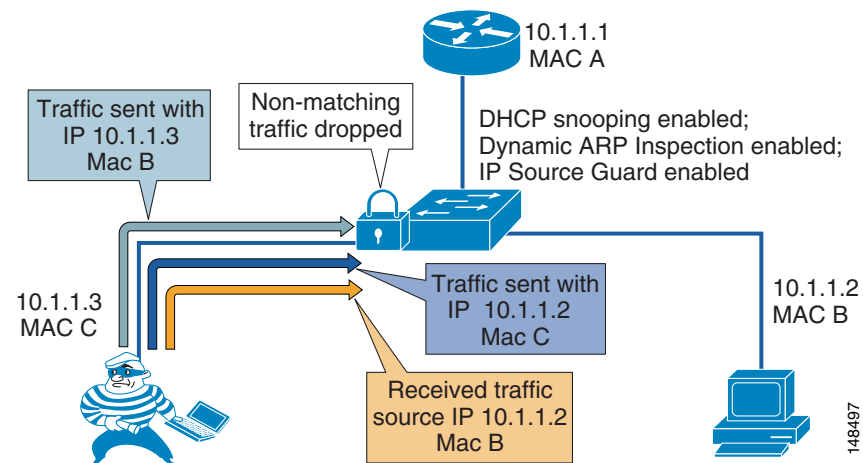

With IP address spoofing, an attacker can impersonate a valid address either by manually changing an address or by running a program design to do address spoofing, such as hping2. Internet worms can use spoofing techniques to disguise their origins.

### Configuration Example

The following example illustrates the Cisco IOS commands to configure access ports with IP Source Guard:

- Commands that must be enabled before you enable IP Source Guard

```
ip dhcp snooping vlan 4,104
no ip dhcp snooping information option
ip dhcp snooping
```

- Interface command — This command enables the IP Source Guard without DHCP Option 82.

```
ip verify source vlan dhcp-snooping
```

### Additional Information

For additional information on network security, refer to the Cisco documentation at the following locations:

- [http://www.cisco.com/en/US/products/hw/switches/ps708/products\\_white\\_paper0900aecd8015f0ae.shtml](http://www.cisco.com/en/US/products/hw/switches/ps708/products_white_paper0900aecd8015f0ae.shtml)
- [http://www.cisco.com/en/US/prod/collateral/wireless/wirelssw/ps1953/product\\_implementation\\_design\\_guide09186a00800a3016.pdf](http://www.cisco.com/en/US/prod/collateral/wireless/wirelssw/ps1953/product_implementation_design_guide09186a00800a3016.pdf)

## Quality of Service

Quality of Service (QoS) is a vital part of any security policy for an enterprise network. Even though most people think of QoS as setting the priority of traffic in a network, it also controls the amount of data that is allowed into the network. In the case of Cisco switches, that control point is at the port level when the data comes from the phone to the Ethernet switch. The more control applied at the edge of the network at the access port, the fewer problems will be encountered as the data aggregates in the network.

As mentioned previously in the lobby phone example, you can provide enough flow control of the traffic at the access port level to prevent any attacker from launching a denial-of-service (DoS) attack from that port in the lobby. The configuration for that example was not as aggressive as it could be because the QoS configuration allowed traffic sent to the port to exceed the maximum rate, but the traffic was remarked to the level of scavenger class. Given a more aggressive QoS policy, any amount of traffic that exceeded that maximum limit of the policy could just be dropped at the port, and that "unknown" traffic would never make it into the network. QoS should be enabled across the entire network to give the IP Telephony data high priority from end to end.

For more information on QoS, refer to the chapter on [Network Infrastructure, page 3-1](#), and the *Enterprise QoS Solution Reference Network Design (SRND) Guide* available at

<http://www.cisco.com/go/designzone>

### Advantages

QoS can be used to control not only the priority of the traffic in the network but also the amount of traffic that can travel through any specific interface. Cisco Smartports templates have been created to assist in deploying voice QoS in a network at the access port level.

### Disadvantages

If QoS settings are outside the standard Cisco Smartports template, the configuration can be complex and difficult to manage in large IP Telephony deployments.

## Access Control Lists

This section covers access control lists (ACLs) and their uses in protecting voice data.

## VLAN Access Control Lists

You can use VLAN access control lists (ACLs) to control data that flows on a network. Cisco switches have the capability of controlling Layers 2 to 4 within a VLAN ACL. Depending on the types of switches in a network, VLAN ACLs can be used to block traffic into and out of a particular VLAN. They can also be used to block intra-VLAN traffic to control what happens inside the VLAN between devices.

If you plan to deploy a VLAN ACL, you should verify which ports are needed to allow the phones to function with each application used in your IP Telephony network. Normally any VLAN ACL would be applied to the VLAN that the phones use. This would allow control at the access port, as close as possible to the devices that are plugged into that access port.

Refer to the following product documentation for information on configuring VLAN ACLs:

- Cisco Catalyst 3750 Switches

[http://www.cisco.com/en/US/products/hw/switches/ps5023/products\\_installation\\_and\\_configuration\\_guides\\_list.html](http://www.cisco.com/en/US/products/hw/switches/ps5023/products_installation_and_configuration_guides_list.html)

- Cisco Catalyst 4500 Series Switches  
[http://www.cisco.com/en/US/products/hw/switches/ps4324/products\\_installation\\_and\\_configuration\\_guides\\_list.html](http://www.cisco.com/en/US/products/hw/switches/ps4324/products_installation_and_configuration_guides_list.html)
- Cisco Catalyst 6500 Series Switches  
[http://www.cisco.com/en/US/products/hw/switches/ps708/products\\_installation\\_and\\_configuration\\_guides\\_list.html](http://www.cisco.com/en/US/products/hw/switches/ps708/products_installation_and_configuration_guides_list.html)

The following example represents a VLAN ACL that allows only the traffic for a Cisco 7960 IP Phone to boot and function in a VLAN. (Inline comments indicate the purpose of each line of the ACL.) This example VLAN ACL is for the ports used with Cisco Unified CM Release 4.1. The example uses the following IP address ranges:

- Phones are in the range 10.0.20.\*
- Servers are in the range 10.0.10.\*
- Gateways are in the range 10.0.30.\*
- Default gateways are 10.0.10.2 and 10.0.10.3
- DNS server IP address is 10.0.40.3

**Note**

The ports do change when either the application is updated or the OS is updated, or both. This note applies to all the IP Telephony devices in the network, including phones. To obtain the latest list of ports used by a product, refer to the appropriate documentation for the version of the product that is running on your network. The *Cisco Unified Communications Manager TCP and UDP Port Usage* guide is available at

[http://www.cisco.com/en/US/products/sw/voicesw/ps556/prod\\_maintenance\\_guides\\_list.html](http://www.cisco.com/en/US/products/sw/voicesw/ps556/prod_maintenance_guides_list.html).

```

20 permit udp host 10.0.10.2 eq 1985 any
30 permit udp host 10.0.10.3 eq 1985 any
!permit HSRP from the routers
40 permit udp any any eq bootpc
50 permit udp any any eq bootps
!permit DHCP activity
60 permit udp 10.0.10.0 0.0.0.255 range 32768 61000 10.0.20.0 0.0.0.255 eq tftp
70 permit udp 10.0.20.0 0.0.0.255 range 1024 5000 10.0.10.0 0.0.0.255 range 32768 61000
80 permit udp 10.0.10.0 0.0.0.255 range 32768 61000 10.0.20.0 0.0.0.255 range 1024 5000
!permit the tftp traffic from the tftp server and phone
90 permit udp 10.0.10.0 0.0.0.255 range 32768 61000 host 10.0.40.3 eq domain
100 permit udp host 172.19.244.2 eq domain 10.0.10.0 0.0.0.255 range 32768 61000
!permit DNS to and from the phone
110 permit tcp 10.0.10.0 0.0.0.255 range 32768 61000 10.0.20.0 0.0.0.255 eq 2000
120 permit tcp 10.0.20.0 0.0.0.255 eq 2000 10.0.10.0 0.0.0.255 range 32768 61000
!permit signaling to and from the phone.
130 permit udp 10.0.10.0 0.0.0.255 range 16384 32767 10.0.10.0 0.0.0.255 range 16384 32767
140 permit udp 10.0.0.0 0.0.255.255 range 16384 32767 10.0.10.0 0.0.0.255 range 16384
32767
150 permit udp 10.0.10.0 0.0.0.255 range 16384 32767 10.0.0.0 0.0.255.255 range 16384
43767
!permit all phones to send udp to each other
160 permit tcp 10.0.10.0 0.0.0.255 range 32768 61000 10.0.20.0 0.0.0.255 eq www
170 permit tcp 10.0.20.0 0.0.0.255 eq www 10.0.10.0 0.0.0.255 range 32768 61000
180 permit tcp 10.0.20.0 0.0.0.255 range 32768 61000 10.0.10.0 0.0.0.255 eq www
190 permit tcp 10.0.10.0 0.0.0.255 eq www 10.0.20.0 0.0.0.255 range 32768 61000
!permit web access to and from the phone
200 permit Intelligent Contact ManagementP any any
!allow all icmp - phone to phone, gateway to phone, and NMS to phone

```

```
220 permit udp 10.0.30.0 0.0.0.255 rang 16384 327676 10.0.10.0 0.0.0.255 rang 16384 32767
!permit udp to the gateways in the network for pstn access
```

As this example ACL illustrates, the more well-defined the IP addresses are in a network, the easier it is to write and deploy an ACL.

For more details on how to apply VLAN ACLs, refer to the following documentation:

- Cisco Catalyst 3750 Switches  
[http://www.cisco.com/en/US/products/hw/switches/ps5023/products\\_installation\\_and\\_configuration\\_guides\\_list.html](http://www.cisco.com/en/US/products/hw/switches/ps5023/products_installation_and_configuration_guides_list.html)
- Cisco Catalyst 4500 Series Switches  
[http://www.cisco.com/en/US/products/hw/switches/ps4324/products\\_installation\\_and\\_configuration\\_guides\\_list.html](http://www.cisco.com/en/US/products/hw/switches/ps4324/products_installation_and_configuration_guides_list.html)
- Cisco Catalyst 6500 Series Switches  
[http://www.cisco.com/en/US/products/hw/switches/ps708/products\\_installation\\_and\\_configuration\\_guides\\_list.html](http://www.cisco.com/en/US/products/hw/switches/ps708/products_installation_and_configuration_guides_list.html)

#### Advantages

ACLs provide the ability to control the network traffic in and out of a VLAN as well as the ability to control the traffic within the VLAN.

#### Disadvantages

VLAN ACLs are very difficult to deploy and manage at an access-port level that is highly mobile. Because of these management issues, care should be taken when deploying VLAN ACLs at the access port in the network.

## Router Access Control Lists

As with VLAN ACLs, routers have the ability to process both inbound and outbound ACLs by port. The first Layer 3 device is the demarcation point between voice data and other types of data when using voice and data VLANs, where the two types of data are allowed to send traffic to each other. Unlike the VLAN ACLs, router ACLs are not deployed in every access device in your network. Rather, they are applied at the edge router, where all data is prepared for routing across the network. This is the perfect location to apply a Layer 3 ACL to control which areas the devices in each of the VLANs have the ability to access within a network. Layer 3 ACLs can be deployed across your entire network to protect devices from each other at points where the traffic converges. (See [Figure 19-13](#).)

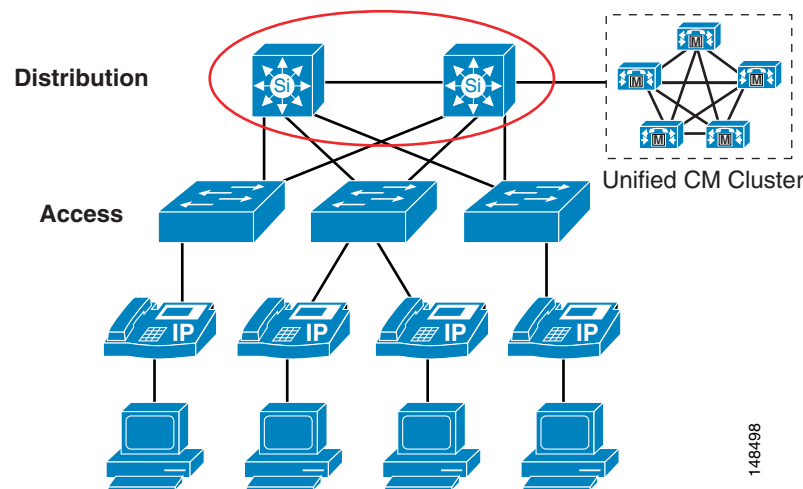
**Figure 19-13 Router ACLs at Layer 3**

There are many types of ACLs that can be deployed at Layer 3. For descriptions and examples of the most common types, refer to *Configuring Commonly Used IP ACLs*, available (with Cisco partner login required) at

[http://cisco.com/en/US/partner/tech/tk648/tk361/technologies\\_configuration\\_example09186a0080100548.shtml](http://cisco.com/en/US/partner/tech/tk648/tk361/technologies_configuration_example09186a0080100548.shtml)

Depending on your security policy, the Layer 3 ACLs can be as simple as not allowing IP traffic from the non-voice VLANs to access the voice gateway in the network, or the ACLs can be detailed enough to control the individual ports and the time of the day that are used by other devices to communicate to IP Telephony devices. Assuming that there are no software phones, ACLs can be written to block all traffic (by IP address or IP range) to Unified CMs, voice gateways, phones, and any other voice application that is being used for voice-only services. This method simplifies the ACLs at Layer 3 compared to the ACLs at Layer 2 or VLAN ACLs.

This example uses the following IP address ranges:

- Phones are in the range 10.0.20.\*
- IP Telephony servers are in the range 10.0.10.\*
- Gateways are in the range 10.0.30.\*
- All other devices in the network are in the range 192.168.\*.\*

```
10 deny ip 192.168.0.0 0.0.255.255 10.0.10.0 0.0.0.255
!deny all non voice devices to the voip servers
20 deny 192.168.0.0 0.0.255.255 10.0.30.0 0.0.0.255
!deny all non voice devices to the voip gateways
30 deny 192.168.0.0 0.0.255.255 10.0.20.0 0.0.0.255
!deny all non voice devices to communicate with the phones ip addresses
```

### Advantages

ACLs are much easier to manage and deploy at Layer 3. Layer 3 is one of the first opportunities to apply control to voice data and other non-voice data in the network.

**Disadvantages**

As the ACLs become more granular and detailed, any changes in port usage in a network could break not only voice but also other applications in the network.

If there are software phones in the network, if web access to the phone is allowed, or if you use the Attendant Console or other applications that need access to the voice VLAN subnets, the ACLs are much more difficult to deploy and control.

## Gateways and Media Resources

Gateways and media resources are devices that convert an IP Telephony call into a PSTN call. When an outside call is placed, the gateway or media resource is one of the few places within an IP Telephony network to which all the voice RTP streams flow.

Because IP Telephony gateways and media resources can be placed almost anywhere in a network, securing an IP Telephony gateway or media resource might be considered more difficult than securing other devices, depending on your security policy. However, depending on which point trust is established in the network, the gateways and media resources can be quite easy to secure. Because of the way the gateways and media resources are controlled by Unified CM, if the path that the signaling takes to the gateway or media resource is in what is considered a secure section of the network, a simple ACL can be used to control signaling to and from the gateway or media resource. If the network is not considered secure between the gateways (or media resources) and where the Unified CMs are located (such as when a gateway is located at a remote branch), the infrastructure can be used to build IPsec tunnels to the gateways and media resources to protect the signaling. In most networks there would most likely be a combination of the two approaches (ACL and IPsec) to secure those devices.

For H.323 videoconferencing devices, an ACL can be written to block port 1720 for H.225 trunks from any H.323 client in the network. This method would block users from initiating an H.225 session with each other directly. Cisco devices might use different ports for H.225, so refer to the product documentation for your equipment to see which port is used. If possible, change the port to 1720 so that only one ACL is needed to control signaling.

Because we use QoS at the edge of the network, if an attacker can get into the voice VLAN and determine where the gateways and media resources are, QoS at the port would limit how much data the attacker would be able to send to the gateway or media resource. (See [Figure 19-14](#).)

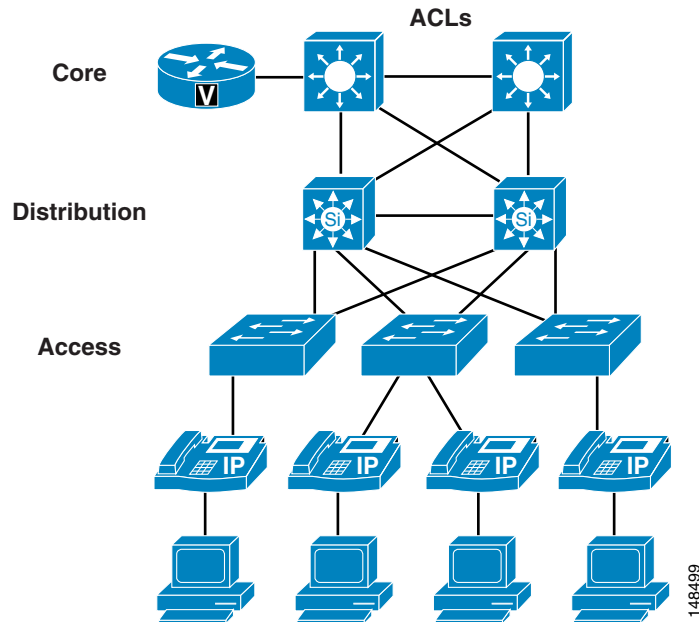
**Figure 19-14** Securing Gateways and Media Resources with IPSec, ACLs, and QoS

Some gateways and media resources support Secure RTP (SRTP) to the gateways and media resources from the phones, if the phone is enabled for SRTP. To determine if a gateway or media resource supports SRTP, refer to the appropriate product documentation at

<http://www.cisco.com>

For more information on IPSec tunnels, refer to the *Site-to-Site IPSec VPN Solution Reference Network Design (SRND)*, available at

<http://www.cisco.com/go/designzone>

## Putting Firewalls Around Gateways

Some very interesting issues arise from placing firewalls between a phone making a call and the gateway to the PSTN network. Stateful firewalls look into the signaling messages between Unified CM, the gateway, and the phone, and they open up a pinhole for the RTP streams to allow the call to take place. To do the same thing with a normal ACL, the entire port ranges used by the RTP streams would have to be open to the gateway.

There are two ways to deploy gateways within a network: behind a firewall and in front of a firewall. If you place the gateway behind a firewall, all the media from the phones that are using that gateway have to flow through the firewall, and additional CPU resources are required to run those streams through the firewall. In turn, the firewall adds control of those streams and protects the gateway from denial-of-service attacks. (See [Figure 19-15](#).)

Figure 19-15 Gateway Placed Behind a Firewall

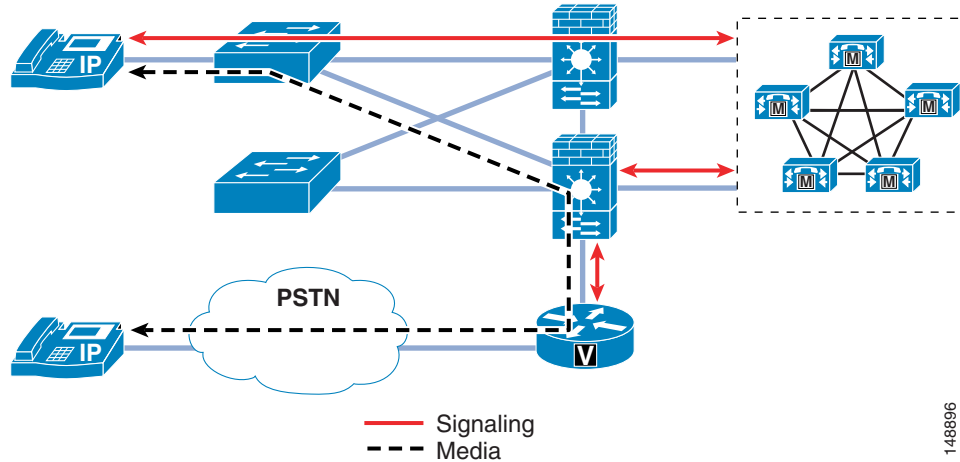

The second way to deploy the gateway is outside the firewall. Because the only type of data that is ever sent to the gateway from the phones is RTP streams, the access switch's QoS features control the amount of RTP traffic that can be sent to that gateway. The only thing that Unified CM sends to the gateway is the signaling to set up the call. If the gateway is put in an area of the network that is trusted, the only communication that has to be allowed between Unified CM and the gateway is that signaling. (See [Figure 19-15](#).) This method of deployment decreases the load on the firewall because the RTP streams are not going through the firewall.

#### Advantages

Unlike an ACL, most firewall configurations will open only the RTP stream port that Unified CM has told the phone and the gateway to use between those two devices as long as the signaling goes through the firewall. The firewall also has additional features for DoS attacks and Cisco Intrusion Detection System (IDS) signatures to look at interesting traffic and determine if any attackers are doing something they should not be doing.

#### Disadvantages

As stated in the section on [Firewalls](#), [page 19-31](#), when a firewall is looking at all the signaling and RTP streams from phones to a gateway, capacity could be an issue. Also, if data other than voice data is running through the firewall, CPU usage must be monitored to make sure that the firewall does not affect the calls that are running through the firewall.

## Firewalls and H.323

H.323 utilizes H.245 for setting up the media streams between endpoints, and for the duration of that call the H.245 session remains active between Unified CM and the H.323 gateway. Subsequent changes to the call flow are done via H.245.

By default, a Cisco firewall tracks the H.245 session and the associated RTP streams of calls, and it will time-out the H.245 session if no RTP traffic crosses the firewall for longer than 5 minutes. For topologies where at least one H.323 gateway and the other endpoints are all on one side of the firewall, the firewall will not see the RTP traffic. After 5 minutes, the H.245 session will be blocked by the firewall, which stops control of that stream but does not affect the stream itself. For example, no supplementary services will be available.

To make this topology function, you may change the default behavior of the firewall by using the command **timeout h323** [*hr:min:sec*] to set the value high enough so that the maximum anticipated call duration is specified. For example, you might want to increase the duration for a mobile agent for whom a permanent call is set up first thing in the morning and exists for the agent's entire shift. In that case, the duration would be set to a value longer than the agent's shift.

#### Advantages

The advantage of the configuration change from default is that it allows H.323 to not lose any call functionality when all endpoints are on the same side of the firewall.

#### Disadvantages

The timeout feature increases protection of the call agents that are behind the firewall, but increasing the timeout reduces that value of the feature.

## Firewalls

Firewalls can be used in conjunction with ACLs to protect the voice servers and the voice gateways from devices that are not allowed to communicate with IP Telephony devices. Because of the dynamic nature of the ports used by IP Telephony, having a firewall does help to control opening up a large range of ports needed for IP Telephony communications. Given the complexities that firewalls introduce into a network design, you must take care in placing and configuring the firewalls and the devices around the firewalls to allow the traffic that is considered correct to pass while blocking the traffic that needs to be blocked.

IP Telephony networks have unique data flows. The phones use a client/server model for signaling for call setup, and Unified CM controls the phones through that signaling. The data flows for the IP Telephony RTP streams are more like a peer-to-peer network, and the phones or gateways talk directly to each other via the RTP streams. If the signaling flows do not go through the firewall so that the firewall can inspect the signaling traffic, the RTP streams could be blocked because the firewall will not know which ports need to be opened to allow the RTP streams for a conversation.

A firewall placed in a correctly designed network can force all the data through that device, so capacities and performance need to be taken into account. Performance includes the amount of latency, which can be increased by a firewall if the firewall is under high load or even under attack. The general rule in an IP Telephony deployment is to keep the CPU usage of an FWSM, ASA, or PIX to less than 60% for normal usage. If the CPU runs over 60%, it increases the chance of impacting IP phones, call setup, and registration. If the CPU usage stays at a sustained level above 60%, the registered IP phones will be affected, quality of calls in progress will degrade, and call setup for new calls will suffer. In the worst case, if the sustained CPU usage stays above 60%, phones will start to un-register. When this happens, they will attempt to re-register with Unified CM, thus increasing the load on the firewalls even more. If this were to happen, the effect would be a rolling blackout of phones un-registering and attempting to re-register with Unified CM. Until the CPU usage of the firewall decreases to under 60% sustained load, this rolling blackout would continue and most (if not all) of the phones would be affected. If you are currently using a Cisco firewall in your network, you should monitor the CPU usage carefully when adding IP Telephony traffic to your network so that you do not adversely affect that traffic.

There are many ways to deploy firewalls. This section concentrates on the ASA, PIX, and FWSM in the active/standby mode in both routed and transparent scenarios. Each of the configurations in this section is in single-context mode within the voice sections of the firewall configurations.

All of the Cisco firewalls can run in either multiple-context or single-context mode. In single-context mode, the firewall is a single firewall that controls all traffic flowing through it. In multiple-context mode, the firewalls can be turned into many virtual firewalls. Each of these contexts or virtual firewalls have their own configurations and can be controlled by different groups or administrators. Each time a

new context is added to a firewall, it will increase the load and memory requirements on that firewall. When you deploy a new context, make sure that the CPU requirements are met so that voice RTP streams are not adversely affected.

### Functionality Differences of the ASA or PIX and the FWSM

Figure 19-16 shows a logical representation of redundant firewalls in a network. Placement is the same for both routed configurations and transparent configurations.

**Figure 19-16 Redundant Routed or Transparent Firewalls**

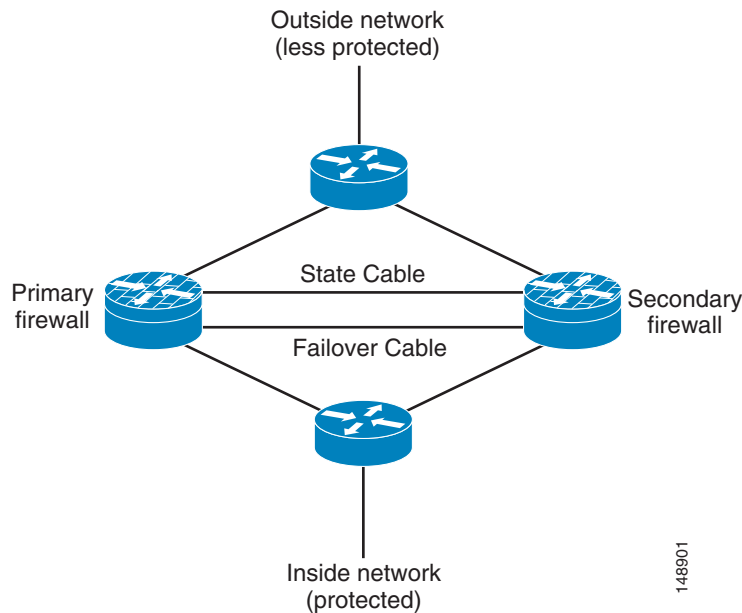

Both the Cisco Adaptive Security Appliance (ASA) and the Cisco Private Internet Exchange (PIX) operate in a different manner than the Cisco Firewall Services Modules (FWSM). Within an ASA or PIX, as long as there are no ACLs on a more trusted interface, all traffic from that interface is trusted and allowed out to a less-trusted interface. (See Figure 19-17.) For example, all traffic from the inside or data center interface of an ASA will be allowed to go out to the outside interface of the ASA. Once any ACL is applied to the more trusted interface on a ASA/PIX, all other traffic is denied (DENY) and the firewall will then function very much like the FWSM. (See Figure 19-18.)

**Figure 19-17 Functionality of a Cisco ASA or PIX**

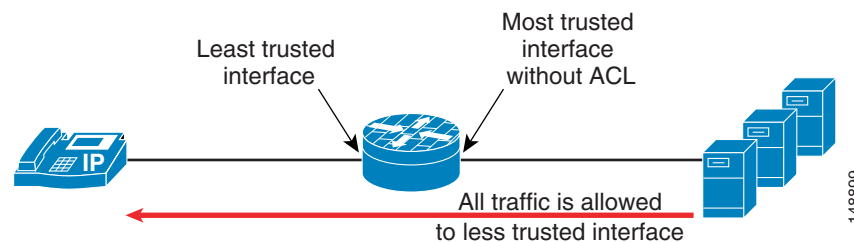

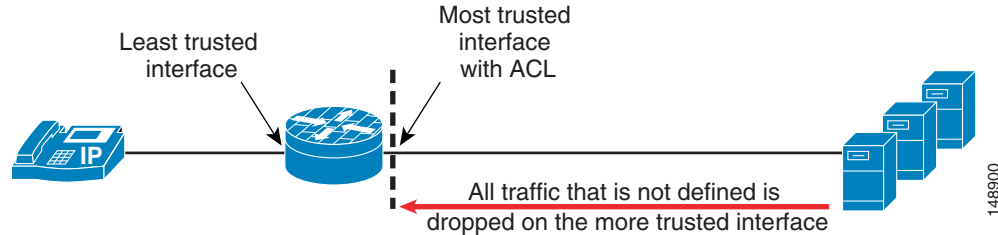
**Figure 19-18** *Functionality of a Cisco FWSM***Overall Advantages of Firewalls**

A firewall provides a security control point in the network for applications that run over the network. A firewall also provides dynamic opening of ports for IP Telephony conversations if that traffic is running through the firewall.

Using its Application Layer Gateway (ALG) capability, the firewall can inspect the traffic that runs through it to determine if that traffic is really the type of traffic that the firewall is expecting. For example, does the HTTP traffic really look like HTTP traffic, or is it an attack? If it is an attack, then drop that packet and do not allow that packet to get to the HTTP server behind the firewall.

**Overall Disadvantages of Firewalls**

Not all IP Telephony application servers or applications are supported through a firewall. Some applications that are not supported with firewalls or with an ALG in the firewall include Cisco Unity voicemail servers, Attendant Console, Cisco Unified Contact Center Enterprise, and Cisco Unified Contact Center Express. ACLs can be written for these applications to allow traffic to flow through a firewall.

**Note**

The timers for failover on the firewalls (FWSM and ASA) are set quite high by default. To keep from affecting voice RTP streams as they go through the firewall if there is a failover, Cisco recommends reducing those timer settings to less than one second. If this is done, and if there is a failover, the amount of time that the RTP streams could be affected will be less because the firewalls will fail-over quicker and there will be less impact on the RTP streams during the failover time.

Versions of Cisco FWSM prior to version 3.0 do not support SCCP fragmentation. If an SCCP packet is fragmented from a phone, from Unified CM, or from a gateway to another IP Telephony device, the fragmented packet will not be allowed through the FWSM. In cases where fragmentation occurs with an FWSM running version 2.x code, an ACL should be used without the ALG feature of the firewall for the signaling traffic. This configuration will allow the signaling traffic through the FWSM but will not do packet inspection as the signaling goes through the firewall.

If there are other applications that use the same port as SCCP (TCP 2000), those applications could be affected by the SCCP inspection. All traffic that is going to the SCCP TCP port will be inspected to see if it is SCCP traffic. If it is not SCCP traffic, it will be dropped.

To determine if the applications running on your network are supported with the version of firewall in the network or if ACLs have to be written, refer to the appropriate application documentation available at

<http://www.cisco.com>

## Routed ASA and PIX

The ASA or PIX firewall in routed mode acts as a router between connected networks, and each interface requires an IP address on a different subnet. In single-context mode, the routed firewall supports Open Shortest Path First (OSPF) and Routing Information Protocol (RIP) in passive mode. Multiple-context mode supports static routes only. ASA version 8.x also supports Enhanced Interior Gateway Routing Protocol (EIGRP). Cisco recommends using the advanced routing capabilities of the upstream and downstream routers instead of relying on the security appliance for extensive routing needs. For more information on the routed mode, refer to the *Cisco Security Appliance Command Line Configuration Guide*, available at

[http://www.cisco.com/en/US/products/ps6120/products\\_installation\\_and\\_configuration\\_guides\\_list.html](http://www.cisco.com/en/US/products/ps6120/products_installation_and_configuration_guides_list.html)

### Advantages

The routed ASA or PIX firewall supports QoS, NAT, and VPN termination to the box, which are not supported in the transparent mode (see [Transparent ASA and PIX, page 19-34](#)).

[Figure 19-16](#) shows the logical placement of firewalls for both routed and transparent configurations in active standby mode. With the routed configuration, each interface on the ASA or PIX would have an IP address. In the transparent mode, there would be no IP address on the interfaces other than the IP address to manage the ASA or PIX remotely.

### Disadvantages

Unlike with transparent mode, the device can be seen in the network and, because of that, it can be a point of attack. Placing a routed ASA or PIX firewall in a network changes the network routing because some of the routing can be done by the firewall. IP addresses must also be available for all the interfaces on the firewall that are going to be used, so changing the IP addresses of the routers in the network might also be required. If a routing protocol or RSVP is to be allowed through the ASA or PIX firewall, then an ACL will have to be put on the inside (or most trusted) interface to allow that traffic to pass to the outside (or lesser trusted) interfaces. That ACL must also define all other traffic that will be allowed out of the most trusted interface.

## Transparent ASA and PIX

The ASA or PIX firewall can be configured to be a Layer 2 firewall (also known as "bump in the wire" or "stealth firewall"). In this configuration, the firewall does not have an IP address (other than for management purposes), and all of the transactions are done at Layer 2 of the network. Even though the firewall acts as a bridge, Layer 3 traffic cannot pass through the security appliance unless you explicitly permit it with an extended access list. The only traffic allowed without an access list is Address Resolution Protocol (ARP) traffic.

### Advantages

This configuration has the advantage that an attacker cannot see the firewall because it is not doing any dynamic routing. Static routing is required to make the firewall work even in transparent mode.

This configuration also makes it easier to place the firewall into an existing network because routing does not have to change for the firewall. It also makes the firewall easier to manage and debug because it is not doing any routing within the firewall. Because the firewall is not processing routing requests, the performance of the firewall is usually somewhat higher with **inspect** commands and overall traffic than the same firewall model and software that is doing routing.

### Disadvantages

With transparent mode, you are unable to use NAT on the firewall. If you are going to pass data for routing, you will also have to define the ACLs both inside and outside the firewall to allow traffic, unlike with the same firewall in routed mode. Cisco Discovery Protocol (CDP) traffic will not pass through the device even if it is defined. Each directly connected network must be on the same subnet. You cannot share interfaces between contexts; if you plan on running multiple-context mode, you will have to use additional interfaces. You must define all non-IP traffic, such as routing protocols, with an ACL to allow that traffic through the firewall. QoS is not supported in transparent mode. Multicast traffic can be allowed to go through the firewall with an extended ACL, but it is not a multicast device. In transparent mode, the firewall does not support VPN termination other than for the management interface.

If a routing protocol or RSVP is to be allowed through the ASA or PIX firewall, then an ACL will have to be put on the inside (or most trusted) interface to allow that traffic to pass to the outside (or lesser trusted) interfaces. That ACL must also define all other traffic that will be allowed out of the most trusted interface.

For more information on the transparent mode, refer to the *Cisco Security Appliance Command Line Configuration Guide*, available at

[http://www.cisco.com/en/US/products/ps6120/products\\_installation\\_and\\_configuration\\_guides\\_list.html](http://www.cisco.com/en/US/products/ps6120/products_installation_and_configuration_guides_list.html)

## ASA TLS Proxy Feature

This feature adds the capability for an ASA firewall to perform inspection of encrypted voice signaling. When an endpoint device is configured for encrypted signaling, an Application Layer gateway is unable to perform functions such as NAT fixup because it is unable to inspect the signaling. The TLS proxy feature allows the ASA to participate in the TLS session over which the signaling is sent, and the ASA is then able to decode the signaling stream, perform any necessary fixup, and then re-encrypt the signaling.

When the ASA firewall is placed between an IP phone and the Unified CM to which it is registered, the TLS proxy is inserted into the TLS session. A phone with encrypted signaling uses TLS as a transport between itself and Unified CM. When the TLS proxy is involved, there are two TLS sessions for each phone registration, one between the phone and the ASA and the second between the ASA and Unified CM.

The ASA is the only firewall with an ALG that has a controlled method to allow a call with encrypted signaling to work, because it is able to inspect that signaling.

When a VPN design is not the desired solution for securing remote phones, the ASA can provide an alternative method of securing those devices.

The TLS proxy is added as a trusted entity to the Certificate Trust List (CTL) that is used by the phones. The CTL file is allowed to contain 16 entries which include all servers that need to have a trust relationship with the phones. Therefore, the number of TLS proxies configured to work with a given cluster is limited by the number of free entries in the Certificate Trust List.

## ASA and PIX Configuration Example

The following configuration example lists the ports and **inspect** commands that are used to make the firewalls work with voice for ASA and PIX software Release 7.04. This is an example only, and you should review the ports list from all the applications that are used in your network before deploying any firewall. This configuration example shows only the voice sections.

```

!
!
object-group service remote-access tcp
  description remote access
  !Windows terminal
  port-object range 3389 3389
  !VNC
  port-object range 5800 5800
  !VNC
  port-object range 5900 5900
  port-object range 8080 8080
  port-object eq ssh
  !SSH
  port-object eq ftp-data
  !FTP data transport
  port-object eq www
  !HTTP Access
  port-object eq ftp
  !FTP
  port-object eq https
  !HTTPS Access
object-group service voice-protocols-tcp tcp
  description TCP voice protocols
  CTI/QBE
  port-object range 2428 2428
  !SIP communication
  port-object eq ctiqbe
  !SCCP
  port-object range 2000 2000
  !Secure SCCP
  port-object range 2443 2443
object-group service voice-protocols-udp udp
  !TFTP
  port-object eq tftp
  !MGCP Signaling
  port-object range 2427 2427
  !DNS
  port-object eq domain
  !RAS
  port-object range 1719 1719
  !SIP

!Object Group applied for remote-access
access-list OUTSIDE extended permit tcp any any object-group remote-access
!Object Group applied for voice-protocols-tcp
access-list OUTSIDE extended permit tcp any any object-group voice-protocols-tcp
!Object Group applied for voice-protocols-udp
access-list OUTSIDE extended permit udp any any object-group voice-protocols-udp
! Object Group applied for remote-access
access-list inside_access_in extended permit tcp any any object-group remote-access
! Object Group applied for voice-protocols-tcp
access-list inside_access_in extended permit tcp any any object-group voice-protocols-tcp
! Object Group applied for voice-protocols-udp
access-list inside_access_in extended permit udp any any object-group voice-protocols-udp

```

```

!Failover config
ip address 172.19.245.3 255.255.255.248 standby 172.19.245.4
failover
failover lan unit primary
failover lan interface failover GigabitEthernet0/3
failover polltime unit 1 holdtime 3
!Lowest and fastest setting for failover
failover polltime interface 3
failover link failover_state GigabitEthernet0/2
failover interface ip failover 192.168.1.1 255.255.255.0 standby 192.168.1.2
failover interface ip failover_state 192.168.0.1 255.255.255.0 standby 192.168.0.2

!
!Default inspection with inspects enabled
class-map inspection_default
  match default-inspection-traffic
!
!
policy-map global_policy
  class inspection_default
    inspect h323 h225
    inspect h323 ras
    inspect skinny
    inspect sip
    inspect tftp
    inspect mgcp

```

## FWSM Routed Mode

In routed mode, the FWSM is considered to be a router hop in the network. It performs NAT between connected networks and can use OSPF or passive RIP (in single-context mode). Routed mode supports up to 256 interfaces per context or in single mode, with a maximum of 1000 interfaces divided between all contexts.

### Advantages

As a routed device in your network, the FWSM supports routing and all other features that are not available in transparent mode.

### Disadvantages

Unlike the transparent mode, the routed device is visible in the network and, because of that, it can be a point of attack. To place the device in a network, IP addressing and routing must be changed.

## FWSM Transparent Mode

In transparent mode, the FWSM acts like a "bump in the wire," or a "stealth firewall," and is not a router hop. The FWSM connects the same network on its inside and outside interfaces, but each interface must be on a different VLAN. No dynamic routing protocols or NAT are required. However, like routed mode, transparent mode also requires ACLs to allow traffic to pass through. Transparent mode can also optionally use EtherType ACLs to allow non-IP traffic. Transparent mode supports only two interfaces, an inside interface and an outside interface.

You might use a transparent firewall to simplify your network configuration. Transparent mode is also useful if you want the firewall to be invisible to attackers. You can also use a transparent firewall for traffic that would otherwise be blocked in routed mode. For example, a transparent firewall can allow multicast streams using an EtherType ACL.

### Advantages

This configuration has the advantage that an attacker cannot see the firewall because it is not doing any routing. This configuration also makes it easier to place the firewall into an existing network because routing does not have to change for the firewall. It also makes the firewall easier to manage and debug because it is not doing any routing within the firewall. You can also bridge non-IP traffic and IP multicast traffic, static ARP inspection, and MAC move detection and static MAC.

### Disadvantages

To avoid loops when you use failover in transparent mode, you must use switch software that supports Bridge Port Data Unit (BPDU) forwarding, and you must configure the FWSM to allow BPDUs. Transparent mode does not support NAT, dynamic routing, or a unicast reverse path forwarding (RPF) check. There is no NAT 0 with the FWSM in transparent mode.

## FWSM Configuration Example

The following configuration example lists the ports and **inspect** commands that are used to make the firewalls work with voice for FWSM software Release 2.3.x. This is only an example, and you should review the ports list from all the applications that are used in your network before deploying any firewall. This configuration example shows only the voice sections.

```
fixup protocol h323 H225 1720
!Enable fixup h3232 h225

fixup protocol h323 ras 1718-1719
!Enable fixup h323 RAS

fixup protocol mgcp 2427
!Enable fixup mgcp

fixup protocol skinny 2000
!Enable fixup

fixup protocol tftp 69
!Enable fixup

object-group service VoiceProtocols tcp
  description Unified CM Voice protocols
  port-object eq ctigbe
  port-object eq 2000
  port-object eq 3224
  port-object eq 2443
  port-object eq 2428
  port-object eq h323
!Defining the ports for TCP voice

object-group service VoiceProtocolsUDP udp
  description UDP based Voice Protocols
  port-object range 2427 2427
  port-object range 1719 1719
  port-object eq tftp
!Defining the ports for UDP voice
```

```

object-group service RemoteAccess tcp
  description Remote Acces
  port-object range 3389 3389
  port-object range 5800 5809
  port-object eq ssh
  port-object range 5900 5900
  port-object eq www
  port-object eq https
!Defining remote access TCP ports

access-list inside_nat0_outbound extended permit ip any any
!

access-list phones_access_in extended permit tcp any any object-group RemoteAccess log
notifications interval 2
access-list phones_access_in extended permit tcp any any object-group VoiceProtocols log
notifications interval 2
access-list phones_access_in extended permit udp any any object-group VoiceProtocolsUDP
log notifications interval 2
access-list phones_access_in extended deny ip any any log notifications interval 2
access-list outside_access_in extended permit tcp any any object-group VoiceProtocols log
notifications interval 2
access-list outside_access_in extended permit tcp any any object-group RemoteAccess log
notifications interval 2
access-list outside_access_in extended permit udp any any object-group VoiceProtocolsUDP
log notifications interval 2
!Access lists applying the object groups defined above for inside and outside interfaces

access-list outside_access_in extended deny ip any any log notifications interval 2
access-list inside_access_in extended deny ip any any
!Deny all other traffic

access-list phones_nat0_outbound extended permit ip any any
!

failover
failover lan unit primary
failover lan interface flin vlan 4050
failover polltime unit 1 holdtime 5
failover polltime interface 15
!Failover config - 15 seconds
failover interface-policy 50%
failover link flin vlan 4051
failover interface ip flin 1.1.1.1 255.255.255.252 standby 1.1.1.2
failover interface ip flin 1.1.1.5 255.255.255.252 standby 1.1.1.6
nat (inside) 0 access-list inside_nat0_outbound_V1
access-group outside_access_in in interface outside
access-group inside_access_in in interface inside

```

## Data Center

Within the data center, the security policy should define what security is needed for the IP Telephony applications servers. Because the Cisco Unified Communications servers are based on IP, the security that you would put on any other time-sensitive data within a data center could be applied to those servers as well.

If clustering over the WAN is being used between data centers, any additional security that is applied both within and between those data centers has to fit within the maximum round-trip time that is allowed between nodes in a cluster. If your current security policy for application servers within your network covers the IP Telephony servers from Cisco, then you should use that security. You can also use any of the infrastructure security that is already deployed.

To design appropriate data center security for your data applications, Cisco recommends following the guidelines presented in the *Data Center Networking: Server Farm Security SRND (Server Farm Security in the Business Ready Data Center Architecture)*, available at

<http://www.cisco.com/go/designzone>

## Applications Servers

For a list of the Unified CM security features and how to enable them, refer to the *Cisco Unified Communications Manager Security Guide*, available at

[http://www.cisco.com/en/US/products/sw/voicesw/ps556/prod\\_maintenance\\_guides\\_list.html](http://www.cisco.com/en/US/products/sw/voicesw/ps556/prod_maintenance_guides_list.html)

Before enabling any of the Unified CM security features, verify that they will satisfy the security requirements specified in your enterprise security policy for these types of devices in a network.

## Cisco Security Agent on the Unified CM and Application Servers

The Cisco Security Agent is used on most of the application servers that Cisco uses to provide IP Telephony and IP Telephony services. The Cisco Security Agent software is Host Intrusion Prevention software that looks at the behavior of the traffic to and from the server, and the way the applications are running on that server, to determine if everything is working correctly. If something is considered abnormal, then the Cisco Security Agent software prevents that activity from happening.

### Unmanaged Cisco Security Agent

Cisco developed a default Cisco Security Agent policy for its servers that allows all the correct things needed for that IP Telephony server to function, while also preventing known and unknown attacks from affecting the IP Telephony servers. This software protects the application and the operating system from both viruses and worm attacks. To get the maximum protection from these types of intrusions, ensure that the newest version of the Cisco Security Agent software is always installed on your servers. With the unmanaged agent installed on your servers, you will be able to see the logs of attacks on only the system where the agent is installed. You will have to log into each system to check the log files that might be there because of some type of alarm that has occurred. The unmanaged Cisco Security Agent is installed by default when you install Unified CM.

#### Advantages

The unmanaged Cisco Security Agent protects each system from both known and unknown attacks, worms, and viruses.

#### Disadvantages

When run in unmanaged mode, Cisco Security Agent does not correlate alarms, and you have to access each system individually to see the log files on that system.

## Managed Cisco Security Agent

**Note**

---

Cisco Unified CM 7.x currently does *not* support managed Cisco Security Agent capability.

---

## Antivirus

**Note**

---

Cisco Unified CM 7.x currently does *not* support the use of antivirus software.

---

## General Server Guidelines

Your Unified CM and other IP Telephony application servers should not be treated as normal servers. Anything you do while configuring the system could affect calls that are trying to be places or that are in progress. As with any other business-class application, major configuration changes should be done within maintenance windows to keep from disrupting phone conversations.

Standard security policies for application servers might not be adequate for IP Telephony servers. Unlike email servers or web servers, voice servers will not allow you to refresh a screen or re-send a message. The voice communications are real-time events. Any security policy for IP Telephony servers should ensure that work that is not related to configuring or managing the voice systems is not done on the IP Telephony servers at any time. Activities that might be considered normal on application servers within a network (for example, surfing the internet) should not take place on the IP Telephony servers.

In addition, Cisco provides a well defined patch system for the IP Telephony servers, and it should be applied based on the patch policy within your IT organization. You should not patch the system normally using the OS vendor's patch system unless it is approved by Cisco Systems. All patches should be downloaded from Cisco or from the OS vendor as directed by Cisco Systems, and applied according to the patch installation process.

To receive security alerts, you can subscribe to the Cisco Notification service at:

<http://www.cisco.com/cisco/support/notifications.html>

**Note**

---

A Cisco.com login account is required for access to this link.

---

The above site also contains a notification tool that will email you when a critical patch must be applied to an IP Telephony server.

### Advantages

General server security practices help to mitigate viruses and worms if the application server is treated like a PBX and not like other application servers.

### Disadvantages

When the additional security features are configured, some of the Unified CM functionality might be reduced. Also, additional care is needed during upgrades because some of the services that are disabled for the additional security will have to be enabled for a successful upgrade.

# Deployment Examples

This section presents examples of what could be done from a security perspective for a lobby phone and a firewall deployment. A good security policy should be in place to cover deployments similar to these types.

## Lobby Phone Example

The example in this section illustrates one possible way to configure a phone and a network for use in an area with low physical security, such as a lobby area. None of the features in this example are required for a lobby phone, but if your security policy states more security is needed, then you could use the features listed in this example.

Because you would not want anyone to gain access to the network from the PC port on the phone, you should disable the PC port on the back of the phone to limit network access (see [PC Port on the Phone, page 19-6](#)). You should also disable the settings page on the phone so that potential attackers cannot see the IP addresses of the network to which the lobby phone is connected (see [Settings Access, page 19-9](#)). The disadvantage of not being able to change the settings on the phone usually will not matter for a lobby phone.

Because there is very little chance that a lobby phone will be moved, you could use a static IP address for that phone. A static IP address would prevent an attacker from unplugging the phone and then plugging into that phone port to get a new IP address (see [IP Addressing, page 19-5](#)). Also, if the phone is unplugged, the port state will change and the phone will no longer be registered with Unified CM. You can track this event in just the lobby phone ports to see if someone is trying to attach to the network.

Using static port security for the phone and not allowing the MAC address to be learned would mean that an attacker would have to change his MAC address to that of the phone, if he were able to discover that address. Dynamic port security could be used with an unlimited timer to learn the MAC address (but never unlearn it), so that it would not have to be added. Then the switchport would not have to be changed to clear that MAC address unless the phone is changed. The MAC address is listed in a label on the bottom of the phone. If listing the MAC address is considered a security issue, the label can be removed and replaced with a "Lobby Phone" label to identify the device. (See [Switch Port, page 19-12](#).)

A single VLAN could be used and Cisco Discovery Protocol (CDP) could be disabled on the port so that attackers would not be able to see any information from the Ethernet port about that port or switch to which it is attached. In this case, the phone would not have a CDP entry in the switch for E911 emergency calls, and each lobby phone would need either a label or an information message to local security when an emergency number is dialed.

A static entry in the DHCP Snooping binding table could be made because there would be no DHCP on the port (see [DHCP Snooping: Prevent Rogue DHCP Server Attacks, page 19-16](#)). Once the static entry is in the DHCP Snooping binding table, Dynamic ARP Inspection could be enabled on the VLAN to keep the attacker from getting other information about one of the Layer 2 neighbors on the network (see [Requirement for Dynamic ARP Inspection, page 19-20](#)).

With a static entry in the DHCP Snooping binding table, IP Source Guard could be used (see [IP Source Guard, page 19-22](#)). If an attacker got the MAC address and the IP address and then started sending packets, only packets with the correct IP address could be sent.

A VLAN ACL could be written to allow only the ports and IP addresses that are needed for the phones to operate (see [VLAN Access Control Lists, page 19-24](#)). The following example contains a very small ACL that can be applied to a port at Layer 2 or at the first Layer 3 device to help control access into the network (see [Router Access Control Lists, page 19-26](#)). This example is based on a Cisco 7960 IP Phone being used in a lobby area, without music on hold to the phone or HTTP access from the phone.

This example uses the following IP address ranges:

- The lobby phone has an IP address of 10.0.40.5
- The Unified CM cluster uses the address range 10.0.20.\*
- The DNS server has an IP address of 10.0.30.2
- The HSRP routers have IP addresses 10.0.10.2 and 10.0.10.3
- Other phones in the network use IP addresses in the range 10.0.\*.\*

```
10 permit icmp any any
! Allow all icmp - phone to phone, gateway to phone and NMS to phone

20 permit udp host 10.0.10.2 eq 1985 any
!Allow HSRP information in, do not allow out

30 permit udp host 10.0.10.3 eq 1985 any
! Allow in from HSRP neighbor

40 permit udp host 10.0.40.5 range 32768 61000 10.0.20.0 0.0.0.255 eq tftp
! Using ip host from ephemeral port range from phone to the TFTP server port 69 (start of tftp)

50 permit udp 10.0.20.0 0.0.0.255 range 1024 5000 host 10.0.40.5 range 32768 61000
!Using IP subnet from TFTP server with ephemeral port range to ip host and ephemeral port range for phone

60 permit udp host 10.0.40.5 range 32768 61000 10.0.20.0 0.0.0.255 range 1024 5000
! Using host from phone to TFTP server with ephemeral port range to ip range and ephemeral port range for TFTP (continue the TFTP conversation)

70 permit udp host 10.0.40.5 range 32768 61000 host 10.0.30.2 eq domain
! Using IP host and ephemeral port range from phone to DNS server host

80 permit udp host 10.0.30.2 eq domain host 10.0.40.5 range 32768 61000
! Using IP from DNS server to phone host ip and ephemeral port range

90 permit tcp 10.0.40.5 range 32768 61000 10.0.20.0 0.0.0.255 eq 2000
! Using IP host and ephemeral port range from phone to Unified CM cluster for SCCP

100 permit tcp 10.0.20.0 0.0.0.255 eq 2000 host 10.0.40.5 range 32768 61000
! Using IP range and SCCP port to phone IP host and ephemeral port range

110 permit udp 10.0.0.0 0.0.255.255 range 16384 32767 host 10.0.40.5 range 16384 32767
! Using IP range and ephemeral port range from all phones or gateways outside a vlan to the IP host to phone

120 permit udp host 10.0.40.5 range 16384 32767 10.0.0.0 0.0.255.255 range 16384 43767
! Using IP host and ephemeral port range from vlan to all other phones or gateways

130 permit udp host 172.19.244.3 range 1024 5000 host 10.0.40.5 eq snmp
!From IP host of NMS server and ephemeral port range (Different for Windows vs Sun) to IP host of phones and SNMP port (161)

140 permit udp host 10.0.40.5 eq snmp host 172.19.244.3 range 1024 5000
! From IP host of phone with SNMP port (161) to IP host of NMS server and ephemeral port range
```

### Basic QoS Example for a Lobby Phone

Set the voice stream to G.729 and use QoS to limit the amount of traffic that can be sent into the port (see [Quality of Service, page 19-24](#)). Even if the QoS maximum is exceeded, the traffic will be reset to CS1, or Scavenger Class, which is the lowest priority traffic in most enterprise networks.

```
CAT2970(config)#mls qos map policed-dscp 0 24 46 to 8
! Excess traffic marked 0 or CS3 or EF will be remarked to CS1
CAT2970(config)#
CAT2970(config)#class-map match-all LOBBY-VOICE
CAT2970(config-cmap)# match access-group name LOBBY-VOICE
CAT2970(config-cmap)#class-map match-all LOBBY-SIGNALING
CAT2970(config-cmap)# match access-group name LOBBY-SIGNALING
CAT2970(config-cmap)#exit
CAT2970(config)#
CAT2970(config)#policy-map LOBBY-PHONE
CAT2970(config-pmap)#class LOBBY-VOICE
CAT2970(config-pmap-c)# set ip dscp 46 ! Lobby phone VoIP is marked to DSCP EF
CAT2970(config-pmap-c)# police 48000 8000 exceed-action policed-dscp-transmit
! Out-of-profile Lobby voice traffic (g.729) is marked down to Scavenger (CS1)
CAT2970(config-pmap-c)#class LOBBY-SIGNALING
CAT2970(config-pmap-c)# set ip dscp 24 ! Signaling is marked to DSCP CS3
CAT2970(config-pmap-c)# police 32000 8000 exceed-action policed-dscp-transmit
! Out-of-profile Signaling traffic is marked down to Scavenger (CS1)
CAT2970(config-pmap-c)#class class-default
CAT2970(config-pmap-c)# set ip dscp 0
CAT2970(config-pmap-c)# police 56000 8000 exceed-action policed-dscp-transmit
! Out-of-profile data traffic is marked down to Scavenger (CS1)
CAT2970(config-pmap-c)# exit
CAT2970(config-pmap)#exit
CAT2970(config)#
CAT2970(config)#interface GigabitEthernet0/1
CAT2970(config-if)# service-policy input LOBBY-PHONE ! Applies policy to int
CAT2970(config-if)#exit
CAT2970(config)#
CAT2970(config)#ip access list extended LOBBY-VOICE
CAT2970(config-ext-nacl)# permit udp any any range 16384 32767 ! VoIP ports
CAT2970(config-ext-nacl)#
CAT2970(config-ext-nacl)#ip access list extended LOBBY-SIGNALING
CAT2970(config-ext-nacl)# permit tcp any any range 2000 2002 ! SCCP ports
CAT2970(config-ext-nacl)#end
CAT2970#
```

## Firewall Deployment Example (Centralized Deployment)

The example in this section is one way that firewalls could be deployed within the data center, with Unified CMs behind them (see [Figure 19-19](#)). In this example, the Unified CMs are in a centralized deployment, single cluster with all the phones outside the firewalls. Because the network in this deployment already contained firewalls that are configured in routed mode within the corporate data center, the load was reviewed before the placement of gateways was determined. After reviewing the average load of the firewall, it was decided that all the RTP streams would not transverse the firewall in order to keep the firewalls under the 60% CPU load (see [Putting Firewalls Around Gateways, page 19-29](#)). The gateways are placed outside the firewalls, and ACLs within the network are used to control the TCP data flow to and from the gateways from the Unified CMs. An ACL is also written in the network to control the RTP streams from the phones because the IP addresses of the phones are well defined (see [IP Addressing, page 19-5](#)). The voice applications servers are placed within the demilitarized zone (DMZ), and ACLs are used at the firewalls to control access to and from the

Unified CMs and to the users in the network. This configuration will limit the amount of RTP streams through the firewall using inspects, which will minimize the impact to the firewalls when the new voice applications are added to the existing network.

**Figure 19-19 Firewall Deployment Example**

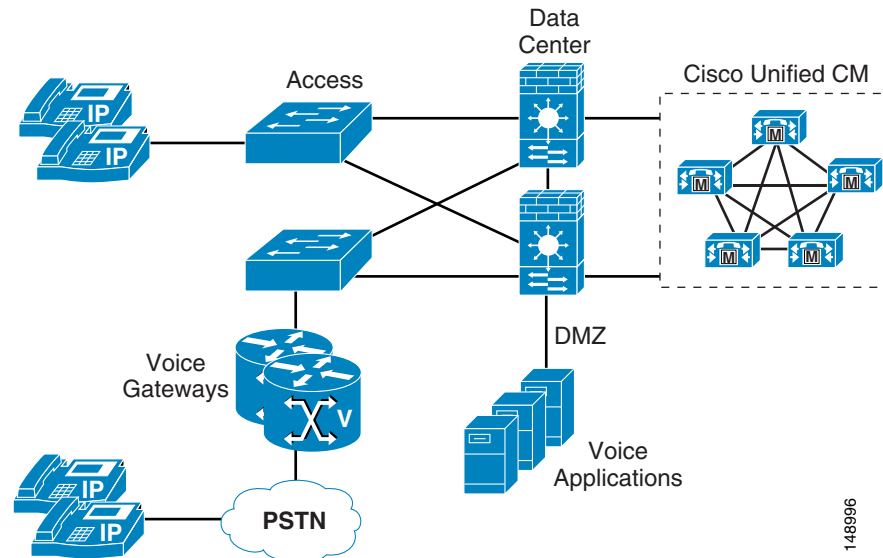

## Securing Network Virtualization

This section describes the challenges with providing homogenous connectivity for communications between virtual networks and a technique for overcoming these challenges. It assumes familiarity with Virtual Route Forwarding and Network Virtualization. Network design principles for these technologies are described in the Network Virtualization documentation available at <http://www.cisco.com/go/designzone>.

This discussion is not meant as an endorsement to use virtualization as a method to increase the security of a Unified Communications solution. Its purpose is to explain how such deployments can layer Unified Communications onto the existing infrastructure. Refer to the Network Virtualization documentation for evaluating the advantages and disadvantages of virtualization technology.

When a network is based on virtualization technology, there is a logical separation of traffic at Layer 3, and separate routing tables exist for each virtual network. Due to the lack of routing information, devices in different virtual networks cannot communicate with one another. This environment works well for client-server deployments where all user endpoints communicate with devices in the data center only, but it has issues for providing peer-to-peer communication. Regardless of how the virtual networks are arranged – whether by department, location, type of traffic (data or voice), or some other basis – the core issue is the same: endpoints in different Virtual Private Network Routing and Forwarding tables (VRFs) do not have the capability to communicate to one another. [Figure 19-20](#) shows a solution that uses a shared VRF located in the data center to provide connectivity between a software-based phone located in one VRF and a hardware phone located in another VRF. This solution may also apply to other variants of this situation. Network Virtualization requires that fire-walling of the data center be implemented for the demarcation between the data center and the campus networks, and the following discussion shows how this can be implemented.

## Scenario 1: Single Data Center

Figure 19-20 Single Data Center

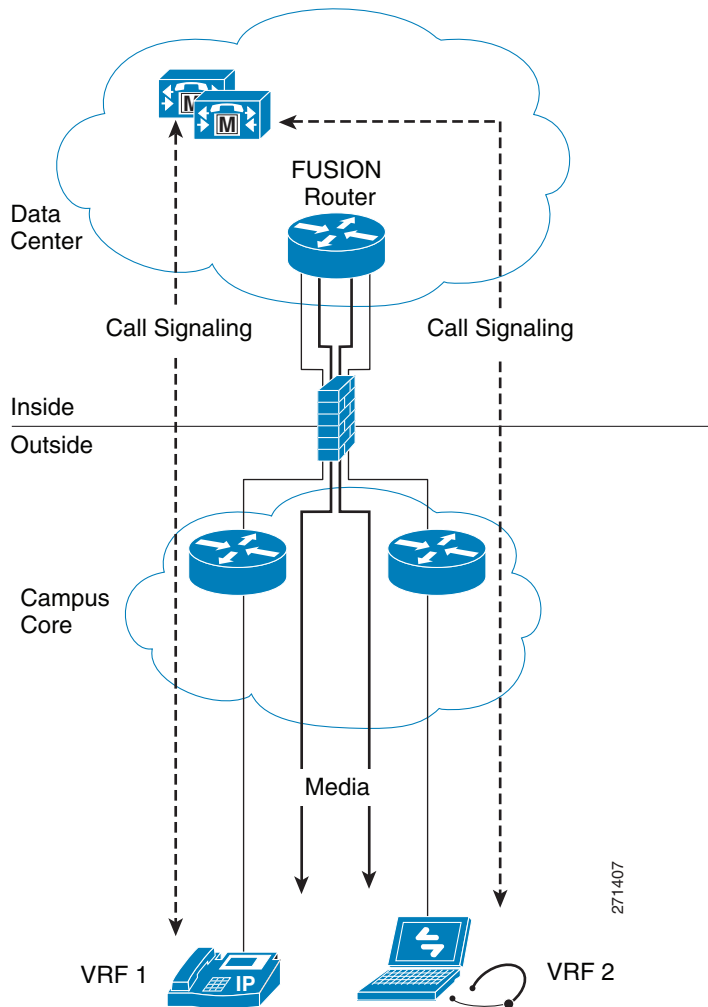

This scenario is the simplest to implement and is an incremental configuration change beyond the usual network virtualization implementation. This design incorporates a data center router with the capability to route packets to any VRF, and it is called the fusion router. (Refer to the Network Virtualization documentation for details on the configuration of the fusion router.) The deployment scenario for enabling peer-to-peer communications traffic utilizes the fusion router for routing between VRFs and the firewall capabilities for securing access to the data center.

The following base requirements apply to this scenario:

- Campus routers send packets for other campus VRFs toward the fusion router via default routing, so all router hops must route by default to the fusion router. The data center shared VRF has route information about each campus VRF. All VRFs other than the shared VRF have no direct connectivity.
- A Unified CM cluster is located in a shared VRF in the data center, and communication within that shared VRF is totally unhindered.

- The shared VRF is located in the data center. If multiple data centers exist, the shared VRF spans all the data centers.

The application layer gateway at the data center edge specifies access lists to open ports for TFTP and SCCP or SIP sessions originated on the outside toward the Unified CM cluster in the data center. TFTP is required to allow phones to download their configuration and software images from their TFTP server, and SCCP or SIP is required to allow them to register with the Unified CM cluster. Refer to Unified CM product documentation for a list of appropriate port numbers for the particular version of software used.

In this scenario, all call signaling from communication devices in each VRF passes through the application layer gateway, and inspection of that signaling allows the application layer gateway to dynamically open the necessary UDP pinholes for each VRF for the RTP traffic to pass from the outside of the firewall toward the fusion router. Without the inspection occurring on the firewalls, each RTP stream that originates from an endpoint on the outside is not allowed to pass through the firewall. It is the inspection of the call control signaling that allows the UDP traffic to be forwarded through the firewall.

#### **Advantages**

This deployment model provides a method to allow communication devices on a VRF-enabled network to have peer-to-peer connectivity. The application layer gateway provides secure access to the shared VLAN and the fusion router.

#### **Disadvantages**

All media streams between different VRFs do not take the most direct path between endpoints. The media is backhauled to the data center to be routed via the fusion router.

## **Scenario 2: Redundant Data Centers**

When redundant data centers are involved, the scenario becomes more complicated. It is necessary to ensure that the call setup signaling passes through the same application layer gateway that the corresponding RTP stream is going to use. If the signaling and media take different paths, a UDP pinhole is not opened. [Figure 19-21](#) illustrates an example of a problematic scenario. The hardware phone on the left is controlled by the subscribers in the data center on the left, and the corresponding call control signaling passes through the left firewall. Pinholes are opened in that firewall for the RTP stream. However, the routing might not guarantee that the RTP media stream follows the same path, and the firewall on the right blocks that stream.

Figure 19-21 Call Signaling and Media Take Different Paths

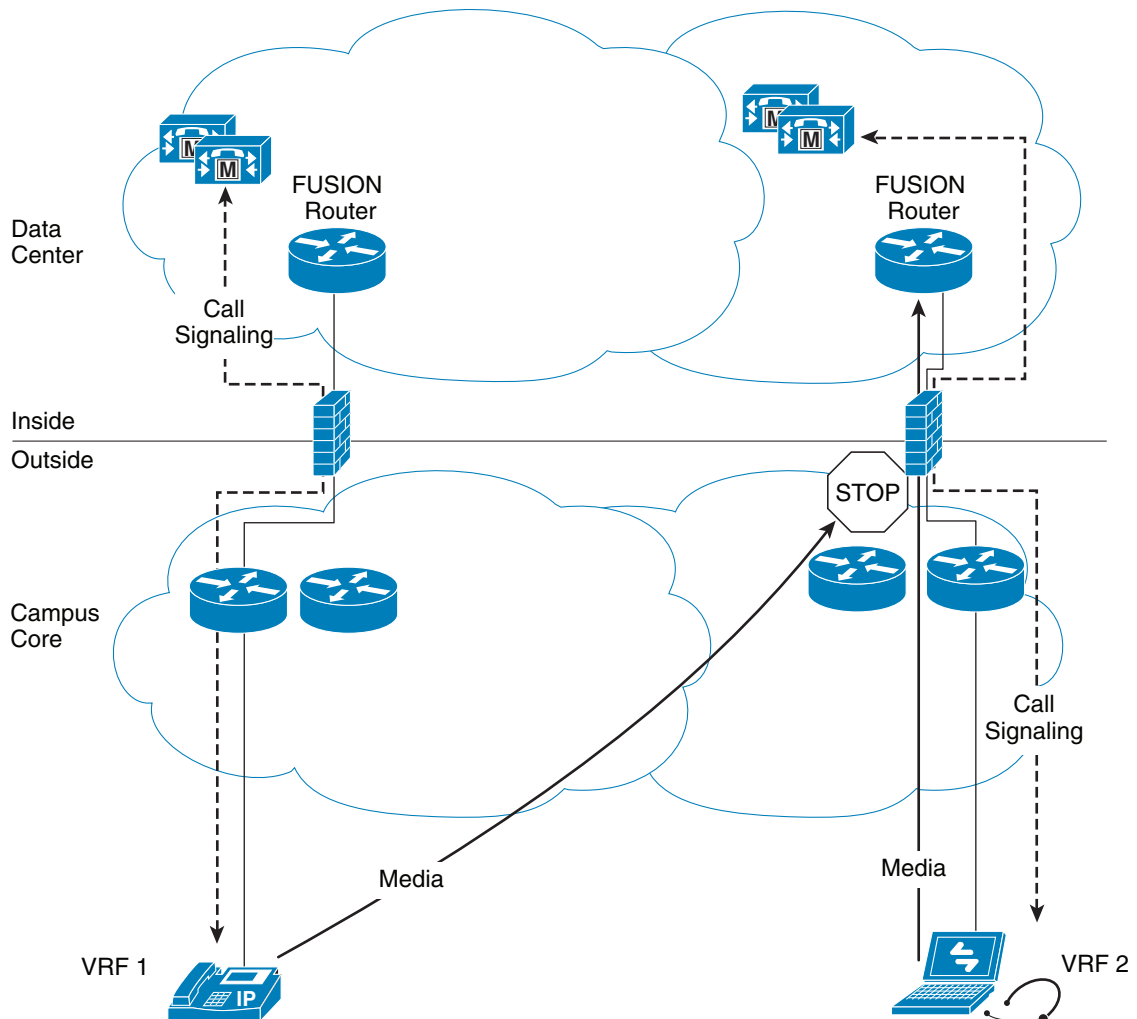

271408

The solution is to utilize Trusted Relay Point (TRP) functionality. (See [Figure 19-22](#).) Subscribers in each data center can invoke TRPs that provide anchoring of the media and ensure that the media streams flow through the appropriate firewall. A phone controlled by a subscriber in the left data center must invoke a TRP in that data center, and a phone controlled by a subscriber in the right data center must invoke a TRP located in the right data center. The TRP provides an IP address that enables a specific host route for media that can ensure the exact same routing path as the call signaling. This is used to ensure that signaling and media pass via the same firewall, thus solving the issue.

Figure 19-22 Redundant Data Centers with TRPs

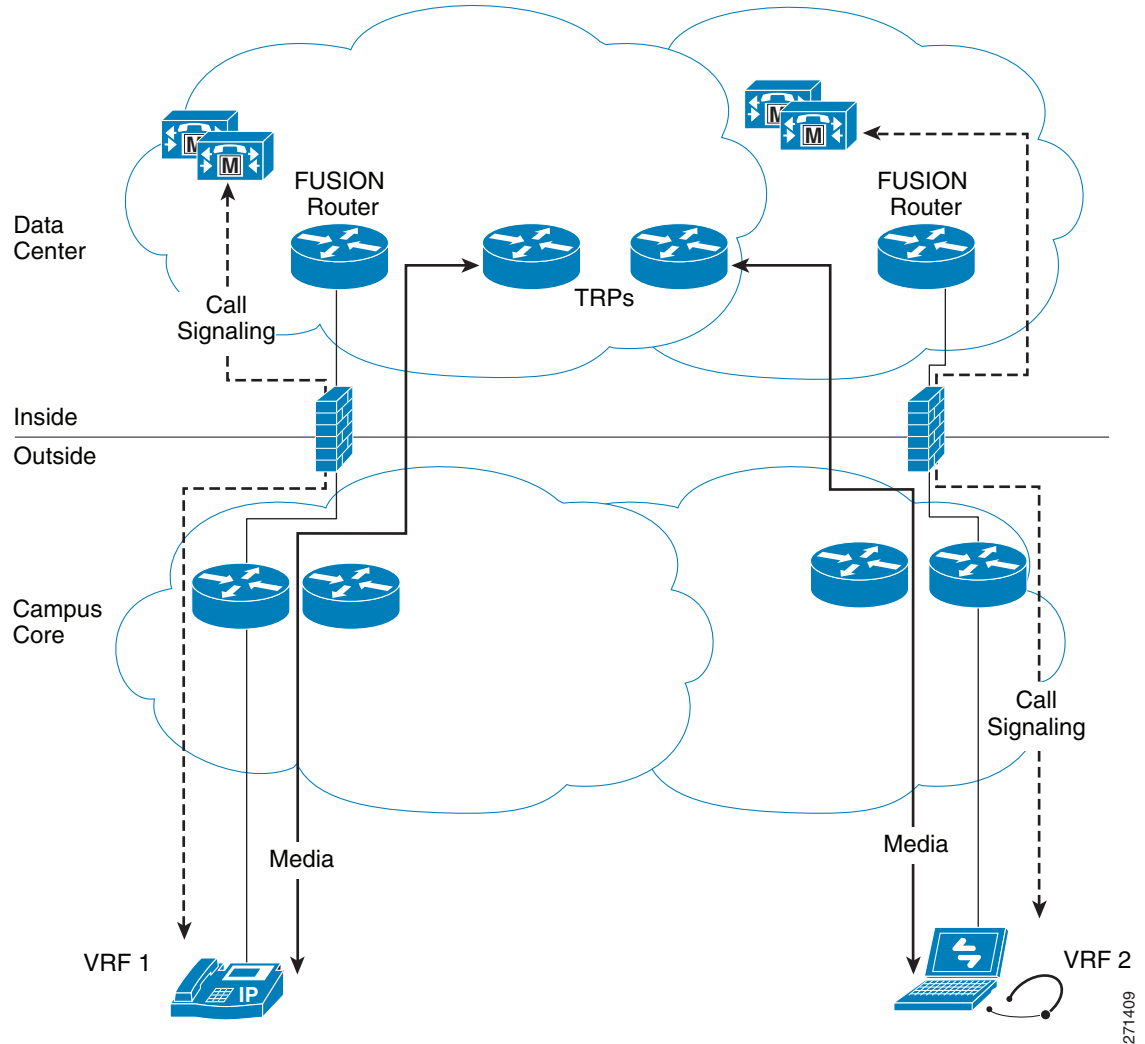

TRPs are media termination point resources that are invoked at the device level for any call involving that device. Each device has a configuration checkbox that specifies whether a TRP should be invoked.

## Conclusion

This chapter did not cover all of the security that could be enabled to protect the voice data within your network. The techniques presented here are just a subset of all the tools that are available to network administrators to protect all the data within a network. On the other hand, even these tools do not have to be enabled within a network, depending on what level of security is required for the data within the network overall. Choose your security methods wisely. As the security within a network increases, so do the complexity and troubleshooting problems. It is up to each enterprise to define both the risks and the requirements of its organization and then to apply the appropriate security within the network and on the devices attached to that network.

