

Cisco CallManager Release Rel 4.1-PBX Interoperability: NEC 2400 IPX R15 to a Cisco 2611XM Using E1 QSIG with MGCP

Introduction

This is an application note for connectivity of an NEC2400 IPX PBX with Cisco CallManager Release 4.1 using Cisco 2611XM-E1 QSIG as MGCP gateway.

The network topology diagram (Figure 1) shows the test setup for end-to-end interoperability with the Cisco CallManager connected to the PBX via 2611XM-E1 QSIG link as MGCP gateway.

Connectivity is achieved by using the PRI QSIG E1 protocol type on the MGCP gateway and QSIG switch type on the NEC2400 IPX PBX.

This Application Note uses the 2611XM-E1 voice gateway, however other Cisco voice gateways are also an option to use since CallManager QSIG implementation does not depend on the physical interface.

Network Topology

Figure 1. Network Topology

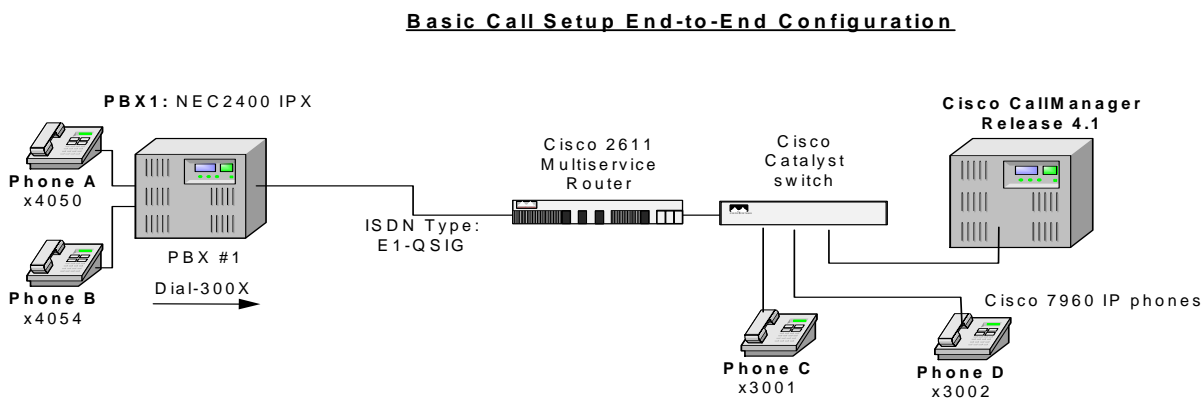



Limitations

Call Transfer (Consultation local Transfer), Phone 'C' calling to phone 'A' that is Transferred to phone 'B', Connected Name and Number are restricted to phone 'C'

Call Transfer (Blind local Transfer), Phone 'C' calling to phone 'A' that is Transferred to phone 'B', Called Number is restricted to phone 'C'

Call Forward Unconditional (local), Phone 'C' calling to phone 'A' that is forwarded to phone 'B', Connected Name is restricted to phone 'C'.

Call Forward Unconditional (Network), Phone 'A' calling to phone 'C' that is forwarded to phone 'B', Calling Name and Forwarding Called Number are not displayed on phone 'B'.

Call Forward Busy (local), Phone 'C' calling to phone 'A' that is Busy forwarded to phone 'B', Forwarding Name is not displayed on phone 'B' and Connected Name is restricted to phone 'C'.

Call Forward Busy (Network), Phone 'C' calling to phone 'A' that is Busy forwarded to phone 'D', Forwarding Name is not displayed on phone 'D'.

Call Forward Busy (Network), Phone 'A' calling to phone 'C' that is Busy forwarded to phone 'B', original Calling Name is not displayed on phone 'B'.

Call Forward No Reply (local), Phone 'C' calling to phone 'A' that is CFNR forwarded to phone 'B', Forwarding Name is not displayed on phone 'B' and Connected Name is restricted to phone 'C'.

Call Forward No Reply (Network), Phone 'C' calling to phone 'A' that is CFNR forwarded to phone 'D', Forwarding Name is not displayed on phone 'D'.

Call Forward No Reply (Network), Phone 'A' calling to phone 'C' that is CFNR forwarded to phone 'B', original Calling Name is not displayed on phone 'B'.

Call back was involked with Call Completion to Busy Subscriber from NEC Phone A to IP Phone C, the original calling name does not display on the final destination phone.

Call back was involked with Call Completion to No Reply from NEC Dterm to IP Phone, the original calling name does not display on the final destination phone.

Path Replacement on a tromboned connection following a Call Transfer was successful. When Path Replacement was complete, however, Name and Number where restricted when path replacement was proposed until the B channels where released.

Tests Restricting Connected Name and Number where not performed.

As of this testing, Reroute was not implemented.



System Components

Hardware Requirements

Cisco Hardware:

Cisco Catalyst switch

Cisco 2611XM

Cisco CallManager 4.1

NEC2400 IPX PBX Hardware:

Software Requirements

PBX Software R15

Cisco CallManager 4.1(3)

Features

CLIP-Calling Line (Number) Identification Presentation

CNIP-Calling Name Identification Presentation

COLP-Connected Line (Number) Identification Presentation

CONP-Connected Name Identification Presentation

Sending Alerting Number

Sending Alerting Name

CT-Call Transfer

CFU-Call Forwarding Unconditional

CFB-Call Forwarding Busy

CFNR-Call Forwarding No Reply

CCBS-Call Completion to Busy Subscriber

CCNR-Call Completion No Reply

ANF-PR-Additional Network Feature Path Replacement (for Trombone connection)



Configuration

Configuration Sequence and Tasks

Configuring the NEC2400 IPX PBX

Calling Name ID Presentation (CNIP)/Connected Name ID Presentation (CONP)

Name ID is assigned by ANDD on each station number basis

ASYD - System Data 1, Index 78, Bit 3: Station number display with 8-character name display. 0/1: Out/In Service.

System Data 1, Index 78, Bit 5: (1) Name Display in service.

System Data 1, Index 79, Bit 6: (0) OAI/ACD in service.

System Data 1, Index 241, Bit 1: User's information display service. 0/1: 8-digit display service/16-digit display service.

ARTD - Assign route class data for the Q-SIG trunk route.

43-BT :1 50-DPLY :1 98-CI :0 112-IND :1

Call Back

ASYD - System Data 1, Index 139. No answer timer for Call Back. Assign 00H. (RAM data is 3FH = 30 seconds.)

System Data 1, Index 68, Bit 0. 0/1: SHF and access code/last digit of telephone number + access code.

System Data 2, Index 0, Bit 0. Is Call Back enabled on a per tenant basis? 0/1: No/Yes.

System Data 2, Index 4, Bit 0. Call Back and Outgoing Trunk Queuing [O-2] access codes are same or separate? 0/1: Separate/Same.

System Data 3, Index 3, Bit 5. Enable Ringer Pattern 5 for Call Back. See Distinctive Ringing

System Data 3, Index 7. Assign data 24H for four seconds ON, two seconds OFF.

System Data 1, Index 5, Bit 7: Call Back - Delay timer: 0/1 = Out/In service.

System Data 1, Index 5, Bits 4 through 6: Delay timer. Value equals two seconds the data set.

ANPD - Reserve a number level for service feature access and cancel. Assign for Normal (N) and Busy (B). Assign NND in accordance with the numbering plan.

ASPA - Assign an access code to Call Back - Entry, SRV = SSC (Service Code), SID = 3 and a Connection Index (CI) for Busy (B) service. For Call Back - Cancel, SRV = SSC (Service Code), SID = 6. Assign a Connection Index (CI) for Normal (N) service.

ASFC - Assign a service feature class that allows SFI 2 (Call Back) to stations to be allowed Call Back.

AKYD - For Dterm sets, Call Back may be assigned to a programmable feature key. Assign Feature Key Call Back [5].

ATNR - Allow TRI 0, Station-to-Station Calling for inter and intra-tenant connections.

Call Completion on No Reply (CCNR)

Assign the basic data for establishing the Q-SIG or the IS-11572 (Layer 3 Specifications for Inter-PBX Signaling Protocol)

ASYD - System Data 1, Index 17, Bit 0. Hooking service while hearing Ringback Tone is available for single line stations? 0/1 = No/Yes.

System Data 1, Index 71, Bits 0 through 3. Assign the timer value of cancel timer for CCNR.

System Data 1, Index 71, Bit 7. Automatic cancel of CCNR. 0/1 = Out/In Service.

System Data 2, Index 4, Bit 0. CCNR and Outgoing Trunk Queuing access code. 0/1 = Separate/



Common.

System Data 3, Index 7. Assign ringer pattern for recalling.

ANPD - Reserve a number level for setting/cancelling CCNR.

ASPA - Assign an access code for setting/cancelling CCNR.

For setting CCNR

CI: Hooking (H)

SRV: 2(SSC)

SID: 3 (Call Back; Entry)

For cancelling CCNR

CI: Normal (N)

SRV: 2(SSC)

SID: 6 (Call Back; Cancel)

Assign service feature class that allows Call Back [SFI 2] to the stations allowed this service.

Call Completion to Busy Subscriber (CCBS)

Assign the basic data for establishing the Q-SIG or the IS-11572 (Layer 3 Specifications for Inter-PBX Signaling Protocol)

ARTD - Assign the following CDN data for the B-Channel route. 43-BT :1

ASYD - System Data 1, Index 68, Bit 0. Operating method for busy station service. 0/1 = SHF + Access Code/Last Digit + Access Code.

System Data 1, Index 71, Bits 0 through 3. Assign the timer value of cancel timer for CCBS.

System Data 1, Index 71, Bit 7. Automatic cancel for CCBS. 0/1 = Out/In Service.

System Data 2, Index 4, Bit 0. CCBS and Outgoing Trunk Queuing access code. 0/1 = Separate/Common.

System Data 3, Index 7. Assign ringer pattern for recalling.

ANPD - Reserve a number level for setting/cancelling CCBS.

ASPA - Assign an access code for setting/cancelling CCBS.

For setting CCBS

CI: Busy (B)

SRV: 2(SSC)

SID: 3 (Call Back; Entry)

For cancelling CCBS

CI: Normal (N)

SRV: 2(SSC)

SID: 6 (Call Back; Cancel)

ASFC - Assign service feature class that allows Call Back [SFI 2] to the stations allowed this service.



Configuration Menus and Commands

NEC 2400 IPX Configuration Menus

[IPX-R15_IP::LTRK]

* Trunk Data List *

Starting

Ending

RT 19

RT 20

RT	TK	LENS	TN
19	1	003121	1
19	2	003122	1
19	3	003123	1
19	4	003124	1
19	5	003125	1
19	6	003126	1
19	7	003127	1
19	8	003130	1
19	9	003131	1
19	10	003132	1
19	11	003133	1
19	12	003134	1
19	13	003135	1
19	14	003136	1



19	15	003137	1
19	16	003141	1
19	17	003142	1
19	18	003143	1
19	19	003144	1
19	20	003145	1
19	21	003146	1
19	22	003147	1
19	23	003150	1
19	24	003151	1
19	25	003152	1
19	26	003153	1
19	27	003154	1
19	28	003155	1
19	29	003156	1
19	30	003157	1
20	1	003140	1
20	2	003120	1

[IPX-R15_IP::LRTD]

* Route Class Data List *



Starting

Ending

RT 19

RT 20

RT 19

CDN	Data	CDN	Data	CDN	Data
001	OSGS 0	043	BT 1	085	CSEU 0
002	ONSG 2	044	PRV 0	086	CSEL 0
003	ISGS 0	045	A/D 1	087	CMP 0
004	INSG 2	046	CW 0	088	TALK 0
005	TF 3	047	TPQ 0	089	FOT 0
006	TCL 4	048	BL 0	090	RST 0
007	L/T 1	049	TRKS 1	091	TOCI 0
008	RLP 2	050	DPLY 1	092	TOCD 0
009	TQ 1	051	ACD 0	093	ODGD 0
010	SMDR 1	052	2W/4W 0	094	RLS 0
011	TD 0	053	FAAT 0	095	GWD 0
012	DR 0	054	GW 0	096	H1 0
013	AC 1	055	TCMA 0	097	DT 0
014	TNT 0	056	SMDR3 0	098	CI 0
015	LSG 12	057	HDT 0	099	OID 0
016	SMDR2 0	058	CD 0	100	TKS 0
017	H/M 0	059	CCH 0	101	PAD2 0



018	MC	0	060	TC/EC	0	102	TRM	0
019	ANI	0	061	IRE	0	103	TRPX	0
020	D	0	062	SCR	0	104	LDR	0
021	MSB	0	063	LYER1	1	105	TSC	0
022	MSW	0	064	NET	0	106	SATS	0
023	TR	0	065	INT	10	107	RVPX	0
024	OC	0	066	DC	4	108	DQ	0
025	R/L	0	067	HKS	0	109	SLOV	0
026	RVSD	0	068	SCF	0	110	SDTO	0
027	TL	0	069	SMDR4	0	111	ADVPR	0
028	ANS	1	070	TCMN	0	112	IND	1
029	TELP	0	071	TCMC	0	113	UUI	0
030	PAD	7	072	MFSP	0	114	DCH	0
031	OGRL	1	073	KPST	0	115	CMRT	0
032	ICRL	1	074	KPPT	0	116	PREF	0
033	HD	0	075	STC	0	117	DFS	0
034	GUARD	1	076	MC2	0	118	BOB	0
035	WINK	0	077	MT	0	119	HOLCH	0
036	VAD	0	078	TONE	0	120	IFR	0
037	CLD	0	079	PPTM	0	121	CONV	0
038	FA	0	080	MPTM	0	122	ORRT	0
039	BC	0	081	LPTM	0	123	CNI	0
040	TCM	0	082	RSAX	0	124	AOC	0
041	TDMQ	0	083	CST	0	125	MGCOT	0



042 TRSC 0 084 CSEG 0

RT 20

CDN		Data	CDN		Data	CDN		Data
001	OSGS	0	043	BT	1	085	CSEU	0
002	ONSG	2	044	PRV	0	086	CSEL	0
003	ISGS	0	045	A/D	1	087	CMP	0
004	INSG	2	046	CW	0	088	TALK	0
005	TF	3	047	TPQ	0	089	FOT	0
006	TCL	4	048	BL	0	090	RST	0
007	L/T	1	049	TRKS	0	091	TOCI	0
008	RLP	2	050	DPLY	0	092	TOCD	0
009	TQ	0	051	ACD	0	093	ODGD	0
010	SMDR	0	052	2W/4W	0	094	RLS	0
011	TD	0	053	FAAT	0	095	GWD	0
012	DR	0	054	GW	0	096	H1	0
013	AC	1	055	TCMA	0	097	DT	0
014	TNT	0	056	SMDR3	0	098	CI	0
015	LSG	13	057	HDT	0	099	OID	0
016	SMDR2	0	058	CD	0	100	TKS	0
017	H/M	0	059	CCH	0	101	PAD2	0
018	MC	0	060	TC/EC	0	102	TRM	0
019	ANI	0	061	IRE	0	103	TRPX	0



020	D	0	062	SCR	0	104	LDR	0
021	MSB	0	063	LYER1	1	105	TSC	0
022	MSW	0	064	NET	0	106	SATS	0
023	TR	0	065	INT	10	107	RVPX	0
024	OC	0	066	DC	4	108	DQ	0
025	R/L	0	067	HKS	0	109	SLOV	0
026	RVSD	0	068	SCF	0	110	SDTO	0
027	TL	0	069	SMDR4	0	111	ADVPR	0
028	ANS	0	070	TCMN	0	112	IND	0
029	TELP	0	071	TCMC	0	113	UUI	0
030	PAD	7	072	MFSP	0	114	DCH	0
031	OGRL	1	073	KPST	0	115	CMRT	0
032	ICRL	1	074	KPPT	0	116	PREF	0
033	HD	0	075	STC	0	117	DFS	0
034	GUARD	1	076	MC2	0	118	BOB	0
035	WINK	0	077	MT	0	119	HOLCH	0
036	VAD	0	078	TONE	0	120	IFR	0
037	CLD	0	079	PPTM	0	121	CONV	0
038	FA	0	080	MPTM	0	122	ORRT	0
039	BC	0	081	LPTM	0	123	CNI	0
040	TCM	0	082	RSAX	0	124	AOC	0
041	TDMQ	0	083	CST	0	125	MGCOT	0
042	TRSC	0	084	CSEG	0			



[IPX-R15_IP::LRTI]

* Trunk Application Data List *

Starting Ending
RT 19 RT 20

RT 19

RST	0	RSCT	0	IDRT	0	COT	0
HMT	0	ROCG	0	ECCISTD	0	SS7	0
TRCRST	0	RICG	0	MFCG2	0	NI2ID	0
TRSRST	0	STSENQ	0	OPCC	0	CLRF	0
T309LNK	0	MMNPASS	0	ICTCON	0	TRC	0
T309CON	0	DLTK	0	VRD	0	OID	0
LLCRST	0	CALN	0	INTD	0	PHG	0
VCM	0	NETINT	0	JECCIS	0	VIR	0
POOL	0	RETMSG	1	IPINT2	0	CSMDS	0
DTRT	0	ANI	0	IPTRK	0	FXD	0
TMPRT	0	SRV	0	CTCF	1	FXJS	0
CODEC	0	TON	0	RERT	1	FXPT	0
PASS	0	NPI	0	DCANS	0	FXPS	0
IRL	0	L/T	0	RND	0	CPI	0
MTC	0	ECCIS	0	CLBK	0	E911	0



TC	0	ECCISTM	0	UALAW	2	RA_RT	0
TS	0	ECCISOB	0	MCTFAC	0		
CDCSPD	0	ECCISIB	0	RE	1		
DVRST	0	SPMET	0	PR	1		
RT	20						
RST	0	RSCT	0	IDRT	0	COT	0
HMT	0	ROCG	0	ECCISTD	0	SS7	0
TRCRST	0	RICG	0	MFCG2	0	NI2ID	0
TRSRST	0	STSENQ	0	OPCC	0	CLRF	0
T309LNK	0	MMNPASS	0	ICTCON	0	TRC	0
T309CON	0	DLTK	0	VRD	0	OID	0
LLCRST	0	CALN	0	INTD	0	PHG	0
VCM	0	NETINT	0	JECCIS	0	VIR	0
POOL	0	RETMSG	0	IPINT2	0	CSMDS	0
DTRT	0	ANI	0	IPTRK	0	FXD	0
TMPRT	0	SRV	0	CTCF	1	FXJS	0
CODEC	0	TON	0	RERT	1	FXPT	0
PASS	0	NPI	0	DCANS	0	FXPS	0
IRL	0	L/T	0	RND	0	CPI	0
MTC	0	ECCIS	0	CLBK	0	E911	0
TC	0	ECCISTM	0	UALAW	0	RA_RT	0
TS	0	ECCISOB	0	MCTFAC	0		
CDCSPD	0	ECCISIB	0	RE	1		
DVRST	0	SPMET	0	PR	0		



[IPX-R15_IP::LSFC]

* Service Feature Restriction Class List *

Starting Ending

Tenant 1 Tenant 1
SFI 1 SFI 221

SFC Attribute Settings

Table with columns: Tenant, Mode, SFI, and 15 attribute columns (0-14). Rows show settings for Tenant 1 across 13 days.



Day	14	0 0	0 0	0 0	0 0	0 0	0 0	0 0	0 0	0 0	0 0	0 0
Day	15	0 0	0 0	0 0	0 0	0 0	0 0	0 0	0 0	0 0	0 0	0 0
Day	16	0 0	0 0	0 0	0 0	0 0	0 0	0 0	0 0	0 0	0 0	0 0
Day	17	0 0	0 0	0 0	0 0	0 0	0 0	0 0	0 0	0 0	0 0	0 0
Day	18	0 0	0 0	0 0	0 0	0 0	0 0	0 0	0 0	0 0	0 0	0 0
Day	19	0 1	1 1	1 1	1 1	1 1	0 0	0 0	0 0	0 0	0 0	0 0
Day	20	0 0	0 0	0 0	0 0	0 0	0 0	0 0	0 0	0 0	0 0	0 0
Day	21	0 0	0 0	0 0	0 0	0 0	0 0	0 0	0 0	0 0	0 0	0 0
Day	22	0 0	0 0	0 0	0 0	0 0	0 0	0 0	0 0	0 0	0 0	0 0
Day	23	0 0	0 0	0 0	0 0	0 0	0 0	0 0	0 0	0 0	0 0	0 0
Day	24	0 0	0 0	0 0	0 0	0 0	0 0	0 0	0 0	0 0	0 0	0 0
Day	25	0 1	1 0	0 1	0 0	0 0	1 0	0 0	0 0	0 0	0 0	0 0
Day	26	0 1	1 0	0 1	0 0	0 0	1 0	0 0	0 0	0 0	0 0	0 0
Day	27	0 0	0 0	0 0	0 0	0 0	0 0	0 0	0 0	0 0	0 0	0 0
Day	28	0 0	0 0	0 0	0 0	0 0	0 0	0 0	0 0	0 0	0 0	0 0
Day	29	0 1	1 1	1 1	1 1	1 1	0 0	0 0	0 0	0 0	0 0	0 0
Day	30	0 1	1 1	1 1	1 1	1 1	0 0	0 0	0 0	0 0	0 0	0 0
Day	31	0 1	1 0	0 1	0 0	0 0	0 0	0 0	0 0	0 0	0 0	0 0
Day	32	0 0	0 0	0 0	0 0	0 0	0 0	0 0	0 0	0 0	0 0	0 0
Day	33	0 0	0 0	0 0	0 0	0 0	0 0	0 0	0 0	0 0	0 0	0 0
Day	34	0 0	0 0	0 0	0 0	0 0	0 0	0 0	0 0	0 0	0 0	0 0
Day	35	0 0	0 0	0 0	0 0	0 0	0 0	0 0	0 0	0 0	0 0	0 0
Day	36	0 0	0 0	0 0	0 0	0 0	0 0	0 0	0 0	0 0	0 0	0 0
Day	37	0 0	0 0	0 0	0 0	0 0	0 0	0 0	0 0	0 0	0 0	0 0



Day	38	0 0	0 0	0 0	0 0	0 0	0 0	0 0	0 0	0 0	0 0	0 0
Day	39	1 1	1 1	1 0	0 0	0 0	0 0	0 0	0 0	0 0	0 0	0 0
Day	40	0 0	0 0	0 0	0 0	0 0	0 0	0 0	0 0	0 0	0 0	0 0
Day	41	0 0	0 0	0 0	0 0	0 0	0 0	0 0	0 0	0 0	0 0	0 0
Day	42	0 0	0 0	0 0	0 0	0 0	0 0	0 0	0 0	0 0	0 0	0 0
Day	43	0 0	0 0	0 0	0 0	0 0	0 0	0 0	0 0	0 0	0 0	0 0
Day	44	0 1	1 1	1 1	0 0	0 0	0 1	0 0	0 0	0 0	0 0	0 0
Day	45	0 0	0 0	0 0	0 0	0 0	0 0	0 0	0 0	0 0	0 0	0 0
Day	46	0 0	0 0	0 0	0 0	0 0	0 0	0 0	0 0	0 0	0 0	0 0
Day	47	0 0	0 0	0 0	0 0	0 0	0 0	0 0	0 0	0 0	0 0	0 0
Day	48	0 0	0 0	0 0	0 0	0 0	0 0	0 0	0 0	0 0	0 0	0 0
Day	49	0 0	0 0	0 0	0 0	0 0	0 0	0 0	0 0	0 0	0 0	0 0
Day	50	0 0	0 0	0 0	0 0	0 0	0 0	0 0	0 0	0 0	0 0	0 0
Day	51	0 0	0 0	0 0	0 0	0 0	0 0	0 0	0 0	0 0	0 0	0 0
Day	52	0 1	1 1	1 1	0 0	0 0	0 1	0 0	0 0	0 0	0 0	0 0
Day	53	0 0	0 0	0 0	0 0	0 0	0 0	0 0	0 0	0 0	0 0	0 0
Day	54	0 0	0 0	0 0	0 0	0 0	0 0	0 0	0 0	0 0	0 0	0 0
Day	55	0 0	0 0	0 0	0 0	0 0	0 0	0 0	0 0	0 0	0 0	0 0
Day	56	0 0	0 0	0 0	0 0	0 0	0 0	0 0	0 0	0 0	0 0	0 0
Day	57	0 0	0 0	0 0	0 0	0 0	0 0	0 0	0 0	0 0	0 0	0 0
Day	58	0 0	0 0	0 0	0 0	0 0	0 0	0 0	0 0	0 0	0 0	0 0
Day	59	0 0	0 0	0 0	0 0	0 0	0 0	0 0	0 0	0 0	0 0	0 0
Day	60	0 0	0 0	0 0	0 0	0 0	0 0	0 0	0 0	0 0	0 0	0 0
Day	61	0 0	0 0	0 0	0 0	0 0	0 0	0 0	0 0	0 0	0 0	0 0



Day	62	0 0	0 0	0 0	0 0	0 0	0 0	0 0	0 0	0 0	0 0	0 0
Day	63	0 0	0 0	0 0	0 0	0 0	0 0	0 0	0 0	0 0	0 0	0 0
Day	64	0 0	0 0	0 0	0 0	0 0	0 0	0 0	0 0	0 0	0 0	0 0
Day	65	0 0	0 0	0 0	0 0	0 0	0 0	0 0	0 0	0 0	0 0	0 0
Day	66	0 0	0 0	0 0	0 0	0 0	0 0	0 0	0 0	0 0	0 0	0 0
Day	67	0 1	1 1	1 1	1 0	0 0	1 0	0 0	0 0	0 0	0 0	0 0
Day	68	0 1	1 1	1 1	0 0	0 0	1 0	0 0	0 0	0 0	0 0	0 0
Day	69	0 0	0 0	0 0	0 0	0 0	0 0	0 0	0 0	0 0	0 0	0 0
Day	70	0 0	0 0	0 0	0 0	0 0	0 0	0 0	0 0	0 0	0 0	0 0
Day	71	0 0	0 0	0 0	0 0	0 0	0 0	0 0	0 0	0 0	0 0	0 0
Day	72	0 0	0 0	0 0	0 0	0 0	0 0	0 0	0 0	0 0	0 0	0 0
Day	73	0 0	0 0	0 0	0 0	0 0	0 0	0 0	0 0	0 0	0 0	0 0
Day	74	0 1	1 1	1 1	1 1	1 1	0 0	0 0	0 0	0 0	0 0	0 0
Day	75	0 1	1 0	0 0	0 0	0 0	0 0	0 0	0 0	0 0	0 0	0 0
Day	76	0 0	0 0	0 0	0 0	0 0	0 0	0 0	0 0	0 0	0 0	0 0
Day	77	0 0	0 0	0 0	0 0	0 0	0 0	0 0	0 0	0 0	0 0	0 0
Day	78	0 0	0 0	0 0	0 0	0 0	0 0	0 0	0 0	0 0	0 0	0 0
Day	79	0 0	0 0	0 0	0 0	0 0	0 0	0 0	0 0	0 0	0 0	0 0
Day	80	0 0	1 0	0 0	0 0	0 0	0 0	0 0	0 0	0 0	0 0	0 0
Day	81	0 0	0 0	0 0	0 0	0 0	0 0	0 0	0 0	0 0	0 0	0 0
Day	82	1 1	1 1	1 1	1 0	0 0	0 0	0 0	0 0	0 0	0 0	0 0
Day	83	0 0	0 0	0 0	0 0	0 0	0 0	0 0	0 0	0 0	0 0	0 0
Day	84	0 0	0 0	0 0	0 0	0 0	0 0	0 0	0 0	0 0	0 0	0 0
Day	85	0 0	0 0	0 0	0 0	0 0	0 0	0 0	0 0	0 0	0 0	0 0



Day	86	0 0	0 0	0 0	0 0	0 0	0 0	0 0	0 0	0 0	0 0	0 0
Day	87	0 0	0 0	0 0	0 0	0 0	0 0	0 0	0 0	0 0	0 0	0 0
Day	88	0 0	0 0	0 0	0 0	0 0	0 0	0 0	0 0	0 0	0 0	0 0
Day	89	0 0	0 0	0 0	0 0	0 0	0 0	0 0	0 0	0 0	0 0	0 0
Day	90	0 0	0 0	0 0	0 0	0 0	0 0	0 0	0 0	0 0	0 0	0 0
Day	91	0 0	0 0	0 0	0 0	0 0	0 0	0 0	0 0	0 0	0 0	0 0
Day	92	0 0	0 0	0 0	0 0	0 0	0 0	0 0	0 0	0 0	0 0	0 0
Day	93	0 0	0 0	0 0	0 0	0 0	0 0	0 0	0 0	0 0	0 0	0 0
Day	94	0 0	0 0	0 0	0 0	0 0	0 0	0 0	0 0	0 0	0 0	0 0
Day	95	0 0	0 0	0 0	0 0	0 0	0 0	0 0	0 0	0 0	0 0	0 0
Day	96	0 0	0 0	0 0	0 0	0 0	0 0	0 0	0 0	0 0	0 0	0 0
Day	97	0 1	1 0	0 0	0 0	0 0	0 0	0 0	0 0	0 0	0 0	0 0
Day	98	0 0	0 0	0 0	0 0	0 0	0 0	0 0	0 0	0 0	0 0	0 0
Day	99	0 0	0 0	0 0	0 0	0 0	0 0	0 0	0 0	0 0	0 0	0 0
Day	100	0 0	0 0	0 0	0 0	0 0	0 0	0 0	0 0	0 0	0 0	0 0
Day	101	0 0	0 0	0 0	0 0	0 0	0 0	0 0	0 0	0 0	0 0	0 0
Day	102	0 0	0 0	0 0	0 0	0 0	0 0	0 0	0 0	0 0	0 0	0 0
Day	103	0 0	0 0	0 1	0 0	0 0	0 0	0 0	0 0	0 0	0 0	0 0
Day	104	0 1	1 0	0 1	0 0	0 0	0 1	0 0	0 0	0 0	0 0	0 0
Day	105	0 0	0 0	0 0	0 0	0 0	0 0	0 0	0 0	0 0	0 0	0 0
Day	106	0 0	0 0	0 0	0 0	0 0	0 0	0 0	0 0	0 0	0 0	0 0
Day	107	0 0	0 0	0 0	0 0	0 0	0 0	0 0	0 0	0 0	0 0	0 0
Day	108	0 0	0 0	0 0	0 0	0 0	0 0	0 0	0 0	0 0	0 0	0 0
Day	109	0 1	1 0	0 0	0 0	0 0	0 0	0 0	0 0	0 0	0 0	0 0



Day	110	0 0	0 0	0 0	0 0	0 0	0 0	0 0	0 0	0 0	0 0	0 0
Day	111	0 0	0 0	0 0	0 0	0 0	0 0	0 0	0 0	0 0	0 0	0 0
Day	112	0 0	0 0	0 0	0 0	0 0	0 0	0 0	0 0	0 0	0 0	0 0
Day	113	0 0	0 0	0 0	0 0	0 0	0 0	0 0	0 0	0 0	0 0	0 0
Day	114	0 1	1 0	0 0	0 0	0 0	0 0	0 0	0 0	0 0	0 0	0 0
Day	115	0 0	0 0	0 0	0 0	0 0	0 0	0 0	0 0	0 0	0 0	0 0
Day	116	0 0	0 0	0 0	0 0	0 0	0 0	0 0	0 0	0 0	0 0	0 0
Day	117	0 0	0 0	0 0	0 0	0 0	0 0	0 0	0 0	0 0	0 0	0 0
Day	118	0 0	0 0	0 0	0 0	0 0	0 0	0 0	0 0	0 0	0 0	0 0
Day	119	0 0	0 0	0 0	0 0	0 0	0 0	0 0	0 0	0 0	0 0	0 0
Day	120	0 0	0 0	0 0	0 0	0 0	0 0	0 0	0 0	0 0	0 0	0 0
Day	121	0 0	0 0	0 0	0 0	0 0	0 0	0 0	0 0	0 0	0 0	0 0
Day	122	0 0	0 0	0 0	0 0	0 0	0 0	0 0	0 0	0 0	0 0	0 0
Day	123	0 0	0 0	0 0	0 0	0 0	0 0	0 0	0 0	0 0	0 0	0 0
Day	124	0 0	0 0	0 0	0 0	0 0	0 0	0 0	0 0	0 0	0 0	0 0
Day	125	0 0	0 0	0 0	0 0	0 0	0 0	0 0	0 0	0 0	0 0	0 0
Day	126	0 0	0 0	0 0	0 0	0 0	0 0	0 0	0 0	0 0	0 0	0 0
Day	127	0 0	0 0	0 0	0 0	0 0	0 0	0 0	0 0	0 0	0 0	0 0
Day	128	0 0	0 0	0 0	0 0	0 0	0 0	0 0	0 0	0 0	0 0	0 0
Day	129	0 0	0 0	0 0	0 0	0 0	0 0	0 0	0 0	0 0	0 0	0 0
Day	130	0 0	0 0	0 0	0 0	0 0	0 0	0 0	0 0	0 0	0 0	0 0
Day	131	0 1	0 0	0 0	0 0	0 0	0 0	0 0	0 0	0 0	0 0	0 0
Day	132	0 0	0 0	0 0	0 0	0 0	0 0	0 0	0 0	0 0	0 0	0 0
Day	133	0 0	0 0	0 0	0 0	0 0	0 0	0 0	0 0	0 0	0 0	0 0



Day	134	0 0	0 0	0 0	0 0	0 0	0 0	0 0	0 0	0 0	0 0	0 0
Day	135	0 0	0 0	0 0	0 0	0 0	0 0	0 0	0 0	0 0	0 0	0 0
Day	136	0 0	0 0	0 0	0 0	0 0	0 0	0 0	0 0	0 0	0 0	0 0
Day	137	0 0	0 0	0 0	0 0	0 0	0 0	0 0	0 0	0 0	0 0	0 0
Day	138	0 0	1 0	0 0	0 0	0 0	0 0	0 0	0 0	0 0	0 0	0 0
Day	139	0 0	0 0	0 0	0 0	0 0	0 0	0 0	0 0	0 0	0 0	0 0
Day	140	0 0	0 0	0 0	0 0	0 0	0 0	0 0	0 0	0 0	0 0	0 0
Day	141	0 0	0 0	0 0	0 0	0 0	0 0	0 0	0 0	0 0	0 0	0 0
Day	142	0 0	0 0	0 0	0 0	0 0	0 0	0 0	0 0	0 0	0 0	0 0
Day	143	0 0	0 0	0 0	0 0	0 0	0 0	0 0	0 0	0 0	0 0	0 0
Day	144	0 0	0 0	0 0	0 0	0 0	0 0	0 0	0 0	0 0	0 0	0 0
Day	145	0 0	0 0	0 0	0 0	0 0	0 0	0 0	0 0	0 0	0 0	0 0
Day	146	0 1	1 0	0 0	0 0	0 0	0 0	0 0	0 0	0 0	0 0	0 0
Day	147	0 0	0 0	0 0	0 0	0 0	0 0	0 0	0 0	0 0	0 0	0 0
Day	148	0 0	0 0	0 0	0 0	0 0	0 0	0 0	0 0	0 0	0 0	0 0
Day	149	0 0	0 0	0 0	0 0	0 0	0 0	0 0	0 0	0 0	0 0	0 0
Day	150	0 0	0 0	0 0	0 0	0 0	0 0	0 0	0 0	0 0	0 0	0 0
Day	151	0 0	0 0	0 0	0 0	0 0	0 0	0 0	0 0	0 0	0 0	0 0
Day	152	0 0	0 0	0 0	0 0	0 0	0 0	0 0	0 0	0 0	0 0	0 0
Day	153	0 0	0 0	0 0	0 0	0 0	0 0	0 0	0 0	0 0	0 0	0 0
Day	154	0 0	0 0	0 0	0 0	0 0	0 0	0 0	0 0	0 0	0 0	0 0
Day	155	0 0	0 0	0 0	0 0	0 0	0 0	0 0	0 0	0 0	0 0	0 0
Day	156	0 0	0 0	0 0	0 0	0 0	0 0	0 0	0 0	0 0	0 0	0 0
Day	157	0 0	0 0	0 0	0 0	0 0	0 0	0 0	0 0	0 0	0 0	0 0



Day	158	0 0	0 0	0 0	0 0	0 0	0 0	0 0	0 0	0 0	0 0	0 0
Day	159	0 0	0 0	0 0	0 0	0 0	0 0	0 0	0 0	0 0	0 0	0 0
Day	160	0 0	0 0	0 0	0 0	0 0	0 0	0 0	0 0	0 0	0 0	0 0
Day	161	0 0	0 0	0 0	0 0	0 0	0 0	0 0	0 0	0 0	0 0	0 0
Day	162	0 0	0 0	0 0	0 0	0 0	0 0	0 0	0 0	0 0	0 0	0 0
Day	163	0 0	0 0	0 0	0 0	0 0	0 0	0 0	0 0	0 0	0 0	0 0
Day	164	0 0	0 0	0 0	0 0	0 0	0 0	0 0	0 0	0 0	0 0	0 0
Day	165	0 1	1 0	0 0	0 0	0 0	0 0	0 0	0 0	0 0	0 0	0 0
Day	166	0 0	0 0	0 0	0 0	0 0	0 0	0 0	0 0	0 0	0 0	0 0
Day	167	0 0	0 0	0 0	0 0	0 0	0 0	0 0	0 0	0 0	0 0	0 0
Day	168	0 0	0 0	0 0	0 0	0 0	0 0	0 0	0 0	0 0	0 0	0 0
Day	169	0 0	0 0	0 0	0 0	0 0	0 0	0 0	0 0	0 0	0 0	0 0
Day	170	0 0	0 0	0 0	0 0	0 0	0 0	0 0	0 0	0 0	0 0	0 0
Day	171	0 0	0 0	0 0	0 0	0 0	0 0	0 0	0 0	0 0	0 0	0 0
Day	172	0 0	0 0	0 0	0 0	0 0	0 0	0 0	0 0	0 0	0 0	0 0
Day	173	0 0	0 0	0 0	0 0	0 0	0 0	0 0	0 0	0 0	0 0	0 0
Day	174	0 0	1 0	0 0	0 0	0 0	0 0	0 0	0 0	0 0	0 0	0 0
Day	175	0 1	1 0	0 1	0 0	0 0	0 0	0 0	0 0	0 0	0 0	0 0
Day	176	0 0	0 0	0 0	0 0	0 0	0 0	0 0	0 0	0 0	0 0	0 0
Day	177	0 0	0 0	0 0	0 0	0 0	0 0	0 0	0 0	0 0	0 0	0 0
Day	178	0 0	0 0	0 0	0 0	0 0	0 0	0 0	0 0	0 0	0 0	0 0
Day	179	0 0	0 0	0 0	0 0	0 0	0 0	0 0	0 0	0 0	0 0	0 0
Day	180	0 0	0 0	0 0	0 0	0 0	0 0	0 0	0 0	0 0	0 0	0 0
Day	181	0 0	0 0	0 0	0 0	0 0	0 0	0 0	0 0	0 0	0 0	0 0



Day	182	0 0	0 0	0 0	0 0	0 0	0 0	0 0	0 0	0 0	0 0	0 0
Day	183	0 0	0 0	0 0	0 0	0 0	0 0	0 0	0 0	0 0	0 0	0 0
Day	184	0 0	0 0	0 0	0 0	0 0	0 0	0 0	0 0	0 0	0 0	0 0
Day	185	0 0	0 0	0 0	0 0	0 0	0 0	0 0	0 0	0 0	0 0	0 0
Day	186	0 0	0 0	0 0	0 0	0 0	0 0	0 0	0 0	0 0	0 0	0 0
Day	187	0 0	0 0	0 0	0 0	0 0	0 0	0 0	0 0	0 0	0 0	0 0
Day	188	0 1	1 0	0 0	0 0	0 0	0 0	0 0	0 0	0 0	0 0	0 0
Day	189	0 0	0 0	0 0	0 0	0 0	0 0	0 0	0 0	0 0	0 0	0 0
Day	190	0 0	0 0	0 0	0 0	0 0	0 0	0 0	0 0	0 0	0 0	0 0
Day	191	0 0	0 0	0 0	0 0	0 0	0 0	0 0	0 0	0 0	0 0	0 0
Day	192	0 0	0 0	0 0	0 0	0 0	0 0	0 0	0 0	0 0	0 0	0 0
Day	193	0 0	0 0	0 0	0 0	0 0	0 0	0 0	0 0	0 0	0 0	0 0
Day	194	0 0	0 0	0 0	0 0	0 0	0 0	0 0	0 0	0 0	0 0	0 0
Day	195	0 0	0 0	0 0	0 0	0 0	0 0	0 0	0 0	0 0	0 0	0 0
Day	196	0 0	0 0	0 0	0 0	0 0	0 0	0 0	0 0	0 0	0 0	0 0
Day	197	0 0	0 0	0 0	0 0	0 0	0 0	0 0	0 0	0 0	0 0	0 0
Day	198	0 0	0 0	0 0	0 0	0 0	0 0	0 0	0 0	0 0	0 0	0 0
Day	199	0 0	0 0	0 0	0 0	0 0	0 0	0 0	0 0	0 0	0 0	0 0
Day	200	0 0	0 0	0 0	0 0	0 0	0 0	0 0	0 0	0 0	0 0	0 0
Day	201	0 0	0 0	0 0	0 0	0 0	0 0	0 0	0 0	0 0	0 0	0 0
Day	202	0 1	1 0	0 0	0 0	0 0	0 0	0 0	0 0	0 0	0 0	0 0
Day	203	0 0	0 0	0 0	0 0	0 0	0 0	0 0	0 0	0 0	0 0	0 0
Day	204	0 0	0 0	0 0	0 0	0 0	0 0	0 0	0 0	0 0	0 0	0 0
Day	205	0 0	0 0	0 0	0 0	0 0	0 0	0 0	0 0	0 0	0 0	0 0



Day	206	0 0	0 0	0 0	0 0	0 0	0 0	0 0	0 0	0 0	0 0	0 0
Day	207	0 0	0 0	0 0	0 0	0 0	0 0	0 0	0 0	0 0	0 0	0 0
Day	208	0 0	0 0	0 0	0 0	0 0	0 0	0 0	0 0	0 0	0 0	0 0
Day	209	0 0	0 0	0 0	0 0	0 0	0 0	0 0	0 0	0 0	0 0	0 0
Day	210	0 0	0 0	0 0	0 0	0 0	0 0	0 0	0 0	0 0	0 0	0 0
Day	211	0 0	0 0	0 0	0 0	0 0	0 0	0 0	0 0	0 0	0 0	0 0
Day	212	0 0	0 0	0 0	0 0	0 0	0 0	0 0	0 0	0 0	0 0	0 0
Day	213	0 0	0 0	0 0	0 0	0 0	0 0	0 0	0 0	0 0	0 0	0 0
Day	214	0 0	0 0	0 0	0 0	0 0	0 0	0 0	0 0	0 0	0 0	0 0
Day	215	0 0	0 0	0 0	0 0	0 0	0 0	0 0	0 0	0 0	0 0	0 0
Day	216	0 0	0 0	0 0	0 0	0 0	0 0	0 0	0 0	0 0	0 0	0 0
Day	217	0 0	0 0	0 0	0 0	0 0	0 0	0 0	0 0	0 0	0 0	0 0
Day	218	0 0	0 0	0 0	0 0	0 0	0 0	0 0	0 0	0 0	0 0	0 0
Day	219	0 0	0 0	0 0	0 0	0 0	0 0	0 0	0 0	0 0	0 0	0 0
Day	220	0 0	0 0	0 0	0 0	0 0	0 0	0 0	0 0	0 0	0 0	0 0
Day	221	0 0	0 0	0 0	0 0	0 0	0 0	0 0	0 0	0 0	0 0	0 0

[IPX-R15_IP::LSPA]

July 27, 2005

* Special Access Code List *

Starting		Ending	
Tenant	1	Tenant	1
Access Code	1	Access Code	#
ction Index	Normal	ction Index	Busy



TN	ACC	CI	SRV					
1	1	Norma	STN					
1	22	Norma	OGC	RT	:	22		
1	23	Norma	OGC	RT	:	23		
1	3	Norma	LCR	RT	:	19	2ndDT :1	AH :0 SUB:0
1	4	Norma	STN					
1	8	Norma	LCR	RT	:	31	2ndDT :1	AH :0 SUB:0
1	*1	Norma	OGC	RT	:	1		
1	*2	Norma	LCR	RT	:	31	2ndDT :1	AH :0 SUB:0
1	*3	Norma	LCR	RT	:	31	2ndDT :1	AH :0 SUB:0
1	*4	Norma	LCR	RT	:	31	2ndDT :1	AH :0 SUB:0
1	*5	Norma	LCR	RT	:	31	2ndDT :1	AH :0 SUB:0
1	*6	Norma	LCR	RT	:	31	2ndDT :1	AH :0 SUB:0
1	*7	Norma	LCR	RT	:	31	2ndDT :1	AH :0 SUB:0
1	*8	Norma	LCR	RT	:	31	2ndDT :1	AH :0 SUB:0
1	*9	Norma	LCR	RT	:	31	2ndDT :1	AH :0 SUB:0
1	**	Norma	SSC	SID	:	14		
1	1	Hooki	STN					
1	3	Hooki	LCR	RT	:	19	2ndDT :0	AH :0 SUB:0
1	4	Hooki	STN					
1	8	Hooki	LCR	RT	:	31	2ndDT :1	AH :0 SUB:0



1	*3	Hooki	LCR	RT	: 31	2ndDT	:1	AH	:0	SUB:0
1	*4	Hooki	LCR	RT	: 31	2ndDT	:1	AH	:0	SUB:0
1	*5	Hooki	LCR	RT	: 31	2ndDT	:1	AH	:0	SUB:0
1	*6	Hooki	LCR	RT	: 31	2ndDT	:1	AH	:0	SUB:0
1	*7	Hooki	LCR	RT	: 31	2ndDT	:1	AH	:0	SUB:0
1	*8	Hooki	LCR	RT	: 31	2ndDT	:1	AH	:0	SUB:0
1	*9	Hooki	LCR	RT	: 31	2ndDT	:1	AH	:0	SUB:0
1	1	Busy	STN							
1	22	Busy	OGC	RT	: 22					
1	3	Busy	LCR	RT	: 19	2ndDT	:0	AH	:0	SUB:0
1	*3	Busy	LCR	RT	: 31	2ndDT	:1	AH	:0	SUB:0
1	*6	Busy	LCR	RT	: 31	2ndDT	:1	AH	:0	SUB:0
1	*7	Busy	LCR	RT	: 31	2ndDT	:1	AH	:0	SUB:0
1	*8	Busy	LCR	RT	: 31	2ndDT	:1	AH	:0	SUB:0
1	*9	Busy	LCR	RT	: 31	2ndDT	:1	AH	:0	SUB:0

[IPX-R15_IP::LOPR]

July 27, 2005

* Outgoing Pattern Routing Data List *

TDPTN OPR RA Orde RA End Route SKIP PNL OVFT PRSC



0 3 0 0 19 0 0 0 0

[IPX-R15_IP::LFRS]

July 27, 2005

* Flexible Route Selection List *

Tenant	Route	Number	Pattern	OPR
1	19	3		3



Configuring Cisco CallManager

Cisco CallManager Configuration

[Cor](#)

[Back to](#)

Cisco CallManager: CM_4-1 (CM_4-1) on 172.20.16.250
CTI ID: 1

Status: Ready

Copy

Update

Delete

Reset Devices

Server Information

Cisco CallManager Name*

Description

Auto-registration Information

Starting Directory Number*

Ending Directory Number*

Partition

External Phone Number Mask

Auto-registration Disabled on this Cisco CallManager

Cisco CallManager TCP Port Settings for this Server

Ethernet Phone Port*

Digital Port*

Analog Port*

MGCP Listen Port*

MGCP Keep-alive Port*

* indicates required item.



Route Pattern Configuration

[Add a New Route Pattern](#)
[Back to Find/List Route Patterns](#)

Route Pattern: 405X

Status: Ready

Note: Any update to this Route Pattern automatically resets the associated gateway or Route List

Pattern Definition

Route Pattern*	<input type="text" value="405X"/>
Partition	<input type="text" value="CiscoPartition"/>
Description	<input type="text"/>
Numbering Plan*	<input type="text" value="North American Numbering Plan"/>
Route Filter	<input type="text" value="< None >"/>
MLPP Precedence	<input type="text" value="Default"/>
Gateway or Route List*	<input type="text" value="S1/DS1-0@2611XM-B"/> (Edit)
Route Option	<input checked="" type="radio"/> Route this pattern <input type="radio"/> Block this pattern <input type="text" value="— Not Selected —"/>
Call Classification*	<input type="text" value="OffNet"/> <input type="checkbox"/> Allow Device Override
<input checked="" type="checkbox"/> Provide Outside Dial Tone	<input type="checkbox"/> Allow Overlap Sending <input type="checkbox"/> Urgent Priority
<input type="checkbox"/> Require Forced Authorization Code	
Authorization Level	<input type="text" value="0"/>
<input type="checkbox"/> Require Client Matter Code	

Calling Party Transformations

<input type="checkbox"/> Use Calling Party's External Phone Number Mask	
Calling Party Transform Mask	<input type="text"/>
Prefix Digits (Outgoing Calls)	<input type="text"/>
Calling Line ID Presentation	<input type="text" value="Default"/>
Calling Name Presentation	<input type="text" value="Default"/>

Connected Party Transformations

Connected Line ID Presentation	<input type="text" value="Default"/>
Connected Name Presentation	<input type="text" value="Default"/>

Called Party Transformations

Discard Digits	<input type="text" value="< None >"/>
Called Party Transform Mask	<input type="text"/>
Prefix Digits (Outgoing Calls)	<input type="text"/>

ISDN Network-Specific Facilities Information Element

Carrier Identification Code	<input type="text"/>				
Network Service Protocol	<input type="text" value="— Not Selected —"/>				
Network Service	<input type="text" value="— Not Selected —"/>	Service Parameter Name	<input type="text" value="< Not Exist >"/>	Service Parameter Value	<input type="text"/>

* indicates required item.



Service Parameters Configuration

[Select Another Server/Service Parameters for all servers](#)

Current Server : 172.20.16.250

Current Service: Cisco CallManager



Status: Ready

All parameters apply to the current server except those in the Clusterwide group(s)

CCM Call Throttling

Parameter Name	Parameter Value	Suggested Value
Code Yellow Entry Latency (msec)*	<input type="text" value="20"/>	20
Code Yellow Exit Latency Calculation (%)*	<input type="text" value="40"/>	40
Code Yellow Duration (min)*	<input type="text" value="99999"/>	99999
Max Events Allowed*	<input type="text" value="2000"/>	2000
System Throttle Sample Size*	<input type="text" value="10"/>	10

Route Plan

Parameter Name	Parameter Value	Suggested Value
Dial Plan Path*	<input type="text" value="C:\Program Files\Cisco\DialPlan\"/>	C:\Program Files\Cisco\DialPlan\



System

Parameter Name	Parameter Value	Suggested Value
----------------	-----------------	-----------------

CDR Enabled Flag*	<input type="text" value="False"/>	False
-------------------	------------------------------------	-------

CDR Log Calls with Zero Duration Flag*	<input type="text" value="False"/>	False
--	------------------------------------	-------

Digit Analysis Complexity*	<input type="text" value="StandardAnalysis"/>	StandardAnalysis
----------------------------	---	------------------

Database Debounce Timer (sec)*	<input type="text" value="0"/>	0
--------------------------------	--------------------------------	---

Maximum Phone Fallback Queue Depth*	<input type="text" value="10"/>	10
-------------------------------------	---------------------------------	----

Maximum Number of Registered Devices*	<input type="text" value="5000"/>	5000
---------------------------------------	-----------------------------------	------

Enable TCP KeepAlives For SSAPI Interface*	<input type="text" value="False"/>	False
--	------------------------------------	-------

ProgLogs Trace File Path*	<input type="text" value="C:\Program Files\Cisco\Trace\ProgLogs\"/>	C:\Program Files\Cisco\Trace\ProgLogs\
---------------------------	---	--

Some parameters in this group are hidden, click on Advanced button to see hidden parameters

SDL Trace

Parameter Name	Parameter Value	Suggested Value
----------------	-----------------	-----------------

SDL Trace Data Flags*	<input type="text" value="0x00000111"/>	0x00000111
-----------------------	---	------------

SDL Trace Flush Immediately*	<input type="text" value="True"/>	True
------------------------------	-----------------------------------	------

SDL Trace Data Size*	<input type="text" value="0"/>	0
----------------------	--------------------------------	---

SDL Trace Flag*	<input type="text" value="True"/>	True
-----------------	-----------------------------------	------

SDL TraceType Flags*	<input type="text" value="0x8000EB75"/>	0x8000EB15
----------------------	---	------------

SDL XML Trace Flag*	<input type="text" value="False"/>	False
---------------------	------------------------------------	-------



Clusterwide Parameters (Device - Phone)

Parameter Name	Parameter Value	Suggested Value
Always Use Prime Line*	<input type="text" value="True"/>	False
Always Use Prime Line for Voice Message*	<input type="text" value="False"/>	False
Builtin Bridge Enable*	<input type="text" value="Off"/>	Off
Auto Answer Timer (sec)*	<input type="text" value="1"/>	1
Extension Display on Cisco IP Phone Model 7910*	<input type="text" value="False"/>	False
Alternate Idle Phone Auto Answer Behavior*	<input type="text" value="False"/>	False
Hold Type*	<input type="text" value="False"/>	False
Line State Update Enabled*	<input type="text" value="True"/>	True
Off-hook to First Digit Timer (msec)*	<input type="text" value="15000"/>	15000
Override Auto Answer If Speaker Is Disabled*	<input type="text" value="True"/>	True
Out-of-Bandwidth Text*	<input type="text" value="Not Enough Bandwidth"/>	Not Enough Bandwidth
AAR Network Congestion Rerouting Text*	<input type="text" value="Network Congestion. Rerouting."/>	Network Congestion. Rerouting.
Ring Setting of Busy Station Policy*	<input type="text" value="Only Apply Ring Setting of Busy Station When Incoming Call Arrives"/>	Only Apply Ring Setting of Busy Station When Incoming Call Arrives
Transfer On-hook Enabled*	<input type="text" value="False"/>	False



Ring Setting of Busy Station* Beep Only

Ring Setting of Idle Station* Ring

Privacy Setting* True

Speed Dial Await Further Digits* False

Clusterwide Parameters (Device - PRI and MGCP Gateway)

Parameter Name	Parameter Value	Suggested Value
Calling Party Number Screening Indicator*	<input type="text" value="CallManager sets the screening indicator value - Default setting"/>	CallManager sets the screening indicator value - Default setting

Clear Calls Flag When Datalink Is Down* True

Device Status Poll Interval (msec)* 3000

Disable Alerting Progress Indicator* False

Discard Non Inband Progress in Overlap Sending* False

Disable Resume from Shared-line MGCP FXS Port* True

DTMF Silence Tone Flag* False

Enable Sending PRI NI2 Service Message* False



Device Status Poll Interval (msec)*	<input type="text" value="3000"/>	3000
Disable Alerting Progress Indicator*	<input type="text" value="False"/>	False
Discard Non Inband Progress in Overlap Sending*	<input type="text" value="False"/>	False
Disable Resume from Shared-line MGCP FXS Port*	<input type="text" value="True"/>	True
DTMF Silence Tone Flag*	<input type="text" value="False"/>	False
Enable Sending PRI NI2 Service Message*	<input type="text" value="False"/>	False
Flash Hook Duration (msec)*	<input type="text" value="500"/>	500
Gateway KeepAlive Timer (sec)*	<input type="text" value="25"/>	25
Gateway Poll Timer (sec)*	<input type="text" value="10"/>	10
Location In PRI Progress Indicator IE (User Side Only)*	<input type="text" value="Use the Network Side PRI progress indicator IE"/>	Use the Network Side PRI progress indicator IE
Matching Calling Party with Attendant Flag*	<input type="text" value="False"/>	False
MGCP Database Query Delay Timer (msec)*	<input type="text" value="1000"/>	1000



MGCP Response Timer (sec)*	<input type="text" value="30"/>	30
MGCP Timer (sec)*	<input type="text" value="3"/>	3
Numbering Plan Info*	<input type="text" value="1"/>	1
Overlap Receiving Flag for PRI*	<input type="text" value="True"/>	True
Port Release Timer (sec)*	<input type="text" value="0"/>	0
SMDI Call Delay Timer (sec)*	<input type="text" value="0"/>	0
Retain Media on Disconnect with PI for Active Call*	<input type="text" value="False"/>	False
Stable in State 4 Flag*	<input type="text" value="False"/>	False
Suppress Out-of-Channels Alarms*	<input type="text" value="True"/>	True
I-Frame Timer (msec)*	<input type="text" value="2000"/>	2000
User-to-User IE Status*	<input type="text" value="True"/>	False



Clusterwide Parameters (Feature - Forward)

Parameter Name	Parameter Value	Suggested Value
Forward Maximum Hop Count*	<input type="text" value="12"/>	12
Forward No Answer Timer (sec)*	<input type="text" value="12"/>	12
Max Forward Hops to DN*	<input type="text" value="12"/>	12
Retain Forward Information*	<input type="text" value="True"/>	False
Forward By Reroute Enabled*	<input type="text" value="False"/>	False
Transform Forward by Reroute Destination*	<input type="text" value="True"/>	True
Always Forward Switch Voice Mail Calls*	<input type="text" value="True"/>	True
Forward By Reroute T1 Timer (sec)*	<input type="text" value="10"/>	10
Include Original Called Info for Q.SIG Call Diversions*	<input type="text" value="Always"/>	Only after the first diversion

Clusterwide Parameters (Feature - Multilevel Precedence and Preemption)

Parameter Name	Parameter Value	Suggested Value
Locations-based MLPP Enable*	<input type="text" value="False"/>	False
Executive Override Call Preemptable*	<input type="text" value="False"/>	False



Clusterwide Parameters (Feature - Path Replacement)

Parameter Name	Parameter Value	Suggested Value
Path Replacement Enabled*	<input type="text" value="True"/>	False
Path Replacement on Tromboned Calls*	<input type="text" value="True"/>	True
Start Path Replacement Minimum Delay Time (sec)*	<input type="text" value="0"/>	0
Start Path Replacement Maximum Delay Time (sec)*	<input type="text" value="10"/>	0
Path Replacement T1 Timer (sec)*	<input type="text" value="30"/>	30
Path Replacement T2 Timer (sec)*	<input type="text" value="15"/>	15
Path Replacement PINX ID	<input type="text"/>	
Path Replacement Calling Search Space	<input type="text" value="IPphones"/>	



Clusterwide Parameters (Feature - Call Back)

Parameter Name	Parameter Value	Suggested Value
Call Back Enabled Flag*	<input type="text" value="True"/>	True
Call Back Notification Audio File Name*	<input type="text" value="CallBack.raw"/>	CallBack.raw
Connection Proposal Type*	<input type="text" value="Connection Retention"/>	Connection Retention
Connection Response Type*	<input type="text" value="Default to Connection Retention"/>	Default to Connection Retention
Call Back Request Protection T1 Timer (sec)*	<input type="text" value="10"/>	10
Call Back Recall T3 Timer (sec)*	<input type="text" value="20"/>	20
Call Back Calling Search Space	<input type="text" value="IPphones"/>	



CM4.1-E1 Gateway Configuration

Gateway Configuration

[Back to Find/List Gateways](#)

Product: Cisco 26XX

Protocol: MGCP

MGCP : 2611XM-B

Status: Ready

Update

Delete

Reset Gateway

Domain Name*	<input type="text" value="2611XM-B"/>
Description	<input type="text" value="2611XM-B"/>
Cisco CallManager Group*	<input type="text" value="Default"/>

Installed Voice Interface Cards

Endpoint Identifiers

Module in slot 0	<input type="text" value="< None >"/>	
Module in slot 1	<input type="text" value="NM-HDV2-1PORT-E1"/>	
Subunit 0	<input type="text" value="< None >"/>	Begin Port <input type="text" value="0"/>
Subunit 1	<input type="text" value="NM-HDV2-ONBOARD-E1"/>	Begin Port <input type="text" value="0"/> <small>(1/0) </small>

Product Specific Configuration

Switchback Timing*	<input type="text" value="Graceful"/>
Switchback uptime-delay (min)	<input type="text" value="10"/>
Switchback schedule (hh:mm)	<input type="text" value="12:00"/>



Gateway Configuration

[Back to MGCP Configuration](#)

[Back to Find/List Gateways](#)

[Dependency Records](#)

Product : Cisco 26XX
Gateway : S1/DS1-0@2611XM-B
Device Protocol: Digital Access PRI
Registration: Registered with Cisco CallManager 172.20.16.250
IP Address: [172.20.16.56](#)

Status: Ready

Device Information

End-Point Name*	<input type="text" value="S1/DS1-0@2611XM-B"/>
Description	<input type="text" value="S1/DS1-0@2611XM-B"/>
Device Pool*	<input type="text" value="Default"/>
Call Classification*	<input type="text" value="Use System Default"/>
Network Locale	<input type="text" value="United States"/>
Signal Packet Capture Mode	<input type="text" value="None"/>
Packet Capture Duration	<input type="text" value="60"/>
Media Resource Group List	<input type="text" value="< None >"/>
Location	<input type="text" value="< None >"/>
AAR Group	<input type="text" value="< None >"/>
Load Information	<input type="text"/>
V150 (subset)	<input type="checkbox"/>

Multilevel Precedence and Preemption (MLPP) Information

MLPP Domain (e.g., "0000FF")	<input type="text"/>
MLPP Indication	Not available on this device
MLPP Preemption	Not available on this device



Interface Information

PRI Protocol Type*	PRI QSIG E1
Protocol Side*	Network
Channel Selection Order*	Bottom Up
Channel IE Type*	Continuous Number
PCM Type*	µ-law
Delay for first restart (1/8 sec ticks)	32
Delay between restarts (1/8 sec ticks)	4
<input checked="" type="checkbox"/> Inhibit restarts at PRI initialization	
<input checked="" type="checkbox"/> Enable status poll	

Call Routing Information

Inbound Calls

Significant Digits*	All
Calling Search Space	IPphones
AAR Calling Search Space	< None >
Prefix DN	

Outbound Calls

Calling Line ID Presentation*	Default
Calling Party Selection*	Originator
Called party IE number type unknown*	Cisco CallManager
Calling party IE number type unknown*	Cisco CallManager
Called Numbering Plan*	Cisco CallManager
Calling Numbering Plan*	Cisco CallManager
Number of digits to strip*	0
Caller ID DN	
SMDI Base Port*	0



PRI Protocol Type Specific Information

- Display IE Delivery
- Redirecting Number IE Delivery - Outbound
- Redirecting Number IE Delivery - Inbound
- Send Extra Leading Character In DisplayIE***
- Setup non-ISDN Progress Indicator IE Enable****
- MCDN Channel Number Extension Bit Set to Zero**
- Send Calling Name In Facility IE
- Interface Identifier Present**

Interface Identifier Value**

Connected Line ID Presentation (QSIG Inbound Call)*

UUIE Configuration

- Passing Precedence Level Through UUIE

Security Access Level

Product Specific Configuration

Line Coding*

Framing*

Clock*

Input Gain (-6..14 db)*

Output Attenuation (-6..14 db)*

Echo Cancellation Enable*

Echo Cancellation Coverage (ms)*

* indicates required item



CallBack Softkey Template Configuration

Find and List Softkey Templates

[Add a New Softkey Template](#)

7 matching record(s) for Name begins with ""

Find softkey templates where begins with

and show items per page, where softkey template is

To list all items, click Find without entering any search text.

Matching record(s) 1 to 7 of 7

<input type="checkbox"/>	Name	Description	Copy
<input checked="" type="checkbox"/>	Standard IPMA Assistant	Standard template for IPMA assistant inter...	
<input checked="" type="checkbox"/>	Standard User	Standard Softkey Template for CallManager ...	
<input checked="" type="checkbox"/>	Standard Feature	Standard Softkey Template for CM Combined ...	
<input checked="" type="checkbox"/>	Standard IPMA Manager	Standard template for IPMA manager interface	
<input type="checkbox"/>	Custom Feature	Softkey Template for CM Combined Feature	
<input checked="" type="checkbox"/>	Standard IPMA Shared Mode Manager	Standard template for IPMA shared mode man...	
<input type="checkbox"/>	QSIG custom	Standard Softkey Template for CM Combined ...	

[First](#) [Previous](#) [Next](#) [Last](#)

Page of 1

Softkey Template Configuration

[Add New Softkey Template](#)

[Configure Softkey Layout](#)

[Dependency Records](#)

[Back to Find/List Softkey Templates](#)

Softkey Template: QSIG custom

Status: Ready

Softkey Template Name*

Description

Application

* indicates required item



Softkey Layout Configuration

[Softkey Template Configuration](#)

Call States

- Connected
- Connected Conference
- Connected Transfer
- Digits After First
- Off Hook
- Off Hook With Feature
- On Hold
- On Hook**
- Remote In Use
- Ring In
- Ring Out

Softkey Template: QSIG custom

Status: Ready

Update

Restart Devices

Unselected Softkeys

Conference List (30)(ConfList)
Group Pick Up (18)(GPickUp)
Immediate Divert (31)(iDivert)
Join (15)(Join)
Other Pickup (34)(oPickup)
Pick Up (17)(PickUp)
Quality Report Tool (22)(QRT)
Remove Last Conference Party (19)
Select (29)(Select)
Undefined (0)(Undefined)
Video Mode Command (33)(VidMoc)

Selected Softkeys (ordered by position)**

Redial (1)(Redial)
**NewCall (2)(NewCall)
Forward All (5)(CfwdAll)
Call Back (20)(CallBack)
Direct Transfer (28)(DirTrfr)

** indicates mandatory fields

* indicates required item



IP Phone Configuration

Find and List Phones

[Add a New Phone](#)

3 matching record(s) for Device Name begins with ""







Find phones where begins with

and show items per page. Allow wildcards.

To list all items, click Find without entering any search text, or use "Device Name is not empty" as the search.

Matching record(s) 1 to 3 of 3

Real-time Information Service returned information for 3 of 3 devices listed below.

<input type="checkbox"/>	Device Name	Description	Device Pool	Status	IP Address	Copy
<input type="checkbox"/>	 7960 SEP0003E30CCEA3	Auto 3002	Default	172.20.16.250	172.20.16.103	
<input type="checkbox"/>	 7940 SEP001120967886	Auto 3003	Default	172.20.16.250	172.20.16.101	
<input type="checkbox"/>	 7960 SEP0011219E56A7	Auto 3001	Default	172.20.16.250	172.20.16.102	

First Previous Next Last

Page of 1



Phone Configuration

- [Add a new phone](#)
- [Add/Update Speed Dials](#)
- [Subscribe/Unsubscribe Services](#)
- [Dependency Records](#)
- [Back to Find/List Phones](#)

Directory Numbers

Base Phone

- 7718 Line 1 - 3001 in
- 7719 CiscoPartition
- 7718 Line 2 - Add new DN
- 7719

Phone: SEP0011219E56A7 (Auto 3001)
 Registration: Registered with Cisco CallManager 172.20.16.250
 IP Address: [172.20.16.102](#)

Status: Ready

Phone Configuration (Model = Cisco 7960)

Device Information

MAC Address*	<input type="text" value="0011219E56A7"/>
Description	<input type="text" value="Auto 3001"/>
Owner User ID	<input type="text"/> (Select User ID)
Device Pool*	<input type="text" value="Default"/> (View details)
Calling Search Space	<input type="text" value="IPphones"/>
AAR Calling Search Space	<input type="text" value="IPphones"/>
Media Resource Group List	<input type="text" value="< None >"/>
User Hold Audio Source	<input type="text" value="1 - SampleAudioSource"/>
Network Hold Audio Source	<input type="text" value="1 - SampleAudioSource"/>
Location	<input type="text" value="< None >"/>
User Locale	<input type="text" value="English United States"/>
Network Locale	<input type="text" value="United States"/>
Device Security Mode	<input type="text" value="Use System Default"/>
	<small>Device security mode only takes effect if the enterprise parameter Cluster Security Mode is set to 1</small>
Signal Packet Capture Mode	<input type="text" value="None"/>
Packet Capture Duration	<input type="text" value="0"/>
Built In Bridge	<input type="text" value="Default"/>
Privacy	<input type="text" value="Default"/>
<input checked="" type="checkbox"/> Retry Video Call as Audio	
<input type="checkbox"/> Ignore Presentation Indicators (internal calls only)	

Phone Button Template Information

Phone Button Template* ([View button list](#))

Softkey Template Information

Softkey Template



Expansion Module Information

Module 1

Module 2

Firmware Load Information (leave blank to use default)

Phone Load Name

Module 1 Load Name (Module 1 selection required)

Module 2 Load Name (Module 2 selection required)

Cisco IP Phone - External Data Locations (leave blank to use default)

Information

Directory

Messages

Services

Authentication Server

Proxy Server

Idle

Idle Timer (seconds)

Extension Mobility (Device Profile) Information

Enable Extension Mobility Feature

Log Out Profile

Log In User ID

Log In Time

Log Out Time

Certification Authority Proxy Function (CAPF) Information

Certificate Operation

Authentication Mode

Authentication String

Key Size (bits)

Operation Completes By** : : : (YYYY : MM : DD : HH)

Certificate Operation Status : None



Multilevel Precedence and Preemption (MLPP) Information

MLPP Domain	<input type="text" value=""/> (e.g., "0000FF")
MLPP Indication	Default
MLPP Preemption	Default

Product Specific Configuration

Disable Speakerphone	<input type="checkbox"/>
Disable Speakerphone and Headset	<input type="checkbox"/>
Forwarding Delay*	Disabled
PC Port*	Enabled
Settings Access*	Enabled
Gratuitous ARP*	Enabled
PC Voice VLAN Access*	Enabled
Video Capabilities*	Disabled
Auto Line Select*	Disabled
Web Access*	Enabled

* indicates a required item.
** Indicates time on Publisher.

[Back to top of page](#)
[Back to Find/List Phones](#)



Directory Number Configuration

[Configure Device \(SEP0011219E56A7\)](#)

[Dependency Records](#)

Associated With

SEP0011219E56A7
7960 (Line 1)

Directory Number: 3001 (CiscoPartition)

Status: Ready

Note: Any update to this Directory Number automatically resets the associated devices

Update

Remove from Device

Reset Devices

Directory Number

Directory Number*

Partition

Directory Number Settings

Voice Mail Profile
(Choose <None> to use default)

Calling Search Space

AAR Group

User Hold Audio Source

Network Hold Audio Source

Auto Answer

Call Forward and Pickup Settings

	Voice Mail	Coverage/ Destination	Calling Search Space
Forward All	<input type="checkbox"/>	<input type="text"/>	<input type="text" value="< None >"/>
Forward Busy Internal	<input type="checkbox"/>	<input type="text"/>	<input type="text" value="IPphones"/>
Forward Busy External	<input type="checkbox"/>	<input type="text"/>	<input type="text" value="IPphones"/>
Forward No Answer Internal	<input type="checkbox"/>	<input type="text" value="4054"/>	<input type="text" value="< None >"/>
Forward No Answer External	<input type="checkbox"/>	<input type="text" value="4054"/>	<input type="text" value="< None >"/>
Forward No Coverage Internal	<input type="checkbox"/>	<input type="text"/>	<input type="text" value="< None >"/>
Forward No Coverage External	<input type="checkbox"/>	<input type="text"/>	<input type="text" value="< None >"/>
No Answer Ring Duration	<input type="text"/>	(seconds)	
Call Pickup Group	<input type="text" value="< None >"/>		(View Details)



MLPP Alternate Party Settings

Target (Destination)
Calling Search Space
No Answer Ring Duration (seconds)

Line Settings for all Devices

Alerting Name

Line Settings for this Device

Display (Internal Caller ID)
Line Text Label
External Phone Number Mask
Message Waiting Lamp Policy
Ring Setting (Phone Idle)
Ring Setting (Phone Active)**

Multiple Call / Call Waiting Settings

Maximum Number of Calls* (1 - 200)
Busy Trigger* (<= Max. Calls)

Forwarded Call Information Display

Caller Name Caller Number
 Redirected Number Dialed Number

* indicates required item; changes to Line or Directory Number settings require restart.



Acronyms

Acronym	Definitions
ANF-PR	Additional Network Feature Path Replacement
AOC	Advice-of-charge. Information element is sent with the connection setup information for incoming Euro-ISDN connections. The AOC IE is used for call charge calculation.
CCM	Cisco CallManager
CCBS	Call Completion to Busy Subscriber
CCNR	Call Completion on No Reply
CFB	Call Forwarding on Busy
CFNR	Call Forwarding No Reply
CFU	Call Forwarding Unconditional
CLIP	Calling Line (Number) Identification Presentation
CLIR	Calling Line (Number) Identification Restriction
CMM	Communication Media Module (CMM) is a Cisco Catalyst® 6500 Series and Cisco 7600 Series line card that provides flexible and high-density T1/E1 gateways
CNIP	Calling Name Identification Presentation
CNIR	Calling Name Identification Restriction
COLP	Connected Line (Number) Identification Presentation
COLR	Connected Line (Number) Identification Restriction
CONP	Connected Name Identification Presentation
CONR	Connected Name Identification Restriction
CT	Call Transfer
MWI	Message Waiting Indicator
PSTN	Public Switched Telephone Network

Important Information

THE SPECIFICATIONS AND INFORMATION REGARDING THE PRODUCTS IN THIS MANUAL ARE SUBJECT TO CHANGE WITHOUT NOTICE. ALL STATEMENTS, INFORMATION, AND RECOMMENDATIONS IN THIS MANUAL ARE BELIEVED TO BE ACCURATE BUT ARE PRESENTED WITHOUT WARRANTY OF ANY KIND, EXPRESS OR IMPLIED. USERS MUST TAKE FULL RESPONSIBILITY FOR THEIR APPLICATION OF ANY PRODUCTS.

IN NO EVENT SHALL CISCO OR ITS SUPPLIERS BE LIABLE FOR ANY INDIRECT, SPECIAL, CONSEQUENTIAL, OR INCIDENTAL DAMAGES, INCLUDING, WITHOUT LIMITATION, LOST PROFITS OR LOSS OR DAMAGE TO DATA ARISING OUT OF THE USE OR INABILITY TO USE THIS MANUAL, EVEN IF CISCO OR ITS SUPPLIERS HAVE BEEN ADVISED OF THE POSSIBILITY OF SUCH DAMAGES.



Test Results

Appendix A

CallManager Software Release

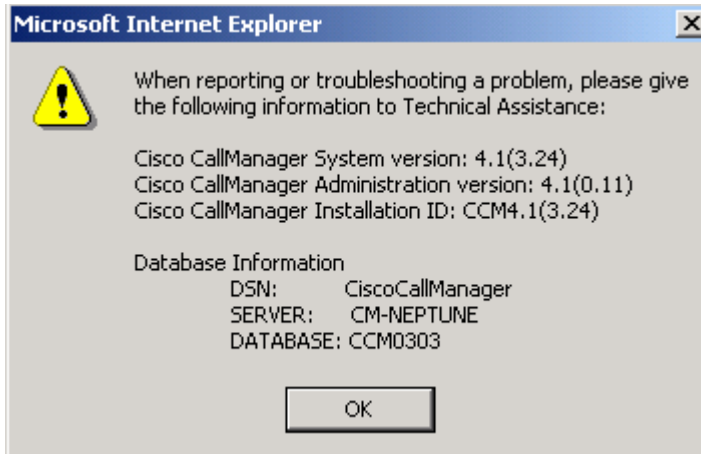

NEC 2400 IPX Software Release

DHDS(Display of HD file issue) [Get] [Exit]

System 0 - ACT - Program loaded drive: - DM loaded drive: -

Drive A				Drive D			
Type	Version	Issue	Date	Type	Version	Issue	Date
Main Memory	15	02.00	2003/10/09	Main Memory	15	02.00	2003/10/09
IP	-	-	-	IP	-	-	-
ACDP	4	08.00	2003/09/04	ACDP	4	08.00	2003/09/04
MAT	15	02.00	2003/09/05	MAT	15	02.00	2003/09/05
TCP/IP	5	01.00	2003/09/04	TCP/IP	5	01.00	2003/09/04
PHDP	2	02.00	2003/08/08	PHDP	2	02.00	2003/08/08



Basic Call Setup End-to-End Configuration

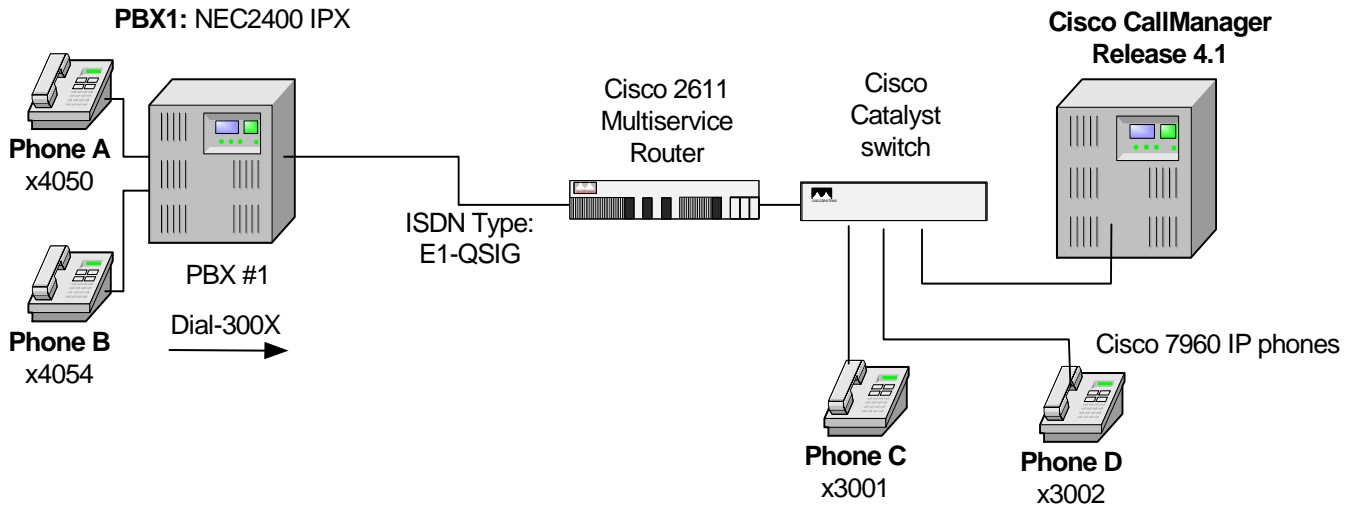

Test Configurations

As shown in the diagram above, an NEC 2400 IPX R15 PBX was connected via an ISDN E1 PRI QSIG link to a Cisco 2611XM-E1 gateway, which in turn was connected to an Ethernet switch. The interoperability testing involved Layers 1, 2, and 3 on the ISDN PRI QSIG link between a Cisco 2611XM-E1 and the PBX.



Appendix B

Test Results

NEC2400 IPX PBX Configured as QSIG, Emulate User and Cisco 2611XM-E1 Gateway Configured as PRI QSIG E1, Emulate Network

Table 1. Basic Calls (Enbloc Sending)

Calls Made	Call Comp.?	Calling Number Displayed on Final Destination?	Calling Name Displayed on Final Destination?	Called Number Displayed on Orig. Side?	Called Name Displayed on Orig. Side?
Phone A to Phone C	Yes	Yes	Yes	Yes	Yes
Phone C to Phone A	Yes	Yes	Yes	Yes	Yes

Table 2. Alerting Names

Calls Made	Call Setup Comp.?	Alerting Name was sent by Final Destination during Alerting (ringing)?	Alerting Name was displayed on Orig. Side during Alerting (ringing)?
Phone A to Phone C -- Phone C does not answer	Yes	Yes	Yes
Phone C to Phone A --- Phone A does not answer	Yes	Yes	Yes

Table 3. Call Transfers (Consultation Local Transfers)

Calls Made	Call Comp?	Orig. Calling Number Displayed on Final Dest. Phone?	Orig. Calling Name Displayed on Final Dest. phone?	Called Number Display on Orig. phone Updated After Transfer?	Called Name Display on Orig. Phone Updated After Transfer?
Phone C to Phone A Xfr to Phone B	Yes	Yes	Yes	No	No
Phone A to Phone C Xfr to Phone D	Yes	Yes	Yes	Yes	Yes

Table 4. Call Transfers (Blind Local Transfers)

Calls Made	Call Comp.?	Orig. Calling Number Displayed on Final Dest. Phone?	Orig. Calling Name Displayed on Final Dest. phone?	Called Number Display on Orig. phone Updated After Transfer?	Called Name Display on Orig. Phone Updated After Transfer?
Phone C to Phone A Xfr to Phone B	Yes	Yes	Yes	No	Yes
Phone A to Phone C Xfr to Phone D	Yes	Yes	Yes	Yes	Yes



Table 5. Call Transfers (Consultation Network/External)

Calls Made	Call Comp.?	Orig. Calling Number Displayed on Final Dest. Phone?	Orig. Calling Name Displayed on Final Dest. Phone?	Called Number Display on Orig. Phone Updated After Transfer?	Called Name Display on Orig. Phone Updated After Transfer?
Phone C to Phone A Xfr to Phone D	Yes	Yes	Yes	Yes	Yes
Phone A to Phone C Xfr to Phone B	Yes	Yes	Yes	Yes	Yes

Table 6. Call Transfers (Blind Network/External)

Calls Made	Call Comp.?	Orig. Calling Number Displayed on Final Dest. Phone?	Orig. Calling Name Displayed on Final Dest. Phone?	Called Number Display on Orig. Phone Updated After Transfer?	Called Name Display on Orig. Phone Updated After Transfer?
Phone C to Phone A Xfr to Phone D	Yes	Yes	Yes	Yes	Yes
Phone A to Phone C Xfr to Phone B	Yes	Yes	Yes	Yes	Yes

Table 7. Call Forward Unconditional by join (Local)

Calls Made	Call Comp.?	Original Calling Number Displayed on Final Dest.?	Original Calling Name Displayed on Final Dest.?	Forwarding Called Number Displayed on Final Dest.?	Forwarding Called Name Displayed on Final Dest.?	Final Dest. Connected Number Updated at orig. Side?	Final Dest. "Connected Name" Updated at Orig. Side?
Phone C to Phone A-CFU to Phone B	Yes	Yes	Yes	Yes	Yes	Yes	No
Phone A to Phone C-CFU to Phone D	Yes	Yes	Yes	Yes	Yes	Yes	Yes

Table 8. Call Forward Unconditional by join (Network/External)

Calls Made	Call Comp.?	Original Calling Number Displayed on Final Dest.?	Original Calling Name Displayed on Final Dest.?	Forwarding Called Number Displayed on Final Dest.?	Forwarding Called Name Displayed on Final Dest.?	Final Dest. Connected Number Updated at Orig. Side?	Final Dest. Connected Name Updated at Orig. Side?
Phone C to Phone A-CFU to Phone D	Yes	Yes	Yes	Yes	Yes	Yes	Yes
Phone A to Phone C-CFU to Phone B	Yes	Yes	No	No	Yes	Yes	Yes

Table 9. Call Forward Busy by join(Local)

Calls Made	Call Comp.?	Original Calling Number Displayed on Final Dest.?	Original Calling Name Displayed on Final Dest.?	Forwarding Called Number Displayed on Final Dest.?	Forwarding Called Name Displayed on Final Dest.?	Final Dest. Connected Number Updated at orig. Side?	Final Dest. "Connected Name" Updated at Orig. Side?
Phone C to Phone A-CFB to Phone B	Yes	Yes	Yes	Yes	No	Yes	No
Phone A to Phone C-CFB to Phone D	Yes	Yes	Yes	Yes	Yes	Yes	Yes



Table 10. Call Forward Busy by join (Network/External)

Calls Made	Call Comp.?	Original Calling Number Displayed on Final Dest.?	Original Calling Name Displayed on Final Dest.?	Forwarding Called Number Displayed on Final Dest.?	Forwarding Called Name Displayed on Final Dest.?	Final Dest. Connected Number Updated at Orig. Side?	Final Dest. Connected Name Updated at Orig. Side?
Phone C to Phone A-CFB to Phone D	Yes	Yes	Yes	Yes	No	Yes	Yes
Phone A to Phone C-CFB to Phone B	Yes	Yes	No	No	Yes	Yes	Yes

Table 11. Call Forward No Reply by join (Local)

Calls Made	Call Comp.?	Original Calling Number Displayed on Final Dest.?	Original Calling Name Displayed on Final Dest.?	Forwarding Called Number Displayed on Final Dest.?	Forwarding Called Name Displayed on Final Dest.?	Final Dest. Connected Number Updated at Orig. Side?	Final Dest. "Connected Name" Updated at Orig. Side?
Phone C to Phone A-CFNR to Phone B	Yes	Yes	Yes	Yes	No	Yes	No
Phone A to Phone C-CFNR to Phone D	Yes	Yes	Yes	Yes	Yes	Yes	Yes

Table 12. Call Forward No Reply by join (Network/External)

Calls Made	Call Comp.?	Original Calling Number Displayed on Final Dest.?	Original Calling Name Displayed on Final Dest.?	Forwarding Called Number Displayed on Final Dest.?	Forwarding Called Name Displayed on Final Dest.?	Final Dest. Connected Number Updated at Orig. Side?	Final Dest. Connected Name Updated at Orig. Side?
Phone C to Phone A-CFNR to Phone D	Yes	Yes	Yes	Yes	No	Yes	Yes
Phone A to Phone C-CFNR to Phone B	Yes	Yes	No	No	Yes	Yes	Yes

Table 13. Call Completion to Busy Subscriber

Calls Made	Call Back Comp.?	Original Calling Number Displayed on Final Dest.?	Original Calling Name Displayed on Final Dest.?	Final Dest. Connected Number Updated at Orig. Side?	Final Dest. Connected Name Updated at Orig. Side?
Phone C to Phone A-Busy Subscriber Invoke CallBack feature from C	Yes	Yes	Yes	Yes	Yes
Phone A to Phone C-Busy Subscriber Invoke CallBack feature from A	Yes	Yes	No	Yes	Yes



Table 14. Call Completion on No Reply

Calls Made	CallBack Comp.?	Original Calling Number Displayed on Final Dest.?	Original Calling Name Displayed on Final Dest.?	Final Dest. Connected Number Updated at Orig. Side?	Final Dest. Connected Name Updated at Orig. Side?
Phone C to Phone A-No Reply Invoke CallBack feature from C	Yes	Yes	Yes	Yes	Yes
Phone A to Phone C-No Reply Invoke CallBack feature from A	Yes	Yes	No	Yes	Yes

Table 15. Path Replacement for Trombone connection

Calls Made	Call Comp.?	PR was successful?	Original Calling Number Displayed on Final Dest.?	Original Calling Name Displayed on Final Dest.?	Final Dest. Connected Number Updated at Orig. Side?	Final Dest. Connected Name Updated at Orig. Side?
Phone C to Phone A-Xfr to Phone D CCM sends PR proposal	Yes	Yes	Yes	Yes	Yes	Yes
Phone A to Phone C-Xfr to Phone B PBX sends PR proposal	Yes	Yes	Yes	Yes	Yes	Yes



ISDN Traces

Cisco CallManager NEC 2400 IPX PBX

Table 3. Call Transfer

```
09:12:57/266.5 1- RS D1 BOP FRAME [0066]
D2 Q921 (S:00 T:000 C/R:1) I P:0 NR:018 NS:013 [0062]
D3 QSIG Pro:08 Ref:(O,00 03) SETUP
IE:(0/a1) len:0 >> Sending complete
IE:(0/04) len:3 >> Bearer capability
Oct 3 : -00----- Coding = ITU-T
        ---00000 Capability = Speech
Oct 4 : -00----- Transfer mode = Circuit
        ---10000 Transfer rate = 64 Kbit/s
Oct 5 : -0100010 L1 protocol = G711 u-law
IE:(0/18) len:3 >> Channel identification
Oct 3 : -0----- Interf ID = Implicit
        --1----- Interface = Primary
        ----1--- Preferred/Exclusive = Exclusive
        -----0-- D-chan ind = not D-channel
        -----01 Channel select = Indication follows
Oct 32: -00----- Coding = ITU-T
        ---0---- Number/Map = Number
        ----0011 Type = B-channel
Oct 33: -0011110 Channel number = 30
IE:(0/1c) len:29 >> Facility
Oct 3 : ---11111 Profile = Networking ext.
NetworkFacilityExtension { -- SEQUENCE --
    sourceEntity endPINX(0),
    destinationEntity endPINX(0)
}
invoke { -- SEQUENCE --
    invokeID 1,
    operationValue localValue 0,
    argument -- "callingName" --
        namePresentationAllowedSimple '49 50 2d 50 68 6f 6e 65 5f 43
'H -- "IP-Phone_C" --
}
IE:(0/6c) len:6 >> Calling party number
Oct 3 : -000---- Type of number = Unknown
        ----0000 Numbering plan = Unknown
Oct 3a: -00----- Presentation = Allowed
        -----01 Screening = User, verified/passed
Oct 4 : ***** Number = 3001
IE:(0/70) len:5 >> Called party number
Oct 3 : -000---- Type of number = Unknown
        ----0000 Numbering plan = Unknown
Oct 4 : ***** Number = 4050
09:12:57/309.3 1- TS D1 BOP FRAME [0004]
D2 Q921 (S:00 T:000 C/R:1) RR P/F:0 NR:014
09:12:57/313.3 1- TS D1 BOP FRAME [0014]
D2 Q921 (S:00 T:000 C/R:0) I P:0 NR:014 NS:018 [0010]
D3 QSIG Pro:08 Ref:(D,00 03) CALL PROCEEDING
IE:(0/18) len:3 >> Channel identification
Oct 3 : -0----- Interf ID = Implicit
        --1----- Interface = Primary
        ----1--- Preferred/Exclusive = Exclusive
        -----0-- D-chan ind = not D-channel
```



```
-----01 Channel select = Indication follows
Oct 32: -00----- Coding = ITU-T
-----0---- Number/Map = Number
-----0011 Type = B-channel
Oct 33: -0011110 Channel number = 30
09:12:57/317.5 1- RS D1 BOP FRAME [0004]
D2 Q921 (S:00 T:000 C/R:0) RR P/F:0 NR:019
09:12:57/320.8 1- TS D1 BOP FRAME [0046]
D2 Q921 (S:00 T:000 C/R:0) I P:0 NR:014 NS:019 [0042]
D3 QSIG Pro:08 Ref:(D,00 03) ALERTING
IE:(0/1c) len:35 >> Facility
Oct 3 : ---11111 Profile = Networking ext.
NetworkFacilityExtension { -- SEQUENCE --
sourceEntity endPINX(0),
destinationEntity endPINX(0)
}
invoke { -- SEQUENCE --
invokeID 43,
operationValue localValue 1,
argument -- "calledName" --
namePresentationAllowedSimple '53 74 61 74 69 6f 6e 2d 41 20
20 20 20 20 20 20 'H -- "Statio
n-A " --
}
09:12:57/325.4 1- RS D1 BOP FRAME [0004]
D2 Q921 (S:00 T:000 C/R:0) RR P/F:0 NR:020
09:12:58/645.0 1- TS D1 BOP FRAME [0058]
D2 Q921 (S:00 T:000 C/R:0) I P:0 NR:014 NS:020 [0054]
D3 QSIG Pro:08 Ref:(D,00 03) CONNECT
IE:(0/1c) len:35 >> Facility
Oct 3 : ---11111 Profile = Networking ext.
NetworkFacilityExtension { -- SEQUENCE --
sourceEntity endPINX(0),
destinationEntity endPINX(0)
}
invoke { -- SEQUENCE --
invokeID 44,
operationValue localValue 2,
argument -- "connectedName" --
namePresentationAllowedSimple '53 74 61 74 69 6f 6e 2d 41 20
20 20 20 20 20 20 'H -- "Statio
n-A " --
}
IE:(0/1e) len:2 >> Progress indicator
Oct 3 : -00----- Coding = ITU-T
-----0000 Loc = User
Oct 4 : -0000010 2 = Destination address non-ISDN
IE:(0/4c) len:6 >> Connected number
Oct 3 : -000---- Type of number = Unknown
-----0000 Numbering plan = Unknown
Oct 3a: -00----- Presentation = Allowed
-----01 Screening = User, verified/passed
Oct 4 : ***** Number = 4050
09:12:58/649.5 1- RS D1 BOP FRAME [0004]
D2 Q921 (S:00 T:000 C/R:0) RR P/F:0 NR:021
09:12:58/666.3 1- RS D1 BOP FRAME [0009]
D2 Q921 (S:00 T:000 C/R:1) I P:0 NR:021 NS:014 [0005]
D3 QSIG Pro:08 Ref:(O,00 03) CONNECT ACKNOWLEDGE
09:12:58/676.5 1- TS D1 BOP FRAME [0004]
D2 Q921 (S:00 T:000 C/R:1) RR P/F:0 NR:015
09:13:04/461.7 1- TS D1 BOP FRAME [0065]
```



```
D2 Q921 (S:00 T:000 C/R:0) I P:0 NR:015 NS:021 [0061]
D3 QSIG Pro:08 Ref:(D,00 03) FACILITY
IE:(0/1c) len:54 >> Facility
Oct 3 : ---11111 Profile = Networking ext.
NetworkFacilityExtension { -- SEQUENCE --
    sourceEntity endPINX(0),
    destinationEntity endPINX(0)
}
invoke { -- SEQUENCE --
    invokeID 45,
    operationValue localValue 12,
    argument -- "callTransferComplete" --
    { -- SEQUENCE --
        endDesignation primaryEnd(0),
        redirectionNumber presentationRestrictedNumber { -- SEQUENCE
--
            unknownPartyNumber '34 30 35 34 'H -- "4054" -- ,
            networkProvided(3)
        },
        redirectionName namePresentationRestrictedSimple '53 74 61 74
69 6f 6e 2d 42 20 20 20 20 20 2
            0 20 'H -- "Station-B" -- ,
            callStatus answered(0)
        }
    }
}
09:13:04/466.0 1- RS D1 BOP FRAME [0004]
D2 Q921 (S:00 T:000 C/R:0) RR P/F:0 NR:022
09:13:04/540.5 1- RS D1 BOP FRAME [0050]
D2 Q921 (S:00 T:000 C/R:1) I P:0 NR:022 NS:015 [0046]
D3 QSIG Pro:08 Ref:(O,00 03) FACILITY
IE:(0/1c) len:39 >> Facility
Oct 3 : ---11111 Profile = Networking ext.
NetworkFacilityExtension { -- SEQUENCE --
    sourceEntity endPINX(0),
    destinationEntity endPINX(0)
}
InterpretationApdu rejectAnyUnrecognisedInvokePdu(2)
invoke { -- SEQUENCE --
    invokeID 9,
    operationValue localValue 4,
    argument -- "pathReplacePropose" --
    { -- SEQUENCE --
        callIdentity '31 30 30 36 'H -- "1006" -- ,
        rerouteingNumber privatePartyNumber { -- SEQUENCE --
            privateTypeOfNumber localNumber(4),
            privateNumberDigits '33 30 30 31 'H -- "3001" --
        }
    }
}
09:13:04/593.1 1- TS D1 BOP FRAME [0114]
D2 Q921 (S:00 T:000 C/R:0) I P:0 NR:016 NS:022 [0110]
D3 QSIG Pro:08 Ref:(O,00 8d) SETUP
IE:(0/a1) len:0 >> Sending complete
IE:(0/04) len:3 >> Bearer capability
Oct 3 : -00----- Coding = ITU-T
        ---00000 Capability = Speech
Oct 4 : -00----- Transfer mode = Circuit
        ---10000 Transfer rate = 64 Kbit/s
Oct 5 : -0100011 L1 protocol = G711 A-law
IE:(0/18) len:3 >> Channel identification
Oct 3 : -0----- Interf ID = Implicit
```



```

--1----- Interface = Primary
----1--- Preferred/Exclusive = Exclusive
-----0-- D-chan ind = not D-channel
-----01 Channel select = Indication follows
Oct 32: -00----- Coding = ITU-T
      ---0---- Number/Map = Number
      ----0011 Type = B-channel
Oct 33: -0011101 Channel number = 29
IE:(0/1c) len:35 >> Facility
Oct 3 : ---11111 Profile = Networking ext.
NetworkFacilityExtension { -- SEQUENCE --
  sourceEntity endPINX(0),
  destinationEntity endPINX(0)
}
  invoke { -- SEQUENCE --
    invokeID 47,
    operationValue localValue 0,
    argument -- "callingName" --
      namePresentationAllowedSimple '53 74 61 74 69 6f 6e 2d 42 20
20 20 20 20 20 20 'H -- "Statio
      n-B          " --
  }
IE:(0/1c) len:28 >> Facility
Oct 3 : ---11111 Profile = Networking ext.
NetworkFacilityExtension { -- SEQUENCE --
  sourceEntity endPINX(0),
  destinationEntity endPINX(0)
}
InterpretationApdu clearCallIfAnyInvokePduNotRecognised(1)
  invoke { -- SEQUENCE --
    invokeID 46,
    operationValue localValue 5,
    argument -- "pathReplaceSetup" --
      { -- SEQUENCE --
        callIdentity '31 30 30 36 'H -- "1006" --
      }
  }
IE:(0/1e) len:2 >> Progress indicator
Oct 3 : -00----- Coding = ITU-T
      ----0101 Loc = Private net to remote usr
Oct 4 : -0000011 3 = Origination address non-ISDN
IE:(0/6c) len:6 >> Calling party number
Oct 3 : -000---- Type of number = Unknown
      ----0000 Numbering plan = Unknown
Oct 3a: -00----- Presentation = Allowed
      -----01 Screening = User, verified/passed
Oct 4 : ***** Number = 4054
IE:(0/70) len:5 >> Called party number
Oct 3 : -000---- Type of number = Unknown
      ----0000 Numbering plan = Unknown
Oct 4 : ***** Number = 3001
IE:(0/7d) len:2 >> High-layer compatibility
Oct 3 : -00----- Coding = ITU-T
      ---100-- Interpretation = 1st HL char
      -----01 Presentation = Profile
Oct 4 : -0000001 High layer = Telephony
IE:(0/95) len:0 >> Shift-lock
IE:(5/32) len:1 >> Party category
Oct 3 : -----001 Category = Extension
09:13:04/597.7 1- RS D1 BOP FRAME [0004]
D2 Q921 (S:00 T:000 C/R:0) RR P/F:0 NR:023
```



```
09:13:04/714.7 1- RS D1 BOP FRAME [0014]
D2 Q921 (S:00 T:000 C/R:1) I P:0 NR:023 NS:016 [0010]
D3 QSIG Pro:08 Ref:(D,00 8d) CALL PROCEEDING
IE:(0/18) len:3 >> Channel identification
Oct 3 : -0----- Interf ID = Implicit
--1----- Interface = Primary
----1--- Preferred/Exclusive = Exclusive
-----0-- D-chan ind = not D-channel
-----01 Channel select = Indication follows
Oct 32: -00----- Coding = ITU-T
---0---- Number/Map = Number
----0011 Type = B-channel
Oct 33: -0011101 Channel number = 29

09:13:04/719.1 1- RS D1 BOP FRAME [0032]
D2 Q921 (S:00 T:000 C/R:1) I P:0 NR:023 NS:017 [0028]
D3 QSIG Pro:08 Ref:(D,00 8d) CONNECT
IE:(0/1c) len:21 >> Facility
Oct 3 : ---11111 Profile = Networking ext.
NetworkFacilityExtension { -- SEQUENCE --
sourceEntity endPINX(0),
destinationEntity endPINX(0)
}
retResult { -- SEQUENCE --
invokeID 46,
{ -- SEQUENCE --
operationValue localValue 5,
result -- "pathReplaceSetup" --
NULL
}
}

09:13:04/732.0 1- TS D1 BOP FRAME [0004]
D2 Q921 (S:00 T:000 C/R:1) RR P/F:0 NR:018

09:13:04/770.4 1- TS D1 BOP FRAME [0013]
D2 Q921 (S:00 T:000 C/R:0) I P:0 NR:018 NS:023 [0009]
D3 QSIG Pro:08 Ref:(D,00 03) DISCONNECT
IE:(0/08) len:2 >> Cause
Oct 3 : -00----- Coding = ITU-T
----0001 Loc = Private net to local usr
Oct 4 : -0010000 016 = Normal clearing

09:13:04/774.8 1- RS D1 BOP FRAME [0004]
D2 Q921 (S:00 T:000 C/R:0) RR P/F:0 NR:024

09:13:04/781.5 1- TS D1 BOP FRAME [0009]
D2 Q921 (S:00 T:000 C/R:0) I P:0 NR:018 NS:024 [0005]
D3 QSIG Pro:08 Ref:(O,00 8d) CONNECT ACKNOWLEDGE

09:13:04/786.3 1- RS D1 BOP FRAME [0004]
D2 Q921 (S:00 T:000 C/R:0) RR P/F:0 NR:025

09:13:04/809.5 1- RS D1 BOP FRAME [0009]
D2 Q921 (S:00 T:000 C/R:1) I P:0 NR:025 NS:018 [0005]
D3 QSIG Pro:08 Ref:(O,00 03) RELEASE

09:13:04/833.6 1- TS D1 BOP FRAME [0004]
D2 Q921 (S:00 T:000 C/R:1) RR P/F:0 NR:019

09:13:04/847.0 1- TS D1 BOP FRAME [0009]
D2 Q921 (S:00 T:000 C/R:0) I P:0 NR:019 NS:025 [0005]
D3 QSIG Pro:08 Ref:(D,00 03) RELEASE COMPLETE

09:13:04/851.2 1- RS D1 BOP FRAME [0004]
D2 Q921 (S:00 T:000 C/R:0) RR P/F:0 NR:026
```

Table 7. (Call Forward Unconditional)



```
09:57:51/783.8 1- RS D1 BOP FRAME [0004]
D2 Q921 (S:00 T:000 C/R:0) RR P/F:1 NR:053
09:57:52/248.0 1- TS D1 BOP FRAME [0110]
D2 Q921 (S:00 T:000 C/R:0) I P:0 NR:045 NS:053 [0106]
D3 QSIG Pro:08 Ref:(0,00 91) SETUP
IE:(0/a1) len:0 >> Sending complete
IE:(0/04) len:3 >> Bearer capability
Oct 3 : -00----- Coding = ITU-T
      ---00000 Capability = Speech
Oct 4 : -00----- Transfer mode = Circuit
      ---10000 Transfer rate = 64 Kbit/s
Oct 5 : -0100011 L1 protocol = G711 A-law
IE:(0/18) len:3 >> Channel identification
Oct 3 : -0----- Interf ID = Implicit
      --1----- Interface = Primary
      ----1--- Preferred/Exclusive = Exclusive
      -----0-- D-chan ind = not D-channel
      -----01 Channel select = Indication follows
Oct 32: -00----- Coding = ITU-T
      ---0---- Number/Map = Number
      ----0011 Type = B-channel
Oct 33: -0011110 Channel number = 30
IE:(0/1c) len:35 >> Facility
Oct 3 : ---11111 Profile = Networking ext.
NetworkFacilityExtension { -- SEQUENCE --
  sourceEntity endPINX(0),
  destinationEntity endPINX(0)
}
invoke { -- SEQUENCE --
  invokeID 4,
  operationValue localValue 0,
  argument -- "callingName" --
    namePresentationAllowedSimple '53 74 61 74 69 6f 6e 2d 41 20
20 20 20 20 20 20 'H -- "Statio
      n-A          " --
}
IE:(0/1c) len:24 >> Facility
Oct 3 : ---11111 Profile = Networking ext.
NetworkFacilityExtension { -- SEQUENCE --
  sourceEntity endPINX(0),
  destinationEntity endPINX(0)
}
invoke { -- SEQUENCE --
  invokeID 5,
  operationValue localValue 59,
  argument -- "chargeRequest" --
    { -- SEQUENCE --
      adviceModeCombinations { -- SEQUENCE OF --
        final(4)
      }
    }
}
IE:(0/1e) len:2 >> Progress indicator
Oct 3 : -00----- Coding = ITU-T
      ----0101 Loc = Private net to remote usr
Oct 4 : -0000011 3 = Origination address non-ISDN
IE:(0/6c) len:6 >> Calling party number
Oct 3 : -000---- Type of number = Unknown
      ----0000 Numbering plan = Unknown
Oct 3a: -00----- Presentation = Allowed
```



```
-----01 Screening = User, verified/passed
Oct 4 : ***** Number = 4050
IE:(0/70) len:5 >> Called party number
Oct 3 : -00----- Type of number = Unknown
-----0000 Numbering plan = Unknown
Oct 4 : ***** Number = 3001
IE:(0/7d) len:2 >> High-layer compatibility
Oct 3 : -00----- Coding = ITU-T
-----100-- Interpretation = 1st HL char
-----01 Presentation = Profile
Oct 4 : -0000001 High layer = Telephony
IE:(0/95) len:0 >> Shift-lock
IE:(5/32) len:1 >> Party category
Oct 3 : -----001 Category = Extension
09:57:52/252.4 1- RS D1 BOP FRAME [0004]
D2 Q921 (S:00 T:000 C/R:0) RR P/F:0 NR:054
09:57:52/327.4 1- RS D1 BOP FRAME [0014]
D2 Q921 (S:00 T:000 C/R:1) I P:0 NR:054 NS:045 [0010]
D3 QSIG Pro:08 Ref:(D,00 91) CALL PROCEEDING
IE:(0/18) len:3 >> Channel identification
Oct 3 : -0----- Interf ID = Implicit
--1----- Interface = Primary
----1--- Preferred/Exclusive = Exclusive
-----0-- D-chan ind = not D-channel
-----01 Channel select = Indication follows
Oct 32: -00----- Coding = ITU-T
---0---- Number/Map = Number
----0011 Type = B-channel
Oct 33: -0011110 Channel number = 30
09:57:52/333.5 1- RS D1 BOP FRAME [0045]
D2 Q921 (S:00 T:000 C/R:1) I P:0 NR:054 NS:046 [0041]
D3 QSIG Pro:08 Ref:(D,00 91) FACILITY
IE:(0/1c) len:34 >> Facility
Oct 3 : ---11111 Profile = Networking ext.
NetworkFacilityExtension { -- SEQUENCE --
sourceEntity endPINX(0),
destinationEntity endPINX(0)
}
InterpretationApdu discardAnyUnrecognisedInvokePdu(0)
invoke { -- SEQUENCE --
invokeID 1,
operationValue localValue 20,
argument -- "divertingLegInformation1" --
{ -- SEQUENCE --
diversionReason cfu(1),
subscriptionOption notificationWithDivertedToNr(2),
nominatedNr unknownPartyNumber '34 30 35 34 'H -- "4054" --
}
}
}
09:57:52/366.1 1- TS D1 BOP FRAME [0004]
D2 Q921 (S:00 T:000 C/R:1) RR P/F:0 NR:047
09:57:52/367.4 1- RS D1 BOP FRAME [0162]
D2 Q921 (S:00 T:000 C/R:1) I P:0 NR:054 NS:047 [0158]
D3 QSIG Pro:08 Ref:(O,00 07) SETUP
IE:(0/a1) len:0 >> Sending complete
IE:(0/04) len:3 >> Bearer capability
Oct 3 : -00----- Coding = ITU-T
---00000 Capability = Speech
Oct 4 : -00----- Transfer mode = Circuit
---10000 Transfer rate = 64 Kbit/s
Oct 5 : -0100010 L1 protocol = G711 u-law
```



```
IE:(0/18) len:3 >> Channel identification
  Oct 3 : -0----- Interf ID = Implicit
          --1----- Interface = Primary
          ----1--- Preferred/Exclusive = Exclusive
          -----0-- D-chan ind = not D-channel
          -----01 Channel select = Indication follows
  Oct 32: -00----- Coding = ITU-T
          ---0----- Number/Map = Number
          ----0011 Type = B-channel
  Oct 33: -0011101 Channel number = 29
IE:(0/1c) len:35 >> Facility
  Oct 3 : ---11111 Profile = Networking ext.
  NetworkFacilityExtension { -- SEQUENCE --
    sourceEntity endPINX(0),
    destinationEntity endPINX(0)
  }
  invoke { -- SEQUENCE --
    invokeID 1,
    operationValue localValue 0,
    argument -- "callingName" --
      namePresentationAllowedSimple '53 74 61 74 69 6f 6e 2d 41 20
20 20 20 20 20 20 'H -- "Statio
          n-A          " --
  }
  IE:(0/1c) len:75 >> Facility
  Oct 3 : ---11111 Profile = Networking ext.
  NetworkFacilityExtension { -- SEQUENCE --
    sourceEntity endPINX(0),
    destinationEntity endPINX(0)
  }
  InterpretationApdu discardAnyUnrecognisedInvokePdu(0)
  invoke { -- SEQUENCE --
    invokeID 1,
    operationValue localValue 21,
    argument -- "divertingLegInformation2" --
      { -- SEQUENCE --
        diversionCounter 1,
        diversionReason cfu(1),
        originalDiversionReason cfu(1),
        divertingNr presentationAllowedNumber unknownPartyNumber '33
30 30 31 'H -- "3001" -- ,
          originalCalledNr presentationAllowedNumber unknownPartyNumber
'33 30 30 31 'H -- "3001" --
          ,
        redirectingName namePresentationAllowedSimple '43 43 4d 2d 33
30 30 31 'H -- "CCM-3001" --
          ,
        originalCalledName namePresentationAllowedSimple '43 43 4d 2d
33 30 30 31 'H -- "CCM-3001" -
          -
      }
    }
  }
  IE:(0/1e) len:2 >> Progress indicator
  Oct 3 : -00----- Coding = ITU-T
          ----0101 Loc = Private net to remote usr
  Oct 4 : -0000011 3 = Origination address non-ISDN
IE:(0/6c) len:6 >> Calling party number
  Oct 3 : -000---- Type of number = Unknown
          ----0000 Numbering plan = Unknown
  Oct 3a: -00----- Presentation = Allowed
          -----11 Screening = Network provided
```



```
Oct 4 : ***** Number = 4050
IE:(0/70) len:5 >> Called party number
Oct 3 : -000---- Type of number = Unknown
      ----0000 Numbering plan = Unknown
Oct 4 : ***** Number = 4054
IE:(0/74) len:7 >> Invalid/unknown IE code
00 00 8f 33 30 30 31
09:57:52/420.0 1- TS D1 BOP FRAME [0017]
D2 Q921 (S:00 T:000 C/R:0) I P:0 NR:048 NS:054 [0013]
D3 QSIG Pro:08 Ref:(D,00 07) STATUS
IE:(0/08) len:3 >> Cause
Oct 3 : -00----- Coding = ITU-T
      ----0101 Loc = Private net to remote usr
Oct 4 : -1100011 099 = IE non-existent/unimplemented
Oct 5 : 01110100
IE:(0/14) len:1 >> Call state
Oct 3 : 00000110 State = 6
09:57:52/424.0 1- TS D1 BOP FRAME [0014]
D2 Q921 (S:00 T:000 C/R:0) I P:0 NR:048 NS:055 [0010]
D3 QSIG Pro:08 Ref:(D,00 07) CALL PROCEEDING
IE:(0/18) len:3 >> Channel identification
Oct 3 : -0----- Interf ID = Implicit
      --1----- Interface = Primary
      ----1--- Preferred/Exclusive = Exclusive
      -----0-- D-chan ind = not D-channel
      -----01 Channel select = Indication follows
Oct 32: -00----- Coding = ITU-T
      ---0----- Number/Map = Number
      ----0011 Type = B-channel
Oct 33: -0011101 Channel number = 29
09:57:52/424.5 1- RS D1 BOP FRAME [0004]
D2 Q921 (S:00 T:000 C/R:0) RR P/F:0 NR:055
09:57:52/428.6 1- RS D1 BOP FRAME [0004]
D2 Q921 (S:00 T:000 C/R:0) RR P/F:0 NR:056
09:57:52/456.2 1- TS D1 BOP FRAME [0046]
D2 Q921 (S:00 T:000 C/R:0) I P:0 NR:048 NS:056 [0042]
D3 QSIG Pro:08 Ref:(D,00 07) ALERTING
IE:(0/1c) len:35 >> Facility
Oct 3 : ---11111 Profile = Networking ext.
NetworkFacilityExtension { -- SEQUENCE --
  sourceEntity endPINX(0),
  destinationEntity endPINX(0)
}
invoke { -- SEQUENCE --
  invokeID 6,
  operationValue localValue 1,
  argument -- "calledName" --
    namePresentationAllowedSimple '53 74 61 74 69 6f 6e 2d 42 20
20 20 20 20 20 20 'H -- "Statio
      n-B " --
}
09:57:52/460.4 1- RS D1 BOP FRAME [0004]
D2 Q921 (S:00 T:000 C/R:0) RR P/F:0 NR:057
09:57:52/561.0 1- RS D1 BOP FRAME [0050]
D2 Q921 (S:00 T:000 C/R:1) I P:0 NR:057 NS:048 [0046]
D3 QSIG Pro:08 Ref:(D,00 91) ALERTING
IE:(0/1c) len:35 >> Facility
Oct 3 : ---11111 Profile = Networking ext.
NetworkFacilityExtension { -- SEQUENCE --
  sourceEntity endPINX(0),
  destinationEntity endPINX(0)
}
```



```
    }
    invoke { -- SEQUENCE --
      invokeID 1,
      operationValue localValue 1,
      argument -- "calledName" --
        namePresentationAllowedSimple '53 74 61 74 69 6f 6e 2d 42 20
20 20 20 20 20 20 'H -- "Statio
      n-B          " --
    }
    IE:(0/1e) len:2 >> Progress indicator
      Oct 3 : -00----- Coding = ITU-T
        ----0000 Loc = User
      Oct 4 : -0001000 8 = In-band info now available
09:57:52/663.1 1- TS D1 BOP FRAME [0004]
      D2 Q921 (S:00 T:000 C/R:1) RR P/F:0 NR:049
09:57:54/761.4 1- TS D1 BOP FRAME [0065]
      D2 Q921 (S:00 T:000 C/R:0) I P:0 NR:049 NS:057 [0061]
      D3 QSIG Pro:08 Ref:(D,00 07) CONNECT
    IE:(0/1c) len:42 >> Facility
      Oct 3 : ---11111 Profile = Networking ext.
      NetworkFacilityExtension { -- SEQUENCE --
        sourceEntity endPINX(0),
        destinationEntity endPINX(0)
      }
    invoke { -- SEQUENCE --
      invokeID 0,
      operationValue localValue 22,
      argument -- "divertingLegInformation3" --
        { -- SEQUENCE --
          presentationAllowedIndicator TRUE,
          redirectionName namePresentationAllowedSimple '53 74 61 74 69
6f 6e 2d 42 20 20 20 20 20 20 2
          0 'H -- "Station-B          " --
        }
      }
    IE:(0/1e) len:2 >> Progress indicator
      Oct 3 : -00----- Coding = ITU-T
        ----0000 Loc = User
      Oct 4 : -0000010 2 = Destination address non-ISDN
    IE:(0/4c) len:6 >> Connected number
      Oct 3 : -000---- Type of number = Unknown
        ----0000 Numbering plan = Unknown
      Oct 3a: -00----- Presentation = Allowed
        -----01 Screening = User, verified/passed
      Oct 4 : ***** Number = 4054
09:57:54/765.6 1- RS D1 BOP FRAME [0004]
      D2 Q921 (S:00 T:000 C/R:0) RR P/F:0 NR:058
09:57:54/791.2 1- RS D1 BOP FRAME [0009]
      D2 Q921 (S:00 T:000 C/R:1) I P:0 NR:058 NS:049 [0005]
      D3 QSIG Pro:08 Ref:(O,00 07) CONNECT ACKNOWLEDGE
09:57:54/799.5 1- RS D1 BOP FRAME [0065]
      D2 Q921 (S:00 T:000 C/R:1) I P:0 NR:058 NS:050 [0061]
      D3 QSIG Pro:08 Ref:(D,00 91) CONNECT
    IE:(0/1c) len:42 >> Facility
      Oct 3 : ---11111 Profile = Networking ext.
      NetworkFacilityExtension { -- SEQUENCE --
        sourceEntity endPINX(0),
        destinationEntity endPINX(0)
      }
    invoke { -- SEQUENCE --
      invokeID 0,
```



```
operationValue localValue 22,
argument -- "divertingLegInformation3" --
{ -- SEQUENCE --
  presentationAllowedIndicator TRUE,
  redirectionName namePresentationAllowedSimple '53 74 61 74 69
6f 6e 2d 42 20 20 20 20 20 20 2
    0 'H -- "Station-B " --
  }
}
IE:(0/1e) len:2 >> Progress indicator
  Oct 3 : -00----- Coding = ITU-T
            ----0000 Loc = User
  Oct 4 : -000010 2 = Destination address non-ISDN
IE:(0/4c) len:6 >> Connected number
  Oct 3 : -000---- Type of number = Unknown
            ----0000 Numbering plan = Unknown
  Oct 3a: -00----- Presentation = Allowed
            -----11 Screening = Network provided
  Oct 4 : ***** Number = 4054
09:57:54/811.7 1- TS D1 BOP FRAME [0004]
                  D2 Q921 (S:00 T:000 C/R:1) RR P/F:0 NR:051
09:57:54/841.9 1- TS D1 BOP FRAME [0009]
                  D2 Q921 (S:00 T:000 C/R:0) I P:0 NR:051 NS:058 [0005]
                  D3 QSIG Pro:08 Ref:(O,00 91) CONNECT ACKNOWLEDGE
09:57:54/846.1 1- RS D1 BOP FRAME [0004]
                  D2 Q921 (S:00 T:000 C/R:0) RR P/F:0 NR:059
09:57:57/131.3 1- TS D1 BOP FRAME [0013]
                  D2 Q921 (S:00 T:000 C/R:0) I P:0 NR:051 NS:059 [0009]
                  D3 QSIG Pro:08 Ref:(D,00 07) DISCONNECT
                  IE:(0/08) len:2 >> Cause
                    Oct 3 : -00----- Coding = ITU-T
                              ----0001 Loc = Private net to local usr
                    Oct 4 : -0010000 016 = Normal clearing
09:57:57/135.5 1- RS D1 BOP FRAME [0004]
                  D2 Q921 (S:00 T:000 C/R:0) RR P/F:0 NR:060
09:57:57/169.2 1- RS D1 BOP FRAME [0013]
                  D2 Q921 (S:00 T:000 C/R:1) I P:0 NR:060 NS:051 [0009]
                  D3 QSIG Pro:08 Ref:(D,00 91) DISCONNECT
                  IE:(0/08) len:2 >> Cause
                    Oct 3 : -00----- Coding = ITU-T
                              ----0001 Loc = Private net to local usr
                    Oct 4 : -0010000 016 = Normal clearing
09:57:57/190.5 1- RS D1 BOP FRAME [0009]
                  D2 Q921 (S:00 T:000 C/R:1) I P:0 NR:060 NS:052 [0005]
                  D3 QSIG Pro:08 Ref:(O,00 07) RELEASE
09:57:57/213.7 1- TS D1 BOP FRAME [0009]
                  D2 Q921 (S:00 T:000 C/R:0) I P:0 NR:053 NS:060 [0005]
                  D3 QSIG Pro:08 Ref:(O,00 91) RELEASE
09:57:57/218.3 1- RS D1 BOP FRAME [0004]
                  D2 Q921 (S:00 T:000 C/R:0) RR P/F:0 NR:061
09:57:57/230.5 1- TS D1 BOP FRAME [0009]
                  D2 Q921 (S:00 T:000 C/R:0) I P:0 NR:053 NS:061 [0005]
                  D3 QSIG Pro:08 Ref:(D,00 07) RELEASE COMPLETE
09:57:57/235.1 1- RS D1 BOP FRAME [0004]
                  D2 Q921 (S:00 T:000 C/R:0) RR P/F:0 NR:062
09:57:57/250.8 1- RS D1 BOP FRAME [0009]
                  D2 Q921 (S:00 T:000 C/R:1) I P:0 NR:062 NS:053 [0005]
                  D3 QSIG Pro:08 Ref:(D,00 91) RELEASE COMPLETE
09:57:57/351.1 1- TS D1 BOP FRAME [0004]
                  D2 Q921 (S:00 T:000 C/R:1) RR P/F:0 NR:054
```





Corporate Headquarters

Cisco Systems, Inc.
170 West Tasman Drive
San Jose, CA 95134-1706
USA
www.cisco.com
Tel: 408 526-4000
800 553-NETS (6387)
Fax: 408 526-4100

European Headquarters

Cisco Systems International
BV
Haarlerbergpark
Haarlerbergweg 13-19
1101 CH Amsterdam
The Netherlands
www-europe.cisco.com
Tel: 31 0 20 357 1000
Fax: 31 0 20 357 1100

Americas Headquarters

Cisco Systems, Inc.
170 West Tasman Drive
San Jose, CA 95134-1706
USA
www.cisco.com
Tel: 408 526-7660
Fax: 408 527-0883

Asia Pacific Headquarters

Cisco Systems, Inc.
Capital Tower
168 Robinson Road
#22-01 to #29-01
Singapore 068912
www.cisco.com
Tel: +65 317 7777
Fax: +65 317 7799

Cisco Systems has more than 200 offices in the following countries and regions. Addresses, phone numbers, and fax numbers are listed on the Cisco Web site at www.cisco.com/go/offices.

Argentina • Australia • Austria • Belgium • Brazil • Bulgaria • Canada • Chile • China PRC • Colombia • Costa Rica • Croatia • Czech Republic • Denmark • Dubai, UAE • Finland • France • Germany • Greece • Hong Kong SAR • Hungary • India • Indonesia • Ireland • Israel • Italy • Japan • Korea • Luxembourg • Malaysia • Mexico • The Netherlands • New Zealand • Norway • Peru • Philippines • Poland • Portugal • Puerto Rico • Romania • Russia • Saudi Arabia • Scotland • Singapore • Slovakia • Slovenia • South Africa • Spain • Sweden • Switzerland • Taiwan • Thailand • Turkey • Ukraine • United Kingdom • United States • Venezuela • Vietnam • Zimbabwe

© 2005 Cisco Systems, Inc. All rights reserved. CCSP, CCVP, the Cisco Square Bridge logo, Follow Me Browsing, and StackWise are trademarks of Cisco Systems, Inc.; Changing the Way We Work, Live, Play, and Learn, and iQuick Study are service marks of Cisco Systems, Inc.; and Access Registrar, Aironet, ASIST, BPX, Catalyst, CCDA, CCDP, CCIE, CCIP, CCNA, CCNP, Cisco, the Cisco Certified Internetwork Expert logo, Cisco IOS, Cisco Press, Cisco Systems, Cisco Systems Capital, the Cisco Systems logo, Cisco Unity, Empowering the Internet Generation, Enterprise/Solver, EtherChannel, EtherFast, EtherSwitch, Fast Step, FormShare, GigaDrive, GigaStack, HomeLink, Internet Quotient, IOS, IP/TV, iQ Expertise, the iQ logo, iQ Net Readiness Scorecard, LightStream, Linksys, MeetingPlace, MGX, the Networkers logo, Networking Academy, Network Registrar, Packet, PIX, Post-Routing, Pre-Routing, ProConnect, RateMUX, ScriptShare, SlideCast, SMARTnet, StrataView Plus, TeleRouter, The Fastest Way to Increase Your Internet Quotient, and TransPath are registered trademarks of Cisco Systems, Inc. and/or its affiliates in the United States and certain other countries.

All other trademarks mentioned in this document or Website are the property of their respective owners. The use of the word partner does not imply a partnership relationship between Cisco and any other company. (0502R)

Printed in the USA