



## Configuring VTP

---

This chapter describes how to use the VLAN Trunking Protocol (VTP) and the VLAN database for managing VLANs with the Catalyst 3750 switch. Unless otherwise noted, the term *switch* refers to a standalone switch and a switch stack.



### Note

---

For complete syntax and usage information for the commands used in this chapter, refer to the command reference for this release.

---

The chapter includes these sections:

- [Understanding VTP, page 13-1](#)
- [Configuring VTP, page 13-6](#)
- [Monitoring VTP, page 13-16](#)

## Understanding VTP

VTP is a Layer 2 messaging protocol that maintains VLAN configuration consistency by managing the addition, deletion, and renaming of VLANs on a network-wide basis. VTP minimizes misconfigurations and configuration inconsistencies that can cause several problems, such as duplicate VLAN names, incorrect VLAN-type specifications, and security violations.

Before you create VLANs, you must decide whether to use VTP in your network. Using VTP, you can make configuration changes centrally on one or more switches and have those changes automatically communicated to all the other switches in the network. Without VTP, you cannot send information about VLANs to other switches.

VTP is designed to work in an environment where updates are made on a single switch and are sent through VTP to other switches in the domain. It does not work well in a situation where multiple updates to the VLAN database occur simultaneously on switches in the same domain, which would result in an inconsistency in the VLAN database.

VTP functionality is supported across the stack, and all switches in the stack maintain the same VLAN and VTP configuration inherited from the stack master. When a switch learns of a new VLAN through VTP messages or when a new VLAN is configured by the user, the new VLAN information is communicated to all switches in the stack.

When a switch joins the stack or when stacks merge, the new switches get VTP information from the stack master.

The switch supports 1005 VLANs, but the number of routed ports, SVIs, and other configured features affects the usage of the switch hardware. If the switch is notified by VTP of a new VLAN and the switch is already using the maximum available hardware resources, it sends a message that there are not enough hardware resources available and shuts down the VLAN. The output of the **show vlan** user EXEC command shows the VLAN in a suspended state.

VTP only learns about normal-range VLANs (VLAN IDs 1 to 1005). Extended-range VLANs (VLAN IDs greater than 1005) are not supported by VTP or stored in the VTP VLAN database.

This section contains information about these VTP parameters and characteristics.

- [The VTP Domain, page 13-2](#)
- [VTP Modes, page 13-3](#)
- [VTP Advertisements, page 13-3](#)
- [VTP Version 2, page 13-4](#)
- [VTP Pruning, page 13-4](#)
- [VTP and Switch Stacks, page 13-6](#)

## The VTP Domain

A VTP domain (also called a VLAN management domain) consists of one switch or several interconnected switches or switch stacks under the same administrative responsibility sharing the same VTP domain name. A switch can be in only one VTP domain. You make global VLAN configuration changes for the domain by using the command-line interface (CLI), Cluster Management Suite (CMS) software, or Simple Network Management Protocol (SNMP).

By default, the switch is in VTP no-management-domain state until it receives an advertisement for a domain over a trunk link (a link that carries the traffic of multiple VLANs) or until you configure a domain name. Until the management domain name is specified or learned, you cannot create or modify VLANs on a VTP server, and VLAN information is not propagated over the network.

If the switch receives a VTP advertisement over a trunk link, it inherits the management domain name and the VTP configuration revision number. The switch then ignores advertisements with a different domain name or an earlier configuration revision number.



### Caution

Before adding a VTP client switch to a VTP domain, always verify that its VTP configuration revision number is *lower* than the configuration revision number of the other switches in the VTP domain. Switches in a VTP domain always use the VLAN configuration of the switch with the highest VTP configuration revision number. If you add a switch that has a revision number higher than the revision number in the VTP domain, it can erase all VLAN information from the VTP server and VTP domain. See the [“Adding a VTP Client Switch to a VTP Domain”](#) section on page 13-15 for the procedure for verifying and resetting the VTP configuration revision number.

When you make a change to the VLAN configuration on a VTP server, the change is propagated to all switches in the VTP domain. VTP advertisements are sent over all IEEE trunk connections, including Inter-Switch Link (ISL) and IEEE 802.1Q. VTP dynamically maps VLANs with unique names and internal index associates across multiple LAN types. Mapping eliminates excessive device administration required from network administrators.

If you configure a switch for VTP transparent mode, you can create and modify VLANs, but the changes are not sent to other switches in the domain, and they affect only the individual switch. However, configuration changes made when the switch is in this mode are saved in the switch running configuration and can be saved to the switch startup configuration file.

For domain name and password configuration guidelines, see the [“VTP Configuration Guidelines” section on page 13-8](#).

## VTP Modes

You can configure a supported switch stack to be in one of the VTP modes listed in [Table 13-1](#).

**Table 13-1** VTP Modes

VTP Mode	Description
VTP server	<p>In VTP server mode, you can create, modify, and delete VLANs, and specify other configuration parameters (such as the VTP version) for the entire VTP domain. VTP servers advertise their VLAN configurations to other switches in the same VTP domain and synchronize their VLAN configurations with other switches based on advertisements received over trunk links.</p> <p>In VTP server mode, VLAN configurations are saved in nonvolatile RAM (NVRAM). VTP server is the default mode.</p>
VTP client	<p>A VTP client behaves like a VTP server and transmits and receives VTP updates on its trunks, but you cannot create, change, or delete VLANs on a VTP client. VLANs are configured on another switch in the domain that is in server mode.</p> <p>In VTP client mode, VLAN configurations are not saved in NVRAM.</p>
VTP transparent	<p>VTP transparent switches do not participate in VTP. A VTP transparent switch does not advertise its VLAN configuration and does not synchronize its VLAN configuration based on received advertisements. However, in VTP version 2, transparent switches do forward VTP advertisements that they receive from other switches from their trunk interfaces. You can create, modify, and delete VLANs on a switch in VTP transparent mode. The switch must be in VTP transparent mode when you create extended-range VLANs. See the <a href="#">“Configuring Extended-Range VLANs” section on page 12-12</a>.</p> <p>When the switch is in VTP transparent mode, the VTP and VLAN configurations are saved in NVRAM, but they are not advertised to other switches. In this mode, VTP mode and domain name are saved in the switch running configuration and you can save this information in the switch startup configuration file by entering the <b>copy running-config startup-config</b> privileged EXEC command. The running configuration and the saved configuration are the same for all switches in a stack.</p>

## VTP Advertisements

Each switch in the VTP domain sends periodic global configuration advertisements from each trunk port to a reserved multicast address. Neighboring switches receive these advertisements and update their VTP and VLAN configurations as necessary.



### Note

Because trunk ports send and receive VTP advertisements, you must ensure that at least one trunk port is configured on the switch stack and that this trunk port is connected to the trunk port of another switch. Otherwise, the switch cannot receive any VTP advertisements. For more information on trunk ports, see the [“Configuring VLAN Trunks” section on page 12-16](#).

VTP advertisements distribute this global domain information:

- VTP domain name
- VTP configuration revision number
- Update identity and update timestamp
- MD5 digest VLAN configuration, including maximum transmission unit (MTU) size for each VLAN.
- Frame format

VTP advertisements distribute this VLAN information for each configured VLAN:

- VLAN IDs (ISL and 802.1Q)
- VLAN name
- VLAN type
- VLAN state
- Additional VLAN configuration information specific to the VLAN type

## VTP Version 2

If you use VTP in your network, you must decide whether to use version 1 or version 2. By default, VTP operates in version 1.

VTP version 2 supports these features not supported in version 1:

- Token Ring support—VTP version 2 supports Token Ring Bridge Relay Function (TrBRF) and Token Ring Concentrator Relay Function (TrCRF) VLANs. For more information about Token Ring VLANs, see the [“Configuring Normal-Range VLANs”](#) section on page 12-4.
- Unrecognized Type-Length-Value (TLV) support—A VTP server or client propagates configuration changes to its other trunks, even for TLVs it is not able to parse. The unrecognized TLV is saved in NVRAM when the switch is operating in VTP server mode.
- Version-Dependent Transparent Mode—In VTP version 1, a VTP transparent switch inspects VTP messages for the domain name and version and forwards a message only if the version and domain name match. Because VTP version 2 supports only one domain, it forwards VTP messages in transparent mode without inspecting the version and domain name.
- Consistency Checks—In VTP version 2, VLAN consistency checks (such as VLAN names and values) are performed only when you enter new information through the CLI, the Cluster Management Software (CMS), or SNMP. Consistency checks are not performed when new information is obtained from a VTP message or when information is read from NVRAM. If the MD5 digest on a received VTP message is correct, its information is accepted.

## VTP Pruning

VTP pruning increases network available bandwidth by restricting flooded traffic to those trunk links that the traffic must use to reach the destination devices. Without VTP pruning, a switch floods broadcast, multicast, and unknown unicast traffic across all trunk links within a VTP domain even though receiving switches might discard them. VTP pruning is disabled by default.

VTP pruning blocks unneeded flooded traffic to VLANs on trunk ports that are included in the pruning-eligible list. Only VLANs included in the pruning-eligible list can be pruned. By default, VLANs 2 through 1001 are pruning eligible switch trunk ports. If the VLANs are configured as pruning-ineligible, the flooding continues. VTP pruning is supported with VTP version 1 and version 2.

Figure 13-1 shows a switched network without VTP pruning enabled. Port 1 on Switch A and Port 2 on Switch D are assigned to the Red VLAN. If a broadcast is sent from the host connected to Switch A, Switch A floods the broadcast and every switch in the network receives it, even though Switches C, E, and F have no ports in the Red VLAN.

Figure 13-1 Flooding Traffic without VTP Pruning

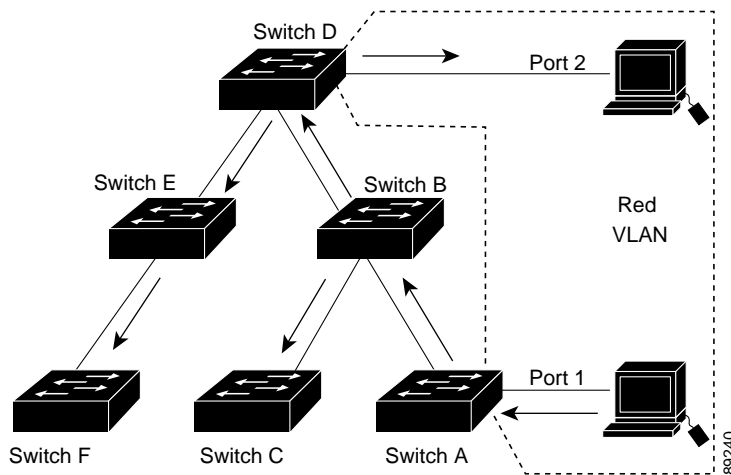
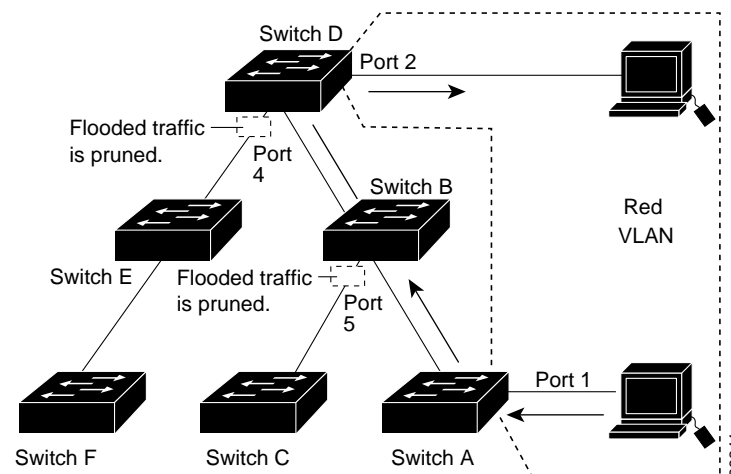

Figure 13-2 shows a switched network with VTP pruning enabled. The broadcast traffic from Switch A is not forwarded to Switches C, E, and F because traffic for the Red VLAN has been pruned on the links shown (Port 5 on Switch B and Port 4 on Switch D).

Figure 13-2 Optimized Flooded Traffic with VTP Pruning



Enabling VTP pruning on a VTP server enables pruning for the entire management domain. Making VLANs pruning-eligible or pruning-ineligible affects pruning eligibility for those VLANs on that trunk only (not on all switches in the VTP domain).

See the “[Enabling VTP Pruning](#)” section on page 13-14. VTP pruning takes effect several seconds after you enable it. VTP pruning does not prune traffic from VLANs that are pruning-ineligible. VLAN 1 and VLANs 1002 to 1005 are always pruning-ineligible; traffic from these VLANs cannot be pruned. Extended-range VLANs (VLAN IDs higher than 1005) are also pruning-ineligible.

VTP pruning is not designed to function in VTP transparent mode. If one or more switches in the network are in VTP transparent mode, you should do one of these:

- Turn off VTP pruning in the entire network.
- Turn off VTP pruning by making all VLANs on the trunk of the switch upstream to the VTP transparent switch pruning ineligible.

To configure VTP pruning on an interface, use the **switchport trunk pruning vlan** interface configuration command (see the “[Changing the Pruning-Eligible List](#)” section on page 12-23). VTP pruning operates when an interface is trunking. You can set VLAN pruning-eligibility, whether or not VTP pruning is enabled for the VTP domain, whether or not any given VLAN exists, and whether or not the interface is currently trunking.

## VTP and Switch Stacks

VTP configuration is the same in all members of a switch stack. When the switch stack is in VTP server or client mode, all switches in the stack carry the same VTP configuration. When VTP mode is transparent, the stack is not taking part in VTP.

- When a switch joins the stack, it inherits the VTP and VLAN properties of the stack master.
- All VTP updates are carried across the stack.
- When VTP mode is changed in a switch in the stack, the other switches in the stack also change VTP mode, and the switch VLAN database remains consistent.

For more information about the switch stack, see [Chapter 5, “Managing Switch Stacks.”](#)

## Configuring VTP

This section includes guidelines and procedures for configuring VTP. These sections are included:

- [Default VTP Configuration, page 13-7](#)
- [VTP Configuration Options, page 13-7](#)
- [VTP Configuration Guidelines, page 13-8](#)
- [Configuring a VTP Server, page 13-9](#)
- [Configuring a VTP Client, page 13-11](#)
- [Disabling VTP \(VTP Transparent Mode\), page 13-12](#)
- [Enabling VTP Version 2, page 13-13](#)
- [Enabling VTP Pruning, page 13-14](#)
- [Adding a VTP Client Switch to a VTP Domain, page 13-15](#)

## Default VTP Configuration

Table 13-2 shows the default VTP configuration.

*Table 13-2 Default VTP Configuration*

Feature	Default Setting
VTP domain name	Null.
VTP mode	Server.
VTP version	Version 1 (version 2 is disabled).
VTP password	None.
VTP pruning	Disabled.

## VTP Configuration Options

You can configure VTP by using these configuration modes.

- [VTP Configuration in Global Configuration Mode, page 13-7](#)
- [VTP Configuration in VLAN Database Configuration Mode, page 13-8](#)

You access VLAN database configuration mode by entering the **vlan database** privileged EXEC command.

For detailed information about **vtp** commands, refer to the command reference for this release.

### VTP Configuration in Global Configuration Mode

You can use the **vtp** global configuration command to set the VTP password, the version, the VTP file name, the interface providing updated VTP information, the domain name, and the mode, and to disable or enable pruning. For more information about available keywords, refer to the command descriptions in the command reference for this release. The VTP information is saved in the VTP VLAN database. When VTP mode is transparent, the VTP domain name and mode are also saved in the switch running configuration file, and you can save it in the switch startup configuration file by entering the **copy running-config startup-config** privileged EXEC command. You must use this command if you want to save VTP mode as transparent, even if the switch resets.

When you save VTP information in the switch startup configuration file and reboot the switch, the switch configuration is determined as follows:

- If the VTP mode is transparent in the startup configuration and the VLAN database and the VTP domain name from the VLAN database matches that in the startup configuration file, the VLAN database is ignored (cleared), and the VTP and VLAN configurations in the startup configuration file are used. The VLAN database revision number remains unchanged in the VLAN database.
- If the VTP mode or domain name in the startup configuration do not match the VLAN database, the domain name and VTP mode and configuration for the first 1005 VLANs use the VLAN database information.

## VTP Configuration in VLAN Database Configuration Mode

You can configure all VTP parameters in VLAN database configuration mode, which you access by entering the **vlan database** privileged EXEC command. For more information about available keywords, refer to the **vtp** VLAN database configuration command description in the command reference for this release. When you enter the **exit** command in VLAN database configuration mode, it applies all the commands that you entered and updates the VLAN database. VTP messages are sent to other switches in the VTP domain, and the privileged EXEC mode prompt appears.

If VTP mode is transparent, the domain name and the mode (transparent) are saved in the switch running configuration, and you can save this information in the switch startup configuration file by entering the **copy running-config startup-config** privileged EXEC command.

## VTP Configuration Guidelines

These sections describe guidelines you should follow when implementing VTP in your network.

### Domain Names

When configuring VTP for the first time, you must always assign a domain name. You must configure all switches in the VTP domain with the same domain name. Switches in VTP transparent mode do not exchange VTP messages with other switches, and you do not need to configure a VTP domain name for them.



#### Note

If NVRAM and DRAM storage is sufficient, all switches in a VTP domain should be in VTP server mode.



#### Caution

Do not configure a VTP domain if all switches are operating in VTP client mode. If you configure the domain, it is impossible to make changes to the VLAN configuration of that domain. Make sure that you configure at least one switch in the VTP domain for VTP server mode.

### Passwords

You can configure a password for the VTP domain, but it is not required. If you do configure a domain password, all domain switches must share the same password and you must configure the password on each switch in the management domain. Switches without a password or with the wrong password reject VTP advertisements.

If you configure a VTP password for a domain, a switch that is booted without a VTP configuration does not accept VTP advertisements until you configure it with the correct password. After the configuration, the switch accepts the next VTP advertisement that uses the same password and domain name in the advertisement.

If you are adding a new switch to an existing network with VTP capability, the new switch learns the domain name only after the applicable password has been configured on it.



#### Caution

When you configure a VTP domain password, the management domain does not function properly if you do not assign a management domain password to each switch in the domain.

## VTP Version

Follow these guidelines when deciding which VTP version to implement:

- All switches in a VTP domain must run the same VTP version.
- A VTP version 2-capable switch can operate in the same VTP domain as a switch running VTP version 1 if version 2 is disabled on the version 2-capable switch (version 2 is disabled by default).
- Do not enable VTP version 2 on a switch unless all of the switches in the same VTP domain are version-2-capable. When you enable version 2 on a switch, all of the version-2-capable switches in the domain enable version 2. If there is a version 1-only switch, it does not exchange VTP information with switches with version 2 enabled.
- If there are TrBRF and TrCRF Token Ring networks in your environment, you must enable VTP version 2 for Token Ring VLAN switching to function properly. To run Token Ring and Token Ring-Net, disable VTP version 2.

## Configuration Requirements

When you configure VTP, you must configure a trunk port on the switch stack so that the switch can send and receive VTP advertisements to and from other switches in the domain.

For more information, see the [“Configuring VLAN Trunks” section on page 12-16](#).

If you are configuring VTP on a cluster member switch to a VLAN, use the **rcommand** privileged EXEC command to log into the member switch. For more information about the command, refer to the command reference for this release.

If you are configuring extended-range VLANs on the switch, the switch must be in VTP transparent mode.

## Configuring a VTP Server

When a switch is in VTP server mode, you can change the VLAN configuration and have it propagated throughout the network.



### Note

If extended-range VLANs are configured on the switch, you cannot change VTP mode to server. You receive an error message, and the configuration is not allowed.

Beginning in privileged EXEC mode, follow these steps to configure the switch as a VTP server:

	Command	Purpose
Step 1	<b>configure terminal</b>	Enter global configuration mode.
Step 2	<b>vtp mode server</b>	Configure the switch for VTP server mode (the default).
Step 3	<b>vtp domain</b> <i>domain-name</i>	Configure the VTP administrative-domain name. The name can be from 1 to 32 characters. All switches operating in VTP server or client mode under the same administrative responsibility must be configured with the same domain name.

	Command	Purpose
Step 4	<b>vtp password</b> <i>password</i>	(Optional) Set the password for the VTP domain. The password can be from 8 to 64 characters.  If you configure a VTP password, the VTP domain does not function properly if you do not assign the same password to each switch in the domain.
Step 5	<b>end</b>	Return to privileged EXEC mode.
Step 6	<b>show vtp status</b>	Verify your entries in the <i>VTP Operating Mode</i> and the <i>VTP Domain Name</i> fields of the display.

When you configure a domain name, it cannot be removed; you can only reassign a switch to a different domain.

To return the switch to a no-password state, use the **no vtp password** global configuration command.

This example shows how to use global configuration mode to configure the switch as a VTP server with the domain name *eng\_group* and the password *mypassword*:

```
Switch# config terminal
Switch(config)# vtp mode server
Switch(config)# vtp domain eng_group
Switch(config)# vtp password mypassword
Switch(config)# end
```

You can also use VLAN database configuration mode to configure VTP parameters.

Beginning in privileged EXEC mode, follow these steps to use VLAN database configuration mode to configure the switch as a VTP server:

	Command	Purpose
Step 1	<b>vlan database</b>	Enter VLAN database configuration mode.
Step 2	<b>vtp server</b>	Configure the switch for VTP server mode (the default).
Step 3	<b>vtp domain</b> <i>domain-name</i>	Configure a VTP administrative-domain name. The name can be from 1 to 32 characters. All switches operating in VTP server or client mode under the same administrative responsibility must be configured with the same domain name.
Step 4	<b>vtp password</b> <i>password</i>	(Optional) Set a password for the VTP domain. The password can be from 8 to 64 characters.  If you configure a VTP password, the VTP domain does not function properly if you do not assign the same password to each switch in the domain.
Step 5	<b>exit</b>	Update the VLAN database, propagate it throughout the administrative domain, and return to privileged EXEC mode.
Step 6	<b>show vtp status</b>	Verify your entries in the <i>VTP Operating Mode</i> and the <i>VTP Domain Name</i> fields of the display.

When you configure a domain name, it cannot be removed; you can only reassign a switch to a different domain.

To return the switch to a no-password state, use the **no vtp password** VLAN database configuration command.

This example shows how to use VLAN database configuration mode to configure the switch as a VTP server with the domain name *eng\_group* and the password *mypassword*:

```
Switch# vlan database
Switch(vlan)# vtp server
Switch(vlan)# vtp domain eng_group
Switch(vlan)# vtp password mypassword
Switch(vlan)# exit
APPLY completed.
Exiting....
Switch#
```

## Configuring a VTP Client

When a switch is in VTP client mode, you cannot change its VLAN configuration. The client switch receives VTP updates from a VTP server in the VTP domain and then modifies its configuration accordingly.



### Note

If extended-range VLANs are configured on the switch stack, you cannot change VTP mode to client. You receive an error message, and the configuration is not allowed.



### Caution

If all switches are operating in VTP client mode, do not configure a VTP domain name. If you do, it is impossible to make changes to the VLAN configuration of that domain. Therefore, make sure you configure at least one switch as a VTP server.

Beginning in privileged EXEC mode, follow these steps to configure the switch as a VTP client:

	Command	Purpose
Step 1	<b>configure terminal</b>	Enter global configuration mode.
Step 2	<b>vtp mode client</b>	Configure the switch for VTP client mode. The default setting is VTP server.
Step 3	<b>vtp domain</b> <i>domain-name</i>	(Optional) Enter the VTP administrative-domain name. The name can be from 1 to 32 characters. This should be the same domain name as the VTP server.  All switches operating in VTP server or client mode under the same administrative responsibility must be configured with the same domain name.
Step 4	<b>vtp password</b> <i>password</i>	(Optional) Enter the password for the VTP domain.
Step 5	<b>end</b>	Return to privileged EXEC mode.
Step 6	<b>show vtp status</b>	Verify your entries in the <i>VTP Operating Mode</i> and the <i>VTP Domain Name</i> fields of the display.

Use the **no vtp mode** global configuration command to return the switch to VTP server mode. To return the switch to a no-password state, use the **no vtp password** privileged EXEC command. When you configure a domain name, it cannot be removed; you can only reassign a switch to a different domain.

**Note**

You can also configure a VTP client by using the **vlan database** privileged EXEC command to enter VLAN database configuration mode and entering the **vtp client** command, similar to the second procedure under “[Configuring a VTP Server](#)” section on page 13-9. Use the **no vtp client** VLAN database configuration command to return the switch to VTP server mode or the **no vtp password** VLAN database configuration command to return the switch to a no-password state. When you configure a domain name, it cannot be removed; you can only reassign a switch to a different domain.

## Disabling VTP (VTP Transparent Mode)

When you configure the switch for VTP transparent mode, you disable VTP on the switch. The switch does not send VTP updates and does not act on VTP updates received from other switches. However, a VTP transparent switch running VTP version 2 does forward received VTP advertisements on all of its trunk links.

**Note**

Before you create extended-range VLANs (VLAN IDs 1006 to 4094), you must set VTP mode to transparent by using the **vtp mode transparent** global configuration command. Save this configuration to the startup configuration so that the switch boots up in VTP transparent mode. Otherwise, you lose the extended-range VLAN configuration if the switch resets and boots up in VTP server mode (the default).

Beginning in privileged EXEC mode, follow these steps to configure VTP transparent mode and save the VTP configuration in the switch startup configuration file:

	Command	Purpose
Step 1	<b>configure terminal</b>	Enter global configuration mode.
Step 2	<b>vtp mode transparent</b>	Configure the switch for VTP transparent mode (disable VTP).
Step 3	<b>end</b>	Return to privileged EXEC mode.
Step 4	<b>show vtp status</b>	Verify your entries in the <i>VTP Operating Mode</i> and the <i>VTP Domain Name</i> fields of the display.
Step 5	<b>copy running-config startup-config</b>	(Optional) Save the configuration in the startup configuration file. <b>Note</b> Only VTP mode and domain name are saved in the switch running configuration and can be copied to the startup configuration file.

To return the switch to VTP server mode, use the **no vtp mode** global configuration command.

**Note**

If extended-range VLANs are configured on the switch stack, you cannot change the VTP mode to server. You receive an error message, and the configuration is not allowed.

**Note**

You can also configure VTP transparent mode by using the **vlan database** privileged EXEC command to enter VLAN database configuration mode and by entering the **vtp transparent** command, similar to the second procedure under the “[Configuring a VTP Server](#)” section on page 13-9. Use the **no vtp transparent** VLAN database configuration command to return the switch to VTP server mode. If extended-range VLANs are configured on the switch, you cannot change VTP mode to server. You receive an error message, and the configuration is not allowed.

## Enabling VTP Version 2

VTP version 2 is disabled by default on VTP version 2-capable switches. When you enable VTP version 2 on a switch, every VTP version 2-capable switch in the VTP domain enables version 2. You can only configure the version on switches in VTP server or transparent mode.

**Caution**

VTP version 1 and VTP version 2 are not interoperable on switches in the same VTP domain. Every switch in the VTP domain must use the same VTP version. Do not enable VTP version 2 unless every switch in the VTP domain supports version 2.

**Note**

In TrCRF and TrBRF Token ring environments, you must enable VTP version 2 for Token Ring VLAN switching to function properly. For Token Ring and Token Ring-Net media, VTP version 2 must be disabled.

For more information on VTP version configuration guidelines, see the “[VTP Version](#)” section on page 13-9.

Beginning in privileged EXEC mode, follow these steps to enable VTP version 2:

	Command	Purpose
Step 1	<b>configure terminal</b>	Enter global configuration mode.
Step 2	<b>vtp version 2</b>	Enable VTP version 2 on the switch. VTP version 2 is disabled by default on VTP version 2-capable switches.
Step 3	<b>end</b>	Return to privileged EXEC mode.
Step 4	<b>show vtp status</b>	Verify that VTP version 2 is enabled in the <i>VTP V2 Mode</i> field of the display.

To disable VTP version 2, use the **no vtp version** global configuration command.

**Note**

You can also enable VTP version 2 by using the **vlan database** privileged EXEC command to enter VLAN database configuration mode and entering the **vtp v2-mode** VLAN database configuration command. To disable VTP version 2, use the **no vtp v2-mode** VLAN database configuration command.

## Enabling VTP Pruning

Pruning increases available bandwidth by restricting flooded traffic to those trunk links that the traffic must use to access the destination devices. You can only enable VTP pruning on a switch in VTP server mode.

Beginning in privileged EXEC mode, follow these steps to enable VTP pruning in the VTP domain:

	Command	Purpose
Step 1	<b>configure terminal</b>	Enter global configuration mode.
Step 2	<b>vtp pruning</b>	Enable pruning in the VTP administrative domain.  By default, pruning is disabled. You need to enable pruning on only one switch in VTP server mode.
Step 3	<b>end</b>	Return to privileged EXEC mode.
Step 4	<b>show vtp status</b>	Verify your entries in the <i>VTP Pruning Mode</i> field of the display.

To disable VTP pruning, use the **no vtp pruning** global configuration command.



### Note

You can also enable VTP pruning by using the **vlan database** privileged EXEC command to enter VLAN database configuration mode and entering the **vtp pruning** VLAN database configuration command. To disable VTP pruning, use the **no vtp pruning** VLAN database configuration command. You can also enable VTP version 2 by using the **vtp pruning** privileged EXEC command. However, this command will not be available in future releases.

Pruning is supported with VTP version 1 and version 2. If you enable pruning on the VTP server, it is enabled for the entire VTP domain.

Only VLANs included in the pruning-eligible list can be pruned. By default, VLANs 2 through 1001 are pruning eligible on trunk ports. Reserved VLANs and extended-range VLANs cannot be pruned. To change the pruning-eligible VLANs, see the [“Changing the Pruning-Eligible List”](#) section on page 12-23.

## Adding a VTP Client Switch to a VTP Domain

Before adding a VTP client to a VTP domain, always verify that its VTP configuration revision number is *lower* than the configuration revision number of the other switches in the VTP domain. Switches in a VTP domain always use the VLAN configuration of the switch with the highest VTP configuration revision number. If you add a switch that has a revision number higher than the revision number in the VTP domain, it can erase all VLAN information from the VTP server and VTP domain.

Beginning in privileged EXEC mode, follow these steps to verify and reset the VTP configuration revision number on a switch *before* adding it to a VTP domain:

	Command	Purpose
Step 1	<b>show vtp status</b>	Check the VTP configuration revision number. If the number is 0, add the switch to the VTP domain. If the number is greater than 0, follow these steps: a. Write down the domain name. b. Write down the configuration revision number. c. Continue with the next steps to reset the switch configuration revision number.
Step 2	<b>configure terminal</b>	Enter global configuration mode.
Step 3	<b>vtp domain domain-name</b>	Change the domain name from the original one displayed in Step 1 to a new name.
Step 4	<b>end</b>	The VLAN information on the switch is updated and the configuration revision number is reset to 0. You return to privileged EXEC mode.
Step 5	<b>show vtp status</b>	Verify that the configuration revision number has been reset to 0.
Step 6	<b>configure terminal</b>	Enter global configuration mode.
Step 7	<b>vtp domain domain-name</b>	Enter the original domain name on the switch.
Step 8	<b>end</b>	The VLAN information on the switch is updated, and you return to privileged EXEC mode.
Step 9	<b>show vtp status</b>	(Optional) Verify that the domain name is the same as in Step 1 and that the configuration revision number is 0.

You can also change the VTP domain name by entering the **vlan database** privileged EXEC command to enter VLAN database configuration mode and by entering the **vtp domain domain-name** command. In this mode, you must enter the **exit** command to update VLAN information and return to privileged EXEC mode.

After resetting the configuration revision number, add the switch to the VTP domain.



### Note

You can use the **vtp mode transparent** global configuration command or the **vtp transparent** VLAN database configuration command to disable VTP on the switch, and then change its VLAN information without affecting the other switches in the VTP domain.

# Monitoring VTP

You monitor VTP by displaying VTP configuration information: the domain name, the current VTP revision, and the number of VLANs. You can also display statistics about the advertisements sent and received by the switch.

[Table 13-3](#) shows the privileged EXEC commands for monitoring VTP activity.

*Table 13-3 VTP Monitoring Commands*

Command	Purpose
<b>show vtp status</b>	Display the VTP switch configuration information.
<b>show vtp counters</b>	Display counters about VTP messages that have been sent and received.