



## Configuring IGMP Snooping and MVR

---

This chapter describes how to configure Internet Group Management Protocol (IGMP) snooping on the Catalyst 3750 switch, including an application of local IGMP snooping, Multicast VLAN Registration (MVR). It also includes procedures for controlling multicast group membership by using IGMP filtering. Unless otherwise noted, the term *switch* refers to a standalone switch and a switch stack.



### Note

---

For complete syntax and usage information for the commands used in this chapter, refer to the switch command reference for this release and the *Cisco IOS Release Network Protocols Command Reference, Part 1, for Release 12.1*.

---

This chapter consists of these sections:

- [Understanding IGMP Snooping, page 15-2](#)
- [Configuring IGMP Snooping, page 15-5](#)
- [Displaying IGMP Snooping Information, page 15-11](#)
- [Understanding Multicast VLAN Registration, page 15-12](#)
- [Configuring MVR, page 15-14](#)
- [Displaying MVR Information, page 15-18](#)
- [Configuring IGMP Filtering, page 15-19](#)
- [Displaying IGMP Filtering Configuration, page 15-22](#)



### Note

---

You can either manage IP multicast group addresses through features such as IGMP snooping and MVR, or you can use static IP addresses.

---

# Understanding IGMP Snooping

Layer 2 switches can use IGMP snooping to constrain the flooding of multicast traffic by dynamically configuring Layer 2 interfaces so that multicast traffic is forwarded to only those interfaces associated with IP multicast devices. As the name implies, IGMP snooping requires the LAN switch to snoop on the IGMP transmissions between the host and the router and to keep track of multicast groups and member ports. When the switch receives an IGMP report from a host for a particular multicast group, the switch adds the host port number to the forwarding table entry; when it receives an IGMP Leave Group message from a host, it removes the host port from the table entry. It also periodically deletes entries if it does not receive IGMP membership reports from the multicast clients.



## Note

For more information on IP multicast and IGMP, refer to RFC 1112 and RFC 2236.

The multicast router (which could be a Catalyst 3750 switch with the enhanced multilayer software image on the stack master) sends out periodic general queries to all VLANs. All hosts interested in this multicast traffic send join requests and are added to the forwarding table entry. The switch creates one entry per VLAN in the IGMP snooping IP multicast forwarding table for each group from which it receives an IGMP join request.

The Catalyst 3750 switch supports IP multicast group-based bridging, rather than MAC-addressed based groups. With multicast MAC address-based groups, if an IP address being configured translates (aliases) to a previously configured MAC address or to any reserved multicast MAC addresses (in the range 224.0.0.xxx), the command fails. Because the Catalyst 3750 switch uses IP multicast groups, there are no address aliasing issues.

The IP multicast groups learned through IGMP snooping are dynamic. However, you can statically configure multicast groups by using the **ip igmp snooping vlan *vlan-id* static *ip\_address* interface *interface-id*** global configuration command. If you specify group membership for a multicast group address statically, your setting supersedes any automatic manipulation by IGMP snooping. Multicast group membership lists can consist of both user-defined and IGMP snooping-learned settings.

If a port spanning-tree, a port group, or a VLAN ID change occurs, the IGMP snooping-learned multicast groups from this port on the VLAN are deleted.

These sections describe characteristics of IGMP snooping on the switch and switch stack:

- [Joining a Multicast Group, page 15-2](#)
- [Leaving a Multicast Group, page 15-4](#)
- [Immediate-Leave Processing, page 15-4](#)
- [IGMP Snooping and Switch Stacks, page 15-5](#)

## Joining a Multicast Group

When a host connected to the switch wants to join an IP multicast group, if it is an IGMP version 2 client, it sends an unsolicited IGMP join message, specifying the IP multicast group to join. Alternatively, when the switch receives a general query from the router, it forwards the query to all ports in the VLAN. IGMP version 1 or version 2 hosts wanting to join the multicast group respond by sending a join message to the switch. The switch CPU creates a multicast forwarding-table entry for the group if it is not already present. The CPU also adds the interface where the join message was received to the forwarding-table entry. The host associated with that interface receives multicast traffic for that multicast group. See [Figure 15-1](#).

Figure 15-1 Initial IGMP Join Message

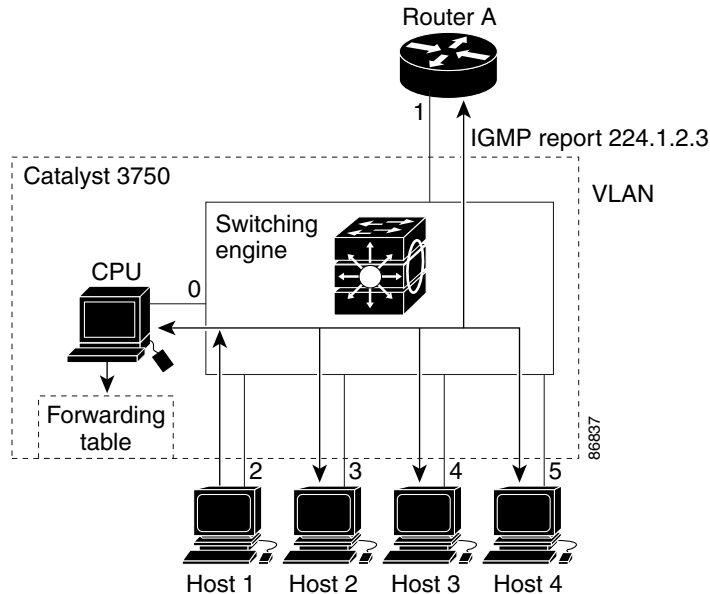

Router A sends a general query to the switch, which forwards the query to ports 2 through 5, all members of the same VLAN. Host 1 wants to join multicast group 224.1.2.3 and multicasts an IGMP membership report (IGMP join message) to the group. When the CPU receives the IGMP report multicast by Host 1, the CPU uses the information in the IGMP report to set up a forwarding-table entry, as shown in Table 15-1, that includes the port numbers connected to Host 1 and the router.

Table 15-1 IGMP Snooping Forwarding Table

Destination Address	Type of Packet	Ports
224.1.2.3	IGMP	1, 2

The switch hardware can distinguish IGMP information packets from other packets for the multicast group. The information in the table tells the switching engine to send frames addressed to the 224.1.2.3 multicast IP address that are not IGMP packets to the router and to the host that has joined the group.

If another host (for example, Host 4) sends an unsolicited IGMP join message for the same group (Figure 15-2), the CPU receives that message and adds the port number of Host 4 to the forwarding table as shown in Table 15-2. Note that because the forwarding table directs IGMP messages to only the CPU, the message is not flooded to other ports on the switch. Any known multicast traffic is forwarded to the group and not to the CPU.

Figure 15-2 Second Host Joining a Multicast Group

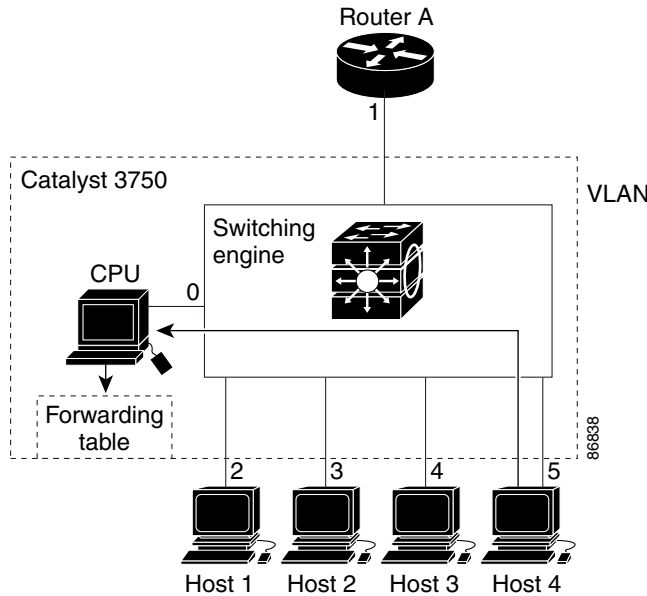

Table 15-2 Updated IGMP Snooping Forwarding Table

Destination Address	Type of Packet	Ports
224.1.2.3	IGMP	1, 2, 5

## Leaving a Multicast Group

The router sends periodic multicast general queries, and the switch forwards these queries through all ports in the VLAN. Interested hosts respond to the queries. If at least one host in the VLAN wishes to receive multicast traffic, the router continues forwarding the multicast traffic to the VLAN. The switch forwards multicast group traffic only to those hosts listed in the forwarding table for that IP multicast group maintained by IGMP snooping.

When hosts want to leave a multicast group, they can silently leave or they can send a leave message. When the switch receives a leave message from a host, it sends out a MAC-based general query to determine if any other devices connected to that interface are interested in traffic for the specific multicast group. The switch then updates the forwarding table for that MAC group so that only those hosts interested in receiving multicast traffic for the group are listed in the forwarding table. If the router receives no reports from a VLAN, it removes the group for the VLAN from its IGMP cache.

## Immediate-Leave Processing

The switch uses IGMP snooping Immediate-Leave processing to remove from the forwarding table an interface that sends a leave message without the switch sending MAC-based general queries to the interface. The VLAN interface is pruned from the multicast tree for the multicast group specified in the original leave message. Immediate-Leave processing ensures optimal bandwidth management for all hosts on a switched network, even when multiple multicast groups are simultaneously in use.

**Note**

You should only use the Immediate-Leave processing feature on VLANs where a single host is connected to each port. If Immediate Leave is enabled in VLANs where more than one host is connected to a port, some hosts might be inadvertently dropped. Immediate Leave is only supported with IGMP version 2 hosts.

## IGMP Snooping and Switch Stacks

IGMP snooping functions across the switch stack; that is, IGMP control information obtained from one switch is distributed to all switches in the stack. (See [Chapter 5, “Managing Switch Stacks,”](#) for more information about switch stacks.) Regardless of the stack member through which IGMP multicast data enters the stack, the data reaches the hosts that have registered for that group.

If a switch in the stack fails or is removed from the stack, only the members of the multicast group that are on that switch will not receive the multicast data. All other members of a multicast group on other switches in the stack continue to receive multicast data streams. However, multicast groups that are common for both Layer 2 and Layer 3 (IP multicast routing) might take longer to converge if the stack master is removed.

## Configuring IGMP Snooping

IGMP snooping allows switches to examine IGMP packets and make forwarding decisions based on their content.

These sections describe how to configure IGMP snooping:

- [Default IGMP Snooping Configuration, page 15-5](#)
- [Enabling or Disabling IGMP Snooping, page 15-6](#)
- [Setting the Snooping Method, page 15-6](#)
- [Configuring a Multicast Router Port, page 15-8](#)
- [Configuring a Host Statically to Join a Group, page 15-9](#)
- [Enabling IGMP Immediate-Leave Processing, page 15-10](#)

## Default IGMP Snooping Configuration

[Table 15-3](#) shows the default IGMP snooping configuration.

**Table 15-3 Default IGMP Snooping Configuration**

Feature	Default Setting
IGMP snooping	Enabled globally and per VLAN
Multicast routers	None configured
Multicast router learning (snooping) method	PIM-DVMRP
IGMP snooping Immediate Leave	Disabled
Static groups	None configured

## Enabling or Disabling IGMP Snooping

By default, IGMP snooping is globally enabled on the switch. When globally enabled or disabled, it is also enabled or disabled in all existing VLAN interfaces. IGMP snooping is by default enabled on all VLANs, but can be enabled and disabled on a per-VLAN basis.

Global IGMP snooping overrides the VLAN IGMP snooping. If global snooping is disabled, you cannot enable VLAN snooping. If global snooping is enabled, you can enable or disable VLAN snooping.

Beginning in privileged EXEC mode, follow these steps to globally enable IGMP snooping on the switch:

	Command	Purpose
Step 1	<code>configure terminal</code>	Enter global configuration mode.
Step 2	<code>ip igmp snooping</code>	Globally enable IGMP snooping in all existing VLAN interfaces.
Step 3	<code>end</code>	Return to privileged EXEC mode.
Step 4	<code>copy running-config startup-config</code>	(Optional) Save your entries in the configuration file.

To globally disable IGMP snooping on all VLAN interfaces, use the **no ip igmp snooping** global configuration command.

Beginning in privileged EXEC mode, follow these steps to enable IGMP snooping on a VLAN interface:

	Command	Purpose
Step 1	<code>configure terminal</code>	Enter global configuration mode.
Step 2	<code>ip igmp snooping vlan <i>vlan-id</i></code>	Enable IGMP snooping on the VLAN interface. The VLAN ID range is 1 to 4094. <b>Note</b> IGMP snooping must be globally enabled before you can enable VLAN snooping.
Step 3	<code>end</code>	Return to privileged EXEC mode.
Step 4	<code>copy running-config startup-config</code>	(Optional) Save your entries in the configuration file.

To disable IGMP snooping on a VLAN interface, use the **no ip igmp snooping vlan *vlan-id*** global configuration command for the specified VLAN number.

## Setting the Snooping Method

Multicast-capable router ports are added to the forwarding table for every Layer 2 multicast entry. The switch learns of such ports through one of these methods:

- Snooping on IGMP queries, Protocol Independent Multicast (PIM) packets, and Distance Vector Multicast Routing Protocol (DVMRP) packets
- Listening to Cisco Group Management Protocol (CGMP) packets from other routers
- Statically connecting to a multicast router port with the **ip igmp snooping mrouter** global configuration command

You can configure the switch either to snoop on IGMP queries and PIM/DVMRP packets or to listen to CGMP self-join or proxy-join packets. By default, the switch snoops on PIM/DVMRP packets on all VLANs. To learn of multicast router ports through only CGMP packets, use the **ip igmp snooping vlan *vlan-id* mrouter learn cgmp** global configuration command. When this command is entered, the router listens to only CGMP self-join and CGMP proxy-join packets and no other CGMP packets. To learn of multicast router ports through only PIM-DVMRP packets, use the **ip igmp snooping vlan *vlan-id* mrouter learn pim-dvmrp** global configuration command.

**Note**

If you want to use CGMP as the learning method and no multicast routers in the VLAN are CGMP proxy-enabled, you must enter the **ip cgmp router-only** command to dynamically access the router. For more information, see [Chapter 28, “Configuring IP Multicast Routing.”](#)

Beginning in privileged EXEC mode, follow these steps to alter the method in which a VLAN interface dynamically accesses a multicast router:

	Command	Purpose
Step 1	<b>configure terminal</b>	Enter global configuration mode.
Step 2	<b>ip igmp snooping vlan <i>vlan-id</i> mrouter learn {cgmp   pim-dvmrp}</b>	Enable IGMP snooping on a VLAN. The VLAN ID range is 1 to 4094. Specify the multicast router learning method: <ul style="list-style-type: none"> <li>• <b>cgmp</b>—Listen for CGMP packets. This method is useful for reducing control traffic.</li> <li>• <b>pim-dvmrp</b>—Snoop on IGMP queries and PIM-DVMRP packets. This is the default.</li> </ul>
Step 3	<b>end</b>	Return to privileged EXEC mode.
Step 4	<b>show ip igmp snooping</b>	Verify the configuration.
Step 5	<b>copy running-config startup-config</b>	(Optional) Save your entries in the configuration file.

This example shows how to configure IGMP snooping to use CGMP packets as the learning method and verify the configuration:

```
Switch# configure terminal
Switch(config)# ip igmp snooping vlan 1 mrouter learn cgmp
Switch(config)# end
Switch# show ip igmp snooping vlan 1
vlan 1
-----
IGMP snooping is globally enabled
IGMP snooping is enabled on this Vlan
IGMP snooping immediate-leave is disabled on this Vlan
IGMP snooping mrouter learn mode is cgmp on this Vlan
IGMP snooping is running in IGMP_ONLY mode on this Vlan
```

To return to the default learning method, use the **no ip igmp snooping vlan *vlan-id* mrouter learn cgmp** global configuration command.

## Configuring a Multicast Router Port

To add a multicast router port (add a static connection to a multicast router), use the **ip igmp snooping vlan mrouter** global configuration command on the switch.

**Note**

Static connections to multicast routers are supported only on switch ports.

Beginning in privileged EXEC mode, follow these steps to enable a static connection to a multicast router:

	Command	Purpose
Step 1	<b>configure terminal</b>	Enter global configuration mode.
Step 2	<b>ip igmp snooping vlan <i>vlan-id</i> mrouter interface <i>interface-id</i></b>	Specify the multicast router VLAN ID and specify the interface to the multicast router. <ul style="list-style-type: none"> <li>The VLAN ID range is 1 to 4094.</li> <li>The interface can be a physical interface or a port channel. The port channel range is 1 to 12.</li> </ul>
Step 3	<b>end</b>	Return to privileged EXEC mode.
Step 4	<b>show ip igmp snooping mrouter [vlan <i>vlan-id</i>]</b>	Verify that IGMP snooping is enabled on the VLAN interface.
Step 5	<b>copy running-config startup-config</b>	(Optional) Save your entries in the configuration file.

To remove a multicast router port from the VLAN, use the **no ip igmp snooping vlan *vlan-id* mrouter interface *interface-id*** global configuration command.

This example shows how to enable a static connection to a multicast router and verify the configuration:

```
Switch# configure terminal
Switch(config)# ip igmp snooping vlan 200 mrouter interface gigabitethernet1/0/2
Switch(config)# end
Switch# show ip igmp snooping mrouter vlan 200
Vlan          ports
-----+-----
200           Gi1/0/2(static)
```

## Configuring a Host Statically to Join a Group

Hosts or Layer 2 ports normally join multicast groups dynamically, but you can also statically configure a host on an interface.

Beginning in privileged EXEC mode, follow these steps to add a Layer 2 port as a member of a multicast group:

	Command	Purpose
Step 1	<code>configure terminal</code>	Enter global configuration mode
Step 2	<code>ip igmp snooping vlan <i>vlan-id</i> static <i>ip_address</i> interface <i>interface-id</i></code>	Statically configure a Layer 2 port as a member of a multicast group: <ul style="list-style-type: none"> <li>• <i>vlan-id</i> is the multicast group VLAN ID.</li> <li>• <i>ip_address</i> is the group IP address.</li> <li>• <i>interface-id</i> is the member port. It can be a physical interface or port channel (1 to 12).</li> </ul>
Step 3	<code>end</code>	Return to privileged EXEC mode.
Step 4	<code>show ip igmp snooping multicast</code>	Verify the member port and the IP address.
Step 5	<code>copy running-config startup-config</code>	(Optional) Save your entries in the configuration file.

To remove the Layer 2 port from the multicast group, use the `no ip igmp snooping vlan vlan-id static mac-address interface interface-id` global configuration command.

This example shows how to statically configure a host on an interface and verify the configuration:

```
Switch# configure terminal
Switch(config)# ip igmp snooping vlan 1 static 224.1.2.3 interface gigabitethernet1/0/1
Switch(config)# end
```

```
Switch# show ip igmp snooping multicast
```

Vlan	Group Address	Type	Ports
----	-----	----	----
1	224.1.2.3	USER	Gi1/0/1

## Enabling IGMP Immediate-Leave Processing

When you enable IGMP Immediate-Leave processing, the switch immediately removes a port when it detects an IGMP version 2 leave message on that port. You should use the Immediate-Leave feature only when there is a single receiver present on every port in the VLAN.



**Note** Immediate Leave is supported with only IGMP version 2 hosts.

Beginning in privileged EXEC mode, follow these steps to enable IGMP Immediate-Leave processing:

	Command	Purpose
Step 1	<code>configure terminal</code>	Enter global configuration mode
Step 2	<code>ip igmp snooping vlan <i>vlan-id</i> immediate-leave</code>	Enable IGMP Immediate-Leave processing on the VLAN interface.
Step 3	<code>end</code>	Return to privileged EXEC mode.
Step 4	<code>show ip igmp snooping vlan <i>vlan-id</i></code>	Verify that Immediate Leave is enabled on the VLAN.
Step 5	<code>copy running-config startup-config</code>	(Optional) Save your entries in the configuration file.

To disable IGMP Immediate-Leave on a VLAN, use the **no ip igmp snooping vlan *vlan-id* immediate-leave** global configuration command.

This example shows how to enable IGMP immediate-leave processing on VLAN 130:

```
Switch# configure terminal
Switch(config)# ip igmp snooping vlan 130 immediate-leave
Switch(config)# end
```

# Displaying IGMP Snooping Information

You can display IGMP snooping information for dynamically learned and statically configured router ports and VLAN interfaces. You can also display MAC address multicast entries for a VLAN configured for IGMP snooping.

To display IGMP snooping information, use one or more of the privileged EXEC commands in [Table 15-4](#).

**Table 15-4** Commands for Displaying IGMP Snooping Information

Command	Purpose
<code>show ip igmp snooping [vlan <i>vlan-id</i>]</code>	<p>Display the snooping configuration information for all VLANs on the switch or for a specified VLAN.</p> <p>(Optional) Enter <b>vlan <i>vlan-id</i></b> to display information for a single VLAN.</p>
<code>show ip igmp snooping multicast [count   dynamic [count   group <i>ip_address</i>]   group <i>ip_address</i>   user [count   group <i>ip_address</i>]]</code>	<p>Display multicast table information for the switch or about a specific parameter:</p> <ul style="list-style-type: none"> <li>• <b>count</b>—Display the total number of entries for the specified command options instead of the actual entries.</li> <li>• <b>dynamic</b>— Display entries learned through IGMP snooping.</li> <li>• <b>group <i>ip_address</i></b>—Display characteristics of the multicast group with the specified group IP address.</li> <li>• <b>user</b>—Display only the user-configured multicast entries.</li> </ul>
<code>show ip igmp snooping multicast vlan <i>vlan-id</i> [count   dynamic [count   group <i>ip_address</i>]   group <i>ip_address</i>   user [count   group <i>ip_address</i>]]</code>	<p>Display multicast table information for a multicast VLAN or about a specific parameter for the VLAN:</p> <ul style="list-style-type: none"> <li>• <b>count</b>—Display the total number of entries for the specified command options instead of the actual entries.</li> <li>• <b>dynamic</b>— Display entries learned through IGMP snooping.</li> <li>• <b>group <i>ip_address</i></b>—Display characteristics of the multicast group with the specified group IP address.</li> <li>• <b>user</b>—Display only the user-configured multicast entries.</li> </ul>
<code>show ip igmp snooping mrouter [vlan <i>vlan-id</i>]</code>	<p>Display information on dynamically learned and manually configured multicast router interfaces.</p> <p><b>Note</b> When you enable IGMP snooping, the switch automatically learns the interface to which a multicast router is connected. These are dynamically learned interfaces.</p> <p>(Optional) Enter <b>vlan <i>vlan-id</i></b> to display information for a single VLAN.</p>

For more information about the keywords and options in these commands, refer to the command reference for this release.

# Understanding Multicast VLAN Registration

Multicast VLAN Registration (MVR) is designed for applications using wide-scale deployment of multicast traffic across an Ethernet ring-based service provider network (for example, the broadcast of multiple television channels over a service-provider network). MVR allows a subscriber on a port to subscribe and unsubscribe to a multicast stream on the network-wide multicast VLAN. It allows the single multicast VLAN to be shared in the network while subscribers remain in separate VLANs. MVR provides the ability to continuously send multicast streams in the multicast VLAN, but to isolate the streams from the subscriber VLANs for bandwidth and security reasons.

MVR assumes that subscriber ports subscribe and unsubscribe (join and leave) these multicast streams by sending out IGMP join and leave messages. These messages can originate from an IGMP version-2-compatible host with an Ethernet connection. Although MVR operates on the underlying mechanism of IGMP snooping, the two features operate independently of each other. One can be enabled or disabled without affecting the behavior of the other feature. However, if IGMP snooping and MVR are both enabled, MVR reacts only to join and leave messages from multicast groups configured under MVR. Join and leave messages from all other multicast groups are managed by IGMP snooping.

The switch CPU identifies the MVR IP multicast streams and their associated IP multicast group in the switch forwarding table, intercepts the IGMP messages, and modifies the forwarding table to include or remove the subscriber as a receiver of the multicast stream, even though the receivers might be in a different VLAN from the source. This forwarding behavior selectively allows traffic to cross between different VLANs.

You can set the switch for compatible or dynamic mode of MVR operation.

- In compatible mode, multicast data received by MVR hosts is forwarded to all MVR data ports, regardless of MVR host membership on those ports. The multicast data is forwarded only to those receiver ports which MVR hosts have explicitly joined, either by IGMP reports or by MVR static configuration. IGMP reports received from MVR hosts are never forwarded out of MVR data ports that were configured in the switch.
- In dynamic mode, multicast data received by MVR hosts on the switch is forwarded from only those MVR data and client ports that the MVR hosts have explicitly joined, either by IGMP reports or by MVR static configuration. Any IGMP reports received from MVR hosts are also forwarded from all the MVR data ports in the switch. This eliminates using unnecessary bandwidth on MVR data port links, which occurs when the switch runs in compatible mode.

Only Layer 2 ports take part in MVR. You must configure ports as MVR receiver ports. Only one MVR multicast VLAN per switch stack is supported.

Receiver ports and source ports can be on different switches in a switch stack. Multicast data sent on the multicast VLAN is forwarded to all MVR receiver ports across the stack. When a new switch is added to a stack, by default it has no receiver ports.

If a switch fails or is removed from the stack, only those receiver ports belonging to that switch will not receive the multicast data. All other receiver ports on other switches continue to receive the multicast data.

## Using MVR in a Multicast Television Application

In a multicast television application, a PC or a television with a set-top box can receive the multicast stream. Multiple set-top boxes or PCs can be connected to one subscriber port, which is a switch port configured as an MVR receiver port. Figure 15-3 is an example configuration. DHCP assigns an IP address to the set-top box or the PC. When a subscriber selects a channel, the set-top box or PC sends an IGMP report to the S1 switch to join the appropriate multicast. If the IGMP report matches one of the configured IP multicast group addresses, the switch CPU modifies the hardware address table to include this receiver port and VLAN as a forwarding destination of the specified multicast stream when it is received from the multicast VLAN. Uplink ports that send and receive multicast data to and from the multicast VLAN are called MVR source ports.

Figure 15-3 Multicast VLAN Registration Example

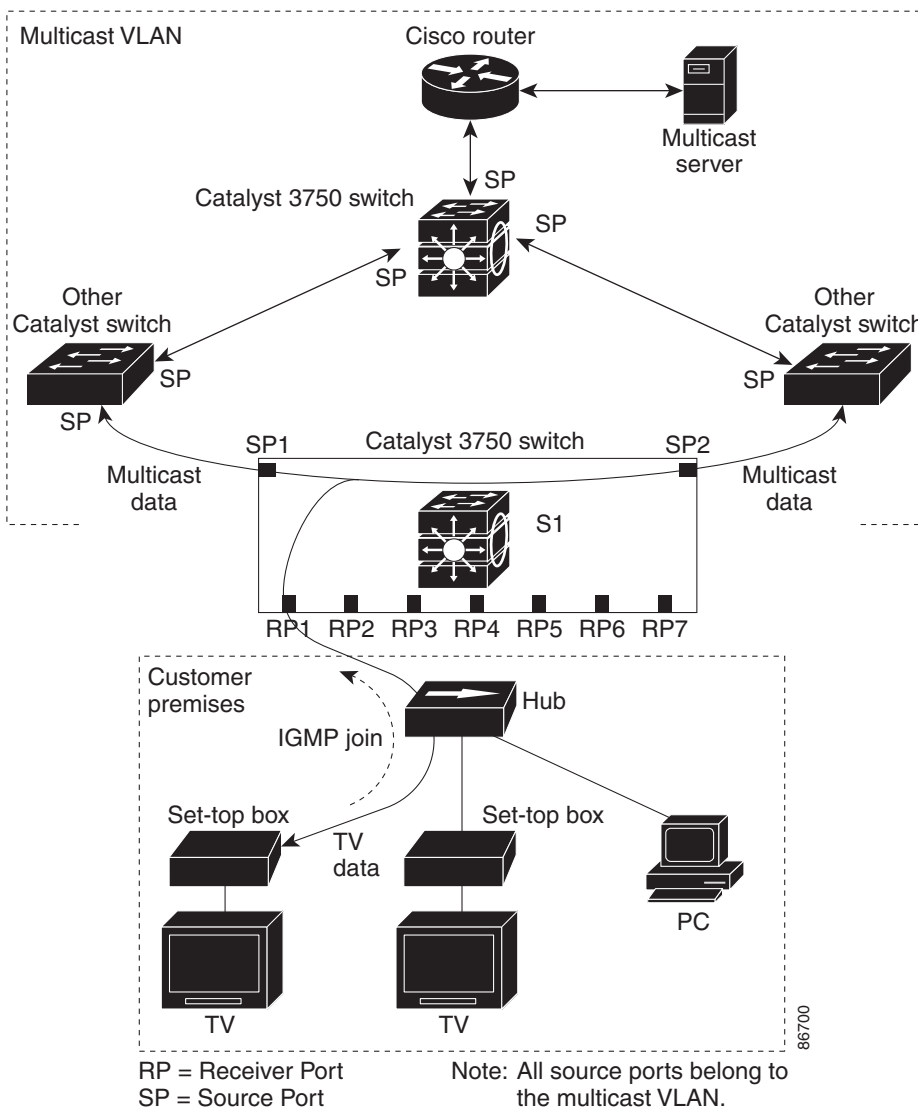

When a subscriber changes channels or turns off the television, the set-top box sends an IGMP leave message for the multicast stream. The switch CPU sends a MAC-based general query through the receiver port VLAN. If there is another set-top box in the VLAN still subscribing to this group, that set-top box must respond within the maximum response time specified in the query. If the CPU does not receive a response, it eliminates the receiver port as a forwarding destination for this group.

If the Immediate-Leave feature is enabled on a receiver port, the port leaves a multicast group more quickly. Without Immediate Leave, when the switch receives an IGMP leave message from a subscriber on a receiver port, it sends out an IGMP query on that port and waits for IGMP group membership reports. If no reports are received in a configured time period, the receiver port is removed from multicast group membership. With Immediate Leave, an IGMP query is not sent from the receiver port on which the IGMP leave was received. As soon as the leave message is received, the receiver port is removed from multicast group membership, which speeds up leave latency. Enable the Immediate Leave feature only on receiver ports to which a single receiver device is connected.

MVR eliminates the need to duplicate television-channel multicast traffic for subscribers in each VLAN. Multicast traffic for all channels is only sent around the VLAN trunk once—only on the multicast VLAN. The IGMP leave and join messages are in the VLAN to which the subscriber port is assigned. These messages dynamically register for streams of multicast traffic in the multicast VLAN on the Layer 3 device. The access layer switch (S1 switch) modifies the forwarding behavior to allow the traffic to be forwarded from the multicast VLAN to the subscriber port in a different VLAN, selectively allowing traffic to cross between two VLANs.

IGMP reports are sent to the same IP multicast group address as the multicast data. The S1 CPU must capture all IGMP join and leave messages from receiver ports and forward them to the multicast VLAN of the source (uplink) port, based on the MVR mode.

## Configuring MVR

These sections include basic MVR configuration information:

- [Default MVR Configuration, page 15-14](#)
- [MVR Configuration Guidelines and Limitations, page 15-15](#)
- [Configuring MVR Global Parameters, page 15-15](#)
- [Configuring MVR Interfaces, page 15-17](#)

## Default MVR Configuration

[Table 15-5](#) shows the default MVR configuration.

**Table 15-5 Default MVR Configuration**

Feature	Default Setting
MVR	Disabled globally and per interface
Multicast addresses	None configured
Query response time	0.5 second
Multicast VLAN	VLAN 1
Mode	Compatible

**Table 15-5 Default MVR Configuration (continued)**

Feature	Default Setting
Interface (per port) default	Neither a receiver nor a source port
Immediate Leave	Disabled on all ports

## MVR Configuration Guidelines and Limitations

Follow these guidelines when configuring MVR:

- Receiver ports can only be access ports; they cannot be trunk ports. Receiver ports on a switch can be in different VLANs, but should not belong to the multicast VLAN.
- The maximum number of multicast entries (MVR group addresses) that can be configured on a switch (that is, the maximum number of television channels that can be received) is 256.
- MVR multicast data received in the source VLAN and leaving from receiver ports has its time-to-live (TTL) decremented by 1 in the Catalyst 3750 switch.
- Because MVR on the Catalyst 3750 switch uses IP multicast addresses instead of MAC multicast addresses, aliased IP multicast addresses are allowed on the switch. However, if the switch is interoperating with Catalyst 3550 or Catalyst 3500 XL switches, you should not configure IP addresses that alias between themselves or with the reserved IP multicast addresses (in the range 224.0.0.xxx).
- MVR is not supported when multicast routing is enabled on a switch. If you enable multicast routing and a multicast routing protocol while MVR is enabled, MVR is disabled, and you receive a warning message. If you try to enable MVR while multicast routing and a multicast routing protocol are enabled, the operation to enable MVR is cancelled, and you receive an error message.
- MVR can coexist with IGMP snooping on a switch.
- MVR data received on an MVR receiver port is not forwarded to MVR source ports.

## Configuring MVR Global Parameters

You do not need to set the optional MVR parameters if you choose to use the default settings. If you do want to change the default parameters (except for the MVR VLAN), you must first enable MVR.



### Note

For complete syntax and usage information for the commands used in this section, refer to the command reference for this release.

Beginning in privileged EXEC mode, follow these steps to configure MVR parameters:

	Command	Purpose
Step 1	<code>configure terminal</code>	Enter global configuration mode.
Step 2	<code>mvr</code>	Enable MVR on the switch.

	Command	Purpose
Step 3	<b>mvr group</b> <i>ip-address</i> [ <i>count</i> ]	Configure an IP multicast address on the switch or use the <i>count</i> parameter to configure a contiguous series of MVR group addresses (the range for <i>count</i> is 1 to 256; the default is 1). Any multicast data sent to this address is sent to all source ports on the switch and all receiver ports that have elected to receive data on that multicast address. Each multicast address would correspond to one television channel.
Step 4	<b>mvr querytime</b> <i>value</i>	(Optional) Define the maximum time to wait for IGMP report memberships on a receiver port before removing the port from multicast group membership. The value is in units of tenths of a second. The range is from 1 to 100 and the default is 5 tenths or one-half second.
Step 5	<b>mvr vlan</b> <i>vlan-id</i>	(Optional) Specify the VLAN in which multicast data is received; all source ports must belong to this VLAN. The VLAN range is 1 to 4094. The default is VLAN 1.
Step 6	<b>mvr mode</b> { <b>dynamic</b>   <b>compatible</b> }	(Optional) Specify the MVR mode of operation: <ul style="list-style-type: none"> <li>• <b>dynamic</b>—Allows dynamic MVR membership on source ports.</li> <li>• <b>compatible</b>—Is compatible with Catalyst 3500 XL and Catalyst 2900 XL switches and does not support IGMP dynamic joins on source ports.</li> </ul> The default is <b>compatible</b> mode.
Step 7	<b>end</b>	Return to privileged EXEC mode.
Step 8	<b>show mvr</b> or <b>show mvr members</b>	Verify the configuration.
Step 9	<b>copy running-config startup-config</b>	(Optional) Save your entries in the configuration file.

To return the switch to its default settings, use the **no mvr [mode | group ip-address | querytime | vlan]** global configuration commands.

This example shows how to enable MVR, configure the group address, set the query time to 1 second (10 tenths), specify the MVR multicast VLAN as VLAN 22, and set the MVR mode as dynamic:

```
Switch(config)# mvr
Switch(config)# mvr group 228.1.23.4
Switch(config)# mvr querytime 10
Switch(config)# mvr vlan 22
Switch(config)# mvr mode dynamic
Switch(config)# end
```

You can use the **show mvr members** privileged EXEC command to verify the MVR multicast group addresses on the switch.

## Configuring MVR Interfaces

Beginning in privileged EXEC mode, follow these steps to configure Layer 2 MVR interfaces:

	Command	Purpose
Step 1	<b>configure terminal</b>	Enter global configuration mode.
Step 2	<b>mvr</b>	Enable MVR on the switch.
Step 3	<b>interface</b> <i>interface-id</i>	Enter interface configuration mode, and enter the type and number of the Layer 2 port to configure.
Step 4	<b>mvr type</b> {source   receiver}	<p>Configure an MVR port as one of these:</p> <ul style="list-style-type: none"> <li>• <b>source</b>—Configure uplink ports that receive and send multicast data as source ports. Subscribers cannot be directly connected to source ports. All source ports on a switch belong to the single multicast VLAN.</li> <li>• <b>receiver</b>—Configure a port as a receiver port if it is a subscriber port and should only receive multicast data. It does not receive data unless it becomes a member of the multicast group, either statically or by using IGMP leave and join messages. Receiver ports cannot belong to the multicast VLAN.</li> </ul> <p>The default configuration is as a non-MVR port. If you attempt to configure a non-MVR port with MVR characteristics, the operation fails.</p>
Step 5	<b>mvr vlan</b> <i>vlan-id</i> <b>group</b> [ <i>ip-address</i> ]	<p>(Optional) Statically configure a port to receive multicast traffic sent to the multicast VLAN and the IP multicast address. A port statically configured as a member of a group remains a member of the group until statically removed.</p> <p><b>Note</b> In compatible mode, this command applies to only receiver ports. In dynamic mode, it applies to receiver ports and source ports.</p> <p>Receiver ports can also dynamically join multicast groups by using IGMP join and leave messages.</p>
Step 6	<b>mvr immediate</b>	<p>(Optional) Enable the Immediate Leave feature of MVR on the port.</p> <p><b>Note</b> This command applies to only receiver ports and should only be enabled on receiver ports to which a single receiver device is connected.</p>
Step 7	<b>end</b>	Return to privileged EXEC mode.
Step 8	<b>show mvr</b>  <b>show mvr interface</b> or <b>show mvr members</b>	Verify the configuration.
Step 9	<b>copy running-config startup-config</b>	(Optional) Save your entries in the configuration file.

To return the interface to its default settings, use the **no mvr** [**type** | **immediate** | **vlan** *vlan-id* | **group**] interface configuration commands.

This example shows how to configure Gigabit Ethernet port 1/0/3 as a receiver port, statically configure the port to receive multicast traffic sent to the multicast group address, configure Immediate Leave on the interface, and verify the results.

```
Switch(config)# mvr
Switch(config)# interface gigabitethernet1/0/3
Switch(config-if)# mvr type receiver
Switch(config-if)# mvr vlan 22 group 228.1.23.4
Switch(config-if)# mvr immediate
Switch(config)# end
Switch# show mvr interface
Port      Type      Status      Immediate Leave
----      -
Gi1/0/3  RECEIVER  ACTIVE/DOWN  ENABLED
```

## Displaying MVR Information

You can display MVR information for the switch or for a specified interface. Beginning in privileged EXEC mode, use the commands in [Table 15-6](#) to display MVR configuration:

**Table 15-6** Commands for Displaying MVR Information

<b>show mvr</b>	Displays MVR status and values for the switch—whether MVR is enabled or disabled, the multicast VLAN, the maximum (256) and current (0 through 256) number of multicast groups, the query response time, and the MVR mode.
<b>show mvr interface</b> <i>[interface-id]</i> <b>[members [vlan vlan-id]]</b>	<p>Displays all MVR interfaces and their MVR configurations.</p> <p>When a specific interface is entered, displays this information:</p> <ul style="list-style-type: none"> <li>• Type—Receiver or Source</li> <li>• Status—One of these: <ul style="list-style-type: none"> <li>– Active means the port is part of a VLAN.</li> <li>– Up/Down means that the port is forwarding or nonforwarding.</li> <li>– Inactive means that the port is not part of any VLAN.</li> </ul> </li> <li>• Immediate Leave—Enabled or Disabled</li> </ul> <p>If the <b>members</b> keyword is entered, displays all multicast group members on this port or, if a VLAN identification is entered, all multicast group members on the VLAN. The VLAN ID range is 1 to 4094; do not enter leading zeros.</p>
<b>show mvr members</b> <i>[ip-address]</i>	Displays all receiver and source ports that are members of any IP multicast group or the specified IP multicast group IP address.

## Configuring IGMP Filtering

In some environments, for example metropolitan or multiple-dwelling unit (MDU) installations, an administrator might want to control the set of multicast groups to which a user on a switch port can belong. This allows the administrator to control the distribution of multicast services, such as IP/TV, based on some type of subscription or service plan. With the IGMP filtering feature, you can filter multicast joins on a per-port basis by configuring IP multicast profiles and associating them with individual switch ports. An IGMP profile can contain one or more multicast groups and specifies whether access to the group is permitted or denied. If an IGMP profile denying access to a multicast group is applied to a switch port, the IGMP join report requesting the stream of IP multicast traffic is dropped, and the port is not allowed to receive IP multicast traffic from that group. If the filtering action permits access to the multicast group, the IGMP report from the port is forwarded for normal processing.

IGMP filtering controls only group specific query and membership reports, including join and leave reports. It does not control general IGMP queries. IGMP filtering has no relationship with the function that directs the forwarding of IP multicast traffic. The filtering feature operates in the same manner whether CGMP or MVR is used to forward the multicast traffic.

IGMP filtering is only applicable to dynamic learning of IP multicast group addresses; not static configuration.

You can also set the maximum number of IGMP groups that a Layer 2 interface can join.

## Default IGMP Filtering Configuration

Table 15-7 shows the default IGMP filtering configuration.

**Table 15-7 Default IGMP Filtering Configuration**

Feature	Default Setting
IGMP filters	None applied
IGMP Maximum number of IGMP groups	No maximum set
IGMP profiles	None defined
IGMP profile action	Deny the range addresses

## Configuring IGMP Profiles

To configure an IGMP profile, use the **ip igmp profile** global configuration command with a profile number to create an IGMP profile and to enter IGMP profile configuration mode. From this mode, you can specify the parameters of the IGMP profile to be used for filtering IGMP join requests from a port. When you are in IGMP profile configuration mode, you can create the profile by using these commands:

- **deny**: Specifies that matching addresses are denied; this is the default condition.
- **exit**: Exits from igmp-profile configuration mode.
- **no**: Negates a command or sets its defaults.
- **permit**: Specifies that matching addresses are permitted.
- **range**: Specifies a range of IP addresses for the profile. You can enter a single IP address or a range with a start and an end address.

The default is for the switch to have no IGMP profiles configured. When a profile is configured, if neither the **permit** nor **deny** keyword is included, the default is to deny access to the range of IP addresses.

Beginning in privileged EXEC mode, follow these steps to create an IGMP profile:

	Command	Purpose
Step 1	<b>configure terminal</b>	Enter global configuration mode.
Step 2	<b>ip igmp profile</b> <i>profile number</i>	Enter IGMP profile configuration mode, and assign a number to the profile you are configuring. The range is from 1 to 4294967295.
Step 3	<b>permit   deny</b>	(Optional) Set the action to permit or deny access to the IP multicast address. If no action is configured, the default for the profile is to deny access.
Step 4	<b>range</b> <i>ip multicast address</i>	Enter the IP multicast address or range of IP multicast addresses to which access is being controlled. If entering a range, enter the low IP multicast address, a space, and the high IP multicast address.  You can use the <b>range</b> command multiple times to enter multiple addresses or ranges of addresses.
Step 5	<b>end</b>	Return to privileged EXEC mode.
Step 6	<b>show ip igmp profile</b> <i>profile number</i>	Verify the profile configuration.
Step 7	<b>copy running-config startup-config</b>	(Optional) Save your entries in the configuration file.

To delete a profile, use the **no ip igmp profile** *profile number* global configuration command.

To delete an IP multicast address or range of IP multicast addresses, use the **no range** *ip multicast address* IGMP profile configuration command.

This example shows how to create IGMP profile 4 allowing access to the single IP multicast address and how to verify the configuration. If the action was to deny (the default), it would not appear in the **show ip igmp profile** output display.

```
Switch(config)# ip igmp profile 4
Switch(config-igmp-profile)# permit
Switch(config-igmp-profile)# range 229.9.9.0
Switch(config-igmp-profile)# end
Switch# show ip igmp profile 4
IGMP Profile 4
    permit
    range 229.9.9.0 229.9.9.0
```

## Applying IGMP Profiles

To control access as defined in an IGMP profile, use the **ip igmp filter** interface configuration command to apply the profile to the appropriate interfaces. You can apply IGMP profiles to layer 2 access ports only; you cannot apply IGMP profiles to routed ports or SVIs. You cannot apply profiles to ports that belong to an EtherChannel port group. You can apply a profile to multiple interfaces, but each interface can only have one profile applied to it.

Beginning in privileged EXEC mode, follow these steps to apply an IGMP profile to a switch port:

	Command	Purpose
Step 1	<b>configure terminal</b>	Enter global configuration mode.
Step 2	<b>interface</b> <i>interface-id</i>	Enter interface configuration mode, and enter the physical interface to configure. The interface must be a Layer 2 port that does not belong to an EtherChannel port group.
Step 3	<b>ip igmp filter</b> <i>profile number</i>	Apply the specified IGMP profile to the interface. The profile number can be from 1 to 4294967295.
Step 4	<b>end</b>	Return to privileged EXEC mode.
Step 5	<b>show running-config interface</b> <i>interface-id</i>	Verify the configuration.
Step 6	<b>copy running-config startup-config</b>	(Optional) Save your entries in the configuration file.

To remove a profile from an interface, use the **no ip igmp filter** *profile number* interface configuration command.

This example shows how to apply IGMP profile 4 to an interface:

```
Switch(config)# interface gigabitEthernet1/0/12
Switch(config-if)# ip igmp filter 4
Switch(config-if)# end
```

## Setting the Maximum Number of IGMP Groups

You can set the maximum number of IGMP groups that a Layer 2 interface can join by using the **ip igmp mac-groups** interface configuration command. Use the **no** form of this command to set the maximum back to the default, which is no limit.

This restriction can be applied to Layer 2 ports only; you cannot set a maximum number of IGMP groups on routed ports or SVIs. You also cannot use this command on ports that belong to an EtherChannel port group.

Beginning in privileged EXEC mode, follow these steps to apply an IGMP profile to a switch port:

	Command	Purpose
Step 1	<b>configure terminal</b>	Enter global configuration mode.
Step 2	<b>interface</b> <i>interface-id</i>	Enter interface configuration mode, and enter the physical interface to configure. The interface must be a Layer 2 port that does not belong to an EtherChannel group.
Step 3	<b>ip igmp max-groups</b> <i>number</i>	Set the maximum number of IGMP groups that the interface can join. The range is from 0 to 4294967294. The default is to have no maximum set.
Step 4	<b>end</b>	Return to privileged EXEC mode.
Step 5	<b>show running-config interface</b> <i>interface-id</i>	Verify the configuration.
Step 6	<b>copy running-config startup-config</b>	(Optional) Save your entries in the configuration file.

To remove the maximum group limitation and return to the default of no maximum, use the **no ip igmp max-groups** interface configuration command.

This example shows how to limit the number of IGMP groups that an interface can join to 25.

```
Switch(config)# interface gigabitethernet1/0/12
Switch(config-if)# ip igmp max-groups 25
Switch(config-if)# end
```

## Displaying IGMP Filtering Configuration

You can display IGMP profile characteristics, and you can display the IGMP profile and maximum group configuration for all interfaces on the switch or for a specified interface.

Use the privileged EXEC commands in [Table 15-8](#) to display IGMP filtering configuration:

**Table 15-8** Commands for Displaying IGMP Filtering Configuration

<b>show ip igmp profile</b> [ <i>profile number</i> ]	Displays the specified IGMP profile or all IGMP profiles defined on the switch.
<b>show running-config</b> [ <b>interface interface-id</b> ]	Displays the configuration of the specified interface or all interfaces on the switch, including (if configured) the maximum number of IGMP groups to which an interface can belong and the IGMP profile applied to the interface.