



Installing ONS 15454 SDH TCC-I Cards

Product Name: 15454E-TCC-I=

This document contains a description of TCC-I card features, installation procedures, removal instructions, and technical specifications. Use this document in conjunction with the *Cisco ONS 15454 SDH Installation and Operations Guide* and the *Cisco ONS 15454 SDH Troubleshooting and Reference Guide* when working with TCC-I cards.

This document contains the following sections:

- [“TCC-I Timing Communication and Control Card Description” section on page 2](#)
- [“TCC-I Card Specifications” section on page 5](#)
- [“Installation Procedures” section on page 6](#)
- [“Removal Procedures” section on page 7](#)
- [“Related Documentation” section on page 9](#)
- [“Obtaining Documentation and Submitting a Service Request” section on page 10](#)

This document contains the following procedures:

[“Installation Procedures” procedure on page 6](#)

[“Card Turn Up” procedure on page 7](#)

[“Verify Successful Turn Up of the TCC-I Card” procedure on page 7](#)

[“Removal Procedures” procedure on page 7](#)

[“Initiate a Software Reset” procedure on page 8](#)



Note

For information about circuits and card capacities, see the *Cisco ONS 15454 SDH Installation and Operations Guide*.

TCC-I Timing Communication and Control Card Description

The TCC-I performs system initialization, provisioning, alarm reporting, maintenance, diagnostics, IP address detection/resolution, SDH SOH Data Communications Channel (DCC) termination, and system fault detection for the ONS 15454 SDH. The TCC-I also ensures that the system maintains Stratum 3 E (G.813) timing requirements. [Figure 1](#) shows the TCC-I faceplate and [Figure 2](#) shows a block diagram of the card.

Figure 1 TCC-I faceplate

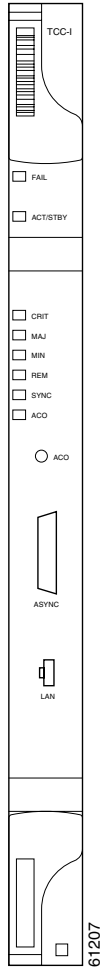

Install TCC-I cards in Slots 7 and 11 for redundancy. If the active TCC-I fails, traffic switches to the protect TCC-I. All TCC-I protection switches conform to protection switching standards when the BER counts are not in excess of 1×10^{-3} and completion time is less than 50 ms.

The TCC-I uses a 10Base-T LAN port for user interfaces, being led via the back plane to the port accessible on the front panel of the MIC-C/T/P unit.



Note

Cisco does not support operating the ONS 15454 SDH with only one TCC-I card. For full functionality and to safeguard your system, always operate in a redundant configuration.



Note

CTC software does not monitor for the presence or absence of FMECs unless the TCC-I(s) card has reached the active/standby state. During transitional states such as power-up or TCC-I reset CTC ignores the FMEC inventory displayed in node view.



Note

When a second TCC-I card is inserted into the shelf, it will synchronize its software, its backup software, and its database with the active TCC-I.
 If its software version does not match the version on the active TCC-I, the newly inserted TCC-I will copy from the active TCC-I. This copying will take about 15 to 20 minutes.
 If its backup software version does not match the version on the active TCC-I, the newly inserted TCC-I will copy the backup software from the active TCC-I. This copying, again, will take about 15 to 20 minutes.
 Copying the database from the active TCC-I will take about 3 minutes.
 So, depending on the software existing in the new TCC-I, booting it up will take between 3 and about 40 minutes.

TCC-I Card-Level Indicators

The TCC-I faceplate has eight LEDs. The first two LEDs are card-level indicators.

Table 1 TCC-I Card-Level Indicators

Card-Level LEDs	Definition
Red FAIL LED	This LED is lit during Reset. The FAIL LED flashes during the boot and write process. Replace the unit if the FAIL LED persists.
ACT/STBY LED Green (Active) Yellow (Standby)	The ACT/STBY (Active/Standby) LED indicates the TCC-I is active (green) or in standby (yellow). The ACT/STBY LED also provides the timing reference and shelf control. When the TCC-I is writing to the Active or Standby TCC-I, its Active or Standby LED will blink. Do not pull the TCC-I out during this time to avoid memory corruption.

Network-Level Indicators

The TCC-I faceplate has eight LEDs. Six LEDs are network-level indicators.

Table 2 TCC-I System-Level Indicators

System-Level LEDs	Definition
Red CRIT LED	Used to indicate critical alarms in the network at the local terminal.
Red MAJ LED	Used to indicate major alarms in the network at the local terminal.
Yellow MIN LED	Used to indicate a minor alarm in the network at the local terminal.
Red REM LED	Provides first-level alarm isolation. The REM LED turns red when an alarm is present in one or several of the remote terminals.
Green SYNC LED	Used to indicate that node timing is synchronized to an external reference.
Green ACO LED	After pressing the alarm cutoff (ACO) button, the green ACO LED illuminates. The ACO button opens the audible closure on the backplane. ACO state is stopped if a new alarm occurs. After the originating alarm is extinguished, the ACO LED and audible alarm control are reset.

TCC-I Card Specifications

- CTC Software
 - Interface: 10 Base-T LAN (via back plane)
 - Access: on the MIC-A/P unit
- Synchronization
 - Stratum 3 E, per ITU-T G.813
 - Free running access: accuracy ± 4.6 ppm
 - Holdover Stability: $3.7 * 10^{-7}$ /day including temperature (<255 slips in first 24 hours)
 - Reference: External BITS, line, internal
- Environmental
 - Operating Temperature: -5 to +45 degrees Celsius
 - Operating Humidity: 5 - 95%, non-condensing
 - Power Consumption: 9.82 W, 0.20 A (AMPS) @ -48V, 33.5 BTU/Hr.
- Dimensions
 - Height: 321.3 mm, (12.650 in.)
 - Width: 18.2 mm, (0.716 in.)
 - Depth: 228.6 mm, (9.000 in.)
 - Depth with backplane connector: 235 mm, (9.250 in.)
 - Weight not including clam shell: 0.7 kg (1.5 lbs.)
- Compliance

ONS15454 SDH cards, when installed in a system, comply with these standards:

 - Safety: IEC 60950, EN 60950, UL 60950, CSA C22.2 No. 60950, TS 001, AS/NZS 3260

Installation Procedures

Use this section if you are installing or removing the TCC-I card for the first time. After you become familiar with ONS 15454 SDH card installation and boot up, use this section as a reference.

Caution

Always use the supplied electrostatic discharge (ESD) wristband when working with an ONS 15454 SDH. Plug the wristband cable into the ESD jack located on the lower right outside edge of the shelf assembly and ensure the shelf assembly is properly grounded.

Caution

Hazardous voltage or energy may be present on the backplane when the system is operating. Use caution when servicing.

- Step 1** Open the card ejectors.
- Step 2** Carefully insert the card into the guide rails of the desired slot ([Figure 3 on page 6](#)). The TCC-I card has to be inserted into slot 7 or slot 11.
- Step 3** Push the card into the connector on the back plane by closing the ejectors.

Figure 3 *Installing cards in an ONS 15454 SDH*

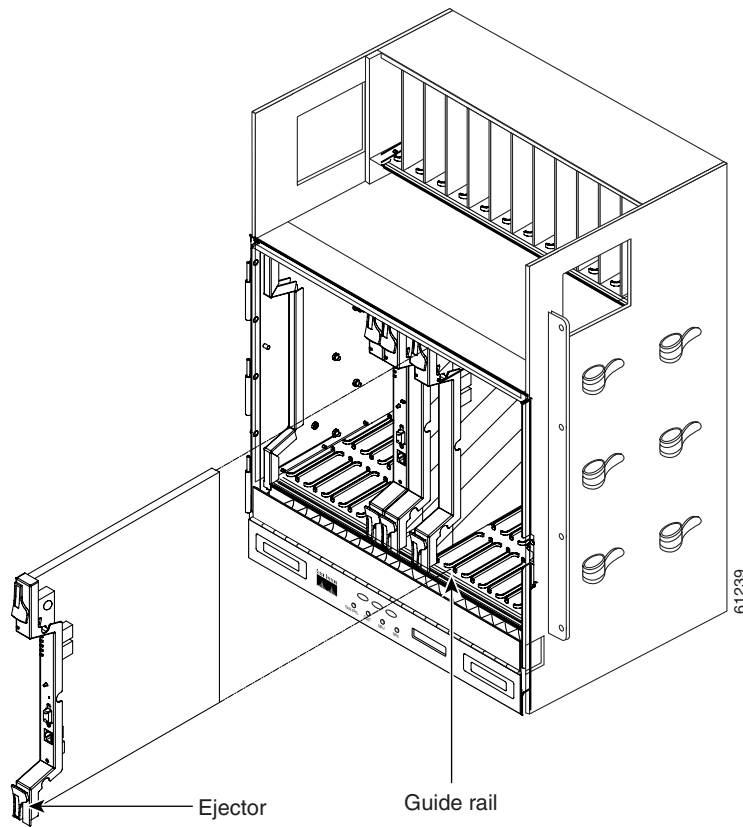

Card Turn Up

Follow the steps in this section to verify card turn up. If one or more of the Cisco Transport Controller (CTC) software screen conditions according to “[Verify Successful Turn Up of the TCC-I Card](#)” section on page 7 are not met, re-install the card. Replace the unit if the faulty state persists.

Verify Successful Turn Up of the TCC-I Card

Step 1 Verify that power is applied to the shelf assembly.

Step 2 Verify that the TCC-I card has been installed in the correct slot (Slot 7 or slot 11).



Note The TCC-I card takes several minutes to reboot and display the amber standby LED after rebooting.



Note When a second TCC-I card is inserted into the shelf, it will synchronize its software, its backup software, and its database with the active TCC-I.
 If its software version does not match the version on the active TCC-I, the newly inserted TCC-I will copy from the active TCC-I. This copying will take about 15 to 20 minutes.
 If its backup software version does not match the version on the active TCC-I, the newly inserted TCC-I will copy the backup software from the active TCC-I. This copying, again, will take about 15 to 20 minutes.
 Copying the database from the active TCC-I will take about 3 minutes.
 So, depending on the software existing in the new TCC-I, booting it up will take between 3 and about 40 minutes.

Step 3 Verify that the card appears in the correct slot on the CTC software screen.

Step 4 Verify that the card is white on the CTC software screen.

Step 5 Verify that the card is shown in Inventory on the CTC software screen.

Removal Procedures

Use this section if you are installing or removing the TCC-I card for the first time. After you become familiar with ONS 15454 SDH card installation and boot up, use this section as a reference.



Caution

Always use the supplied electrostatic discharge (ESD) wristband when working with an ONS 15454 SDH. Plug the wristband cable into the ESD jack located on the lower right outside edge of the shelf assembly and ensure the shelf assembly is properly grounded.



Caution

Hazardous voltage or energy may be present on the backplane when the system is operating. Use caution when servicing.



Note

To determine whether the TCC-I card is in active mode or standby mode, view it in the CTC software and position the cursor over the TCC-I card graphic to display the status.

- Step 1** If you need to perform a card pull on an active TCC-I card, initiate a software reset on the active TCC-I card first. (See the [“Initiate a Software Reset”](#) section on page 8).
- Step 2** When the TCC-I is in standby mode, unlatch the top and bottom ejector levers on the TCC-I card.
- Step 3** Carefully remove the card from the shelf.

Initiate a Software Reset

- Step 1** Log into the CTC software.
- Step 2** Right-click the TCC-I card to reveal a pull-down menu.
- Step 3** Click **Reset Card**. (See [Figure 4](#)).

Figure 4 Resetting from the TCC-I card pull-down menu

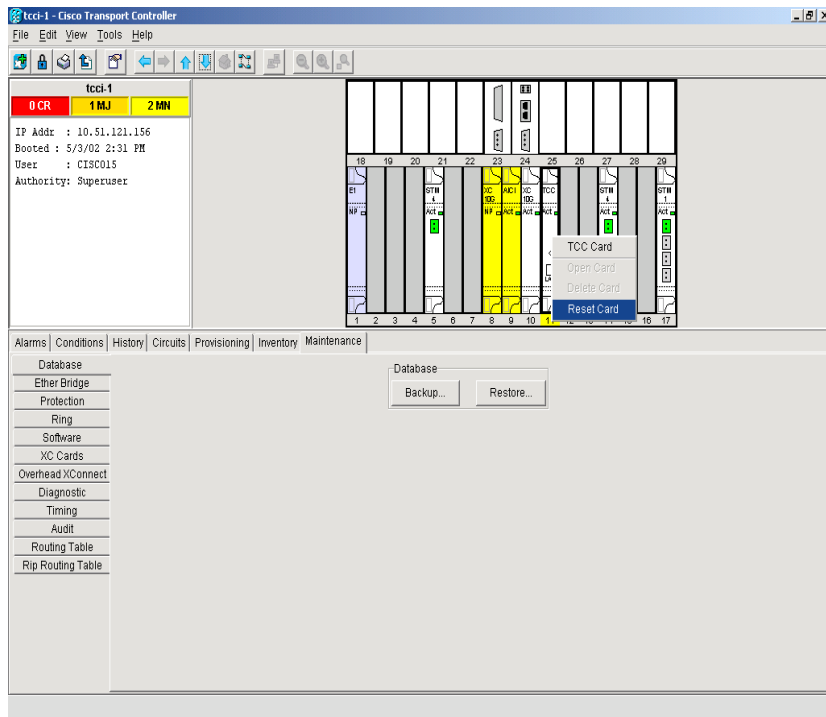

- Step 4** Click **Yes** in the dialog box when the "Are You Sure?" prompt appears.
- Step 5** Click **OK** in the dialog box when the "Lost connection to node, changing to Network View" prompt appears.
- Step 6** Confirm that the TCC-I card is in standby mode after the reset.

Related Documentation

- DOC-7813038= *Cisco ONS 15454 SDH Installation and Operations Guide*
- DOC-7813037= *Cisco ONS 15454 SDH Troubleshooting and Reference Guide*

Obtaining Documentation and Submitting a Service Request

For information on obtaining documentation, submitting a service request, and gathering additional information, see the monthly *What's New in Cisco Product Documentation*, which also lists all new and revised Cisco technical documentation, at:

<http://www.cisco.com/en/US/docs/general/whatsnew/whatsnew.html>

Subscribe to the *What's New in Cisco Product Documentation* as a Really Simple Syndication (RSS) feed and set content to be delivered directly to your desktop using a reader application. The RSS feeds are a free service and Cisco currently supports RSS version 2.0.

This document is to be used in conjunction with the documents listed in the "Related Documentation" section.

CCVP, the Cisco logo, and Welcome to the Human Network are trademarks of Cisco Systems, Inc.; Changing the Way We Work, Live, Play, and Learn is a service mark of Cisco Systems, Inc.; and Access Registrar, Aironet, Catalyst, CCDA, CCDP, CCIE, CCIP, CCNA, CCNP, CCSP, Cisco, the Cisco Certified Internetwork Expert logo, Cisco IOS, Cisco Press, Cisco Systems, Cisco Systems Capital, the Cisco Systems logo, Cisco Unity, Enterprise/Solver, EtherChannel, EtherFast, EtherSwitch, Fast Step, Follow Me Browsing, FormShare, GigaDrive, HomeLink, Internet Quotient, IOS, iPhone, IP/TV, iQ Expertise, the iQ logo, iQ Net Readiness Scorecard, iQuick Study, LightStream, Linksys, MeetingPlace, MGX, Networkers, Networking Academy, Network Registrar, PIX, ProConnect, ScriptShare, SMARTnet, StackWise, The Fastest Way to Increase Your Internet Quotient, and TransPath are registered trademarks of Cisco Systems, Inc. and/or its affiliates in the United States and certain other countries.

All other trademarks mentioned in this document or Website are the property of their respective owners. The use of the word partner does not imply a partnership relationship between Cisco and any other company. (0711R)

Copyright © 2002, Cisco Systems, Inc.
All rights reserved.