



Installing ONS 15454 SDH OC3 IR 4/STM1 SH 1310 Cards

Product Name: 15454E-S1.1-4=

This document contains a description of OC3 IR 4/STM1 SH 1310 card features, installation procedures, removal instructions, and technical specifications. Use this document in conjunction with the *Cisco ONS 15454 SDH Installation and Operations Guide* and the *Cisco ONS 15454 SDH Troubleshooting and Reference Guide* when working with OC3 IR 4/STM1 SH 1310 cards.

This document contains the following sections:

- “Installation Procedures” section on page 5
- “OC3 IR 4/STM1 SH 1310 Card Specifications” section on page 4
- “Installation Procedures” section on page 5
- “Removal Procedures” section on page 7
- “Related Documentation” section on page 8
- “Obtaining Documentation and Submitting a Service Request” section on page 9

This document contains the following procedures:

- “Installation Procedures” procedure on page 5
- “Card Turn Up” procedure on page 6
- “Verify Successful Turn Up of the OC3 IR 4/STM1 SH 1310 Card” procedure on page 6
- “Removal Procedures” procedure on page 7
- “Reset an STM-N Card” procedure on page 7



Note

For information about circuits and card capacities, see the *Cisco ONS 15454 SDH Installation and Operations Guide*.



Americas Headquarters:
Cisco Systems, Inc., 170 West Tasman Drive, San Jose, CA 95134-1706 USA

OC3 IR 4/STM1 SH 1310 Card

The OC3 IR 4/STM1 SH 1310 card provides four intermediate or short range, ITU-T G.707-, ITU-T G.957- compliant, SDH STM-1 ports. Each port operates at 155.52 MBits/s (Mbps) over a single-mode fiber span. The card supports concatenated or non-concatenated payloads at the STM-1 signal level on a per VC-4 basis. [Figure 1](#) shows the OC3 IR 4/STM1 SH 1310 faceplate and [Figure 2](#) shows a block diagram of the card.



Warning

Class 1 laser product.

Figure 1 OC3 IR 4/STM1 SH 1310 faceplate

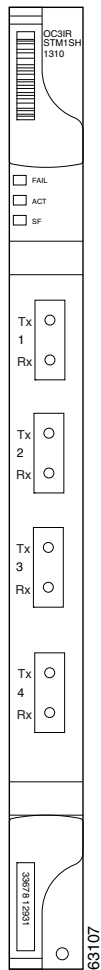

You can install the OC3 IR 4/STM1 SH 1310 card in any multispeed or high-speed card slot. The card can be provisioned as part of a SNCP or in an Add/drop multiplexer/terminal monitor (ADM/TM) configuration. Each interface features a 1310 nm laser and contains a transmit and receive connector (labeled) on the card faceplate. The card uses SC connectors.

The OC3 IR 4/STM1 SH 1310 card supports 1+1 unidirectional and bidirectional protection switching. You can provision protection on a per port basis.

The OC3 IR 4/STM1 SH 1310 detects LOS, LOF, Loss of Pointer (LOP), Multiplex Section Alarm Indication Signal (MS-AIS), and Multiplex Section Far End Receive Failure (MS-FERF) conditions. Refer to [Chapter 1, “Alarm Troubleshooting,”](#) of the *“Cisco ONS 15454 SDH Troubleshooting and Maintenance Guide, R3.3”* for a description of these conditions. The card also counts section and line bit interleaved parity (BIP) errors.

To enable automatic protection switching (APS), the OC3 IR 4/STM1 SH 1310 extracts the K1 and K2 bytes from the SDH overhead to perform appropriate protection switches. The DCC bytes are forwarded to the TCC-I, which terminates the DCC.

OC3 IR 4/STM1 SH 1310 Card-Level Indicators

The OC3 IR 4/STM1 SH 1310 card has three card-level LED indicators.

Table 1 OC3 IR 4/STM1 SH 1310 Card-Level Indicators

Card-Level LEDs	Description
Red FAIL LED	The red FAIL LED indicates the card’s processor is not ready. This LED is lit during Reset. The FAIL LED flashes during the boot process. Replace the card if the red FAIL LED persists.
Green ACT LED	The green ACT LED indicates the OC3 IR 4/STM1 SH 1310 card is carrying traffic or is traffic-ready.
Yellow SF LED	The yellow SF LED indicates a signal failure or condition such as LOS, LOF, MS-AIS or high BER on one or more of the card’s ports. The Yellow SF LED also illuminates when the transmit and receive fibers are incorrectly connected. When the fibers are properly connected and the links are working, the light turns off.

OC3 IR 4/STM1 SH 1310 Port-Level Indicators

You can find the status of the four card ports using the LCD screen on the ONS 15454 SDH fan tray assembly. Use the LCD to view the status of any port or card slot; the screen displays the number and severity of alarms for a given port or slot. Refer to the *“Cisco ONS 15454 SDH Installation and Operations Guide, R3.3”* for a complete description of the alarm messages.

Figure 2 OC3 IR 4/STM1 SH 1310 block diagram

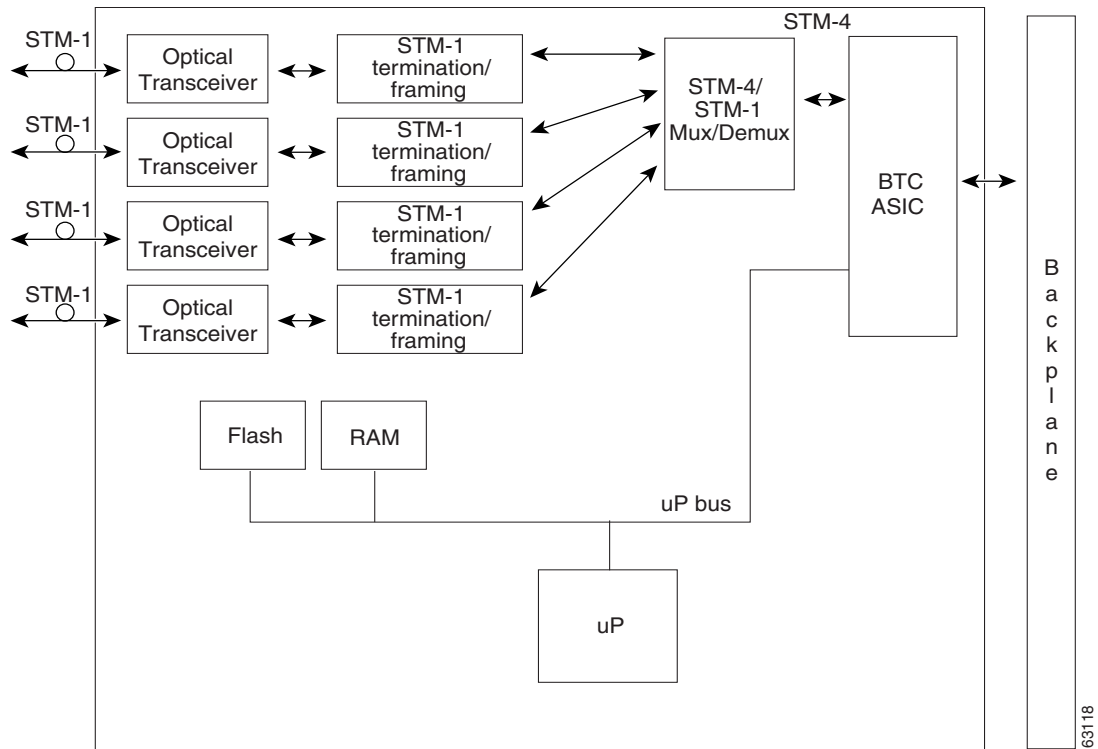

Warning

Invisible laser radiation may be emitted from disconnected fibers or connectors. Do not stare into beams or view directly with optical instruments.

OC3 IR 4/STM1 SH 1310 Card Specifications

- Line
 - Bit Rate: 155.52 Mbits/s (Mbps)
 - Code: Scrambled NRZ
 - Fiber: 1310 nm single-mode
 - Loopback Modes: Terminal and Facility
 - Connector: SC
 - Compliance: ITU-T G.707, ITU-T G.957
- Transmitter
 - Max. Transmitter Output Power: -8 dBm
 - Min. Transmitter Output Power: -15 dBm
 - Center Wavelength: 1293 nm – 1334 nm
 - Nominal Wavelength: 1310 nm
 - Transmitter: Fabry Perot laser

- Receiver
 - Max. Receiver Level: -8 dBm at BER $1 * 10^{-10}$
 - Min. Receiver Level: -28 dBm at BER $1 * 10^{-10}$
 - Receiver: InGaAs/InP photo detector
 - Link Loss Budget: 13 dB
- Environmental
 - Operating Temperature: -5 to +45 degrees Celsius
 - Operating Humidity: 5 to 95%, non-condensing
 - Power Consumption: 19.20 W, 0.40 A (AMPS) at -48V, 65.6 BTU/hr
- Dimensions
 - Height: 321.3 mm (12.650 in.)
 - Width: 18.2 mm (0.716 in.)
 - Depth: 228.6 mm (9.000 in.)
 - Depth with backplane connector: 235 mm (9.250 in.)
 - Weight not including clam shell: 0.4 kg (1.0 lb)
- Compliance

ONS15454 SDH optical cards, when installed in a system, comply with these standards:

 - Safety: IEC 60950, EN 60950, UL 60950, CSA C22.2 No. 60950, TS 001, AS/NZS 3260, IEC 60825-1, IEC 60825-2, 21 CFR 1040-10 and 21 CFR 1040.11.
 - Class 1 laser product

Installation Procedures

Use this section if you are installing or removing the OC3 IR 4/STM1 SH 1310 card for the first time. After you become familiar with ONS 15454 SDH card installation and boot up, use this section as a reference.



Caution

Always use the supplied electrostatic discharge (ESD) wristband when working with an ONS 15454 SDH. Plug the wristband cable into the ESD jack located on the lower right outside edge of the shelf assembly and ensure the shelf assembly is properly grounded.



Caution

Hazardous voltage or energy may be present on the backplane when the system is operating. Use caution when servicing.

- Step 1** Open the card ejectors.
- Step 2** Carefully insert the card into the guide rails of the desired slot ([Figure 3 on page 6](#)).
- Step 3** Push the card into the connector on the back plane by closing the ejectors.

Figure 3 *Installing cards in an ONS 15454 SDH*

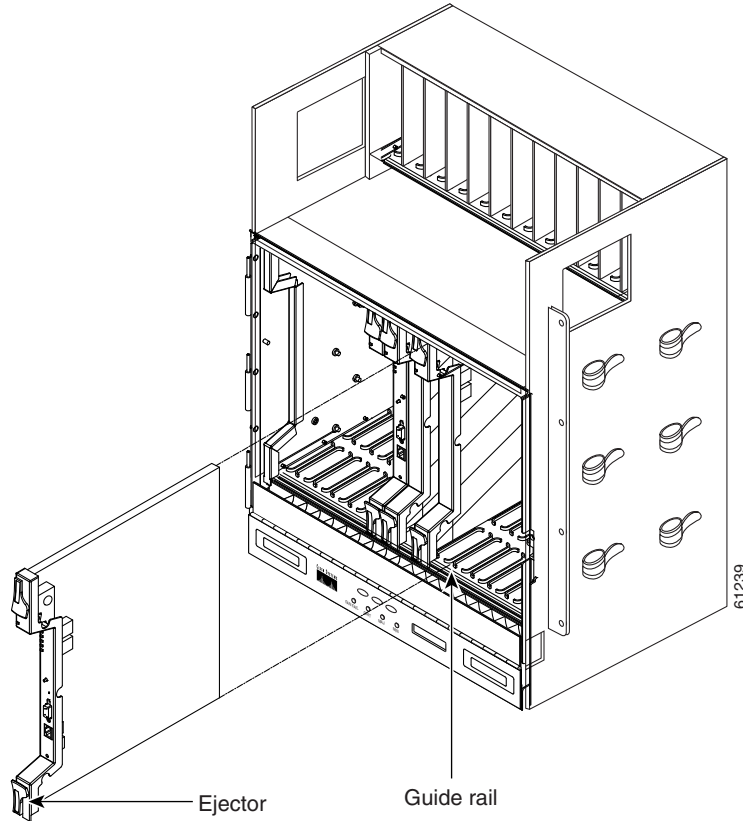

Card Turn Up

Follow the steps in this section to verify card turn up. If one or more of the Cisco Transport Controller (CTC) software screen conditions according to [“Verify Successful Turn Up of the OC3 IR 4/STM1 SH 1310 Card”](#) section on page 6 are not met, re-install the card. Replace the unit if the faulty state persists.

Verify Successful Turn Up of the OC3 IR 4/STM1 SH 1310 Card

-
- Step 1** Verify that power is applied to the shelf assembly.
 - Step 2** Verify that the OC3 IR 4/STM1 SH 1310 card has been installed in the correct slot.
 - Step 3** Verify that the card appears in the correct slot on the CTC software screen.
 - Step 4** Verify that the card is white on the CTC software screen.
 - Step 5** Verify that the card is shown in Inventory on the CTC software screen.
-

Removal Procedures

Use this section if you are installing or removing the OC3 IR 4/STM1 SH 1310 card for the first time. After you become familiar with ONS 15454 SDH card installation and boot up, use this section as a reference.



Caution

Always use the supplied electrostatic discharge (ESD) wristband when working with an ONS 15454 SDH. Plug the wristband cable into the ESD jack located on the lower right outside edge of the shelf assembly and ensure the shelf assembly is properly grounded.



Caution

Hazardous voltage or energy may be present on the backplane when the system is operating. Use caution when servicing.



Note

Traffic can be interrupted if you pull an active card from the ONS 15454 SDH. Use caution when replacing cards and verify that only inactive or standby cards are being replaced. If an active card needs to be replaced, follow the procedure to switch the electrical card to standby mode before you pull the card from the node.

Reset an STM-N Card



Note

An STM-N reset can cause a linear 1+1 STM-N protection switch or an MSSPRing protection switch.



Note

Traffic can be interrupted if you pull an active card from the ONS 15454 SDH. Use caution when replacing cards and verify that only inactive or standby cards are being replaced. If an active card needs to be replaced, follow the procedure to switch the STM-N card to standby mode before you pull the card from the node.



Warning

Class I (21 CFR 1040.10 and 1040.11) and Class 1M (IEC 60825-1 2001-01) laser products.



Warning

Invisible laser radiation may be emitted from the end of the unterminated fiber cable or connector. Do not stare into the beam or view directly with optical instruments. Viewing the laser output with certain optical instruments (for example, eye loupes, magnifiers, and microscopes) within a distance of 100 mm may pose an eye hazard. Use of controls or adjustments or performance of procedures other than those specified may result in hazardous radiation exposure.

The STM-N card should be replaced if a red FAIL LED appears.

Take these precautions before initiating an STM-N card reset to avoid causing a linear 1+1 or MSSPRing protection switch:

Step 1

Ensure that the working (active) span is active on the local and remote nodes.

- Step 2** Ensure that the working (active) span is carrying error-free traffic without FAIL alarms or SF alarms.
- Step 3** Perform a lockout on the protection span in the CTC software before initiating an STM-N card reset. In an MSSPRing, place a lockout on the East and West node cards adjacent to the XC10-G switch node. For example, if you are switching the XC10-G on Node B, place a lockout on the Node A West card and on the Node C East card. You do not need to place lockouts on Node B. Before setting the lockout, verify that the MSSPRing is not switched. Traffic can be lost if the MSSPRing is switched when the lockout is set.

<-----East [Node A] West-----East [Node B] West-----East [Node C] West----->

In a 1+1 protection scheme, place a lockout on the protect card and verify that traffic is traveling over the working span before setting the lockout.

Replace an In-Service STM-N Card



Caution

Hazardous voltage or energy may be present on the backplane when the system is operating. Use caution when servicing.

- Step 1** In the CTC software, determine which STM-N card is active.



Note

You can determine whether the card is in active mode or standby mode by viewing it in the CTC software and positioning the cursor over the card graphic to display the status.

- Step 2** Switch the active STM-N card to standby:
- a. In the node view, select the **Maintenance > STM Cards** tabs.
 - b. From the Cross Connect Cards menu, choose **Switch**.
 - c. Click **Yes** on the Confirm Switch dialog box.



Note

After the working STM-N card goes into protection, the protection slot becomes working. This causes the former working card ACT LED to switch off.

- Step 3** Pull the protection STM-N card from the ONS 15454 SDH.
- Step 4** Insert the replacement STM-N card into the empty slot. The replacement card boots up and becomes ready for service after approximately one minute. After this procedure the card is ready for protection function.

Related Documentation

- DOC-7813038= *Cisco ONS 15454 SDH Installation and Operations Guide*
- DOC-7813037= *Cisco ONS 15454 SDH Troubleshooting and Reference Guide*

Obtaining Documentation and Submitting a Service Request

For information on obtaining documentation, submitting a service request, and gathering additional information, see the monthly *What's New in Cisco Product Documentation*, which also lists all new and revised Cisco technical documentation, at:

<http://www.cisco.com/en/US/docs/general/whatsnew/whatsnew.html>

Subscribe to the *What's New in Cisco Product Documentation* as a Really Simple Syndication (RSS) feed and set content to be delivered directly to your desktop using a reader application. The RSS feeds are a free service and Cisco currently supports RSS version 2.0.

This document is to be used in conjunction with the documents listed in the “[Related Documentation](#)” section.

Cisco and the Cisco logo are trademarks or registered trademarks of Cisco and/or its affiliates in the U.S. and other countries. To view a list of Cisco trademarks, go to this URL: www.cisco.com/go/trademarks. Third-party trademarks mentioned are the property of their respective owners. The use of the word partner does not imply a partnership relationship between Cisco and any other company. (1110R)

Any Internet Protocol (IP) addresses used in this document are not intended to be actual addresses. Any examples, command display output, and figures included in the document are shown for illustrative purposes only. Any use of actual IP addresses in illustrative content is unintentional and coincidental.

Copyright © 2002, Cisco Systems, Inc.
All rights reserved.

