



## Storage Access Networking Cards

The Fibre Channel Multirate 4-Port (FC\_MR-4) card is a 1.0625- or 2.125-Gbps Fibre Channel/fiber connectivity (FICON) card that integrates non-SDH framed protocols into an SDH time-division multiplexing (TDM) platform through virtually concatenated (VCAT) payloads. This chapter provides information about the FC\_MR-4 card. For installation and step-by-step circuit configuration procedures, refer to the Cisco ONS 15454 SDH Procedure Guide.

Chapter topics include:

- [6.1 FC\\_MR-4 Card Overview, page 6-1](#)
- [6.2 FC\\_MR-4 Card Modes, page 6-3](#)
- [6.3 FC\\_MR-4 Card Application, page 6-6](#)
- [6.4 FC\\_MR-4 Card GBICs, page 6-7](#)

### 6.1 FC\_MR-4 Card Overview



**Note**

For specifications, see the [“A.8.1 FC\\_MR-4 Card Specifications”](#) section on page A-48.

The FC\_MR-4 card uses pluggable Gigabit Interface Converters (GBICs) to transport non-SONET/SDH-framed, block-coded protocols over SONET/SDH. The FC\_MR-4 enables four client Fibre Channel (FC) ports to be transported over SONET/SDH, encapsulating the frames using the ITU-T generic framing procedure (GFP) format and mapping them into either T1X1 G.707-based VCAT payloads or standard contiguously concatenated SONET/SDH payloads. The FC\_MR-4 card has the following features:

- Four FICON ports operating at 1 Gbps or 2 Gbps
  - All four ports can be operational at any time due to subrate support
  - Advanced distance extension capability (buffer-to-buffer [B2B] credit spoofing)
- Pluggable GBIC optics
  - Dual rate (1G/2G): MM (550 m) and SM (10 km)
  - Single rate (1G): SX (550 m) and LX (10 km)
- SONET/SDH support
  - Four 1.0625-Gbps FC channels can be mapped into one of the following:

SONET containers as small as STS1-1v (subrate)  
 SDH containers as small as VC4-1v (subrate)  
 SONET/SDH containers as small as STS-18c/VC4-6v (full rate)

- Four 2.125 Gbps FC channels can be mapped into one of the following:

SONET containers as small as STS1-1v (subrate)  
 SDH containers as small as VC4-1v (subrate)  
 SONET/SDH containers as small as STS36c/VC4-12v (full rate)

- Frame encapsulation: ITU-T G.7041 transparent generic framing procedure (GFP-T)
- High-order SONET/SDH VCAT support (STS1-Xv and STS3c-Xv/VC4-Xv)
- Differential delay support for VCAT circuits
- Interoperation with the Cisco MDS 9000 switches

Figure 6-1 shows the FC\_MR-4 faceplate and block diagram.

**Figure 6-1** FC\_MR-4 Faceplate and Block Diagram

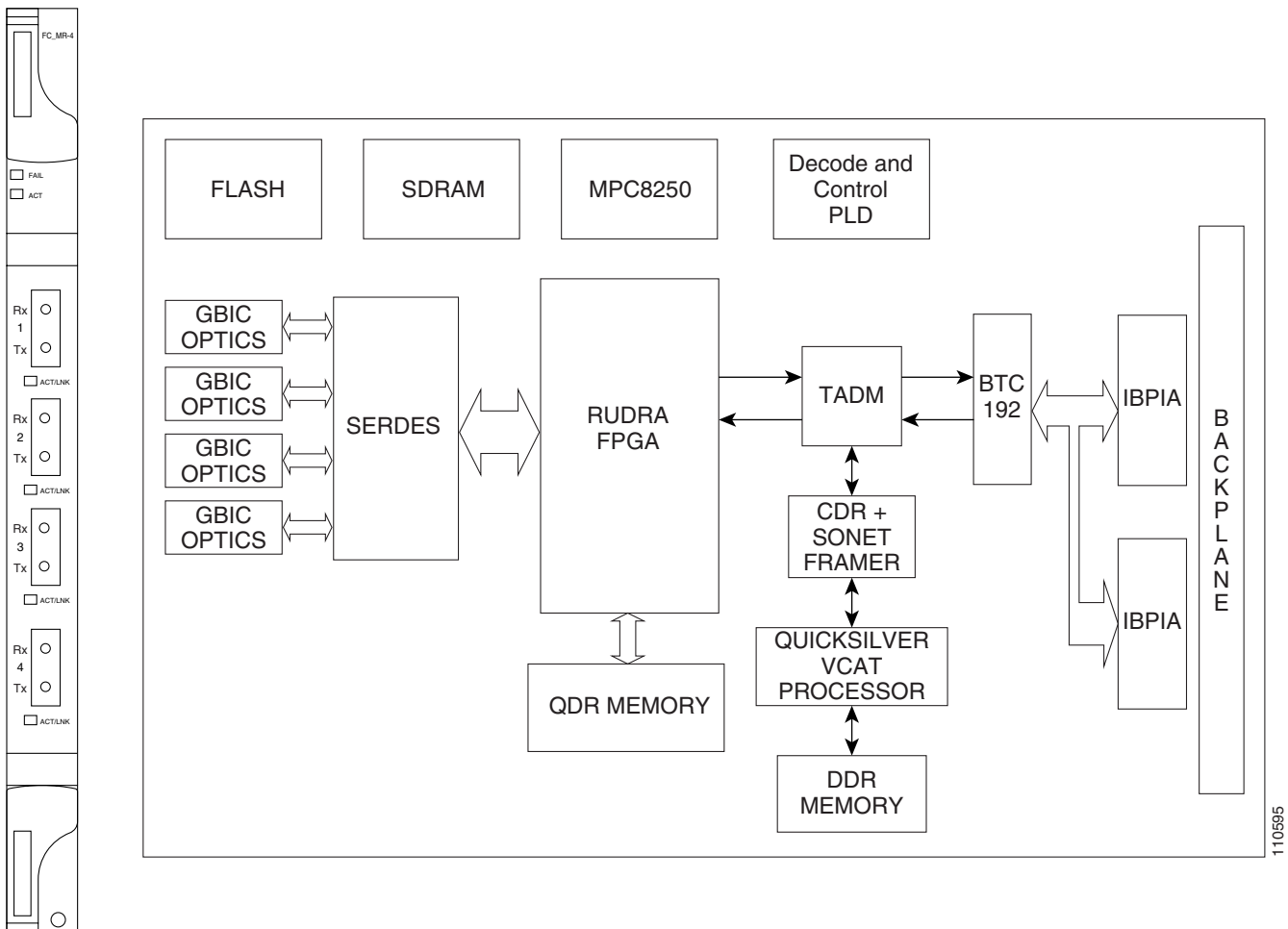

## 6.1.1 FC\_MR-4 Card-Level Indicators

Table 6-1 describes the two card-level LEDs on the FC\_MR-4 card.

**Table 6-1** FC\_MR-4 Card-Level Indicators

Card-Level Indicators	Description
Red FAIL LED	The red FAIL LED indicates that the card's processor is not ready. Replace the card if the red FAIL LED persists.
Green ACT LED	If the ACTV/STBY LED is green, the card is operational and ready to carry traffic.
Amber ACT LED	If the ACTV/STBY LED is amber, the card is rebooting.

## 6.1.2 FC\_MR-4 Port-Level Indicators

Each FC\_MR-4 port has a corresponding ACT/LNK LED. The ACT/LNK LED is solid green if the port is available to carry traffic, is provisioned as in-service, and is in the active mode. The ACT/LNK LED is flashing green if the port is carrying traffic. The ACT/LNK LED is steady amber if the port is not enabled and the link is connected, or if the port is enabled and the link is connected but there is an SONET/SDH transport error. The ACT/LNK LED is not lit if there is no link.

You can find the status of the card ports using the LCD screen on the ONS 15454 SDH fan-tray assembly. Use the LCD to view the status of any port or card slot; the screen displays the number and severity of alarms for a given port or slot. Refer to the *Cisco ONS 15454 SDH Troubleshooting Guide* for a complete description of the alarm messages.

## 6.1.3 FC\_MR-4 Compatibility

The FC\_MR-4 cards can be installed in Slots 1 to 6 and 12 to 17 when used with XC-VXL-2.5G, XC-VXL-10G, and XC-VXC-10G cards. The FC\_MR-4 card can be provisioned as part of any valid ONS 15454 SONET/SDH network topology, such as subnetwork connection protection ring (SNCP) (CCAT circuits only), multiplex section-shared protection ring (MS-SPRing), 1+1 subnetwork connection (SNC), unprotected, and linear network topologies. The FC\_MR-4 card is compatible with Software Release 4.6 and greater.

## 6.2 FC\_MR-4 Card Modes

The FC\_MR-4 card can operate in two modes:

- Line rate mode. This mode is backward compatible with Software R4.6 line rate mode.
- Enhanced mode. This mode supports subrate, distance extension, differential delay, and other enhancements.

The FC\_MR-4 card reboots when changing card modes (a traffic hit results). The FPGA running on the card upgrades to the required image. However, the FPGA image in the card's flash is not modified.

## 6.2.1 Line-Rate Card Mode

The mapping for the line rate card mode is summarized here.

- 1-Gbps Fibre Channel/FICON is mapped into:
  - STS24c, STS48c
  - VC4-8c, VC4-16c
  - STS1-Xv where X is 19 to 24
  - STS3c-Xv where X is 6 to 8
  - VC4-Xv where X is 6 to 8
- 2-Gbps Fibre Channel/FICON is mapped into:
  - STS48c
  - VC4-16c
  - STS1-Xv where X is 37 to 48
  - STS3c-Xv where X is 12 to 16
  - VC4-Xv where X is 12 to 16

## 6.2.2 Enhanced Card Mode

Features available in enhanced card mode are given in this section.

### 6.2.2.1 Mapping

1-Gbps Fibre Channel/FICON is mapped into:

- STS-1, STS-3c, STS-6c, STS-9c, STS-12c, STS-18c, STS-24c, STS-48c
- VC4-1c, VC4-2c, VC4-3c, VC4-4c, VC4-6c, VC4-8c, VC4-16c
- STS-1-Xv where X is 1 to 24
- STS-3c-Xv where X is 1 to 8
- VC4-Xv where X is 1 to 8

2-Gbps Fibre Channel/FICON is mapped into:

- STS-1, STS-3c, STS-6c, STS-9c, STS-12c, STS-18c, STS-24c, STS-36c, STS-48c
- VC4-1c, VC4-2c, VC4-3c, VC4-4c, VC4-6c, VC4-8c, VC4-12c, VC4-16c
- STS-1-Xv where X is 1 to 48
- STS-3c-Xv where X is 1 to 16
- VC4-Xv where X is 1 to 16

### 6.2.2.2 SW-LCAS

VCAT group (VCG) is reconfigurable when the software link capacity adjustment scheme (SW-LCAS) is enabled, as follows:

- Out-of-service (OOS) and out-of-group (OOG) members can be removed from the VCG.

- Members with deleted cross-connects can be removed from VCGs.
- Errored members can be autonomously removed from VCGs.
- Degraded bandwidth VCGs are supported.
- VCG is flexible when SW-LCAS is enabled. (VCG can run traffic as soon as the first cross-connect is provisioned on both sides of the transport.)

### 6.2.2.3 Distance Extension

This following list describes FC\_MR-4 card distance extension capabilities:

- Enabling of a storage access networking (SAN) extension over long distances through B2B credit spoofing:
  - 2300 km for 1G ports (longer distances supported with lesser throughput)
  - 1150 km for 2G ports (longer distances supported with lesser throughput)
- Negotiation mechanism to identify if far-end FC-over-SONET card supports Cisco proprietary B2B mechanism.
- Autodetection of FC switch B2B credits from FC-SW standards-based ELP frames
- Support for manual provisioning of credits based on FC switch credits
- Automatic GFP buffer adjustment based on round trip latency between two SL ports
- Automatic credit recovery during SONET switchovers/failures
- Insulation for FC switches from any SONET switchovers. No FC fabric reconvergences for SONET failures of less than or equal to 60 ms.

### 6.2.2.4 Differential Delay Features

The combination of VCAT, SW-LCAS, and GFP specifies how to process information for data and storage clients. The resulting operations introduce delays. Their impact depends on the type of service being delivered. For example, storage requirements call for very low latency, as opposed to traffic such as e-mail, where latency variations are not critical.

With VCAT, SDH paths are grouped to aggregate bandwidth to form VCGs. Because each VCG member can follow a unique physical route through a network, there are differences in propagation delay, and possibly processing delays between members. The overall VCG propagation delay corresponds to that of the slowest member. The VCAT differential delay is the relative arrival time measurement between members of a VCG. The FC\_MR-4 card is able to handle VCAT differential delay and provides these associated features:

- Supports a maximum of 122 ms of delay difference between the shortest and longest paths.
- Supports diverse fiber routing for VCAT circuit.
- All protection schemes are supported (SNCP [CCAT circuits only], MS-SPRing, protection channel access [PCA]).
- Supports routing of VCAT group members through different nodes in the SDH cloud.
- Differential delay compensation is automatically enabled on VCAT circuits that are diversely (split-fiber) routed, and disabled on VCAT circuits that are common-fiber routed.

**Note**

---

Differential delay support for VCAT circuits is supported by means of a TL1 provisioning parameter (BUFFERS) in the ENT-VCG command.

---

### 6.2.2.5 Interoperability Features

The interoperability features are as follows:

- Maximum frame size setting to prevent accumulation of oversized performance monitoring (PM) parameters for virtual SAN (VSAN) frames
- Ingress filtering disabled for attachment to third-party GFP-over-SONET/SDH equipment
- String (port name) provisioning for each fiber channel and FICON interface on the FC\_MR-4 card to allow the MDS Fabric Manager to create link association between a SAN port on a Cisco MDS 9000 switch and the FC\_MR-4 SAN port.

## 6.2.3 Link Integrity

The link integrity features are as follows:

- The data port is disabled if the upstream data port is not able to send over SONET/SDH transport.
- The data port is disabled if SONET/SDH transport is errored.

## 6.2.4 Link Recovery

Link recovery has the following features:

- Reduces the impact of SONET/SDH disruptions on attached Fibre Channel equipment
- Speeds up the recovery of Inter-Switch Links (ISLs)
- Allows the monitoring of B2B credit depletion due to SONET outage and the full recovery of the credits, thus preventing the slow decay of the bandwidth/throughput

**Note**

---

Distance Extension and Link Recovery cannot be enabled at the same time.

---

## 6.3 FC\_MR-4 Card Application

The FC\_MR-4 card reliably transports carrier-class, private-line Fibre Channel/FICON transport service. Each FC\_MR-4 card can support up to four 1-Gbps circuits or four 2-Gbps circuits. Four 1.0625-Gbps FC channels can be mapped into containers as small as STS-1 (substrate), with a minimum of STS-18c/VC4-6v for full rate. Four 2.125-Gbps FC channels can be mapped into containers as small as STS-1 (substrate), with a minimum of STS-36c/VC4-12v for full rate.

The FC\_MR-4 card incorporates features optimized for carrier-class applications such as:

- Carrier-class Fibre Channel/FICON
- 50 ms of switch time through SONET/SDH protection as specified in Telcordia GR-253-CORE



**Note** Protection switch traffic hit times of less than 60 ms are not guaranteed with differential delay in effect.

- Hitless software upgrades



**Note** Hitless software upgrades are not possible with an activation from 5.0 to 6.0 in enhanced card mode. This is because the FPGA must be upgraded to support differential delay in enhanced mode. Upgrades are still hitless with the line rate mode.

- Remote Fibre Channel/FICON circuit bandwidth upgrades by means of integrated Cisco Transport Controller (CTC)
- Multiple management options through CTC, Cisco Transport Manager (CTM), TL1 (for SONET only), and Simple Network Management Protocol (SNMP)
- Differential delay compensation of up to 122 ms for diversely routed VCAT circuits

The FC\_MR-4 payloads can be transported over the following protected circuit types, in addition to unprotected circuits:

- SNCP (CCAT circuits only)
- MS-SPRing
- PCA

The FC\_MR-4 card supports high-order VCAT. See the [“11.15 Virtual Concatenated Circuits”](#) section on page 11-25 for more information about VCAT circuits.

## 6.4 FC\_MR-4 Card GBICs

The FC\_MR-4 uses pluggable GBICs for client interfaces. [Table 6-2](#) lists the GBICs that are compatible with the FC\_MR-4 card.

**Table 6-2** GBIC Compatibility

Card	Compatible GBIC (Cisco Product ID)	Cisco Top Assembly Number (TAN)
FC_MR-4 (ONS 15454 SONET/SDH)	15454-GBIC-SX	30-0759-01
	15454E-GBIC-SX	800-06780-01
	15454-GBIC-LX/LH	10-1743-01
	15454E-GBIC-LX/LH	30-0703-01
	ONS-GX-2FC-MMI	10-2015-01
	ONS-GX-2FC-SML	10-2016-01

