



Common Control Cards

This chapter describes the Cisco ONS 15454 SDH common control card functions. It includes descriptions, hardware specifications, and block diagrams for each card. For installation and card turn-up procedures, refer to the *Cisco ONS 15454 SDH Procedure Guide*.

Chapter topics include:

- [2.1 Common Control Card Overview, page 2-1](#)
- [2.2 TCC2 Card, page 2-5](#)
- [2.3 TCC2P Card, page 2-9](#)
- [2.4 XC-VXL-10G Card, page 2-13](#)
- [2.5 XC-VXL-2.5G Card, page 2-15](#)
- [2.6 XC-VXC-10G Card, page 2-17](#)
- [2.7 AIC-I Card, page 2-21](#)

2.1 Common Control Card Overview

The card overview section summarizes card functions and compatibility.

Each card is marked with a symbol that corresponds to a slot (or slots) on the ONS 15454 SDH shelf assembly. The cards are then installed into slots that display the same symbols. See the [“1.12.1 Card Slot Requirements”](#) section on page 1-15 for a list of slots and symbols.

2.1.1 Card Summary

[Table 2-1](#) shows the ONS 15454 SDH common control cards and summarizes card functions.

Table 2-1 Common Control Cards for the ONS 15454 SDH

Card	Description	For Additional Information...
TCC2	The Advanced Timing, Communications, and Control (TCC2) card is the main processing center of the ONS 15454 SDH and provides system initialization, provisioning, alarm reporting, maintenance, and diagnostics.	See the “2.2 TCC2 Card” section on page 2-5.
TCC2P	The Advanced Timing, Communications, and Control Plus (TCC2P) card is the main processing center of the ONS 15454 SDH and provides system initialization, provisioning, alarm reporting, maintenance, and diagnostics. This card also has enhanced Ethernet security features.	See the “2.3 TCC2P Card” section on page 2-9.
XC-VXL-10G	The International Cross Connect 10 Gigabit AU3/AU4 High-Capacity Tributary (XC-VXL-10G) card is the central element for switching; it establishes connections and performs time-division switching (TDS). It supports cards with speeds up to 10 Gbps.	See the “2.4 XC-VXL-10G Card” section on page 2-13.
XC-VXL-2.5G	The International Cross Connect 2.5 Gigabit AU3/AU4 High-Capacity Tributary (XC-VXL-2.5G) card is the central element for switching; it establishes connections and performs TDS. It supports cards with speeds up to 2.5 Gbps.	See the “2.5 XC-VXL-2.5G Card” section on page 2-15.
XC-VXC-10G	The 10 Gigabit Cross Connect Virtual Tributary/Virtual Container (XC-VXC-10G) card serves as the switching matrix for the Cisco 15454 SDH multiservice platform. The module operates as a superset of the XC-VXL-10G or XC-VXL-2.5G cross-connect modules. The XC-VXC-10G supports cards with speeds up to 10 Gbps.	See the “2.6 XC-VXC-10G Card” section on page 2-17.
AIC-I	The Alarm Interface Controller–International (AIC-I) card provides customer-defined alarm input/output (I/O), supports user data, and supports local and express orderwire.	See the “2.7 AIC-I Card” section on page 2-21.

2.1.2 Card Compatibility

Table 2-2 lists the Cisco Transport Controller (CTC) software release compatibility for each common-control card. In the tables below, “Yes” means the card is compatible with the listed software version. Table cells with dashes mean cards are not compatible with the listed software versions.

Table 2-2 Common-Control Card Software Release Compatibility

Card	R4.0	R4.1	R4.5	R4.6	R4.7	R5.0	R6.0
TCC2	Yes	Yes	Yes	Yes	Yes	Yes	Yes
TCC2P	Yes	Yes	Yes	Yes	Yes	Yes	Yes
XC10G	Yes	Yes	—	Yes	—	Yes	No
XC-VXL-10G	Yes	Yes	—	Yes	—	Yes	Yes
XC-VXL-2.5G	Yes	Yes	—	Yes	—	Yes	Yes
XC-VXC-10G	—	—	—	—	—	—	Yes
AIC-I	Yes	Yes	Yes	Yes	Yes	Yes	Yes

2.1.3 Cross-Connect Card Compatibility

The following tables list the compatible cross-connect cards for each Cisco ONS 15454 SDH common-control card. The tables are organized according to type of common-control card. In the tables below, “Yes” means the card is compatible with the listed cross-connect card. Table cells with dashes mean cards are not compatible with the listed cross-connect card.

Table 2-3 lists the cross-connect card compatibility for each common-control card.

Table 2-3 Common-Control Card Cross-Connect Compatibility

Card	XC10G Card	XC-VXL-2.5G Card	XC-VXL-10G Card	XC-VXC-10G Card
TCC2	Yes	Yes	Yes	Yes
TCC2P	Yes	Yes	Yes	Yes
XC-VXL-10G	— ¹	— ¹	Yes	— ¹
XC-VXL-2.5G	—	Yes	— ¹	— ¹
XC10G	Yes	—	— ¹	— ¹
XC-VXC-10G	— ¹	— ¹	— ¹	Yes
AIC-I	Yes	Yes	Yes	Yes

1. Cross-connect cards are compatible only during an upgrade (downgrades are not supported).

Table 2-4 lists the cross-connect card compatibility for each electrical card. “Yes” means that the electrical card is compatible with the listed cross-connect card. Table cells with dashes mean cards are not compatible with the listed cross-connect cards. For electrical card software compatibility, see Table 3-2 on page 3-4.

Table 2-4 Electrical Card Cross-Connect Compatibility

Electrical Card	XC10G Card	XC-VXL-2.5G Card	XC-VXL-10G Card	XC-VXC-10G Card
E1-N-14	Yes	Yes	Yes	Yes
E1-42	Yes	Yes	Yes	Yes
E3-12	Yes	Yes	Yes	Yes

Table 2-4 Electrical Card Cross-Connect Compatibility (continued)

Electrical Card	XC10G Card	XC-VXL-2.5G Card	XC-VXL-10G Card	XC-VXC-10G Card
DS3i-N-12	Yes	Yes	Yes	Yes
STM1E-12	—	Yes	Yes	Yes

Table 2-5 lists the cross-connect card compatibility for each optical card. “Yes” means that the optical card is compatible with the listed cross-connect card. Table cells with dashes mean cards are not compatible with the listed cross-connect cards. For optical card software compatibility, see Table 4-2 on page 4-4.

Table 2-5 Optical Card Cross-Connect Compatibility

Optical Card	XC10G Card	XC-VXL-2.5G Card	XC-VXL-10G Card	XC-VXC-10G Card
OC3 IR 4/STM1 SH 1310	Yes	Yes	Yes	Yes
OC3 IR /STM1SH 1310-8	Yes	Yes	Yes	Yes
OC12 IR/STM4 SH 1310	Yes	Yes	Yes	Yes
OC12 LR/STM4 LH 1310	Yes	Yes	Yes	Yes
OC12 LR/STM4 LH 1550	Yes	Yes	Yes	Yes
OC12 IR/STM4 SH 1310-4	Yes	Yes	Yes	Yes
OC48 IR/STM16 SH AS 1310	Yes	Yes	Yes	Yes
OC48 LR/STM16 LH AS 1550	Yes	Yes	Yes	Yes
OC48 ELR/STM16 EH 100 GHz	Yes	Yes	Yes	Yes
OC192 SR/STM64 IO 1310	Yes	—	Yes	Yes
OC192 IR/STM64 SH 1550	Yes	—	Yes	Yes
OC192 LR/STM64 LH 1550	Yes	—	Yes	Yes
OC192 LR/STM64 LH ITU 15xx.xx	Yes	—	Yes	Yes
OC192SR1/STM64IO Short Reach and OC192/STM64 Any Reach ¹	—	—	Yes	Yes
15454_MRC-12	—	Yes	Yes	Yes

1. Designated as STM64-XFP in CTC

Table 2-6 lists the cross-connect card compatibility for each Ethernet card.

Table 2-6 Ethernet Card Cross-Connect Compatibility

Ethernet Cards	XC10G Card	XC-VXL-2.5G Card	XC-VXL-10G Card	XC-VXC-10G Card
E100T-G	Yes	Yes	Yes	Yes
E1000-2-G	Yes	Yes	Yes	Yes
G1000-4	Yes	Yes	Yes	Yes
G1K-4	Yes	Yes	Yes	Yes
ML100T-12	Yes	Yes	Yes	Yes

Table 2-6 Ethernet Card Cross-Connect Compatibility

Ethernet Cards	XC10G Card	XC-VXL-2.5G Card	XC-VXL-10G Card	XC-VXC-10G Card
ML1000-2	Yes	Yes	Yes	Yes
ML100X-8	Yes	Yes	Yes	Yes
CE-100T-8	—	Yes	Yes	Yes

Table 2-6 lists the cross-connect card compatibility for the FC_MR-4 card. “Yes” means that the storage area network (SAN) card is compatible with the listed cross-connect card. Table cells with dashes mean cards are not compatible with the listed cross-connect cards. For software compatibility, see the “6.1.3 FC_MR-4 Compatibility” section on page 6-3.

Table 2-7 SAN Card Cross-Connect Compatibility

SAN Cards	XC10G Card	XC-VXL_2.5G Card	XC-VXL_10G Card	XC-VXC-10G Card
FC_MR-4	—	Yes	Yes	Yes

2.2 TCC2 Card

Note

For TCC2 card specifications, see the “A.4.1 TCC2 Card Specifications” section on page A-10.

The TCC2 card, which requires Software Release 4.0 or later, performs system initialization, provisioning, alarm reporting, maintenance, diagnostics, IP address detection/resolution, SDH section overhead (SOH) data communications channel/generic communication channel (DCC/GCC) termination, and system fault detection for the ONS 15454 SDH. The TCC2 card also ensures that the system maintains Stratum 3 timing requirements. It monitors the supply voltage of the system.

Note

The LAN interfaces of the TCC2 card meet the standard Ethernet specifications by supporting a cable length of 100 m (328 ft.) at temperatures from 0 to 65 degrees Celsius (32 to 149 degrees Fahrenheit). The interfaces can operate with a cable length of 10 m (32.8 ft) maximum at temperatures from –40 to 0 degrees Celsius (–40 to 32 degrees Fahrenheit).

Figure 2-1 shows the TCC2 card faceplate and block diagram.

Figure 2-1 TCC2 Faceplate and Block Diagram

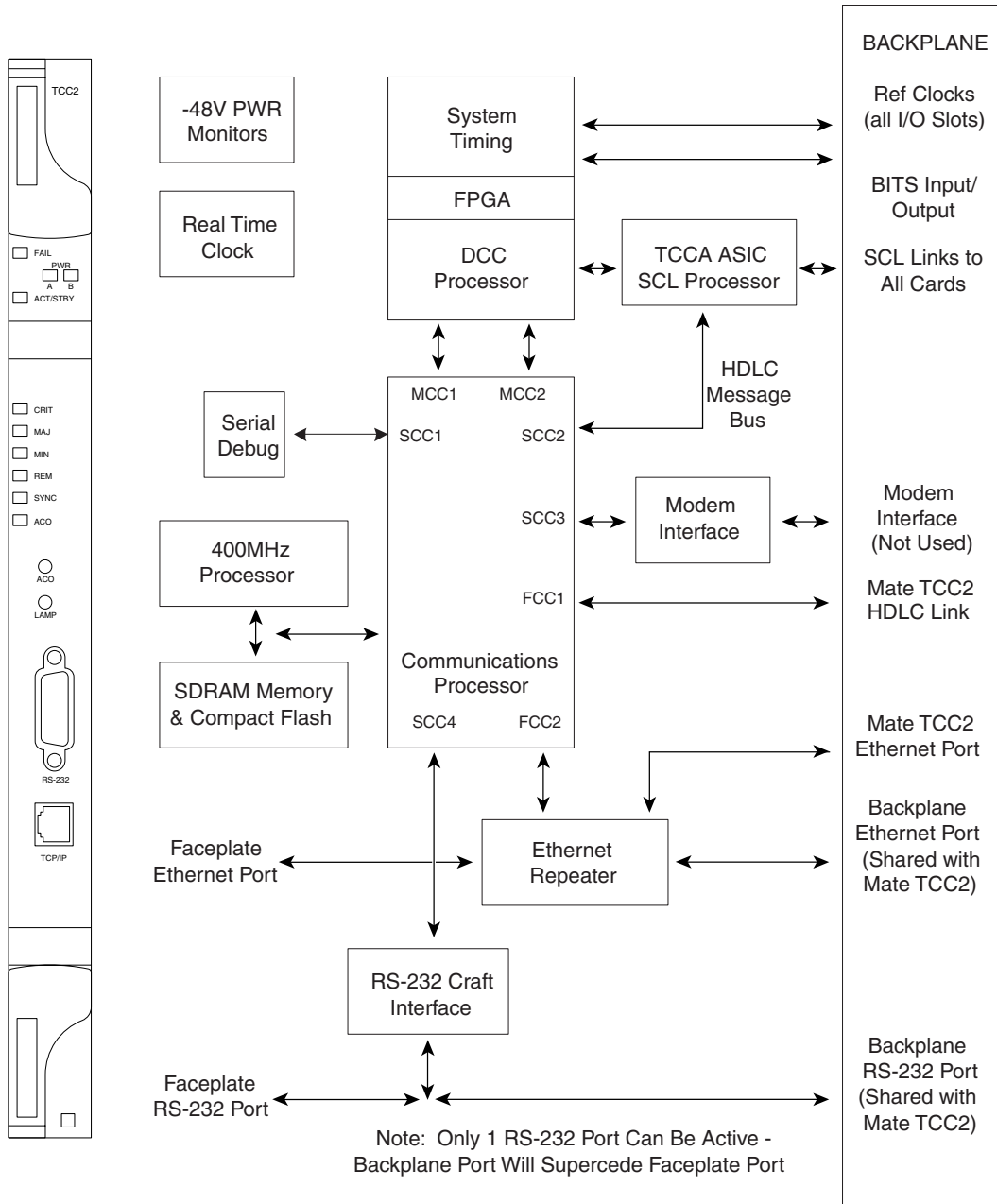

2.2.1 TCC2 Card Functionality

The TCC2 card supports multichannel, high-level data link control (HDLC) processing for the DCC/GCC. Up to 84 DCCs can be routed over the TCC2 card and up to 84 section DCCs can be terminated at the TCC2 card (subject to the available optical digital communication channels). The TCC2 card selects and processes 84 DCCs to facilitate remote system management interfaces.

The TCC2 card also originates and terminates a cell bus carried over the module. The cell bus supports links between any two cards in the node, which is essential for peer-to-peer communication. Peer-to-peer communication accelerates protection switching for redundant cards.

The node database, IP address, and system software are stored in TCC2 card nonvolatile memory, which allows quick recovery in the event of a power or card failure.

The TCC2 card performs all system-timing functions for each ONS 15454 SDH. It monitors the recovered clocks from each traffic card and two building integrated timing supply (BITS) ports (E1, 2.048 MHz) for frequency accuracy. The TCC2 card selects a recovered clock, a BITS, or an internal Stratum 3 reference as the system-timing reference. You can provision any of the clock inputs as primary or secondary timing sources. A slow-reference tracking loop allows the TCC2 card to synchronize with the recovered clock, which provides holdover if the reference is lost.

The TCC2 card monitors both supply voltage inputs on the shelf. An alarm is generated if one of the supply voltage inputs has a voltage outside of the specified range.

Install TCC2 cards in Slots 7 and 11 for redundancy. If the active TCC2 card fails, traffic switches to the protect TCC2 card. All TCC2 card protection switches conform to protection switching standards when the bit error rate (BER) counts are not in excess of $1 * 10 \text{ exp} - 3$ and completion time is less than 50 ms.

The TCC2 card has two built-in interface ports for accessing the system: an RJ-45 10BaseT LAN interface and an EIA/TIA-232 interface for local craft access. It also has a 10BaseT LAN port for user interfaces through the backplane to the port accessible on the MIC-C/T/P Front Mount Electrical Connection (FMEC).

**Note**

When using the LAN RJ-45 craft interface or back panel wirewrap LAN connection, the connection must be 10BASE T, half duplex. Full duplex and autonegotiate settings should not be used because they might result in a loss of visibility to the node.

**Note**

Cisco does not support operation of the ONS 15454 SDH with only one TCC2 card. For full functionality and to safeguard your system, always operate each ONS 15454 SDH with two TCC2 cards.

**Note**

CTC software does not monitor for the absence of FMECs until the TCC2 card(s) have reached the Active/Standby state. During transitional states such as power-up or TCC2 card reset, CTC ignores the FMEC inventory displayed in node view.

**Note**

When a second TCC2 card is inserted into a node, it synchronizes its software, its backup software, and its database with the active TCC2 card. If the software version of the new TCC2 card does not match the version on the active TCC2 card, the newly inserted TCC2 card copies from the active TCC2 card, taking about 15 to 20 minutes to complete. If the backup software version on the new TCC2 card does not match the version on the active TCC2 card, the newly inserted TCC2 card copies the backup software from the active TCC2 card again, taking about 15 to 20 minutes. Copying the database from the active TCC2 card takes about 3 minutes. Depending on the software version and backup version the new TCC2 card started with, the entire process can take between 3 and 40 minutes.

2.2.2 TCC2 Card-Level Indicators

Table 2-8 describes the two card-level LEDs on the TCC2 card faceplate.

Table 2-8 TCC2 Card-Level Indicators

Card-Level LEDs	Definition
Red FAIL LED	The FAIL LED flashes during the boot and write process. Replace the card if the FAIL LED persists.
ACT/STBY LED Green (Active) Amber (Standby)	The ACT/STBY (Active/Standby) LED indicates the TCC2 card is active (green) or in standby (amber) mode. The ACT/STBY LED also provides the timing reference and shelf control. When the TCC2 card is writing to the active or standby TCC2 card, its active or standby LED blinks. To avoid memory corruption, do not remove the TCC2 card when the active or standby LED is blinking.

2.2.3 Network-Level Indicators

Table 2-9 describes the six network-level LEDs on the TCC2 card faceplate.

Table 2-9 TCC2 Network-Level Indicators

System-Level LEDs	Definition
Red CRIT LED	Indicates Critical alarms in the network at the local terminal.
Red MAJ LED	Indicates Major alarms in the network at the local terminal.
Amber MIN LED	Indicates Minor alarms in the network at the local terminal.
Red REM LED	Provides first-level alarm isolation. The remote (REM) LED turns red when an alarm is present in one or several of the remote terminals.
Green SYNC LED	Indicates that node timing is synchronized to an external reference.
Green ACO LED	After pressing the alarm cutoff (ACO) button, the green ACO LED illuminates. The ACO button opens the audible closure on the backplane. ACO state is stopped if a new alarm occurs. After the originating alarm is cleared, the ACO LED and audible alarm control are reset.

2.2.4 Power-Level Indicators

Table 2-10 describes the two power-level LEDs on the TCC2 faceplate.

Table 2-10 TCC2 Power-Level Indicators

Power-Level LEDs	Definition
Green/Red PWR A LED	The PWR A LED is green when the voltage on supply input A is between the extremely low battery voltage (ELWBATVG) and extremely high battery voltage (EHIBATVG) thresholds. The LED is red when the voltage on supply input A is above extremely high battery voltage or below extremely low battery voltage thresholds.
Green/Red PWR B LED	The PWR B LED is green when the voltage on supply input B is between the extremely low battery voltage (ELWBATVG) and extremely high battery voltage (EHIBATVG) thresholds. The LED is red when the voltage on supply input B is above extremely high battery voltage or below extremely low battery voltage thresholds.

2.3 TCC2P Card



Note

For TCC2P card specifications, see the [“A.4.2 TCC2P Card Specifications”](#) section on page A-10.

The TCC2P card, which requires Software R4.0 or later, is an enhanced version of the TCC2 card. The primary enhancements are Ethernet security features in R5.0 and 64kHz+8kHz clocking in R6.0.

The TCC2P card performs system initialization, provisioning, alarm reporting, maintenance, diagnostics, IP address detection/resolution, SDH regeneration section overhead (RSOH) and multiplex section overhead (MSOH) DCC/GCC termination, and system fault detection for the ONS 15454. The TCC2P also ensures that the system maintains Stratum 3 (ITU-T G.812) timing requirements. It monitors the supply voltage of the system.



Note

The LAN interface of the TCC2P card meets the standard Ethernet specifications by supporting a cable length of 328 ft (100 m) at temperatures from 32 to 149 degrees Fahrenheit (0 to 65 degrees Celsius). The interfaces can operate with a cable length of 32.8 ft (10 m) maximum at temperatures from -40 to 32 degrees Fahrenheit (-40 to 0 degrees Celsius).

Figure 2-2 shows the faceplate and block diagram for the TCC2P card.

Figure 2-2 TCC2P Faceplate and Block Diagram

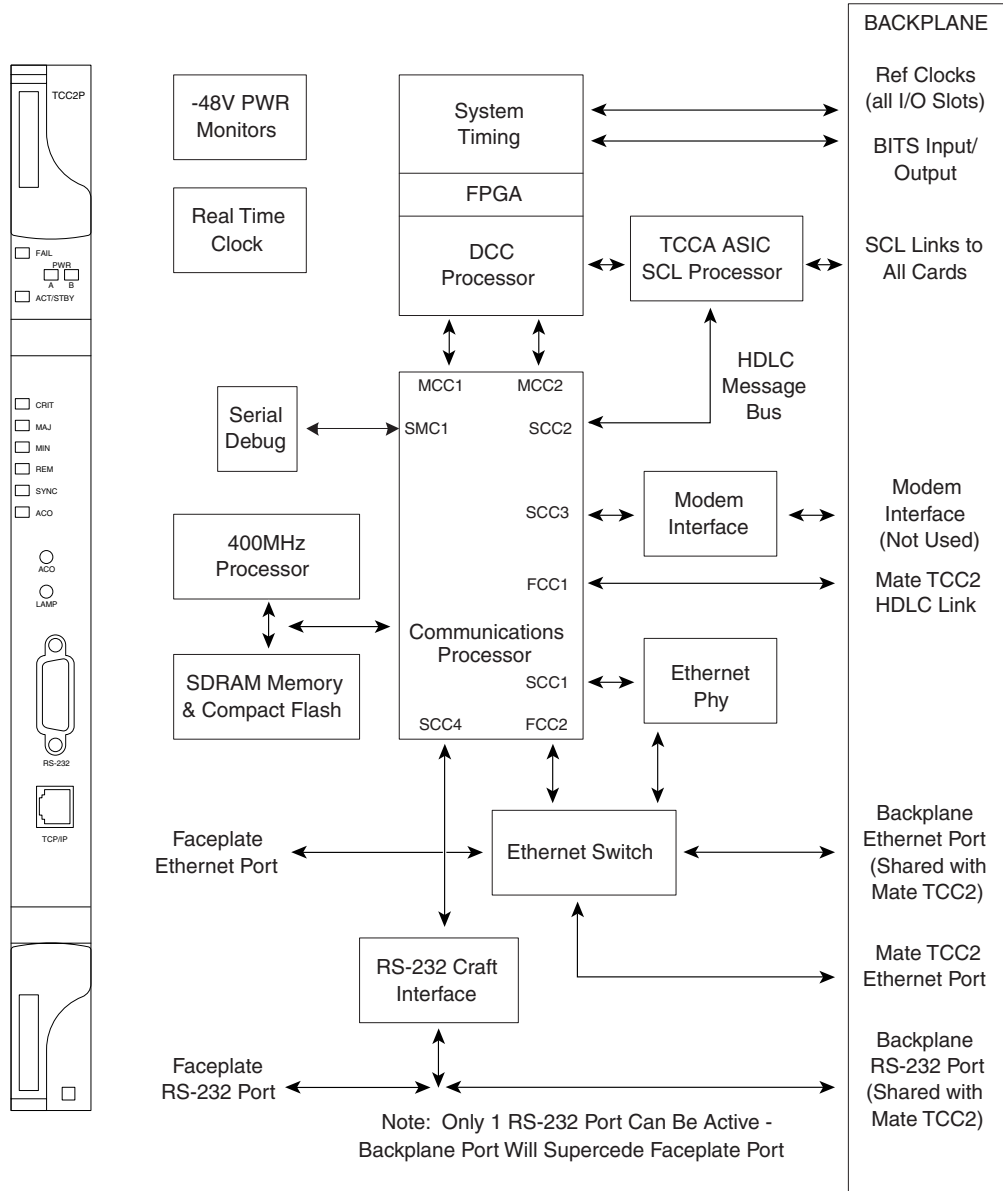

2.3.1 TCC2P Functionality

The TCC2P card supports multichannel, HDLC processing for the DCC. Up to 84 DCCs can be routed over the TCC2P card and up to 84 section DCCs can be terminated at the TCC2P card (subject to the available optical digital communication channels). The TCC2P selects and processes 84 DCCs to facilitate remote system management interfaces.

The TCC2P also originates and terminates a cell bus carried over the module. The cell bus supports links between any two cards in the node, which is essential for peer-to-peer communication. Peer-to-peer communication accelerates protection switching for redundant cards.

The node database, IP address, and system software are stored in TCC2P nonvolatile memory, which allows quick recovery in the event of a power or card failure.

The TCC2P card performs all system-timing functions for each ONS 15454. It monitors the recovered clocks from each traffic card and two BITS ports for frequency accuracy. The TCC2P card selects a recovered clock, a BITS, or an internal Stratum 3 reference as the system-timing reference. You can provision any of the clock inputs as primary or secondary timing sources. A slow-reference tracking loop allows the TCC2P to synchronize with the recovered clock, which provides holdover if the reference is lost.

For Software Release 6.0 and later, the TCC2P card supports a 64 kHz + 8 kHz composite clock BITS IN as well as a BITS OUT clock of 6.312 MHz. The BITS on the system is configurable as E1, 2.048 MHz, or 64 kHz, with E1 being the default. The BITS OUT clock runs at a rate determined by BITS IN, as shown in [Table 2-11](#).

Table 2-11 BITS Clocks

BITS IN	BITS OUT
E1	E1 (default)
2.048 MHz (square wave clock)	2.048 MHz (square wave clock)
64 kHz	6.312 MHz

A BITS output interface configured as 6.312 MHz complies with ITU-T G.703, Appendix II, Table II.4, with a monitor level of -40 dBm +/- 4 dBm.

The TCC2P monitors both supply voltage inputs on the shelf. An alarm is generated if one of the supply voltage inputs has a voltage that is out of the specified range.

Install TCC2P cards in Slots 7 and 11 for redundancy. If the active TCC2P fails, traffic switches to the protect TCC2P. All TCC2P protection switches conform to protection switching standards when the BER counts are not in excess of $1 * 10 \exp - 3$ and completion time is less than 50 ms.

The TCC2P card has two built-in RJ-45 Ethernet interface ports for accessing the system: one on the front faceplate for on-site craft access and a second by means of the backplane to the port that is accessible on the MIC-C/T/P FMEC, for user interfaces. The FMEC Ethernet interface is for permanent LAN access and all remote access via TCP/IP as well as for Operations Support System (OSS) access. The Ethernet interfaces have different IP addresses that are in different subnets.

An EIA/TIA-232 serial port on the faceplate allows for a craft interface in TL1 mode.



Note

When using the LAN RJ-45 craft interface or back panel wirewrap LAN connection, the connection must be 10BASE T, half duplex. Full duplex and autonegotiate settings should not be used because they might result in a loss of visibility to the node.



Note

Cisco does not support operation of the ONS 15454 SDH with only one TCC2P card. For full functionality and to safeguard your system, always operate with two TCC2P cards.

**Note**

When a second TCC2P card is inserted into a node, it synchronizes its software, its backup software, and its database with the active TCC2P. If the software version of the new TCC2P does not match the version on the active TCC2P, the newly inserted TCC2P copies from the active TCC2P, taking about 15 to 20 minutes to complete. If the backup software version on the new TCC2P does not match the version on the active TCC2P, the newly inserted TCC2P copies the backup software from the active TCC2P again, taking about 15 to 20 minutes. Copying the database from the active TCC2P takes about 3 minutes. Depending on the software version and backup version the new TCC2P started with, the entire process can take between 3 and 40 minutes.

2.3.2 TCC2P Card-Level Indicators

The TCC2P faceplate has ten LEDs. [Table 2-12](#) describes the two card-level LEDs on the TCC2P faceplate.

Table 2-12 TCC2P Card-Level Indicators

Card-Level LEDs	Definition
Red FAIL LED	This LED is on during reset. The FAIL LED flashes during the boot and write process. Replace the card if the FAIL LED persists.
ACT/STBY LED Green (Active) Amber (Standby)	Indicates the TCC2P is active (green) or in standby (amber) mode. The ACT/STBY LED also provides the timing reference and shelf control. When the active TCC2P is writing to its database or to the standby TCC2P database, the card LEDs blink. To avoid memory corruption, do not remove the TCC2P when the active or standby LED is blinking.

2.3.3 Network-Level Indicators

[Table 2-13](#) describes the six network-level LEDs on the TCC2P faceplate.

Table 2-13 TCC2P Network-Level Indicators

System-Level LEDs	Definition
Red CRIT LED	Indicates Critical alarms in the network at the local terminal.
Red MAJ LED	Indicates Major alarms in the network at the local terminal.
Amber MIN LED	Indicates Minor alarms in the network at the local terminal.
Red REM LED	Provides first-level alarm isolation. The remote (REM) LED turns red when an alarm is present in one or more of the remote terminals.
Green SYNC LED	Indicates that node timing is synchronized to an external reference.
Green ACO LED	After pressing the ACO button, the ACO LED turns green. The ACO button opens the audible alarm closure on the backplane. ACO is stopped if a new alarm occurs. After the originating alarm is cleared, the ACO LED and audible alarm control are reset.

2.3.4 Power-Level Indicators

Table 2-14 describes the two power-level LEDs on the TCC2P faceplate.

Table 2-14 TCC2P Power-Level Indicators

Power-Level LEDs	Definition
Green/Red PWR A LED	The PWR A LED is green when the voltage on supply input A is between the extremely low battery voltage (ELWBATVG) and extremely high battery voltage (EHIBATVG) thresholds. The LED is red when the voltage on supply input A is above extremely high battery voltage or below extremely low battery voltage thresholds.
Green/Red PWR B LED	The PWR B LED is green when the voltage on supply input B is between the extremely low battery voltage (ELWBATVG) and extremely high battery voltage (EHIBATVG) thresholds. The LED is red when the voltage on supply input B is above extremely high battery voltage or below extremely low battery voltage thresholds.

2.4 XC-VXL-10G Card



Note

For XC-VXL-10G card specifications, see the [“A.4.3 XC-VXL-10G Card Specifications”](#) section on page A-11.

The XC-VXL-10G card cross connects E-1, E-3, DS-3, STM-1, STM-4, STM-16, and STM-64 signal rates. The XC-VXL-10G provides a maximum of 384 x 384 VC-4 nonblocking cross-connections, 384 x 384 VC-3 nonblocking cross-connections, or 2016 x 2016 VC-12 nonblocking cross-connections. It is designed for 10-Gbps solutions.

Figure 2-3 shows the XC-VXL-10G faceplate and block diagram.

Figure 2-3 XC-VXL-10G Faceplate and Block Diagram

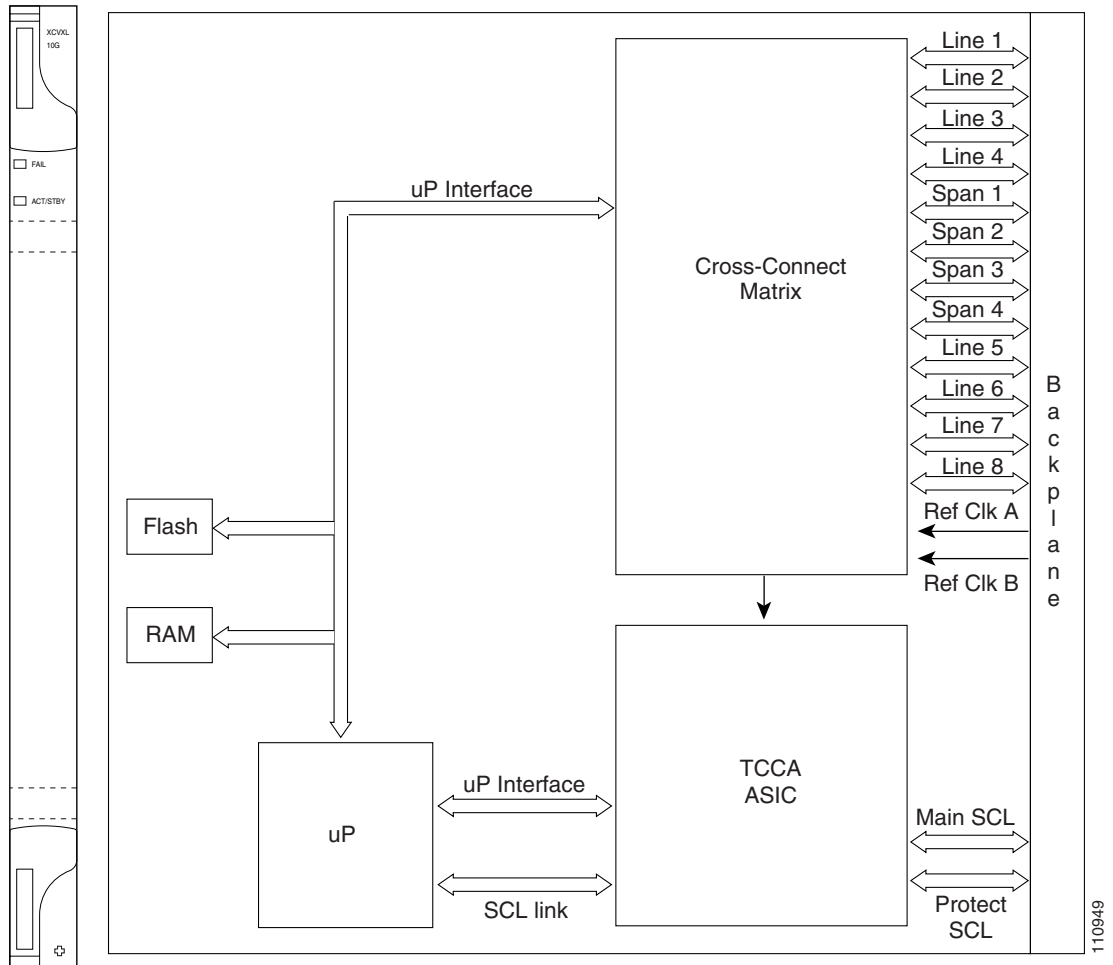
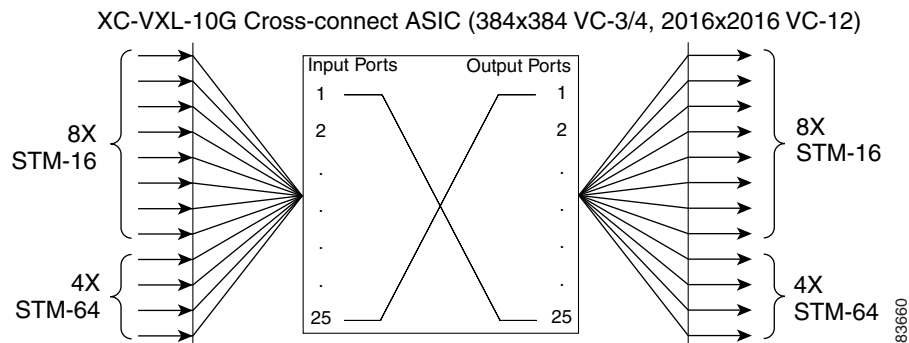

Figure 2-4 shows the XC-VXL-10G cross-connect matrix.

Figure 2-4 XC-VXL-10G Cross-Connect Matrix



2.4.1 XC-VXL-10G Functionality

The XC-VXL-10G card manages up to 192 bidirectional STM-1 cross-connects, 192 bidirectional E-3 or DS-3 cross-connects, or 1008 bidirectional E-1 cross-connects. The TCC2/TCC2P card assigns bandwidth to each slot on a per-STM-1 basis. The XC-VXL-10G card works with the TCC2/TCC2P card to maintain connections and set up cross-connects within the node. You can establish cross-connect and provisioning information through CTC.

Note

Cisco does not support operating the ONS 15454 SDH with only one XC-VXL-10G card. Always operate in a redundant configuration. Install the XC-VXL-10G cards in Slots 8 and 10.

2.4.2 XC-VXL-10G Card-Level Indicators

Table 2-15 describes the two card-level LEDs on the XC-VXL-10G card faceplate.

Table 2-15 XC-VXL-10G Card-Level Indicators

Card-Level LEDs	Definition
Red FAIL LED	Indicates that the card's processor is not ready. The FAIL LED is on during reset and flashes during the boot process. Replace the card if the red FAIL LED persists.
ACT/STBY LED Green (Active) Amber (Standby)	Indicates whether the XC-VXL-10G card is active and carrying traffic (green) or in standby mode to the active XC-VXL-10G card (amber).

2.5 XC-VXL-2.5G Card

Note

For XC-VXL-2.5G card specifications, see the [“A.4.4 XC-VXL-2.5G Card Specifications”](#) section on [page A-12](#).

The XC-VXL-2.5G card cross-connects E-1, E-3, DS-3, STM-1, STM-4, STM-16, and STM-64 signal rates. The XC-VXL-2.5G card provides a maximum of 192 x 192 VC-4 nonblocking cross-connections, 384 x 384 VC-3 nonblocking cross-connections, or 2016 x 2016 VC-12 nonblocking cross-connections. The card is designed for 2.5-Gbps solutions.

Figure 2-5 shows the XC-VXL-2.5G card faceplate and block diagram.

Figure 2-5 XC-VXL-2.5G Faceplate and Block Diagram

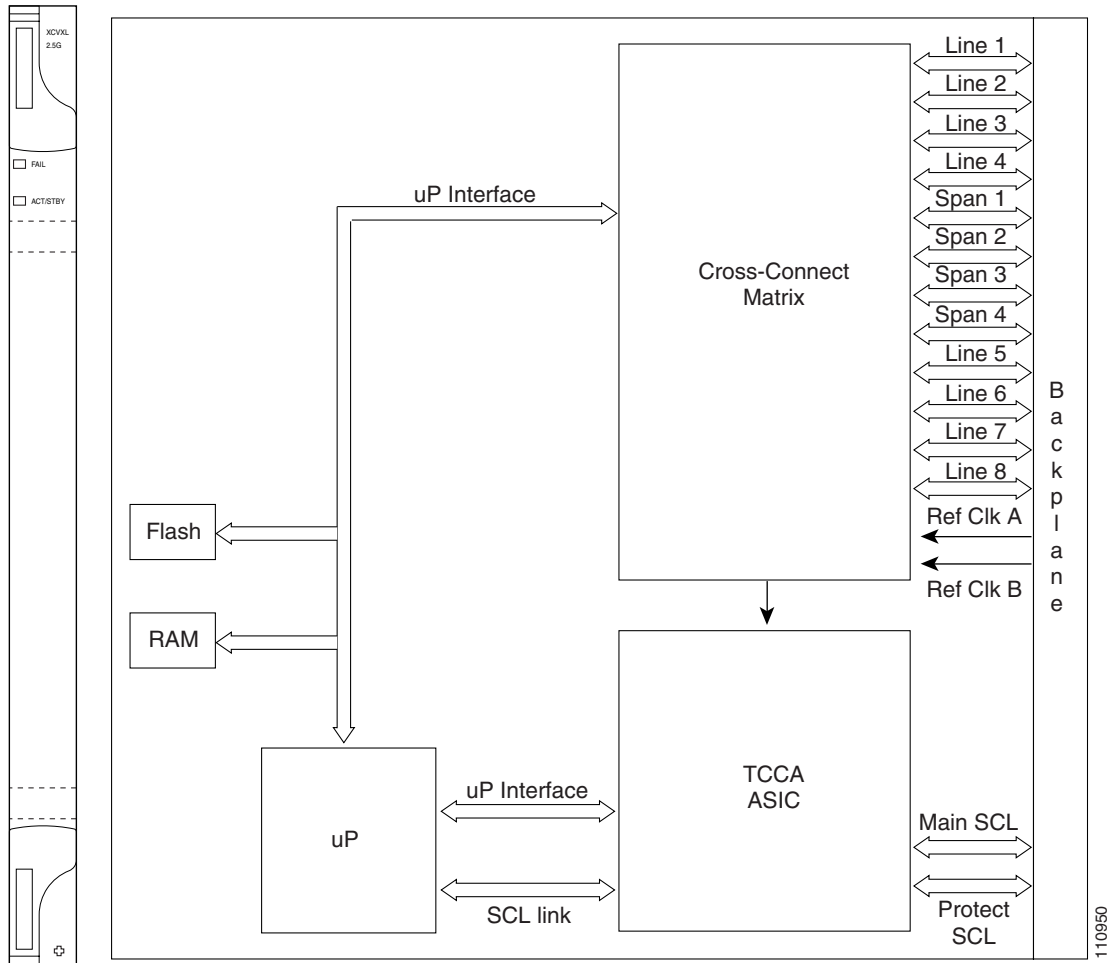
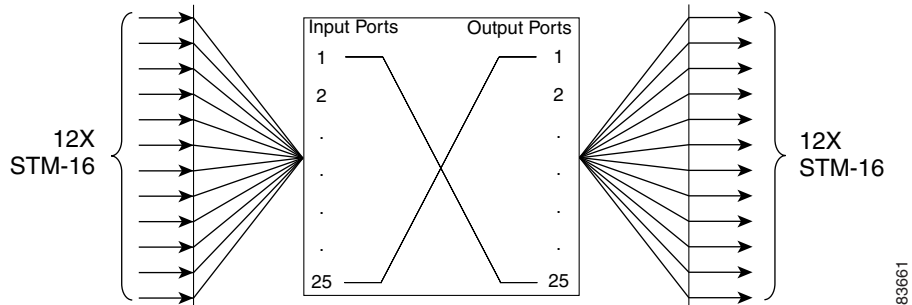

Figure 2-6 shows the XC-VXL-2.5G cross-connect matrix.

Figure 2-6 XC-VXL-2.5G Cross-Connect Matrix

XC-VXL-2.5G Cross-connect ASIC (192x192 VC-4, 384x384 VC-3, 2016x2016 VC-12)



2.5.1 XC-VXL-2.5G Card Functionality

The XC-VXL-2.5G card manages up to 192 bidirectional STM-1 cross-connects, 192 bidirectional E-3 or DS-3 cross-connects, or 1008 bidirectional E-1 cross-connects. The TCC2/TCC2P card assigns bandwidth to each slot on a per-STM-1 basis. The XC-VXL-2.5G card works with the TCC2/TCC2P card to maintain connections and set up cross-connects within the node. You can establish cross-connect and provisioning information through CTC.

Note

Cisco does not support operating the ONS 15454 SDH with only one XC-VXL-2.5G card. Always operate in a redundant configuration. Install the XC-VXL-2.5G cards in Slots 8 and 10.

2.5.2 XC-VXL-2.5G Card-Level Indicators

Table 2-16 describes the two card-level LEDs on the XC-VXL-2.5G faceplate.

Table 2-16 XC-VXL-2.5G Card-Level Indicators

Card-Level LEDs	Definition
Red FAIL LED	The red FAIL LED indicates that the card's processor is not ready. The FAIL LED is on during reset and flashes during the boot process. Replace the card if the red FAIL LED persists.
ACT/STBY LED Green (Active) Amber (Standby)	The ACT/STBY (Active/Standby) LED indicates whether the XC-VXL-2.5G is active and carrying traffic (green) or in standby mode to the active XC-VXL-2.5G card (amber).

2.6 XC-VXC-10G Card

Note

For XC-VXC-10G card specifications, see the [“A.4.5 XC-XVC-10G Card Specifications”](#) section on [page A-12](#).

The XC-VXC-10G card establishes connections at the VC-4, VC-3, VC-12, and VC-11 levels. The XC-VXC-10G cards provides STM-64 capacity to Slots 5, 6, 12, and 13, and STM-16 capacity to Slots 1 to 4 and 14 to 17. Any VC-4 on any port can be connected to any other port, meaning that the VC-4 cross-connections are nonblocking. XC-VXC-10G supports LO circuits on SNCP with non intrusive monitorin

The XC-VXC-10G card can be configured to support either VC-12 or VC-11 grooming, or mixed (VC-12 and VC-11) grooming.

[Figure 2-7](#) shows the XC-VXC-10G faceplate and block diagram.

Figure 2-7 XC-VXC-10G Faceplate and Block Diagram

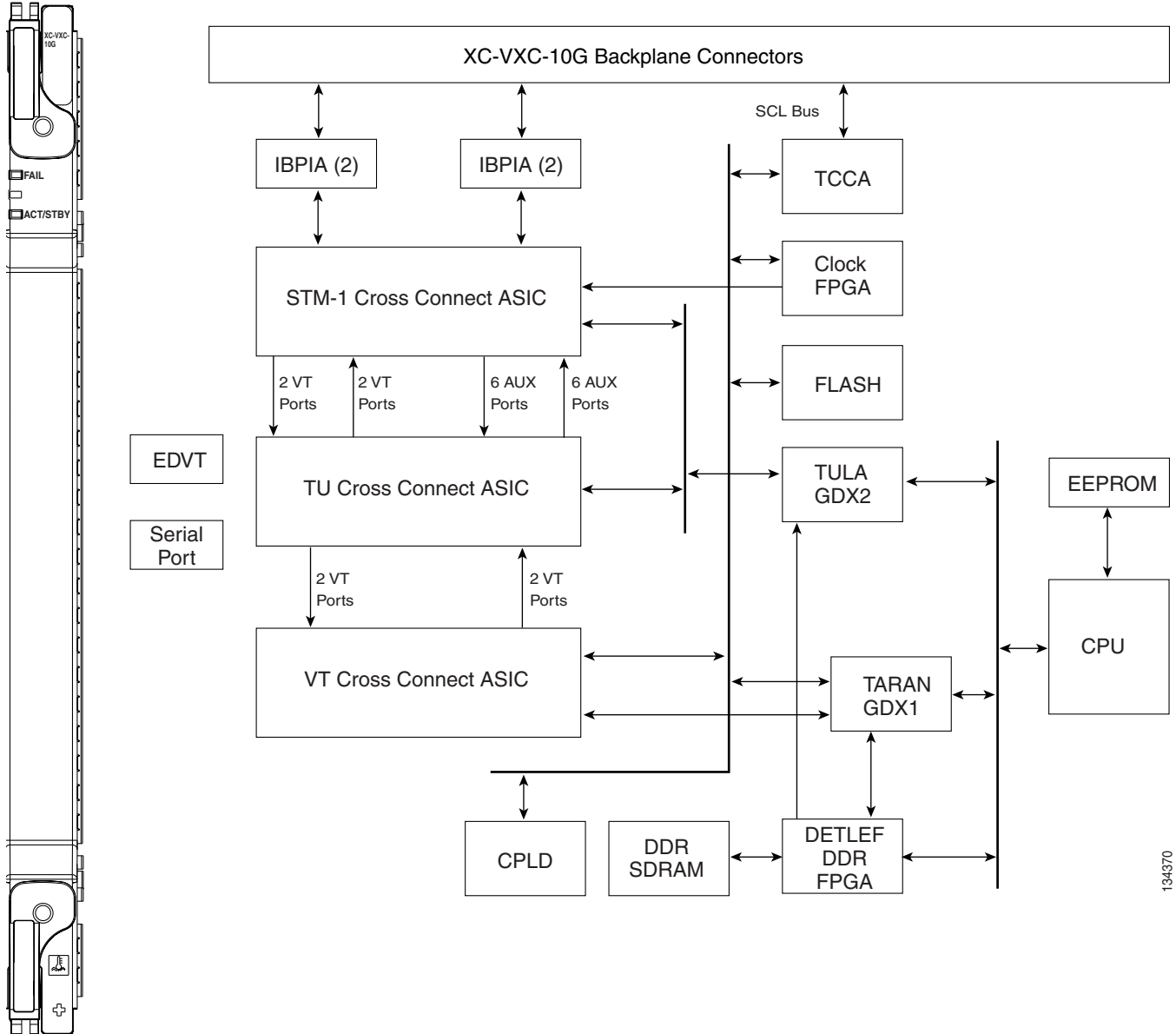

2.6.1 XC-VXC-10G Functionality

The XC-VXC-10G card manages up to 192 bidirectional VC-4 cross-connects, 192 VC-3 bidirectional cross-connects, 1008 VC-12 bidirectional cross-connects, or 1344 VC-11 bidirectional cross-connects. The TCC2/TCC2P card assigns bandwidth to each slot on a per-STM-1 basis.

The XC-VXC-10G card provides the following:

- 384 VC-4 bidirectional ports
- 192 VC-4 bidirectional cross-connects
- 384 VC-3 bidirectional ports

- 192 VC-3 bidirectional cross-connects
- 2016 VC-12 ports by means of 96 logical VC-3 ports
- 1008 VC-12 bidirectional cross-connects
- 2688 VC-11 ports by means of 96 logical VC-3 ports
- 1344 VC-11 bidirectional cross-connects
- Nonblocking operation at the VC-11 level
- VC-11, VC-12, VC-4/-4c/-8c/-16c/-64c cross-connects
- Grooming modes supported:
 - Full VC-12 grooming
 - Full VC-11 grooming
 - Mixed grooming (50%/50%): 1008 x 1008 VC-12/1344 x 1344 VC-11

**Caution**

Do not operate the ONS 15454 with only one XC-VXC-10G card. Two cross-connect cards must always be installed.

The XC-VXC-10G supports errorless side switches (switching from one XC-VXC-10G on one side of the shelf to the other XC-VXC-10G on the other side of the shelf) at the VC-4 circuit level when the switch is initiated through software and the shelf is equipped with TCC2/TCC2P cards.

**Note**

Only the 15454_MRC-12, OC192SR1/STM64IO Short Reach, and OC192/STM64 Any Reach cards (the latter two cards are designated in CTC as STM64-XFP) support errorless side switches.

**Note**

Errorless side switch for the XC-VXC-10G card is not supported at the lower circuit levels (VC-3 and VC-11/VC-12).

Figure 2-8 shows the XC-VXC-10G cross-connect matrix.

Figure 2-8 XC-VXC-10G Cross-Connect Matrix

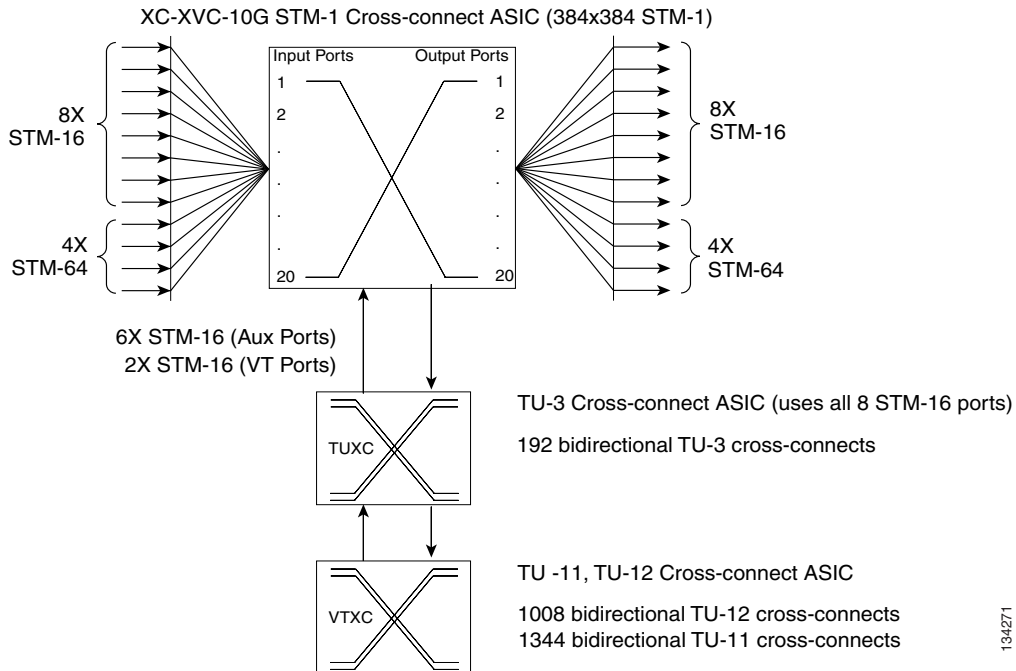

2.6.2 XC-VXC-10G Card-Level Indicators

Table 2-17 describes the two card-level LEDs on the XC-VXC-10G faceplates.

Table 2-17 XC-VXC-10G Card-Level Indicators

Card-Level Indicators	Definition
Red FAIL LED	Indicates that the cards processor is not ready. This LED illuminates during reset. The FAIL LED flashes during the boot process. Replace the card if the red FAIL LED persists.
ACT/STBY LED Green (Active) Amber (Standby)	Indicates whether the XC-VXC-10G is active and carrying traffic (green), or in standby mode to the active XC-VXC-10G card (amber).

2.6.3 XC-VXC-10G Compatibility

The XC-VXC-10G card supports the same features as the XC-VXL-10G and XC-VXL-2.5G cards. The XC-VXC-10G card supports STM-64 operation.

If you are using Ethernet cards, the E1000-2-G or the E100T-G must be used when the XC-VXC-10G cross-connect card is in use. When upgrading from an XC-VXL-10G card to an XC-VXC-10G card, refer to the “Upgrade Cards and Spans” chapter in the *Cisco ONS 15454 SDH Procedure Guide* for more information. See also the “2.1.2 Card Compatibility” section on page 2-2.

2.7 AIC-I Card

 **Note**

For AIC-I card specifications, see the “A.4.6 AIC-I Specifications” section on page A-12.

The optional AIC-I card provides customer-defined alarm inputs and outputs, user data channels (UDCs), and supports local and express orderwire. It provides 16 customer-defined input contacts and 4 customer-defined input/output contacts. It requires the MIC-A/P for connection to the alarm contacts.

Figure 2-9 shows the AIC-I card faceplate and a block diagram of the card.

Figure 2-9 AIC-I Faceplate and Block Diagram

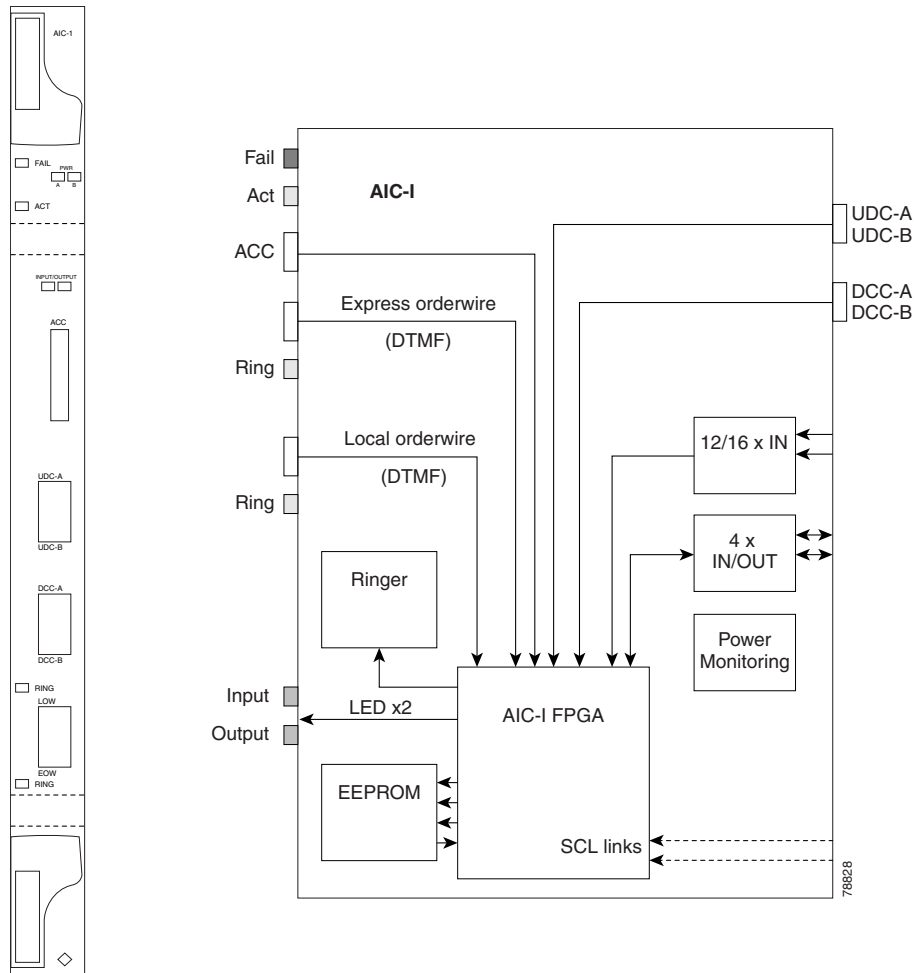

2.7.1 AIC-I Card-Level Indicators

Table 2-18 describes the eight card-level LEDs on the AIC-I card.

Table 2-18 AIC-I Card-Level Indicators

Card-Level LEDs	Description
Red FAIL LED	Indicates that the card's processor is not ready. The FAIL LED is on during reset and flashes during the boot process. Replace the card if the red FAIL LED persists.
Green ACT LED	Indicates that the AIC-I card is provisioned for operation.
Green/Red PWR A LED	When green, indicates that a supply voltage within the specified range has been sensed on supply input A. It is red when the input voltage on supply input A is out of range.
Green/Red PWR B LED	When green, indicates that a supply voltage within the specified range has been sensed on supply input B. It is red when the input voltage on supply input B is out of range.
Amber INPUT LED	When amber, indicates that there is an alarm condition on at least one of the alarm inputs.
Amber OUTPUT LED	When amber, indicates that there is an alarm condition on at least one of the alarm outputs.
Green RING LED	The green RING LED on the local orderwire (LOW) side is flashing when a call is received on the LOW.
Green RING LED	The green RING LED on the express orderwire (EOW) side is flashing when a call is received on the EOW.

2.7.2 External Alarms and Controls

The optional AIC-I card provides input/output alarm contact closures. You can define up to 16 external alarm inputs and four external alarm inputs/outputs (user configurable). The physical connections are made using the MIC-A/P. The alarms are defined using CTC. For instructions, refer to the "Manage Alarms" chapter in the *Cisco ONS 15454 SDH Procedure Guide*.

LEDs on the front panel of the AIC-I indicate the status of the alarm contacts: one LED representing all the inputs and one LED representing all the outputs. External alarms (input contacts) are typically used for external sensors such as open doors, temperature sensors, flood sensors, and other environmental conditions. External controls (output contacts) are typically used to drive visual or audible devices such as bells and lights, but they can control other devices such as generators, heaters, and fans.

You can program each of the sixteen input alarm contacts separately. Choices include:

- Alarm on Closure or Alarm on Open
- Alarm severity of any level (Critical, Major, Minor, Not Alarmed, Not Reported)
- Service Affecting or Non-Service Affecting alarm-service level
- 63-character alarm description for CTC display in the alarm log

You cannot assign the fan-tray abbreviation for the alarm; the abbreviation reflects the generic name of the input contacts. The alarm condition remains raised until the external input stops driving the contact or you unprovision the alarm input.

The output contacts can be provisioned to close on a trigger or to close manually. The trigger can be a local alarm severity threshold, a remote alarm severity, or a virtual wire, as follows:

- Local NE alarm severity: A hierarchy of Not Reported, Not Alarmed, Minor, Major, or Critical alarm severities that you set to cause output closure. For example, if the trigger is set to Minor, a Minor alarm or above is the trigger.
- Remote NE alarm severity: Same as the local NE alarm severity but applies to remote alarms only.
- Virtual wire entities: You can provision any environmental alarm input to raise a signal on any virtual wire on external outputs 1 through 4 when the alarm input is an event. You can provision a signal on any virtual wire as a trigger for an external control output.

You can also program the output alarm contacts (external controls) separately. In addition to provisionable triggers, you can manually force each external output contact to open or close. Manual operation takes precedence over any provisioned triggers that might be present.

2.7.3 Orderwire

Orderwire allows a craftsperson to plug a phone set into an ONS 15454 SDH and communicate with craftspeople working at other ONS 15454 SDH nodes or other facility equipment. The orderwire is a pulse code modulation (PCM) encoded voice channel that uses E1 or E2 bytes in the MSOH and in the regenerator section overhead.

The AIC-I allows simultaneous use of both local (RSOH signal) and express (MSOH signal) orderwire channels on an SDH ring or particular optics facility. Express orderwire also allows communication through regeneration sites when the regenerator is not a Cisco device.

You can provision orderwire functions with CTC similar to the current provisioning model for GCC channels. In CTC, you provision the orderwire communications network during ring turn-up so that all network elements (NEs) on the ring can communicate with one another. Orderwire terminations (that is, the optics facilities that receive and process the orderwire channels) are provisionable. Both express and local orderwire can be configured as on or off on a particular SDH facility. The ONS 15454 SDH supports up to four orderwire channel terminations per shelf. This allows linear, single ring, dual ring, and small hub-and-spoke configurations. Keep in mind that orderwire is not protected in ring topologies such as multiplex section-shared protection ring (MS-SPRing) and subnetwork connection protection (SNCP).



Caution

Do not configure orderwire loops. Orderwire loops cause feedback that disables the orderwire channel.

The ONS 15454 SDH implementation of both local and express orderwire is broadcast in nature. The line acts as a party line. Anyone who picks up the orderwire channel can communicate with all other participants on the connected orderwire subnetwork. The local orderwire party line is separate from the express orderwire party line. Up to four STM-N facilities for each local and express orderwire are provisionable as orderwire paths.



Note

The OC3 IR 4/STM1 SH 1310 card does not support the EOW channel.

The AIC-I supports selective dual tone multifrequency (DTMF) dialing for telephony connectivity, which causes specific or all ONS 15454 SDH AIC-Is on the orderwire subnetwork to “ring.” The ringer/buzzer resides on the AIC-I. There is also a “ring” LED that mimics the AIC-I ringer. It flashes

when a call is received on the orderwire subnetwork. A party line call is initiated by pressing *0000 on the DTMF pad. Individual dialing is initiated by pressing * and the individual four-digit number on the DTMF pad. The station number of the node is provisioned in CTC.

The orderwire ports are standard RJ-11 receptacles. The pins on the orderwire ports correspond to the tip and ring orderwire assignments.

Table 2-19 describes the orderwire pin assignments.

Table 2-19 Orderwire Pin Assignments

RJ-11 Pin Number	Description
1	Four-wire receive ring
2	Four-wire transmit tip
3	Two-wire ring
4	Two-wire tip
5	Four-wire transmit ring
6	Four-wire receive tip

When provisioning the orderwire subnetwork, make sure that an orderwire loop does not exist. Loops cause oscillation and an unusable orderwire channel.

Figure 2-10 shows the standard RJ-11 connectors used for orderwire ports. Use a shielded RJ-11 cable.

Figure 2-10 RJ-11 Cable Connector

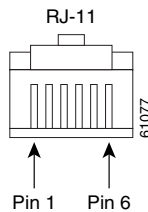

2.7.4 Power Monitoring

The AIC-I card provides a power monitoring circuit that monitors the supply voltage of –48 VDC for presence, undervoltage, or overvoltage.

2.7.5 User Data Channel

The UDC features a dedicated data channel of 64 kbps (F1 byte) between two nodes in an ONS 15454 SDH network. Each AIC-I card provides two UDCs, UDC-A and UDC-B, through separate RJ-11 connectors on the front of the AIC-I. Each UDC can be routed to an individual optical interface in the ONS 15454 SDH system. For instructions, refer to the “Create Circuits and Low-Order Tunnels” chapter in the *Cisco ONS 15454 SDH Procedure Guide*.

The UDC ports are standard RJ-11 receptacles. Table 2-20 lists the UDC pin assignments.

Table 2-20 UDC Pin Assignments

RJ-11 Pin Number	Description
1	For future use
2	TXN
3	RXN
4	RXP
5	TXP
6	For future use

2.7.6 Data Communications Channel

The DCC features a dedicated data channel of 576 kbps (D4 to D12 bytes) between two nodes in an ONS 15454 SDH network. Each AIC-I card provides two DCCs, DCC-A and DCC-B, through separate RJ-45 connectors on the front of the AIC-I. Each DCC can be routed to an individual optical interface in the ONS 15454 SDH system.

Note

DCC connections cannot be provisioned if DCC tunneling is configured on this span.

The DCC ports are standard RJ-45 receptacles. [Table 2-21](#) describes the GCC pin assignments.

Table 2-21 GCC Pin Assignments

RJ-45 Pin Number	Description
1	TCLKP
2	TCLKN
3	TXP
4	TXN
5	RCLKP
6	RCLKN
7	RXP
8	RXN

