



Add and Remove Nodes

This chapter explains how to add and remove Cisco ONS 15454 SDH nodes from multiplex section-shared protection rings (MS-SPRings), subnetwork connection protection (SNCP) rings, and linear add-drop multiplexer (ADM) configurations.

Before You Begin

Before performing any of the following procedures, complete the [“NTP-D195 Document Existing Provisioning” procedure on page 7-2](#). Also investigate all alarms and clear any trouble conditions. Refer to the *Cisco ONS 15454 SDH Troubleshooting Guide* as necessary.

This section lists the chapter procedures (NTPs). Turn to a procedure for applicable tasks (DLPs).

1. [NTP-D102 Add an MS-SPRing Node, page 14-2](#)—Complete as needed.
2. [NTP-D213 Remove an MS-SPRing Node, page 14-6](#)—Complete as needed.
3. [NTP-D105 Add an SNCP Node, page 14-9](#)—Complete as needed.
4. [NTP-D106 Remove an SNCP Node, page 14-11](#)—Complete as needed.
5. [NTP-D280 Add a Node to a Linear ADM Manually, page 14-12](#)—Complete as needed to add a node to the end of a linear ADM. This procedure can be used to add a node between two linear ADM nodes, but requires that circuits be deleted and recreated. To add a node without disrupting traffic, use the following procedure.
6. [NTP-D321 Add a Node to a Linear ADM Using the Wizard, page 14-14](#)—Complete as needed to add a node between two linear ADM nodes.
7. [NTP-D322 Remove an In-Service Node from a Linear ADM, page 14-17](#)—Complete as needed to remove a node from a linear ADM without disrupting traffic.

NTP-D102 Add an MS-SPRing Node

Purpose	This procedure expands an MS-SPRing by adding a node.
Tools/Equipment	Fiber for new node connections
Prerequisite Procedures	Cards must be installed and node turn-up procedures completed on the node that will be added to the MS-SPRing. See Chapter 2, “Install Cards and Fiber-Optic Cable,” and Chapter 4, “Turn Up Node.”
Required/As Needed	As needed
Onsite/Remote	Onsite
Security Level	Superuser



Caution

Adding an MS-SPRing node can be service affecting and should be performed during a maintenance window.

Step 1

Draw a diagram of the MS-SPRing where you will add the node. In the diagram, identify the east and west MS-SPRing STM-N trunk (span) cards that will connect to the new node. This information is essential to complete this procedure without error. [Figure 14-1](#) shows a drawing of a three-node, two-fiber MS-SPRing that uses Slots 5 and 12 for the MS-SPRing trunk cards. The dashed arrow shows the new fiber connections that will be made to add the fourth node to the MS-SPRing.

Figure 14-1 Three-Node, Two-Fiber MS-SPRing Before a Fourth Node Is Added

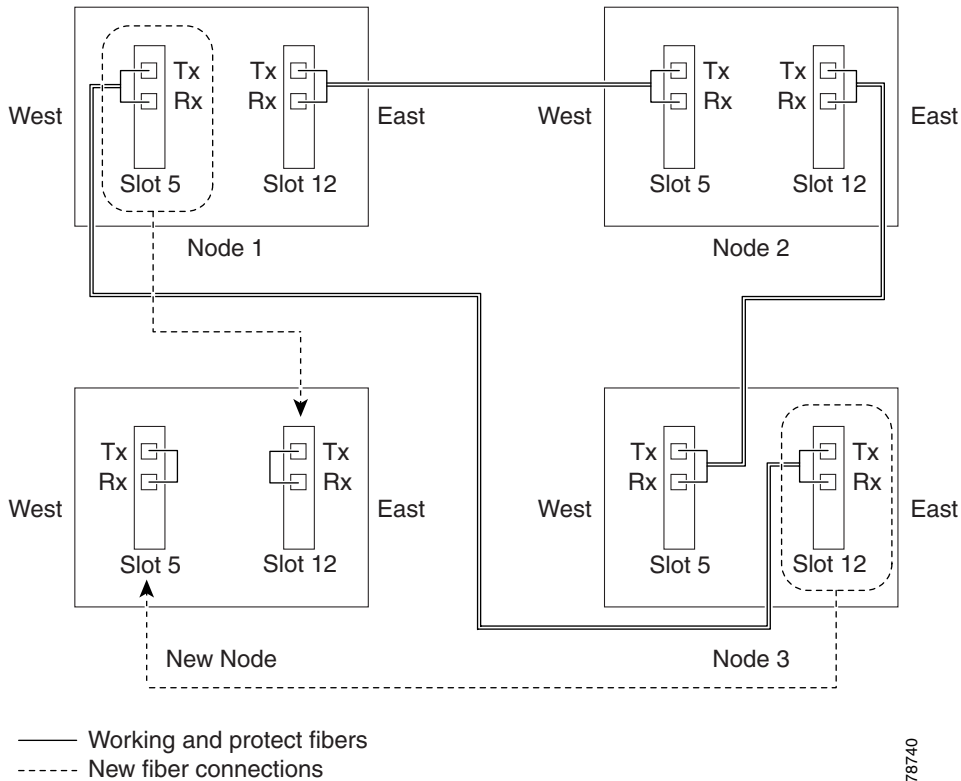
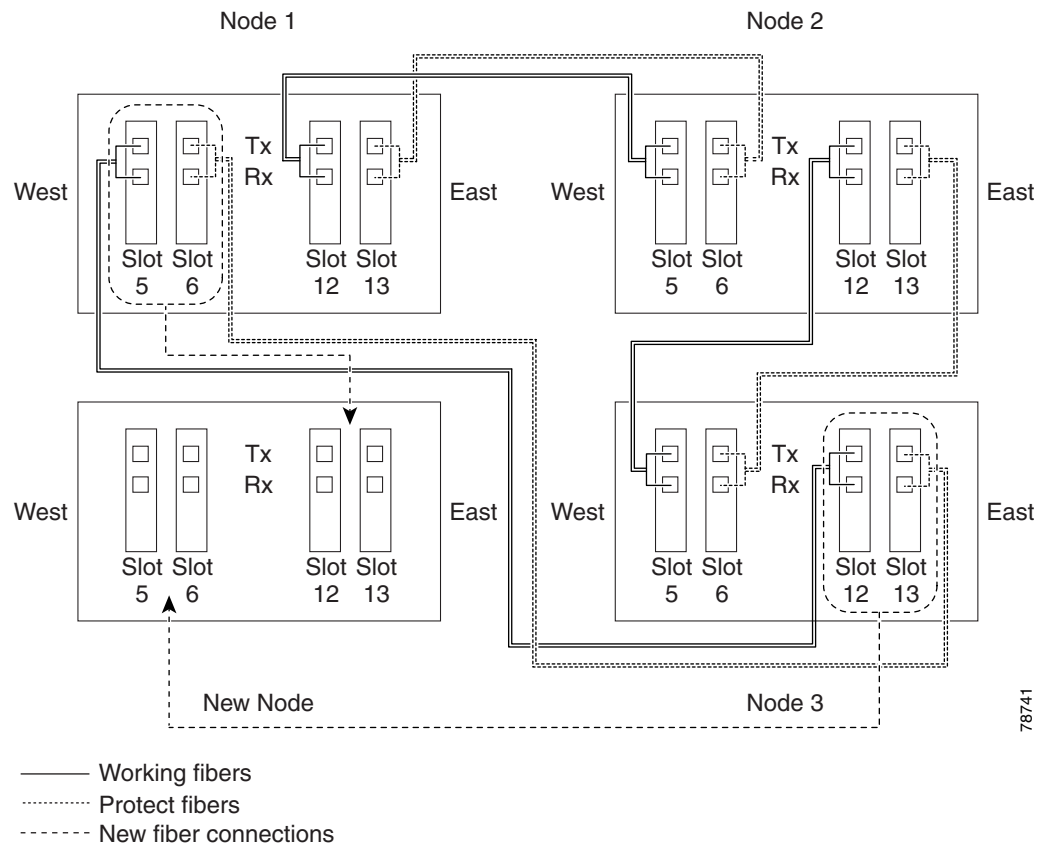

Figure 14-2 shows a sample drawing of a four-fiber MS-SPRing. The dashed arrow shows the new fiber connections that will be made to add the fourth node. For four-fiber MS-SPRings, two fiber sets will be reconnected, the working fiber and the protect fiber.

Figure 14-2 Three-Node, Four-Fiber MS-SPRing Before a Fourth Node is Added



- Step 2** According to local site practice, complete the “[NTP-D108 Back Up the Database](#)” procedure on [page 15-4](#) for all the nodes in the ring.
- Step 3** Verify the card installation on the new node using the “[NTP-D24 Verify Card Installation](#)” procedure on [page 4-2](#). Verify that the STM-N cards that will be the MS-SPRing trunk cards match the MS-SPRing optical rate. For example, if the MS-SPRing is STM-16, the new node must have STM-16 cards installed. If the STM-N cards are not installed or the optical rates do not match the MS-SPRing, complete the “[NTP-D16 Install the STM-N Cards](#)” procedure on [page 2-7](#).
- Step 4** Verify that fiber is available to connect the new node to the existing nodes. Refer to the diagram drawn in [Step 1](#).
- Step 5** Complete the “[NTP-D35 Verify Node Turn Up](#)” procedure on [page 5-2](#). In order to have CTC visibility to the new node after it is added, you must be an authorized user on the node and you must have IP connectivity to the node.
- Step 6** Check to see if the new node IP address is on the same subnet as other nodes in the network. If two or more PCs are directly connected to different nodes that belong to the same subnet and Craft Access Only is not checked under Gateway Settings, add static routes on the gateway ONS 15454 SDH nodes, using the following settings:
- Destination IP address: *Local-PC-IP-address*

- Net Mask: **255.255.255.255**
- Next Hop: *IP-address-of-the-Cisco-ONS-15454-SDH*
- Cost: **1**

See the “[DLP-D65 Create a Static Route](#)” task on page 17-54. To view Gateway Settings, see the “[DLP-D249 Provision IP Settings](#)” task on page 19-30.

- Step 7** Complete the “[DLP-D60 Log into CTC](#)” task on page 17-47 at a node that is in the MS-SPRing.
- Step 8** Complete the “[DLP-D298 Check the Network for Alarms and Conditions](#)” task on page 19-61 to verify that the MS-SPRing is free of major alarms or problems. If trouble is indicated (for example, a major alarm exists), resolve the problem before proceeding. See [Chapter 7, “Manage Alarms”](#) or, if necessary, refer to the *Cisco ONS 15454 SDH Troubleshooting Guide*.
- Step 9** Click the **Provisioning > MS-SPRing** tabs.
- Step 10** On paper, record the Ring ID, Ring Type, Line Rate, Ring Reversion, and Span Reversion (4 Fiber).
- Step 11** From the Node column, record the Node IDs in the MS-SPRing. The Node IDs are the numbers in parentheses next to the node name.
- Step 12** Log into the new node:
- If the node has a LAN connection and it appears on the network map, from the View menu, choose **Go to Other Node**, then enter the new node.
 - If the new node is not connected to the network, complete the “[DLP-D60 Log into CTC](#)” task on page 17-47.
- Step 13** Click the **Alarms** tab.
- Verify that the alarm filter is not on. See the “[DLP-D227 Disable Alarm Filtering](#)” task on page 19-18 as necessary.
 - Verify that no unexplained alarms appear on the network. If alarms appear, investigate and resolve them before continuing. Refer to the *Cisco ONS 15454 SDH Troubleshooting Guide* for procedures.
- Step 14** Using the information recorded in Steps 10 and 11 and the diagram created in [Step 1](#), create an MS-SPRing on the new node. See the “[DLP-D242 Create an MS-SPRing on a Single Node](#)” task on page 19-24.
- Step 15** (Optional.) Create test circuits, making sure they pass through the MS-SPRing trunk cards and run test traffic through the node to ensure the cards are functioning properly. See the “[NTP-D324 Create a Manually Routed High-Order Circuit](#)” procedure on page 6-45 and the “[NTP-D62 Test High-Order Circuits](#)” procedure on page 6-51 for information.
- Step 16** Create the data communications channel (DCC) terminations on the new node. See the “[DLP-D464 Provision Section DCC Terminations](#)” task on page 21-44.



Note Creating the DCC terminations causes the SDCC Termination Failure (EOC) and Loss of Signal (LOS) alarms to appear. These alarms remain active until you connect the node to the MS-SPRing.



Note If you map the K3 byte to another byte (such as E2), you must remap the trunk cards on either side of the new node to the same byte. See the “[DLP-D89 Remap the K3 Byte](#)” task on page 17-81.

- Step 17** Complete the “[DLP-D60 Log into CTC](#)” task on page 17-47 at an MS-SPRing node that will connect to the new node.
- Step 18** Referring to the diagram created in [Step 1](#), complete the “[DLP-D303 Initiate an MS-SPRing Force Ring Switch](#)” task on page 20-3 on the node that will connect to the new node on its west line (port). In the [Figure 14-2](#) example, the MS-SPRing force ring would occur at Node 1, West line (Slot 5 and 6).
- Step 19** Referring to the diagram created in [Step 1](#), complete the “[DLP-D303 Initiate an MS-SPRing Force Ring Switch](#)” task on page 20-3 on the node that will connect to the new node on its east line (port). In the [Figure 14-2](#) example, the MS-SPRing force ring would occur at Node 3, East line (Slots 12 and 13).
- Step 20** Click the **Alarms** tab.
- Verify that the alarm filter is not on. See the “[DLP-D227 Disable Alarm Filtering](#)” task on page 19-18 as necessary.
 - Verify that no unexplained alarms appear on the network. If alarms appear, investigate and resolve them before continuing. Refer to the *Cisco ONS 15454 SDH Troubleshooting Guide* for procedures.
- Step 21** Following the diagram created in [Step 1](#), remove the fiber connections from the two nodes that will connect to the new node.
- Remove the west fiber from the node that will connect to the east port of the new node. In the [Figure 14-1](#) example, this is Node 1, Slot 5, and in [Figure 14-2](#) this is Node 3, Slots 5 and 6.
 - Remove the east fiber from the node that will connect to the west port of the new node. In the [Figure 14-1](#) example, this is Node 3, Slot 12, and in [Figure 14-2](#) this is Node 1, Slots 12 and 13.
- Step 22** Connect fibers from the adjacent nodes to the new node following the diagram created in [Step 1](#). Connect the west port to the east port and the east port to the west port. For four-fiber MS-SPRings, connect the protect fibers.
- Step 23** After the newly added node appears in network view, double-click it to display the node in node view.
- Step 24** Click the **Provisioning > MS-SPRing** tabs.
- Step 25** Click **Ring Map**. Verify that the new node appears on the Ring Map with the other MS-SPRing nodes, then click **OK**.
- Step 26** From the View menu, choose **Go to Network View** and check the following:
- Click the **Provisioning > MS-SPRing** tabs. Verify that the new node appears in the Node column.
 - Click the **Alarms** tab. Verify that MS-SPRing alarms such as RING MISMATCH, E-W MISMATCH, PRC-DUPID (duplicate node ID), and APSCDFLTK (default K) do not appear.
- If the new node does not appear under the Node column, or if MS-SPRing alarms appear, log into the new node and verify that the MS-SPRing is provisioned on it correctly with the information from [Steps 10](#) and [11](#). If the node still does not appear, or if alarms persist, refer to the *Cisco ONS 15454 SDH Troubleshooting Guide*.
- Step 27** Click the **Circuits** tab. Wait until all the circuits are discovered. The circuits that pass through the new node will be shown as incomplete.
- Step 28** In network view, right-click the new node and choose **Update Circuits With The New Node** from the shortcut menu. Verify that the number of updated circuits that appear in the dialog box is correct.
- Step 29** If incomplete circuits still appear, refer to the *Cisco ONS 15454 SDH Troubleshooting Guide*.
- Step 30** Click the **History** tab. Verify that the MS-SPRing_RESYNC condition appears for every node in the MS-SPRing.
- Step 31** Complete the “[DLP-D194 Clear an MS-SPRing Force Ring Switch](#)” task on page 18-35 to remove the ring switch from the east and west MS-SPRing lines.

- Step 32** (Optional.) Complete the “[NTP-D175 Two-Fiber MS-SPRing Acceptance Test](#)” procedure on page 5-13.
Stop. You have completed this procedure.
-

NTP-D213 Remove an MS-SPRing Node

Purpose	This procedure removes a node from an MS-SPRing.
Tools/Equipment	None
Prerequisite Procedures	NTP-D41 Create the MS-SPRing , page 5-12
Required/As Needed	As needed
Onsite/Remote	Onsite
Security Level	Provisioning or higher



Caution

The following procedure minimizes traffic outages during node removals. You will delete all circuits that originate and terminate on the node that will be removed. You will also verify that they do not enter and exit the node on different VC4s and/or VC3s or VC12. If they do, you will delete and recreate the circuits, and traffic will be lost during this time.



Caution

If you remove a node that is the only building integrated timing supply (BITS) timing source for the ring, you also remove the only source of synchronization for all the nodes in that ring. Circuits that leave the ring to connect to other networks synchronized to a Stratum 1 clock will experience a high level of pointer adjustments, which might adversely affect traffic performance.

- Step 1** According to local site practice, complete the “[NTP-D108 Back Up the Database](#)” procedure on page 15-4 for all the nodes in the ring.
- Step 2** Complete the “[DLP-D195 Verify Timing in a Reduced Ring](#)” task on page 18-36.
- Step 3** Complete the “[DLP-D60 Log into CTC](#)” task on page 17-47 at the node you will remove. If you are already logged in, continue with Step 2.
- Step 4** Create a diagram of the MS-SPRing where you will remove the node. You can draw the MS-SPRing manually, or you can print it from CTC by performing the following steps:
- From the View menu, choose **Go to Network View**.
 - Click the **Provisioning > MS-SPRing** tabs.
 - Choose the desired MS-SPRing, then click **Edit**.
 - In the MS-SPRing window, verify that all the port information is visible. If not, press **Ctrl** and drag the node icons to a new location so the information can be viewed.
 - Complete the “[DLP-D429 Print CTC Data](#)” task on page 21-16.
 - Close the MS-SPRing window by choosing **Close** from the File menu.
- Step 5** Referring to the MS-SPRing diagram, identify the following:
- The node that is connected through its west port to the target (removal) node. For example, if you were removing Node 4 in [Figure 14-3](#), Node 1 is connected through its west port to Node 4.

- The node that is connected through its east port to the node that will be removed. In [Figure 14-3](#), Node 3 is connected through its east port to Node 4.

Write down the slot and port of the MS-SPRing in the node.

Figure 14-3 Four-Node, Two-Fiber MS-SPRing Before a Node Is Removed

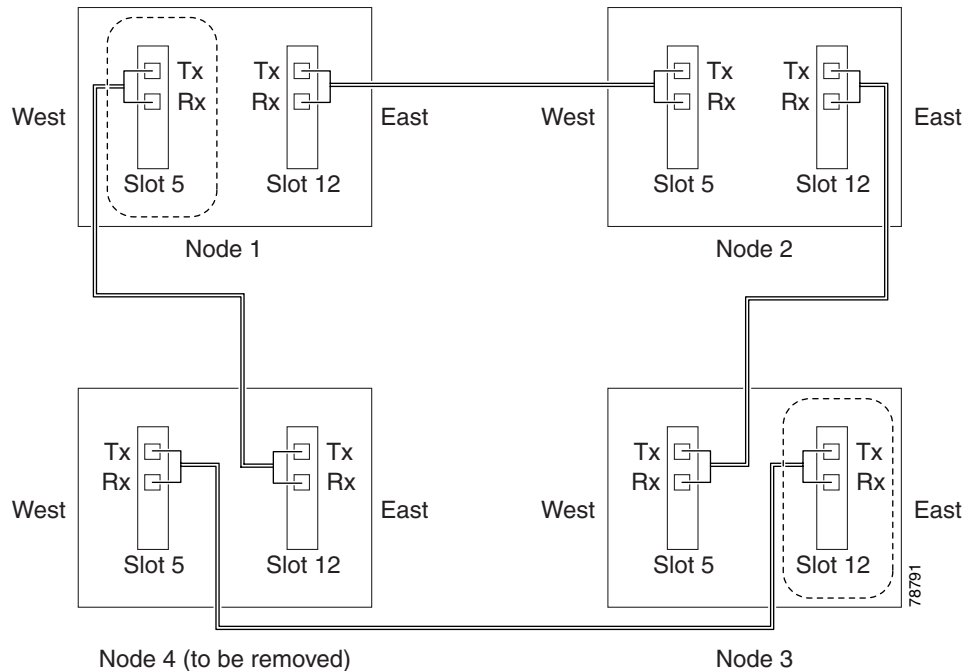

- Step 6** Complete the “[DLP-D298 Check the Network for Alarms and Conditions](#)” task on page 19-61 to verify that the MS-SPRing is free of major alarms or problems. If trouble is indicated (for example, if a major alarm exists), resolve the problem before proceeding. See [Chapter 7, “Manage Alarms”](#) or, if necessary, refer to the *Cisco ONS 15454 SDH Troubleshooting Guide*.
- Step 7** From the View menu, choose **Go to Other Node**. Choose the node that you will remove and click **OK**.
- Step 8** Click the **Circuits** tab. If the Scope setting is set to Network, choose **Node** from the Scope drop-down list. Make sure that the Filter button is off (not indented) to ensure that all circuits are visible.
- Step 9** Delete all circuits that originate or terminate on the node. See the “[DLP-D27 Delete Circuits](#)” task on page 17-21.
- Step 10** Complete the “[DLP-D357 Verify Pass-Through Circuits](#)” task on page 20-65 to verify that circuits passing through the node to be deleted enter and exit the node on the same VC4 and/or VC3 or VC12.
- Step 11** From the View menu, choose **Go to Network View**.
- Step 12** Referring to the diagram created in [Step 4](#), complete the “[DLP-D303 Initiate an MS-SPRing Force Ring Switch](#)” task on page 20-3 at each node that connects to the target (removal) node to force traffic away from it. You must perform a Force switch at each port connected to the target node. For example, in [Figure 14-3](#), you would perform a Force switch on the east port of Node 3 and the west port of Node 1.
- Step 13** Click the **Alarms** tab.
- Verify that the alarm filter is not on. See the “[DLP-D227 Disable Alarm Filtering](#)” task on page 19-18 as necessary.
 - Verify that no unexplained alarms appear on the network. If alarms appear, investigate and resolve them before continuing. Refer to the *Cisco ONS 15454 Troubleshooting Guide* for procedures.

- Step 14** Remove the fiber connections between the node being removed and the two neighboring nodes.
- Step 15** If the two nodes that will be connected after the MS-SPRing node is removed have OC48/STM16 AS trunk (span) cards and their K3 bytes were remapped, complete the [“DLP-D388 Verify MS-SPRing Extension Byte Mapping”](#) task on page 20-74. If not, continue with [Step 16](#).
- Step 16** Reconnect the fiber of the two neighboring nodes directly, west port to east port. For example, in [Figure 14-3](#), you would connect the east port of Node 3 (Slot 12) to the west port of Node 1 (Slot 5).
- Step 17** Complete the following substeps:
- From the View menu, choose **Go to Other Node**. Choose one of the newly connected nodes and click **OK**.
 - Click the **Provisioning > MS-SP Ring** tabs.
 - Choose the MS-SPRing that originally contained the removed node, and then click **Ring Map**.
 - Wait until the removed node is no longer listed.
 - Repeat steps **a** through **d** for the other newly connected node in the MS-SPRing.
- Step 18** Complete the [“DLP-D196 Delete an MS-SPRing from a Single Node”](#) task on page 18-37.
- Step 19** Click the **History** tab. Verify that the MSSPR_RESYNC condition appears for every node in the MS-SPRing.
- Step 20** Complete the [“DLP-D194 Clear an MS-SPRing Force Ring Switch”](#) task on page 18-35 to remove the Force protection switches.
- Step 21** According to local site practice, complete the [“NTP-D175 Two-Fiber MS-SPRing Acceptance Test”](#) procedure on page 5-13.
- Step 22** Complete the [“DLP-D79 Remove Pass-through Connections”](#) task on page 17-70.
- Step 23** Log back into a node on the reduced ring. In the CTC Login dialog box, uncheck the **Disable Network Discovery** check box.



Note The deleted node will appear in network view until all SDCC terminations are deleted. To delete SDCC terminations, complete the [“DLP-D156 Delete a Section DCC Termination”](#) task on page 18-23.

- Step 24** Click the **Circuits** tab and verify that no incomplete circuits are present. If incomplete circuits appear, repeat Steps [22](#) and [23](#).
- Step 25** If you delete a node that was in a login node group, you will see incomplete circuits for that node in the CTC network view. Although it is no longer part of the ring, the removed node still reports to CTC until it is no longer in a login node group. If necessary, complete the [“DLP-D54 Delete a Node from a Specified Login Node Group”](#) task on page 17-44.
- Step 26** To remove another node from a MS-SPRing, repeat this procedure for that node.

Stop. You have completed this procedure.

NTP-D105 Add an SNCP Node

Purpose	This procedure adds a node to an SNCP ring.
Tools/Equipment	None
Prerequisite Procedures	Cards must be installed and node turn-up procedures completed on the node that will be added to the SNCP ring. See Chapter 2, “Install Cards and Fiber-Optic Cable,” and Chapter 4, “Turn Up Node.”
Required/As Needed	As needed
Onsite/Remote	Onsite
Security Level	Superuser

-
- Step 1** According to local site practice, complete the [“NTP-D108 Back Up the Database” procedure on page 15-4](#) for all the nodes in the ring.
- Step 2** Log into an existing node in the SNCP where you want to add a node. See the [“DLP-D60 Log into CTC” task on page 17-47](#) for instructions. In order to have CTC visibility to the new node after it is added, you must be an authorized user on the node and you must have IP connectivity to the node.
- Step 3** Complete the [“DLP-D298 Check the Network for Alarms and Conditions” task on page 19-61](#) to verify that the SNCP is free of major alarms or problems. If trouble is indicated (for example, a major alarm exists), resolve the problem before proceeding. See [Chapter 7, “Manage Alarms”](#) or, if necessary, refer to the *Cisco ONS 15454 SDH Troubleshooting Guide*.
- Step 4** Verify the card installation on the new node. See the [“NTP-D24 Verify Card Installation” procedure on page 4-2](#). Check that the STM-N cards that will serve as the SNCP trunk (span) cards match the SNCP optical rate of the trunk cards to which the new node will be connected. For example, if the adjacent nodes have STM-16 trunk cards, the new node must have STM-16 cards installed. If the STM-N cards are not installed or the rate does not match the rate of the adjacent node trunk cards, complete the [“NTP-D16 Install the STM-N Cards” procedure on page 2-7](#) to install them.
- Step 5** Verify that fiber is available to connect the new node to the existing nodes.
- Step 6** Complete the [“NTP-D35 Verify Node Turn Up” procedure on page 5-2](#).
- Step 7** Determine if the following conditions are present.
- The IP address for the new node is on the same subnet as other nodes in the network.
 - On the new node Provisioning > Network > General subtab, Craft Access Only is not checked under Gateway Settings.
 - A CTC computer is directly connected to the new node.
 - CTC computers are directly connected to other nodes on the same subnet.
- If the conditions are not present, continue with [Step 8](#). If conditions are present, complete the [“DLP-D65 Create a Static Route” task on page 17-54](#) on the node that will be added to the SNCP. Use the following settings:
- Destination IP address: *IP-address-of-the-CTC-computer-connected-to-the-new-node*
 - Net Mask: **255.255.255.255**
 - Next Hop: *IP-address-of-the-Cisco-ONS-15454-SDH*
 - Cost: **1**
- To view Gateway Settings, see the [“DLP-D249 Provision IP Settings” task on page 19-30](#).
- Step 8** Log into the new node:

- If the node has a LAN connection and it appears on the network map, from the View menu, choose **Go to Other Node**, then enter the new node.
 - If the new node is not connected to the network, complete the “[DLP-D60 Log into CTC](#)” task on [page 17-47](#).
- Step 9** Click the **Alarms** tab. Verify that no critical or major alarms are present, nor any facility alarms, such as LOS, LOF, AIS-L, SF, and SD. If trouble is indicated (for example, a major alarm exists), resolve the problem before proceeding. See [Chapter 7, “Manage Alarms”](#) or, if necessary, refer to the *Cisco ONS 15454 SDH Troubleshooting Guide*.
- Step 10** (Optional.) Create test circuits, making sure that they pass through the SNCP trunk (span) cards, and run test traffic through the node to ensure that the cards are functioning properly. See the “[NTP-D324 Create a Manually Routed High-Order Circuit](#)” procedure on [page 6-45](#) and the “[NTP-D62 Test High-Order Circuits](#)” procedure on [page 6-51](#) for information.
- Step 11** Create the DCC terminations on the new node. See the “[DLP-D464 Provision Section DCC Terminations](#)” task on [page 21-44](#).
- Step 12** From the View menu, choose **Go to Network View**.
- Step 13** Complete the “[DLP-D197 Initiate an SNCP Force Switch](#)” task on [page 18-37](#) to switch traffic away from the span that will be broken to connect to the new node.
- Step 14** Two nodes will connect directly to the new node; remove their fiber connections:
- a. Remove the east fiber connection from the node that will connect to the west port of the new node.
 - b. Remove the west fiber connection from the node that will connect to the east port of the new node.
- Step 15** Replace the removed fibers with the fibers that are connected to the new node.
- Step 16** Log out of CTC and log back into a node in the network.
- Step 17** From the View menu, choose **Go to Network View** to display the SNCP nodes. The new node should appear in the network map. Wait for a few minutes to allow all the nodes to appear.
- Step 18** Click the **Circuits** tab and wait for all the circuits to appear, including spans. Count the number of incomplete circuits.
- Step 19** In the network view, right-click the new node and choose **Update Circuits With New Node** from the shortcut menu. Wait for the confirmation dialog box to appear. Verify that the number of updated circuits that appears in the dialog box is correct.
-
-  **Note** If the circuits take more than a minute to appear, log out, then log back in.
-
- Step 20** Click the **Circuits** tab and verify that no incomplete circuits appear.
- Step 21** Complete the “[DLP-D198 Clear an SNCP Force Switch](#)” task on [page 18-38](#) to clear the protection switch.
- Step 22** Complete the “[NTP-D177 SNCP Acceptance Test](#)” procedure on [page 5-22](#).
- Stop. You have completed this procedure.**
-

NTP-D106 Remove an SNCP Node

Purpose	This procedure removes a node from an SNCP ring.
Tools/Equipment	None
Prerequisite Procedures	NTP-D44 Provision SNCP Nodes, page 5-21
Required/As Needed	As needed
Onsite/Remote	Onsite
Security Level	Provisioning or higher



Caution

The following procedure minimizes traffic outages during node removals.



Caution

If you remove a node that is the only BITS timing source for the ring, you also remove the only source of synchronization for all the nodes in that ring. Circuits that connect to other networks which are synchronized to a Stratum 1 clock will experience a high level of pointer adjustments, which might adversely affect customer service.

-
- Step 1** Draw a diagram of the SNCP ring where you will remove the node. In the diagram, identify the following:
- The node that is connected through its west port to the node that will be removed.
 - The node that is connected through its east port to the node that will be removed.
- Step 2** Complete the “[DLP-D60 Log into CTC](#)” task on page 17-47 at a node in the network where you want to remove a SNCP node.
- Step 3** Complete the “[DLP-D298 Check the Network for Alarms and Conditions](#)” task on page 19-61 to verify that the SNCP ring is free of major alarms or problems. If trouble is indicated (for example, a major alarm exists), resolve the problem before proceeding. See [Chapter 7, “Manage Alarms”](#) or, if necessary, refer to the *Cisco ONS 15454 SDH Troubleshooting Guide*.
- Step 4** Complete the “[DLP-D27 Delete Circuits](#)” procedure on page 17-21 for circuits that originate or terminate in the node you will remove. (If a circuit has multiple drops, delete only the drops that terminate on the node you are deleting.)
- Step 5** Complete the “[DLP-D357 Verify Pass-Through Circuits](#)” task on page 20-65 to verify that circuits passing through the node to be deleted enter and exit the node on the same VC4 and/or VC3 or VC12.
- Step 6** Complete the “[DLP-D197 Initiate an SNCP Force Switch](#)” task on page 18-37 for all spans connected to the node you are removing.
- Step 7** Remove all fiber connections between the node being removed and the two neighboring nodes.
- Step 8** Reconnect the fiber of the two neighboring nodes directly, west port to east port.
- Step 9** If you delete a node that was in a login node group, you will see incomplete circuits for that node in the CTC network view. (Although it is no longer part of the ring, the removed node still reports to CTC until it is no longer in a login node group.) Delete the node from the login node group:
- From the CTC Edit menu, choose **Preferences**.
 - In the Preferences dialog box, click the **Login Node Groups** tab.
 - Click the login node group tab containing the node you want to remove.

- d. Click the node you want to remove, then click **Remove**.
 - e. Click **OK**.
- Step 10** Exit CTC and log back in. See the “[DLP-D60 Log into CTC](#)” task on page 17-47 for instructions.
- Step 11** Log into each newly connected node and open the Alarms tab. Verify that the span cards are free of alarms. Resolve any alarms before proceeding. Refer to the *Cisco ONS 15454 SDH Troubleshooting Guide*.
- Step 12** Complete the “[DLP-D195 Verify Timing in a Reduced Ring](#)” task on page 18-36.
- Step 13** Complete the “[DLP-D198 Clear an SNCP Force Switch](#)” task on page 18-38 to clear the protection switch.
- Step 14** Click the **Circuits** tab and verify that no incomplete circuits appear.
- Step 15** (Optional.) Complete the “[NTP-D177 SNCP Acceptance Test](#)” procedure on page 5-22.
- Stop. You have completed this procedure.**
-

NTP-D280 Add a Node to a Linear ADM Manually

Purpose	This procedure adds a single ONS 15454 SDH node to the end of an ONS 15454 SDH linear add/drop multiplexer (ADM) network. If the linear ADM carries traffic, you cannot add a node between two linear ADM nodes using this procedure unless you delete and recreate the circuits. To avoid deleting and recreating the circuits, use the “ NTP-D321 Add a Node to a Linear ADM Using the Wizard ” procedure on page 14-14 to add a node between two linear ADM nodes.
Tools/Equipment	None
Prerequisite Procedures	NTP-D38 Provision a Linear ADM Network , page 5-6
Required/As Needed	As needed
Onsite/Remote	Onsite
Security Level	Provisioning or higher



Note

Optical transmit and receive levels should be in their acceptable range as shown in the specifications section for each card in [Table 2-3 on page 2-15](#).



Note

In a linear ADM configuration, two STM-N cards in 1+1 protection are connected to two STM-N cards in 1+1 protection on a second node. On the second node, two more STM-N cards are connected to a third node. The third node can be connected to a fourth node, and so on, depending on the number of nodes in the linear ADM. Slots 1 to 4 and 14 to 17 or Slots 5 to 6 and 12 to 13 can be used if connections between nodes are consistent. For example, Slot 5 on the first linear ADM node connects to Slot 5 on the second linear ADM node for the working path, and Slot 6 connects to Slot 6 for the protect path. The working STM-N ports have DCC terminations, and the STM-N cards are in a 1+1 protection group.

**Caution**

If the linear ADM carries traffic, you cannot add a node between two linear nodes unless you delete and recreate the circuits. Use this procedure to add a node to the end of the linear ADM.

- Step 1** At the new node, complete one of the following procedures:
- If the node has not been turned up, complete all procedures in [Chapter 4, “Turn Up Node.”](#)
 - If the node has been turned up, complete the [“NTP-D35 Verify Node Turn Up” procedure on page 5-2.](#)
- Step 2** Verify that the new node has two STM-N cards with the same rate as the linear ADM. If the STM-N cards are not installed, complete the [“NTP-D16 Install the STM-N Cards” procedure on page 2-7.](#)
- Step 3** Complete [“DLP-D73 Create a 1+1 Protection Group” task on page 17-63](#) for the two STM-N cards that will connect to the linear ADM node.
- Step 4** Complete the [“DLP-D464 Provision Section DCC Terminations” task on page 21-44](#) for the working STM-N card at the new node. Make sure to set the port state in the Create SDCC Termination dialog box to **Unlocked**. (Do not create a DCC termination on the protect card.)

**Note**

DCC failure alarms appear until you create DCC terminations in the linear ADM node and connect the fiber during [Step 11](#).

- Step 5** Complete the [“DLP-D60 Log into CTC” task on page 17-47](#) at the linear ADM node that will connect to the new node. If you are already logged in, continue with [Step 6](#).
- Step 6** Complete the [“DLP-D298 Check the Network for Alarms and Conditions” task on page 19-61.](#)
- Step 7** Install the STM-N cards that will connect to the new node. See [“NTP-D16 Install the STM-N Cards” procedure on page 2-7.](#) If the cards are already installed, continue with [Step 8](#).
- Step 8** Connect the working card at the existing linear ADM node to the working card at the new node. See [“DLP-D22 Install Fiber-Optic Cables in a 1+1 Configuration” procedure on page 17-17.](#)
- Step 9** Connect the protect card at the existing linear ADM node to the protect card at the new node.
- Step 10** Complete [“DLP-D73 Create a 1+1 Protection Group” task on page 17-63](#) for the two STM-N cards that connect to the new node.
- Step 11** Complete the [“DLP-D464 Provision Section DCC Terminations” task on page 21-44](#) for the working STM-N card that connects to the working card on the new node. Make sure to set the port state in the Create SDCC Termination dialog box to **Unlocked**. (Do not create a DCC termination for the protect card.)
- Step 12** From the View menu, choose **Go to Network View**. Verify that the newly created linear ADM configuration is correct. Two green span lines should appear between each linear node.
- Step 13** Complete the [“DLP-D298 Check the Network for Alarms and Conditions” task on page 19-61](#) to verify that no unexpected alarms or conditions are present.

Stop. You have completed this procedure.

NTP-D321 Add a Node to a Linear ADM Using the Wizard

Purpose	This procedure adds a node between two nodes in a 1+1 protection group without losing traffic.
Tools/Equipment	Compatible hardware necessary for the upgrade (for example, XC10G, XC-VXL-2.5G, and XC-VXL-10G cards and OC48 /STM16 any slot cards) Attenuators might be needed for some applications.
Prerequisite Procedures	The in-service topology upgrade procedure requires that the node to be added is reachable (has IP connectivity with CTC). Two technicians who can communicate with each other during the upgrade might be needed if the PC running CTC and the ONS 15454 SDH nodes are not at the same location.
Required/As Needed	As needed
Onsite/Remote	Onsite
Security Level	Provisioning or higher



Note STM-N transmit and receive levels should be in their acceptable range as shown in the specifications for each card in the [Table 2-3 on page 2-15](#).



Note If overhead circuits exist on the network, an in-service topology upgrade is service affecting. The overhead circuits will drop traffic and have a status of PARTIAL after the upgrade is complete.

- Step 1** Complete the “[DLP-D60 Log into CTC](#)” task on [page 17-47](#) at one of the nodes in the 1+1 protection group.
- Step 2** From the View menu choose **Go to Network View**.
- Step 3** On the network map, right-click the span between the two nodes where you want to add the new node. A dialog box appears.
- Step 4** Select **Upgrade Protection**. A drop-down list appears.
- Step 5** Select **Terminal to Linear** and the first page of the Upgrade Protection: Terminal to Linear dialog box appears.
- Step 6** The dialog box lists the following conditions for adding a new node:
 - The terminal network has no critical or major alarms.
 - The node that you will add has no critical or major alarms.
 - The node has compatible software version with that of the terminal nodes.
 - The node has four unused optical ports matching the speed of the 1+1 protection and no DCC has been provisioned on these four ports.
 - Fiber is available to connect the added node to the terminal nodes.

If all of these conditions are met and you wish to continue with the procedure, click **Next**.

**Note**

If you are attempting to add an unreachable node, you must first log in to the unreachable node using a separate CTC session and configure that node. Delete any existing protection groups as described in “DLP-D155 Delete a Protection Group” task on page 18-23 “Delete any existing SONET DCC terminations as described in the “DLP-D156 Delete a Section DCC Termination” task on page 18-23.

- Step 7** Choose the name of the new node in the drop-down list. If the node you want to add is not in the drop-down list, you can type in the name. If you type in the name, make sure it is identical to the actual node name. The node name is case sensitive.
- Step 8** Click **Next**. the Select Protection Group Ports page (Figure 14-4) appears.

Figure 14-4 Selecting Protection Group Ports

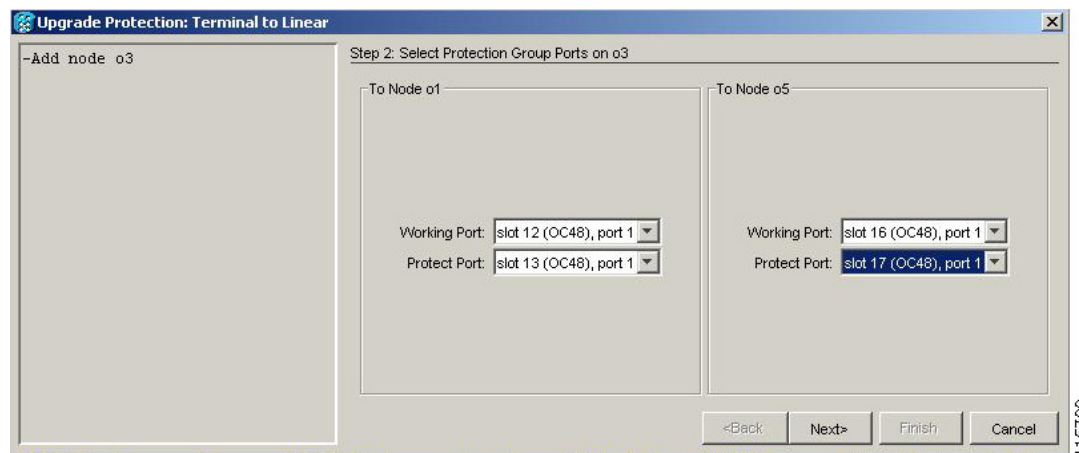

- Step 9** Select the working and protect ports on the new node that you want to connect to each terminal node from the drop-down lists. Click **Next**.
- Step 10** The Re-fiber the Protected Path dialog box appears (Figure 14-5). Follow the instructions in the dialog box for connecting the fibers between the nodes.

Figure 14-5 Refibering the Protect Path

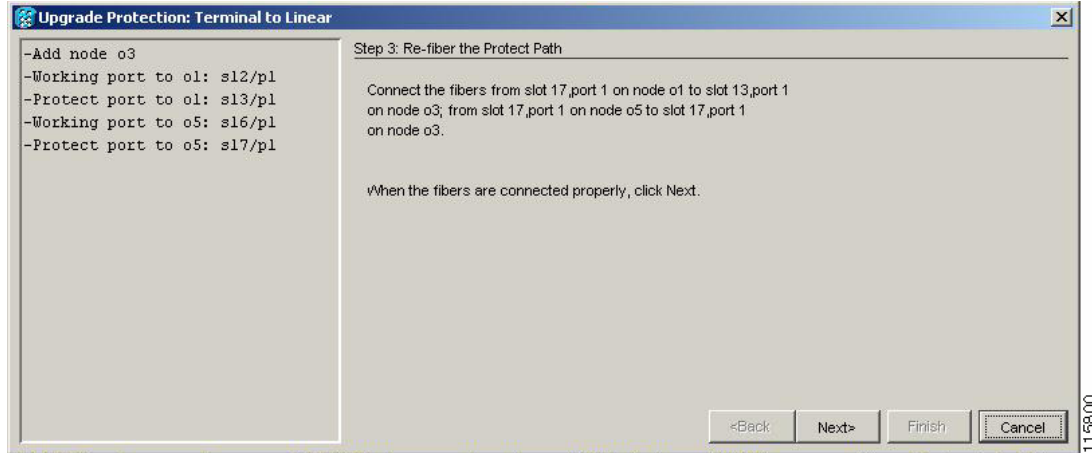

- Step 11** When the fibers are connected properly, click **Next**, and the Update Circuit(s) on *Node-Name* dialog box appears.

**Note**

The Back button is not enabled in the wizard. You can click the **Cancel** button at this point and choose the **Yes** button if you want to cancel the upgrade protection procedure. If the procedure fails after you have physically moved the fiber-optic cables you will need to restore the fiber-optic cables to the original positions and verify through CTC that traffic is on the working path of the nodes before restarting the process. To check traffic status, go to node view and click the **Maintenance > Protection** tabs. In the Protection Groups area, click the 1+1 protection group. You can see the status of the traffic in the Selected Group area.

- Step 12** Click **Next** on the Update Circuit(s) on *Node-Name* page to continue with the procedure.
- Step 13** The Force Traffic to Protect Path page states that it is about to force the traffic from the working to protect path for the terminal nodes. When you are ready to proceed, click **Next**.
- Step 14** Follow each step as instructed by the wizard as it guides you through the process of re-fibering the working path between nodes and forcing the traffic back to the working path.
- Step 15** The Force Traffic to Working Path page states that it is about to force the traffic from the protect to working path for the terminal nodes. When you are ready to proceed, click **Next**.
- Step 16** The Completed page appears. This page is the final one in the process. Click **Finish**.
- Stop. You have completed this procedure.**

NTP-D322 Remove an In-Service Node from a Linear ADM

Purpose	This procedure removes a single ONS 15454 SDH from a linear ADM without disrupting traffic.
Tools/Equipment	None
Prerequisite Procedures	NTP-D38 Provision a Linear ADM Network, page 5-6
Required/As Needed	As needed
Onsite/Remote	Onsite
Security Level	Provisioning or higher

Note

The 1+1 protection group must be uni-directional in order to delete a node from a linear ADM. If your 1+1 protection group is bi-directional, see the “[DLP-D154 Modify a 1+1 Protection Group](#)” task on [page 18-22](#) to change it to unidirectional. After you have removed the node from the linear group you can then change the protection setting back to bidirectional.

-
- Step 1** Complete the “[DLP-D60 Log into CTC](#)” task on [page 17-47](#) at a node in the network where you will remove the node.
- Step 2** From the View menu, choose **Go to Network View**.
- Step 3** Click the **Alarms** tab.
- Verify that the alarm filter is not on. See the “[DLP-D227 Disable Alarm Filtering](#)” task on [page 19-18](#) as necessary.
 - Verify that no unexplained alarms appear on the network. If unexplained alarms appear, resolve them before continuing. Refer to the *Cisco ONS 15454 SDH Troubleshooting Guide* if necessary.
- Step 4** Click the **Conditions** tab. Verify that no unexplained conditions appear on the network. If unexplained conditions appear, resolve them before continuing. Refer to the *Cisco ONS 15454 SDH Troubleshooting Guide* if necessary.
- Step 5** On the network map, double-click a node in the 1+1 protection group that is adjacent to the node you intend to remove from the group (the target node).
- Step 6** In node view, click the **Maintenance > Protection** tabs.
- Step 7** Initiate a Force switch on the working port:
- In the Protection Groups area, click the 1+1 protection group.
 - In the Selected Group area, click the working port.
 - Next to Switch Commands, click **Force**.
 - In the Confirm Force Operation dialog box, click **Yes**.
 - In the Selected Group area, verify that the following appears:
 - Protect port - Protect/Active [FORCE_SWITCH_TO_PROTECT] [PORT STATE]
 - Working port - Working/Standby [FORCE_SWITCH_TO_PROTECT], [PORT STATE]
- Step 8** Repeat [Step 5](#) through [Step 7](#) for the node that is connected directly to the other side of the target node.
- Step 9** Remove the fiber from the working ports of the target node.
- Step 10** Connect the fiber between the working ports of the two nodes that were directly connected to either side of the target node.

- Step 11** On the node where you initiated a Force switch in [Step 8](#), clear the switch:
- Next to Switch Commands, click **Clear**.
 - In the Confirm Clear Operation dialog box, click **Yes**.
- Step 12** Initiate a Force switch on the protect port:
- In the Selected Group area, click the protect port. Next to Switch Commands, click **Force**.
 - In the Confirm Force Operation dialog box, click **Yes**.
 - In the Selected Group area, verify that the following appears:
 - Protect port - Protect/Standby [FORCE_SWITCH_TO_WORKING], [PORT STATE]
 - Working port - Working/Active [FORCE_SWITCH_TO_WORKING], [PORT STATE]
- Step 13** From the View menu, choose **Go to Network View**.
- Step 14** On the network map, double-click the other node where you initiated a Force switch.
- Step 15** In node view, click the **Maintenance > Protection** tabs.
- Step 16** Clear the Force switch on the working port:
- In the Protection Groups area, click the 1+1 protection group.
 - In the Selected Group area, click the working port.
 - Next to Switch Commands, click **Clear**.
 - In the Confirm Clear Operation dialog box, click **Yes**.
- Step 17** Complete [Step 12](#) to initiate a Force switch on the protect port.
- Step 18** Remove the fiber from the protect ports on the target node.
- Step 19** Connect the fiber between the protect ports of the two nodes on each side of the target node.
- Step 20** Clear the Force switch:
- Next to Switch Commands, click **Clear**.
 - In the Confirm Clear Operation dialog box, click **Yes**.
 - In the Selected Group area, verify the following states:
 - Protect port - Protect/Standby
 - Working port - Working/Active
- Step 21** Repeat [Step 13](#) through [Step 16](#) to clear the switch on the other node.
- Step 22** Exit CTC.
- Step 23** Relaunch CTC at any one of the nodes that were adjacent to the target node. The nodes will now show the circuit status as DISCOVERED when checked.
- Stop. You have completed this procedure.**
-