

# Allegiance for Mobile Backhaul Unification

## Abstract

This white paper summarizes the demand for, and guidance regarding, architectural changes to mobile backhaul networks necessary to meet projected mobile broadband growth from 2011 to 2015. The paper is a joint effort derived from the combined expertise and insights of Cisco and NEC, which have joined forces to offer a world-leading, comprehensive mobile backhaul solution.

## 1. Introduction

### Mobile Backhaul: Network and Capacity Trends

Mobile networks have been experiencing unprecedented exponential growth in demand for mobile broadband and mobile Internet since the introduction of the iPhone. This mobile Internet phenomenon is global and continues to spread.

Although there are variances per country and per operator in the timeline and in the extent to which operators are willing or able to address this sea change for mobile Internet demand, one thing is universally agreed upon: Mobile backhaul networks appear to be most vulnerable to this change and must be reengineered and rearchitected to handle the new capacity and service demands.

Due to the critical and complex nature of mobile backhaul, and the challenges that a single vendor would face in building an optimal solution alone, NEC and Cisco have formed an alliance to validate a joint mobile backhaul solution.

Before discussing the joint solution, architectural trends, and proposed practices for mobile backhaul networks to handle the new service demands, let us offer some quantitative insight into the scale of projected change, as tracked through the Cisco<sup>®</sup> Visual Networking Index.

### Cisco Visual Network Index: 26-Fold Traffic Increase

The Cisco Visual Networking Index (VNI) is the most widely adopted and reputable forecasting initiative in the industry, and is used to project the expected growth and volume of network traffic during a specific time period. The index is derived from live network analytics from hundreds of operator networks around the planet, and combines real-time data with aggregated historical data and operator forecasting models.

The current Cisco VNI forecast shows that mobile networks will experience a more than 26-fold increase (26 times) in traffic between 2010 and 2015, and that video will be the major component of this traffic increase. A Cisco white paper, [Cisco Visual Networking Index: Global Mobile Data Traffic Forecast Update, 2010-2015](#), offers the following insight:

- **Global mobile data traffic grew 2.6-fold in 2010, nearly tripling for the third year in a row.**
- **Last year's mobile data traffic was three times the size of the entire global Internet in 2000.**
- **Mobile video traffic will exceed 50 percent of overall data traffic for the first time in 2011.**
- **There were 94 million laptops on the mobile network in 2010, and each laptop generated 22 times more traffic than the average smartphone.**
- **Global mobile data traffic will increase 26-fold between 2010 and 2015.**
- **Mobile network connection speeds will increase 10-fold by 2015.**

Overall mobile data traffic is expected to grow to 6.3 exabytes (EB) per month by 2015, a 26-fold increase over 2010 (Figure 1). Mobile data traffic will grow at a compound annual growth rate (CAGR) of 92 percent from 2010 to 2015. Annual growth rates will taper over the forecast period, from 131 percent in 2011 to 64 percent in 2015.

**Figure 1:** Cisco Forecasts 6.3 Exabytes of Mobile Data Traffic per Month by 2015

## The World is on the Move By 2015....



Clearly traditional circuit-oriented voice backhaul networks were not built with these mobile data forecasts in mind. As such, the traditional backhaul networks must be reengineered to manage this exponential growth. We will now offer some insight into network transformation trends across the backhaul industry.

## 2. Quantum Network Transformation

Despite widely adopted standardization from the GSMA, nearly every mobile operator has customized, unique, network architectures and deployments - no two networks are the same. Moreover, mobile networks have never been static, (they're mobile after all), and each is a rather complex amalgamation of multivendor equipment, some old, some new. As such, from the very beginning, mobile networks have been undergoing almost constant change.

The mobile Internet sea change described in the preceding section is producing a completely different demand for changes to the mobile network. The linear changes of the past decade to evolve the mobile voice circuit-switched network are no longer viable. The traditional approaches to scaling, which involve simply allocating additional point-to-point network circuit resources, must change. The networks now need to be built to scale according to **services and mobile applications**, and these are being introduced and adopted in nonlinear, quantum leaps.

In order to accommodate these nonlinear, quantum increases in demand on the network, the mobile networks must undergo a nonlinear, quantum transformation, all the way from the physical transport mechanisms to the mobile network architecture, and even into the network and service management systems.

## IP Transformation

IP has proven to be the successful foundation for the fixed Internet. Fixed-line service providers began the journey for IP transformation long ago, and most every public switched telephone network (PSTN) in the world is currently built upon an IP/Multiprotocol Label Switching (MPLS) foundation. Far more than just a technology protocol, IP has been the basis for widespread adoption of multiservice applications, ranging from consumer voice and video applications to secure enterprise business collaboration and massive online retail and commercial business-to-business applications.

Although there has already been widespread adoption of IP across fixed network service providers, these networks are missing a fundamental attribute that people around the world rely on - mobility. But that is about to change the world over, thanks to advances in both radio technology and networking technology that open the door for a mobile Internet revolution.

The mass market has already rewarded the insightful earlier adopters who are rolling out mobile Internet services with their business and their loyalty. The race is on for wide-scale IP transformation, and there is no turning back to circuit-oriented, point-to-point, voice-only networks. Such networks are overly restrictive, closed, and too costly to remain competitive as platforms for the multitrillion-dollar industry of global communications and entertainment. The question is no longer whether IP transformation is going to happen, or whether it is necessary; the only viable business question now is where and how to undergo IP transformation.

The remainder of this paper is dedicated to highlighting the rationale for where and how to tackle the business challenge of IP transformation toward a mobile Internet, with specific emphasis on the mobile backhaul network, starting from a mobile operator's traditional network.

We mention this viewpoint (that of a mobile operator) because, given mass market demand for mobile Internet services, fixed-mobile convergence is underway, and nonmobile service providers are also pursuing techniques to modify their existing IP networks into foundations for mobile backhaul and the mobile Internet.

Although this paper does not address the nuances of fixed-mobile convergence, such as DSL or cable, the baseline propositions are applicable for any mobile backhaul network.

## Mobile IP Transformation: From Core to Cell

Because mobile operators have long offered services that must interoperate across multiple networks, including fixed-line networks, as well as Internet gateways, the mass majority of mobile operators already have built and operate IP core and IP peering gateways in their core network.

What is new and different in 2011 is that the demand for scaling (the 26-fold increase discussed previously) and for offering mobile Internet services (mass market video, business-to-business collaboration and commerce, etc.) cannot be met simply by scaling up existing IP core networks. The scale of change is so large, and the array of new applications so dynamic, that the only way to meet the new market demand is to review the entire network architecture from the ground up. "From the ground up" means changes such as:

- Physical media, such as copper and low-capacity time-division multiplexing (TDM) microwave, to optical fiber and next-generation high-capacity packet microwave
- Protocol media, from TDM and synchronous digital hierarchy (SDH) to IP and Ethernet, in the radio as well as the backhaul network
- Full-scale changes in the network architecture, from hub and spoke or point-to-point topologies to ring and meshed network topologies

Although the entire network needs to be reworked, with every key subsystem network, such as backhaul, mobile core, IP core, and data center, working in harmony, the backhaul seems to have some of the highest complexity, due to the large set of multi-generation radios and transport realms. As such, it serves as a premium asset for operators to optimize to meet mass-market demand, and to make a quantum leap in reducing operating costs and remaining competitive.

## Mobile Backhaul Requirements

Clearly every operator has a unique set of existing network assets, and each operator has a unique timeline for preparing for and offering reliable, compelling mobile Internet services. That said, if we stick with the quantum network transformation as a common theme, the following may be used as one view of the major mobile backhaul requirements necessary to meet mobile Internet demand (Figure 2).

**Figure 2:** Major Requirements for Mobile Backhaul Networks

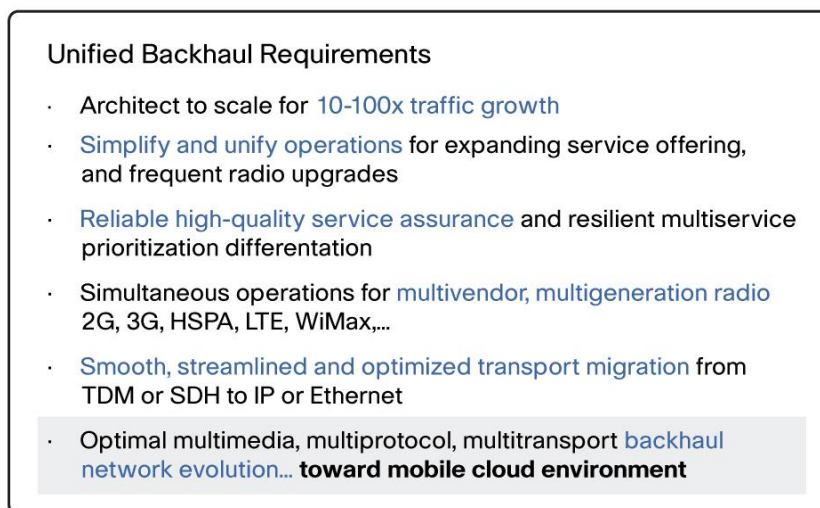

### Scale for 10 to 100x Traffic Growth

Due to the growth in mobile traffic, mobile operators have to design their networks based on an architecture that can scale to between 10 and 100 times the capacity of their existing networks. In addition, given the fact that most mobile networks are very large and span areas from urban high density to rural low density, most mobile operator networks need to simultaneously support backhaul segments that range from 1 Mbps capacity to 100 Mbps capacity or more at a cell site. And although there may be a quantum increase in demand for mass-scale mobile Internet and mobile broadband services, business realities dictate that the operator must be able to cover the costs of a major mobile backhaul transformation. As such, scaling the mobile backhaul network needs to be progressive and continuous, ideally in a pay-as-you-grow model, so that the network scales and grows commensurate with demand, thus optimizing the return on investment (ROI), rather than overbuilding the entire network prematurely.

Cisco and NEC offer a mobile backhaul migration strategy that lays the foundation for a 100-fold increase in traffic, but does so through a migration process that scales with demand, allowing operators to benefit from higher ROI in a pay-as-you-grow model.

## **Simplify and Unify Operations**

The mobile market requires fast service offerings and frequent radio upgrades. Because Radio Access Networks (RAN) have been around for quite some time, they already have a mixed array of radio and transport technologies, often from a mixed array of vendors. Now, with the advent of new Ethernet interfaces on the radios, and with the looming changes in radio control topologies from Code Division Multiple Access (CDMA) or Global System for Mobile Communications (GSM) to Long-Term Evolution (LTE), there is a real threat that managing the additional flexibility and complexity of a multi-generation network will result in more complex, error-prone, and costly network operations. As such, proactive steps need to be taken to keep ahead of and in control of operating costs. This requires a smooth migration for first interworking with existing operation, administration, and maintenance (OAM) systems while simultaneously overhauling the operating support systems (OSS), with the goal of simplifying and unifying the long-term operations of the backhaul network to assure that the reduced costs and improved capability due to the physical and architectural changes are managed harmoniously, with more robust and unified backhaul management systems and procedures.

Cisco and NEC offer a unified mobile backhaul network management suite that simultaneously integrates into key legacy OAM systems; has prebuilt, pre-integrated multivendor network device element management systems; and offers a new generation of zero-touch provisioning, service-level assurance management, and end-user service and subscription analytics to streamline and correlate the operations with the operator's real-time business objectives.

## **Reliable Service Assurance**

The mass market favors operators that deliver reliable, high-quality services. However, as a business, mobile operators need to offer multiple tiers of services to meet the multiple tiers of subscriber financial budgets: Nothing is free, and not everyone can afford to get everything they want. As such, it is absolutely critical for the operator network to work in harmony with the operator business objectives, and subscription contracts, to ensure that the highest quality of experience is offered and assured for those services that pay for a high quality of experience, such as a collaborative real-time business video conferencing solution, while assuring that services that are offered at a significant discount but do not have a strict service-level agreement (SLA), such as email downloads, do not in any way impede or interfere with the premium services, although all services are rendered simultaneously over the same network.

Efficient assurance and prioritization processes are mandatory within the backhaul network, and in conjunction with the mobile core and control systems, for delivering the appropriate and differentiated network resource priorities aligned to the business and SLA priorities.

For example, at times when there is network resource contention due to weather, network malfunction, or mass-market overload, the network resources need to be prioritized to assure that premium services are always delivered in accordance with the SLA, and that best-effort services do not push the network resources beyond stability.

Cisco and NEC offer a mobile backhaul solution that uses adaptive network resource utilization and hierarchical quality of service (QoS) assurances, tied together with network monitoring and assurance systems, that offer the necessary differentiation and assurance of multiservice subscriptions.

## **Flexible Multivendor RAN Simplification**

High investments (CapEx) are needed for the radio network upgrade. Vendors from around the world continue to compete in offering technological innovation and differentiation within their RAN products.

Because different vendors offer different value propositions at different stages of the evolution of mobile radio technology, it is common for an operator to have a mix of multivendor radio equipment within its network. It is important that the RAN backhaul network be built to service both the existing and forecast changes and additions of multivendor radio elements.

Moreover, given the nature of backhaul, these networks must evolve to manage architectural changes from CDMA and GSM to LTE, as well as opening additional operational advantages, such as macro cell offload via Wi-Fi or small cells, Internet offload of high-capacity best-effort traffic, and even opening access to new business options such as regional business services or optimal content and cloud service storage and offerings. To accommodate these changes, the backhaul network must support both multivendor and multigeneration radios and services.

### **Optimal Transport Migration**

Although the mobile Internet has mass-market appeal around the globe, the fact remains that today the vast majority of mobile network subscriptions, on a per-user basis, and the majority of aggregate revenue for a mobile operator's core business, are based on 2G mobile voice. Coverage and voice quality remain an absolutely critical component for every mobile operator, and as such, the baseline 2G voice services will remain in operation for several more years.

At issue is a technique for bringing 3G services, and mobile broadband services in particular, to subscribers who have the means to pay for the service. It can't happen for everyone everywhere - that is cost-prohibitive. As such, there is a requirement for offering a smooth transition and migration from existing 2G voice-centric transport mechanisms, such as TDM and SDH transport, to adaptive and cost-effective IP and Ethernet transport mechanisms. And since it is useless to enable 3G services and mobile broadband radio capability without a means to backhaul the higher traffic from the cell sites, it's important to establish a migration path in the backhaul architecture to be able to simultaneously support both legacy and new-generation radios and services.

Luckily, there are hybrid technologies, such as hybrid microwaves as well as hybrid pseudo-wire technology, that can be used to carry TDM traffic between legacy radios and legacy controllers over a more optimal packet-based infrastructure that is necessary as a new foundation for the mobile Internet. Similarly, it is important to be able to continue to offer reliable legacy services over legacy transport while next-generation transport is being deployed and brought into operation.

Some operators will choose to continue offering legacy services, such as 2G or 3G voice, over the preexisting legacy transport, building and dedicating a new-generation transport initially dedicated only to new, high-capacity mobile broadband services. But running dual networks has operational costs, and eventually most operators see the need to unify their backhaul networks.

Regardless of whether services are running across parallel transport networks or converged onto a common transport network, any updates to the backhaul network from the towers to the controllers and core must account for and ease the transition from, or simultaneously accommodate, existing and next-generation transport.

### **Optimal Multiservice Evolution**

The only constant is change (to paraphrase Heraclitus, 500 BC). What appears to be true in life is also true in mobile backhaul evolution. As previously mentioned, the RANs in particular have never remained constant, and as such the accompanying mobile backhaul networks have undergone change and must now go through further changes. This constant of change makes it useful to forecast and prepare for the likely changes that are ahead when laying the foundation for mobile backhaul today. One change is all but imminent for all operators, and three more likely evolutionary changes are worth taking note of.

The imminent change most likely to become universal for all operators is an evolution toward LTE. As has already been discussed, LTE is based upon IP, from the handset all the way to the mobile core. And LTE has a new architectural model involving several key new communication paths, particularly the X2 interface for cell-to-cell communication. Cisco has published a white paper that offers key insight into this issue: [Architectural Considerations for Backhaul of 2G/3G and LTE Networks](#).

As for the likely evolutionary changes, here are just three that are getting significant focus already.

First is the recent capability for seamless RAN macrocell offload, through techniques such as service provider Wi-Fi with HotSpot 2.0 or home and office extensions with femto or small cells. A unified RAN backhaul network could carry traffic from macro radios at cell sites over macro transport, as well as from hotspots and small cells over whatever transport is available there.

A second and as yet mostly untapped, undeployed option for mobile Internet optimization is the mobile cloud and mobile cloud services. The mobile cloud is a framework for reducing the distance and latency between a mobile service consumer and the mobile service content, such as watching a football game. The mobile cloud also serves as a technique for offering a “central” location for accessing key services, optimally “duplicating” them for access anywhere, with assurance of having a similar experience, such as business conferencing and collaboration services. A unified RAN backhaul solution deployed today would optimally have hooks within it to connect into critical components of the mobile cloud.

And finally, the world’s leading radio vendors have announced innovations made in micro-radios that will not use the traditional centralized radio controller model, but will rather distribute controllers and radios in a cloud RAN.

Each of these changes forecast on the horizon, together with the current changes required for multivendor, multitransport, multiprotocol mobile backhaul networks, all lead to a common conclusion: that an optimal mobile backhaul solution being deployed today should be able to withstand the inevitable evolutions forecast in the near future.

In general, the network architecture required for LTE and beyond is completely different from that of the 2G/3G era. A proper next-generation backhaul network is all IP based and summarized as a “simple” access network with “reliable and high-capacity” multiservice aggregation and end-to-end OAM. The Cisco and NEC joint solution aims to provide smooth evolution toward LTE and beyond.

### **3. Backhaul Network Transformation**

As we discussed earlier, to meet the quantum changes in mobile backhaul requirements described above, mobile operators need to review their network design and architectures, taking into consideration the following.

#### **Multilevel Convergence**

For the new backhaul networks, operators need to review the entire network protocol stack, from the physical layer to the protocols and even the service level, and build a solution that can converge all changes onto a common and unified backhaul solution.

#### **Transport Convergence**

Across the industry, analysts are citing input from operators and vendors that reveal a move to upgrade the primary physical layer transport used in mobile backhaul around the globe. At the macro market level, transport will evolve to being dominated by microwave and optical at Layers 0 and 1. The primary driver for this evolution is the demand for mobile Internet, and the spectral efficiency of LTE is driving up to and beyond 100 Mbps traffic from the cell site. Copper is losing traction in this market, while optical (fiber), especially in the metropolitan areas, and microwave are taking market share (Figure 3). Some markets, such as China, will be predominantly built on optical, given the mandate and backing from the central government. Other nations, such as India, will still have a majority of the backhaul network linked to microwave.

**Figure 3:** Trends in Copper, Optical, and Microwave Transport

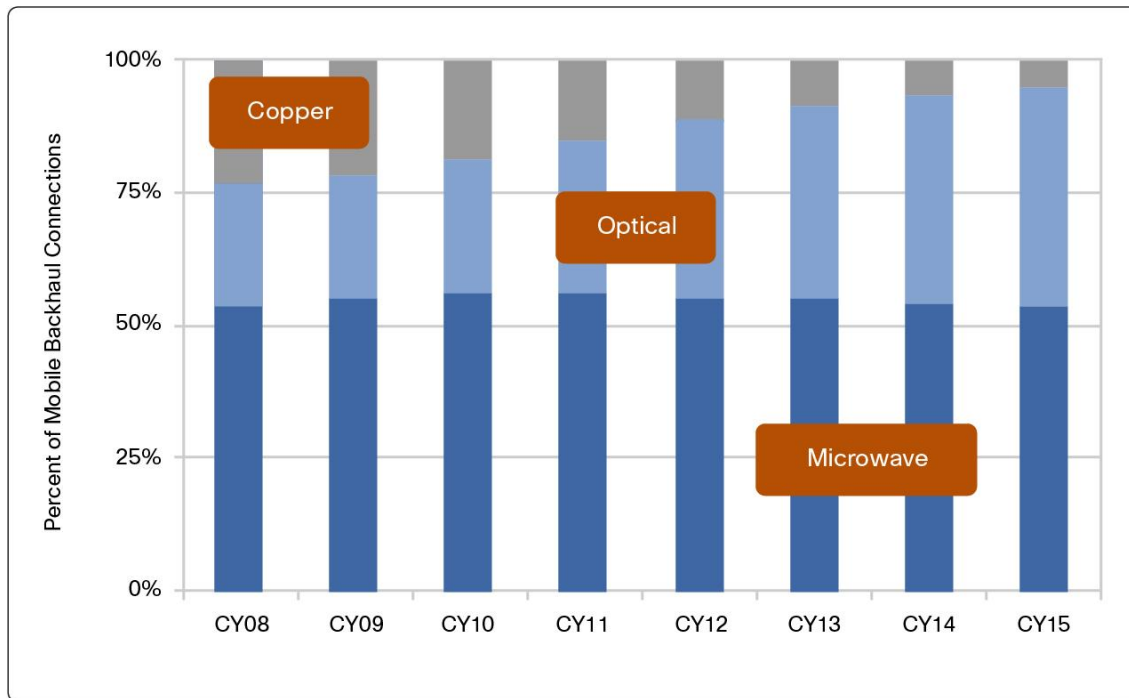

### Protocol Convergence

The legacy voice-centric mobile backhaul networks had one task - to carry mobile voice from the tower to the voice switching center and back again to the recipient tower. As such, all of the analog and TDM backhaul systems were ideally suited to offering efficient, reliable, and cost-effective point-to-point transport of circuit-oriented voice. But voice circuit transport is no longer the tall pole for backhaul. Mobile broadband services are already accounting for orders of magnitude more bandwidth than voice, and they dominate the requirements put on mobile backhaul. Also, due to the dynamic, multiservice demands of a mobile Internet and the statistical multiplexing gains that can be used for optimal multiservice aggregation, dedicated point-to-point circuits are overly restrictive and are nonoptimal in dealing with rapid change and real-time optimization.

The protocol of choice for mobile Internet is IP/MPLS and Ethernet at Layers 2 and 3. These have already been built into LTE at the standards level, and have been proven within the evolution of the fixed Internet, Layer 2 (switched or bridged) and Layer 3 (L3 routed) protocols can be positioned in different parts of the network. Usually the core and the aggregation networks are routed with Layer 3 using IP/MPLS. In some cases operators find advantages to extending Layer 3 to the cell site. In many cases, Layer 2 protocol is preferred in the access.

### Network Architecture Transformation

As previously discussed, networks must undergo an architectural transformation to meet the current and projected demands by mobile Internet. In particular, the metro and aggregation domain portions of the network are collapsing and expanding and are extending beyond the edge of the core and into the metro and RAN backhaul network (Figures 4 and 5).

**Figure 4:** Segmentation of Existing Mobile Transport Networks

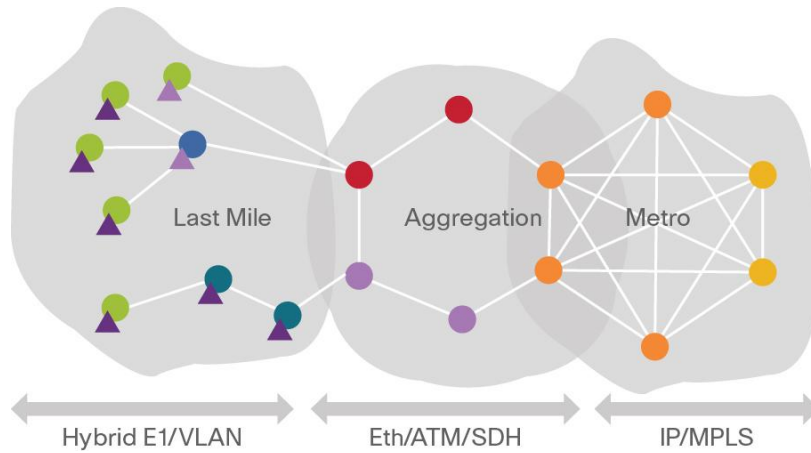

The existing mobile transport networks can be segmented into three areas:

- The metro or core network already running IP/MPLS
- The aggregation network that use SDH, Asynchronous Transfer Mode (ATM), and Ethernet protocols
- The access network (or last mile) that was traditionally based on E1/T1 or hybrid TDM/VLAN

**Figure 5:** Architectural Transformation

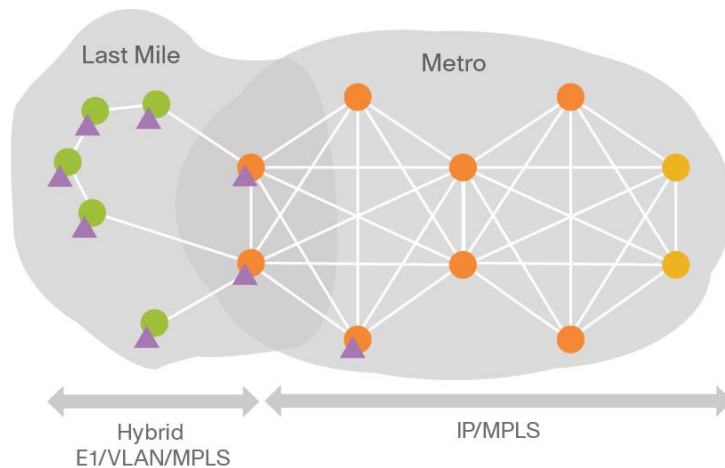

To cost-effectively meet the demands of mobile Internet, this traditional architecture needs to evolve and unify. Although a unified backhaul solution needs to provide a smooth migration from traditional to new-generation backhaul architecture, the architecture that serves as a more flexible and stable baseline for current and future mobile backhaul requirements should offer a more fully meshed metro and aggregation network and should use network access rings as much as possible, rather than the more restrictive and less optimal hub-and-spoke or tree architecture.

## Microwave Access Transformation

Worldwide, the radio microwave is the most utilized transport for the previous GSM technology and generally for 2G and 3G technologies in order to connect the cell site with the core network based on TDM/SDH technology.

The enhanced NodeB and LTE deployment is a compelling event not only for migrating the infrastructure from TDM/ATM to Ethernet/IP, but also for reviewing the access network topology.

The hub-and-spoke microwave topology can be turned into a ring topology, changing the 1+1 link protection into network-based protection (using 1+0 links) and improving the network's availability and resiliency while also producing savings in CapEx and OpEx.

**Figure 6:** Hub-and-Spoke and Ring Topologies

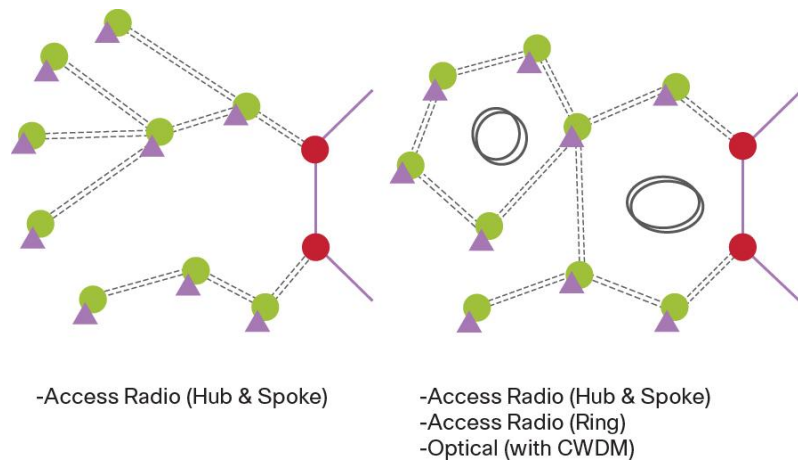

Advantages of microwave ring topology:

- Fewer microwave links: 1+1 is counted as two
- More optimal traffic throughput: Statistical multiplexing on ring
- Higher resiliency: Ring topology offers protection and path diversity
- High availability: Immunity from site and node failure
- Reuse of high frequencies: Only two links per node; single pair of frequencies per ring
- Lower power consumption and occupied footprint: Two-way radio(east/west) per hub

In addition to flexible management of the backhaul network topology migration, an “any media” solution manages capacity problems. By using optical media (fiber), it is possible to provide higher-capacity transport links; also, by using the coarse wavelength-division multiplexing (CWDM) feature, x-times capacity expansion is available with additional lambdas.

## Architectural Transformation Summary

To summarize, mobile networks are undergoing major transformation. Radios, transport, protocols, and architecture are all heading toward a pure packet, full IP transformation. The top of Figure 7 shows a composite of some of the GSMA radio network evolutions we've already discussed, from TDM to IP, starting with TDM for 2G, then ATM for GSM R99 and R4, to IP in an R5 to R7 data component for NodeB, and finally toward full IP for LTE (R8, R9) for enhanced NodeB.

**Figure 7:** Evolution from TDM to All IP in Mobile Networks

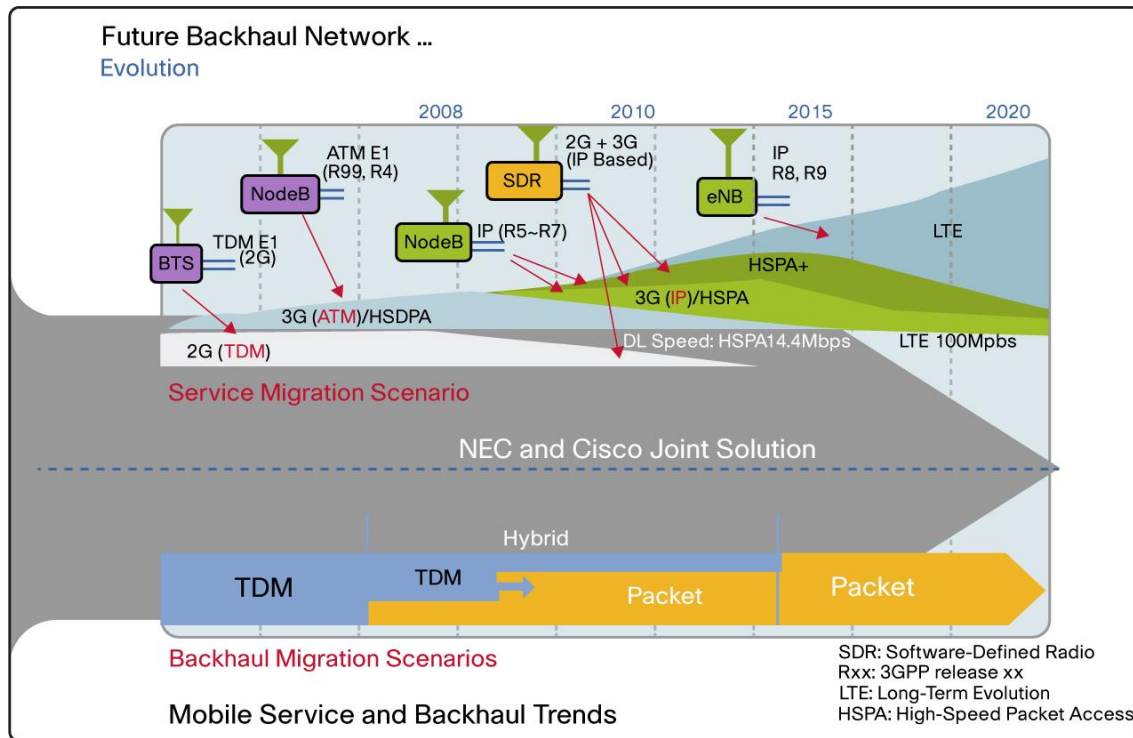

The lower portion of the figure depicts the backhaul migration scenarios that can be applied in moving from TDM through hybrid to all IP.

Having laid the groundwork for the broad market changes, we now focus on specific backhaul network technologies and solution components.

#### 4. Cisco and NEC: Unified Backhaul Expertise

NEC and Cisco have developed a memorandum of understanding to join forces in validating a joint mobile backhaul solution that integrates market-leading Cisco IP/MPLS platforms and NEC microwave/optical/packet converged transport platforms, and a combined unified mobile backhaul management suite. The primary reasons for this allegiance are to take advantage of the combined expertise of both companies in forming a single, validated solution. Before looking at the facets of the common and joint solution, we'll first summarize key leadership roles that Cisco and NEC bring to the mobile backhaul market (Figures 8 through 10).

**Figure 8:** NEC Transport Network Leadership

**NEC:**  
Optimized Microwave Backhaul Transport

- Number 1 market share microwave backhaul transport
- High reliability and resiliency
- Industry-leading best practices and accountability
- Market-leading backhaul and long-haul transport products
- In-house experts in microwave, optical, and switching technologies
- Consultation services, optimization tools, and collaborative expertise



Supplied Countries: 145 countries  
Number of TRs: 1,623K TRs

**Figure 9:** Cisco Unified RAN Backhaul Leadership

Cisco: Unified RAN Backhaul



**Scalability**

- Any radio, any media, many generations
- 100 times capacity; fraction of cost
- Flexible migration path



**IP Leadership**

- Extensive mobility experience-200+ customers in 75 countries
- Superior reliability and performance



**Comprehensive Solution**

- Unified, proactive management
- Full lifecycle services
- Mobile systems integration

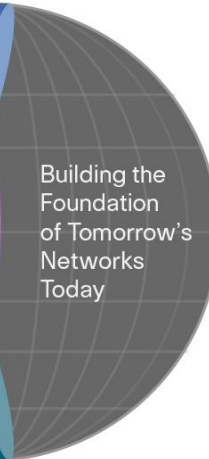

Building the  
Foundation  
of Tomorrow's  
Networks  
Today

**Figure 10:** Cisco and NEC Joint Mobile Backhaul Goals

NEC and Cisco:

Global Leader for Total Backhaul Solutions

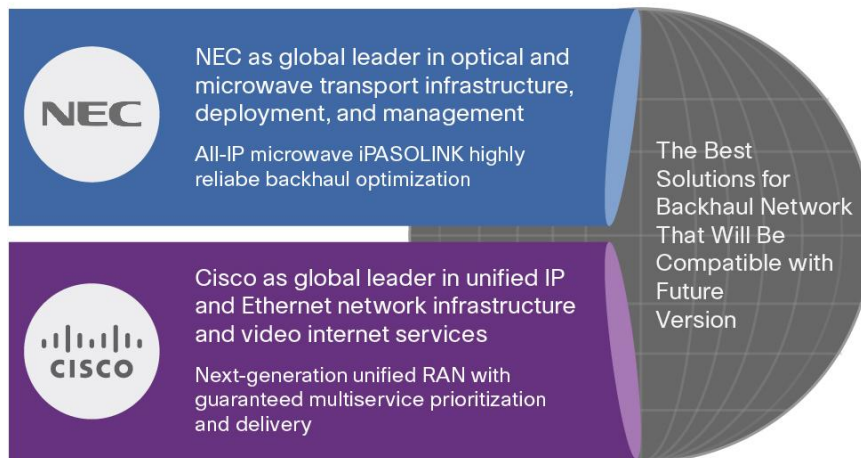

## Benefits of Cisco and NEC Joint Mobile Backhaul

The objectives of the Cisco and NEC alliance in the backhaul market are based on delivering the following (Figure 11):

- Availability: Real-traffic fast recovery and high quality of video delivery; high level of carrier-class network reliability and precision hybrid clock
- Adaptability: Transport any combination of any radio with any media
- Uniformity: Integrated management operation and optimal network transformation

Moreover, the joint solution is built to offer the combined ‘best-of-breed’ benefits from each company, with the following unique benefits:

- Industries lowest IP/Ethernet backhaul OPEX power consumption
- Industries highest Gbps capacity per Rack Unit (RU)
- Triple the Gbps/Watt backhaul capacity efficiency of competitive offers
- Multi-service (business, mobile, fixed) site efficiency
- The best transport for any Mobile and any Service
- Unified multi-vendor Network and Service Management
- Zero-touch auto-configuration of backhaul network devices
- Service assurance with automated correlation to avoid event storms
- Service discovery and service visualization
- Service and performance monitoring
- Industry leading hybrid-clock packet timing precision

**Figure 11: Benefits of the Joint Solution from Cisco and NEC**

NEC and Cisco:  
Joint Solution Benefits

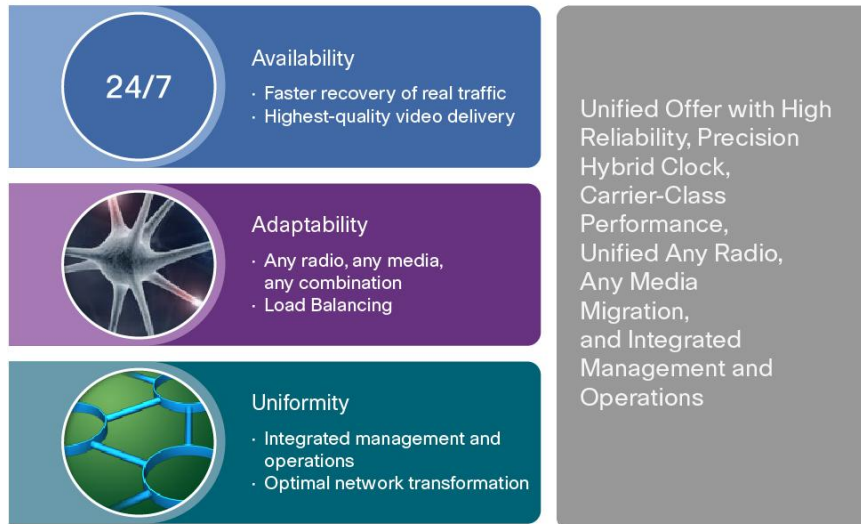

## NEC and Cisco Unified Backhaul Architecture

The NEC and Cisco joint backhaul system architecture strives to build out an aggregation network based on IP/MPLS protocols and, in most of the cases is based on Gigabit Ethernet or 10 Gigabit Ethernet, with redundant and meshed links connecting into the mobile core. As a multiservice aggregation resource, the aggregation network is built from routers and Microwave/Optical transport technologies that can simultaneously provide any mobile backhaul service, as well as offering peering points and extensions for IP/MPLS enterprise or business access services within the same geography. Moreover, the aggregation network is built with the capability to extend key points of presence POPs and aggregation nodes into entry points for mobile cloud content caching and service distribution.

This converged multiservice aggregation network can connect to any access network, such as legacy 2G circuit- or ring-based access networks, hybrid 2G and 3G access networks, and new pure LTE access network segments, as depicted in Figure 12. The diagram shows ring topologies, to emphasize the architectural advantages of moving toward ring and mesh architecture. However, the joint solution fully supports all other architectural formats and serves as a bridge in migrating from a traditional architecture to more optimal architectures.

**Figure 12: Converged Multiservice Aggregation Network**

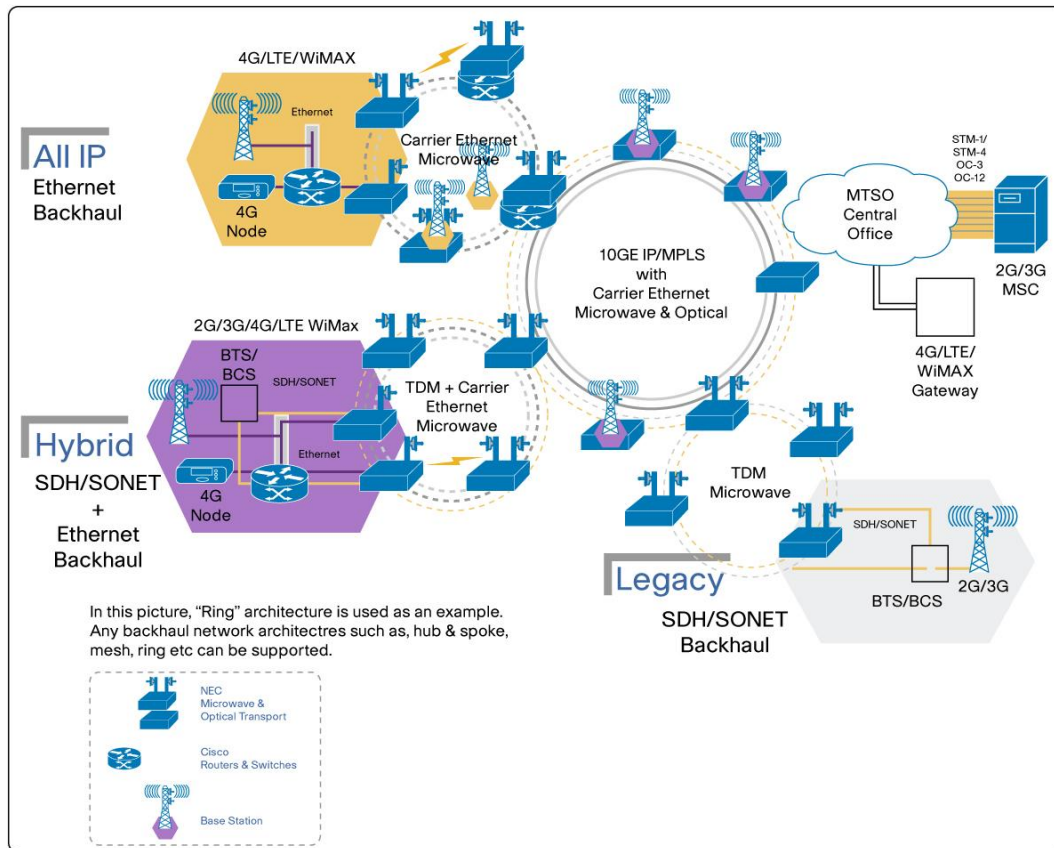

### Cisco Unified RAN and NEC Microwave Interoperability Testing

The NEC and Cisco backhaul system can deliver the best transport for any mobile network and any service, with proven end-to-end QoS, end-to-end operation and maintenance (O&M), and end-to-end Synchronous Ethernet (SyncE) and traffic engineering (Figure 13).

**Figure 13: Cisco and NEC Integrated Network Management**

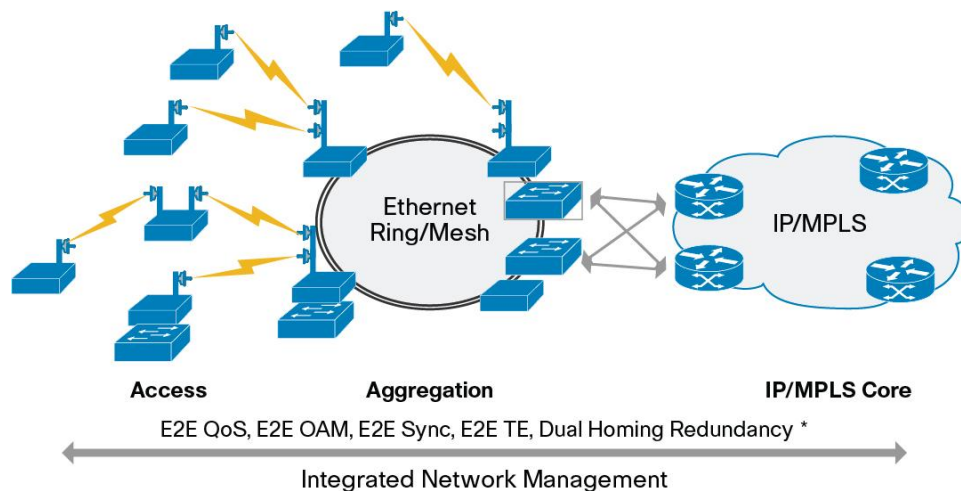

To ensure the reliability of the Cisco and NEC integrated solution, interoperability testing was performed, including:

- **End-to-end uniformity:** End to end uniformity is essential for Service Providers network operation. NEC and Cisco can provide best of breed devices within an end to end backhaul network, assuring uniformity and integrity of operations. For synchronization, several technologies, including SyncE and 1588v2, will be supported. An Ethernet OAM interwork based on IEEE 802.1ag is essential for carrier-grade end-to-end backhaul networking. These items have been tested and confirmed.
  - Synchronization test
  - Ethernet OAM test
  - **Integrated management (underway)**
- **High availability:** Higher availability is the most important part of the network especially with higher capacity transport. NEC 's microwave can provide a rich set of protection scenarios that flexibly fit any Service Providers' reliability requirements. Several protection schemes were tested to confirm the performance. Both the 1+1 linear and ring configurations were tested and were confirmed to provide carrier-grade performance, which is less than 50 ms protection time.
  - Protection test (1+1, L2 ring)
- **Adaptability:** Adaptability with any demand of traffic can be achieved with NEC's flexible transport technologies and Cisco's flexible adaptation and QoS technologies to provide a scalable and reliable network. High-capacity transport was tested with several configurations using radio links, and NEC's Adaptive Modulation Radio capability was confirmed with Cisco's packet priority assignments with QoS control.
  - High-capacity transport

### 1) Synchronous Ethernet Interoperability

- Fully verified SyncE interoperability by connecting a SyncE master device directly to a precise reference clock.
- Confirmed exchange of Synchronization Status Message (SSM) and correct distribution of clock quality-level information to adjacent nodes.
- Any synchronization through Ethernet will be available with this solution (Figure 14).

**Figure 14:** SyncE Interoperability Testing

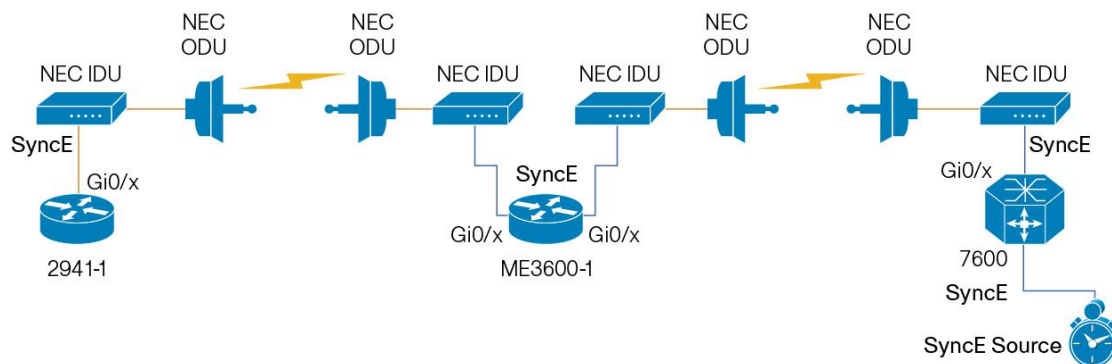

## 2) Ethernet OAM End-to-End Interoperability

- Fully verified end - to - end performance of Ethernet OAM features based on IEEE 802.1ag: connectivity fault management (CFM), continuity check (CC), loopback (LB), link trace (LT), etc. (Figure 15).

**Figure 15:** Ethernet OAM End-to-End Interoperability Testing

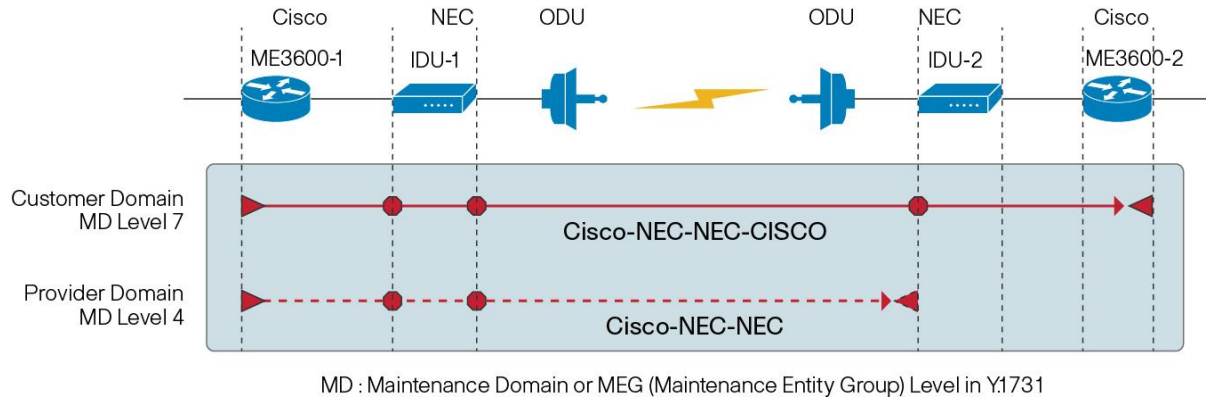

## 3) End-to-End Connection between VLAN Segment and MPLS Segment

**Figure 16:** Testing of End-to-End Connection

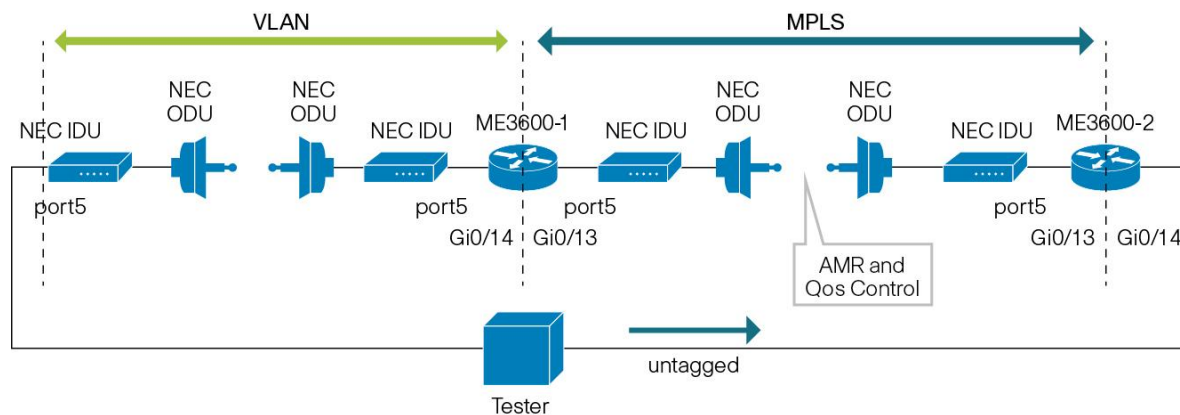

- Class of service (CoS) values of each VLAN were correctly mapped into EXP (Experimental) bit of MPLS.
- QoS controls were successfully applied during the change in radio bandwidth by adaptive modulation radio (AMR) (Figure 16).

## 4) Transport Protection for Higher Availability

- Proven robust Ethernet ring protection with Cisco Resilient Ethernet Protocol (REP).
- Fully functioning traffic load balancing achieved during ring switching with VLAN blocking control.
- Dual homing capability achieved with interworking of Virtual Router Redundancy Protocol (VRRP) with Ethernet ring (Figure 17).

**Figure 17: Testing of Transport Protection**

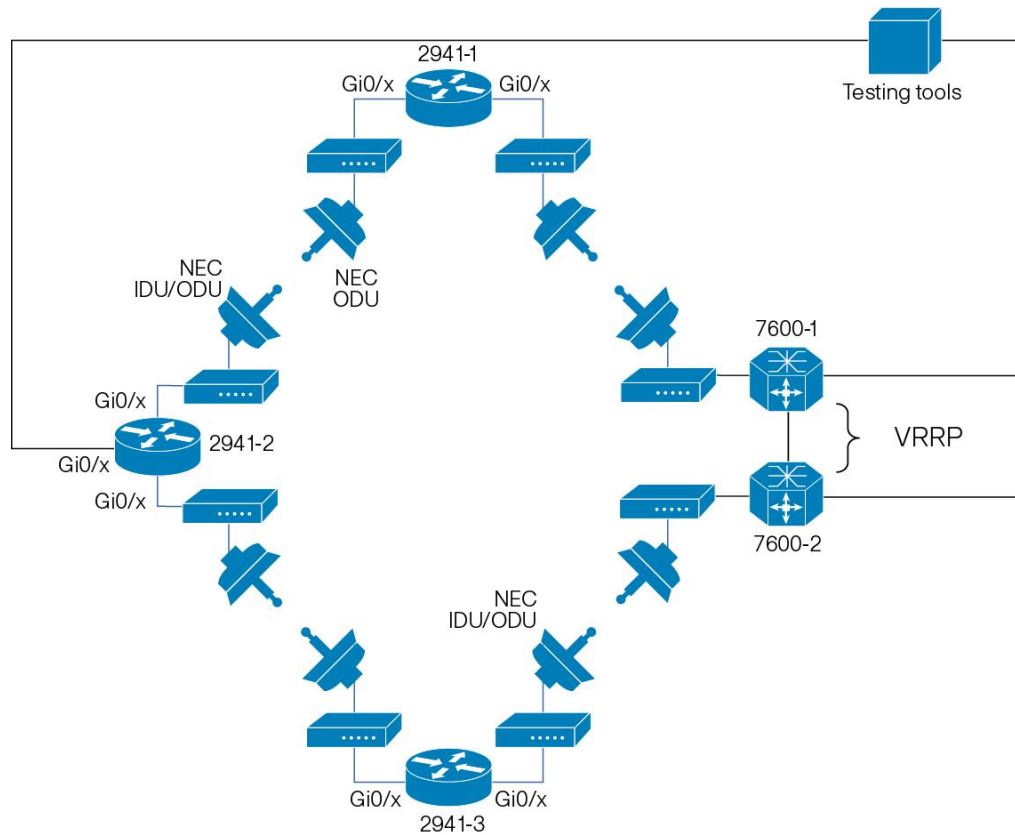

- Single points of failure are eliminated for resilient delivery of high-bandwidth services backed by carrier-class protection switching.

### 5) High-Capacity Radio with Bandwidth Management

- Confirmed the interwork between radio and routers with strong microwave features of iPASOLINK, such as a high-capacity link.
- Delivered 800 Mbps high-capacity throughput over the microwave link.
- Proven load balancing over the microwave link.
- Successful VLAN separation mapped into the specific microwave path using REP.

**Figure 18: Testing of High-Capacity Radio**

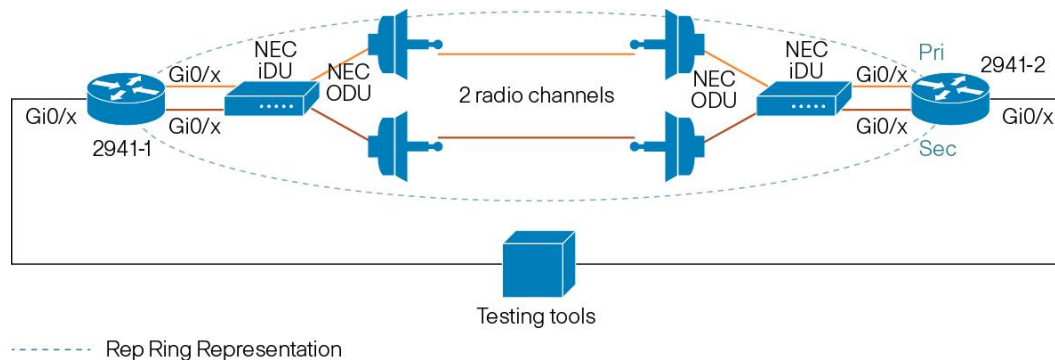

## 6) Network Management System Component

Cisco's PRIME network management for mobile backhaul, and NEC's MS5000 transport management system offer a full array of FCAPS, NMS, and Service Management capabilities, including:

- Friendly user interface to help the operator to accomplish common tasks
- Ability to provide fast time to value for new hardware investments
- Troubleshooting tools to easy locate and fix network outages
- Tools to proactively identify and correct points of failure in the network
- Run-time system to monitor network health
- Reduction and correlation of network events in a consolidated view

To further enhance the ease of use from the combined NMS systems, NEC and Cisco are further exploring joint NMS integration for optimal service management. At the time of writing the system integration characteristics were still being developed.

## Summary

NEC and Cisco are respective innovation and market share leaders in microwave, optical, and packet networking. We have joined forces to create and deliver a best-in-class end-to-end mobile backhaul solution, proven by successful interoperability tests. The joint solution addresses customer needs in backhaul network transformation and delivers high performance and cost efficiencies.

© 2012 Cisco / NEC Corporation.

Cisco and the Cisco Logo are trademarks of Cisco Systems, Inc. and/or affiliates in the U.S. and other countries. A listing of Cisco's trademarks can be found at [www.cisco.com/go/trademarks](http://www.cisco.com/go/trademarks). Third party trademarks mentioned are the property of their respective owners. The use of the word partner does not imply a partnership relationship between Cisco and any other company (1005R).

NEC is a registered trademark of NEC Corporation. All Rights Reserved. Other product or service marks mentioned herein are the trademarks of their respective owners.

C11-687693-00 01/12