



CHAPTER 24

Configuring Optional STP Features

This chapter describes how to configure optional STP features.



Note

For complete syntax and usage information for the commands used in this chapter, see the Cisco IOS Master Command List, Release 12.2SX, at this URL:

http://www.cisco.com/en/US/docs/ios/mcl/122sxmcl/12_2sx_mcl_book.html



Tip

For additional information about Cisco Catalyst 6500 Series Switches (including configuration examples and troubleshooting information), see the documents listed on this page:

http://www.cisco.com/en/US/products/hw/switches/ps708/tsd_products_support_series_home.html

This chapter consists of these sections:

- [Understanding the Optional STP Features, page 24-1](#)
- [Configuring the Optional STP Features, page 24-12](#)
- [Verifying the Optional STP Features, page 24-22](#)



Note

For information on configuring the Spanning Tree Protocol (STP), see [Chapter 23, “Configuring STP and MST.”](#)

Understanding the Optional STP Features

The optional features of the Spanning Tree Protocol (STP) enhance loop prevention, protect against some possible user misconfigurations, and provide better control over the protocol parameters. Although similar functionality may be incorporated into the IEEE 802.1w Rapid Spanning Tree Protocol (RSTP) standard, we recommend using these extensions. With the exception of PVST Simulation, all of these extensions can be used with both Rapid PVST+ and MST. PVST Simulation operates only with MST.

These sections describe the optional features:

- [Understanding STP Port Types, page 24-2](#)
- [Understanding PortFast, page 24-2](#)

- [Understanding Bridge Assurance, page 24-3](#)
- [Understanding BPDU Guard, page 24-5](#)
- [Understanding PortFast BPDU Filtering, page 24-5](#)
- [Understanding UplinkFast, page 24-6](#)
- [Understanding BackboneFast, page 24-7](#)
- [Understanding EtherChannel Guard, page 24-9](#)
- [Understanding Root Guard, page 24-10](#)
- [Understanding Loop Guard, page 24-10](#)
- [Understanding PVST Simulation, page 24-11](#)

Understanding STP Port Types

Beginning with Cisco IOS Release 12.2(33)SXI, you can specifically configure a spanning tree port as either an edge port, a network port, or a normal port. The port type determines the behavior of the port with respect to STP extensions.

An edge port, which is connected to a Layer 2 host, can be either an access port or a trunk port.

**Note**

If you configure a port connected to a Layer 2 switch or bridge as an edge port, you might create a bridging loop.

A network port is connected only to a Layer 2 switch or bridge.

**Note**

If you mistakenly configure a port that is connected to a Layer 2 host as a spanning tree network port, the port will automatically move into the blocking state.

The default spanning tree port type is normal, meaning only that its topology is not specified.

In releases earlier than Cisco IOS Release 12.2(33)SXI, configuring a port with PortFast implies that the port is an edge port; otherwise, the port is considered to be a normal port.

Understanding PortFast

STP PortFast causes a Layer 2 LAN port configured as an access port to enter the forwarding state immediately, bypassing the listening and learning states. You can use PortFast on Layer 2 access ports connected to a single workstation or server to allow those devices to connect to the network immediately, instead of waiting for STP to converge. Interfaces connected to a single workstation or server should not receive bridge protocol data units (BPDUs). When configured for PortFast, a port is still running the spanning tree protocol. A PortFast enabled port can immediately transition to the blocking state if necessary (this could happen on receipt of a superior BPDU). PortFast can be enabled on trunk ports. PortFast can have an operational value that is different from the configured value.

**Note**

Beginning with Cisco IOS Release 12.2(33)SXI, PortFast options are edge and normal. There is no difference between edge ports and PortFast ports.

**Caution**

Because the purpose of PortFast is to minimize the time that access ports must wait for STP to converge, it should only be used on access (edge) ports. If you enable PortFast on a port connected to a switch (a network port), you might create a temporary bridging loop.

Understanding Bridge Assurance

With Cisco IOS Release 12.2(33)SXJ and later releases, you can use Bridge Assurance to protect against certain problems that can cause bridging loops in the network. Specifically, you use Bridge Assurance to protect against a unidirectional link failure or other software failure and a device that continues to forward data traffic when it is no longer running the spanning tree algorithm.

**Note**

Bridge Assurance is supported only by Rapid PVST+ and MST.

Bridge Assurance is enabled by default and can only be disabled globally. Also, Bridge Assurance is enabled only on spanning tree network ports that are point-to-point links. Finally, both ends of the link must have Bridge Assurance enabled. If the device on one side of the link has Bridge Assurance enabled and the device on the other side either does not support Bridge Assurance or does not have this feature enabled, the connecting port is blocked.

With Bridge Assurance enabled, BPDUs are sent out on all operational network ports, including alternate and backup ports, for each hello time period. If the port does not receive a BPDU for a specified period, the port moves into an inconsistent state (blocking), and is not used in the root port calculation. Once that port receives a BPDU, it resumes the normal spanning tree transitions.

Figure 24-1 shows a normal STP topology, and Figure 24-2 demonstrates a potential network problem when the device fails and you are not running Bridge Assurance.

Figure 24-1 Network with Normal STP Topology

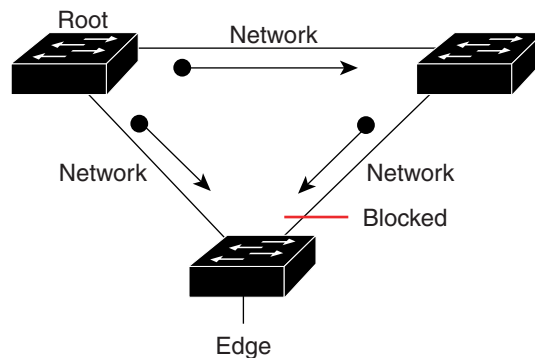
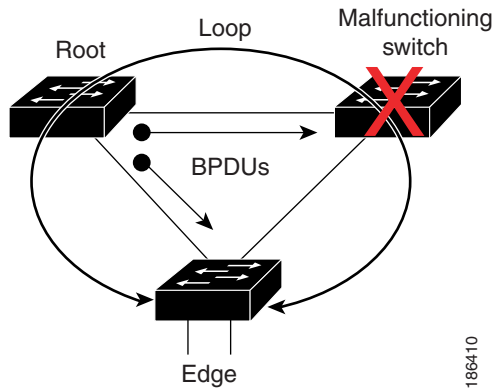

Figure 24-2 Network Problem without Running Bridge Assurance



186410

Figure 24-3 shows the network with Bridge Assurance enabled, and the STP topology progressing normally with bidirectional BPDUs issuing from every STP network port. Figure 24-4 shows how the potential network problem shown in Figure 24-2 does not happen when you have Bridge Assurance enabled on your network.

Figure 24-3 Network STP Topology Running Bridge Assurance

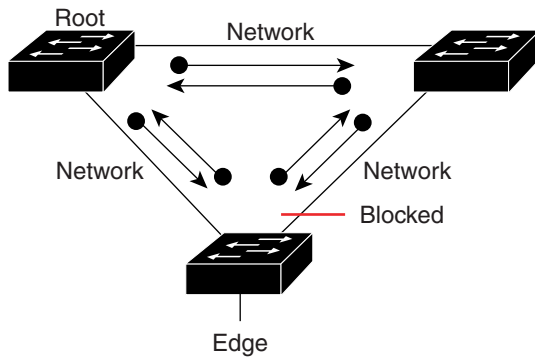

186526

Figure 24-4 Network Problem Averted with Bridge Assurance Enabled

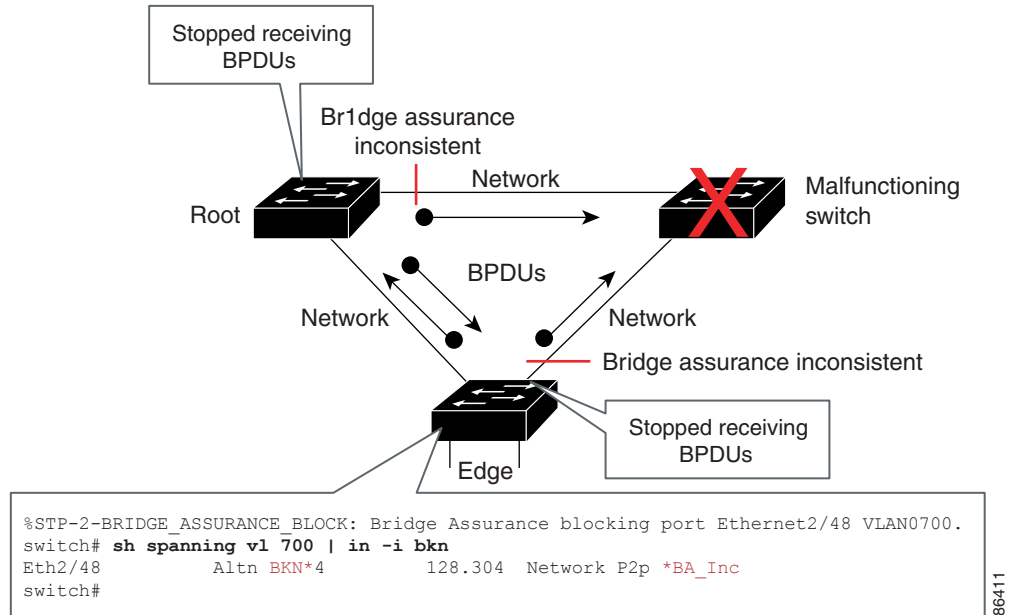

When using Bridge Assurance, follow these guidelines:

- Bridge Assurance runs only on point-to-point spanning tree network ports. You must configure each side of the link for this feature.
- We recommend that you enable Bridge Assurance throughout your network.

Understanding BPDU Guard

When enabled on a port, BPDU Guard shuts down a port that receives a BPDU. When configured globally, BPDU Guard is only effective on ports in the operational PortFast (edge) state. In a valid configuration, PortFast Layer 2 LAN interfaces (edge ports) do not receive BPDUs. Reception of a BPDU by a PortFast Layer 2 LAN interface signals an invalid configuration, such as connection of an unauthorized device. BPDU Guard provides a secure response to invalid configurations, because the administrator must manually put the Layer 2 LAN interface back in service. BPDU Guard can be configured at the interface level. When configured at the interface level, BPDU Guard shuts the port down as soon as the port receives a BPDU, regardless of the PortFast configuration.



Note

When enabled globally, BPDU Guard applies to all interfaces that are in an operational PortFast (edge) state.

Understanding PortFast BPDU Filtering

PortFast BPDU filtering allows the administrator to prevent the system from sending or even receiving BPDUs on specified ports.

**Note**

Beginning with Cisco IOS Release 12.2(33)SXI, PortFast BPDU Filtering is known as PortFast Edge BPDU Filtering.

When configured globally, PortFast BPDU filtering applies to all operational PortFast (edge) ports. Ports in an operational PortFast state are supposed to be connected to hosts, which typically drop BPDUs. If an operational PortFast port receives a BPDU, it immediately loses its operational PortFast status and becomes a normal port. In that case, PortFast BPDU filtering is disabled on this port and STP resumes sending BPDUs on this port.

PortFast BPDU filtering can also be configured on a per-port basis. When PortFast BPDU filtering is explicitly configured on a port, it does not send any BPDUs and drops all BPDUs it receives.

**Caution**

Explicitly configuring PortFast BPDU filtering on a port that is not connected to a host can result in bridging loops, as the port will ignore any BPDU it receives and will go to a forwarding state.

When you enable PortFast BPDU filtering globally and set the port configuration as the default for PortFast BPDU filtering (see the [“Enabling PortFast BPDU Filtering”](#) section on page 24-15), then PortFast enables or disables PortFast BPDU filtering.

If the port configuration is not set to default, then the PortFast configuration will not affect PortFast BPDU filtering. [Table 24-1](#) lists all the possible PortFast BPDU filtering combinations. PortFast BPDU filtering allows access ports to move directly to the forwarding state as soon as the end hosts are connected.

Table 24-1 PortFast BPDU Filtering Port Configurations

Per-Port Configuration	Global Configuration	PortFast State	PortFast BPDU Filtering State
Default	Enable	Enable	Enable ¹
Default	Enable	Disable	Disable
Default	Disable	Not applicable	Disable
Disable	Not applicable	Not applicable	Disable
Enable	Not applicable	Not applicable	Enable

1. The port transmits at least 10 BPDUs. If this port receives any BPDUs, then PortFast and PortFast BPDU filtering are disabled.

Understanding UplinkFast

UplinkFast provides fast convergence after a direct link failure and achieves load balancing between redundant Layer 2 links using uplink groups. An uplink group is a set of Layer 2 LAN interfaces (per VLAN), only one of which is forwarding at any given time. Specifically, an uplink group consists of the root port (which is forwarding) and a set of blocked ports, except for self-looping ports. The uplink group provides an alternate path in case the currently forwarding link fails.

**Note**

UplinkFast is most useful in wiring-closet switches. This feature may not be useful for other types of applications.

Figure 24-5 shows an example topology with no link failures. Switch A, the root bridge, is connected directly to Switch B over link L1 and to Switch C over link L2. The Layer 2 LAN interface on Switch C that is connected directly to Switch B is in the blocking state.

Figure 24-5 UplinkFast Example Before Direct Link Failure

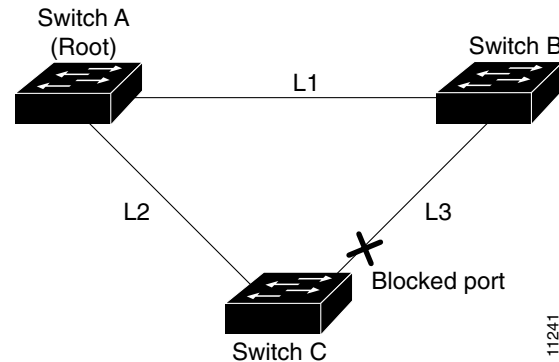

If Switch C detects a link failure on the currently active link L2 on the root port (a *direct* link failure), UplinkFast unblocks the blocked port on Switch C and transitions it to the forwarding state without going through the listening and learning states, as shown in Figure 24-6. This switchover takes approximately one to five seconds.

Figure 24-6 UplinkFast Example After Direct Link Failure

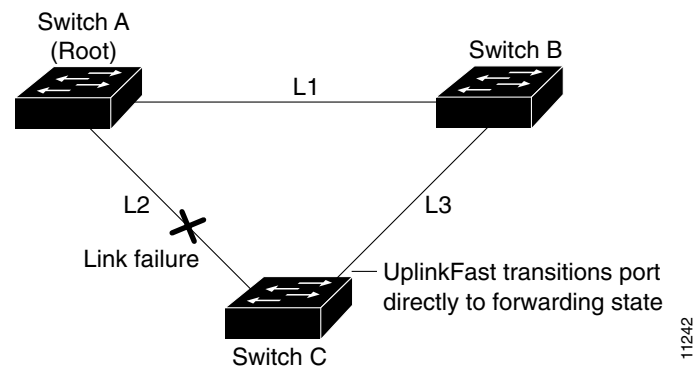

Understanding BackboneFast

BackboneFast is initiated when a root port or blocked port on a network device receives inferior BPDUs from its designated bridge. An inferior BPDU identifies one network device as both the root bridge and the designated bridge. When a network device receives an inferior BPDU, it indicates that a link to which the network device is not directly connected (an *indirect* link) has failed (that is, the designated bridge has lost its connection to the root bridge). Under normal STP rules, the network device ignores inferior BPDUs for the configured maximum aging time, as specified by the STP **max-age** command.

The network device tries to determine if it has an alternate path to the root bridge. If the inferior BPDU arrives on a blocked port, the root port and other blocked ports on the network device become alternate paths to the root bridge. (Self-looped ports are not considered alternate paths to the root bridge.) If the inferior BPDU arrives on the root port, all blocked ports become alternate paths to the root bridge. If the

inferior BPDU arrives on the root port and there are no blocked ports, the network device assumes that it has lost connectivity to the root bridge, causes the maximum aging time on the root to expire, and becomes the root bridge according to normal STP rules.

If the network device has alternate paths to the root bridge, it uses these alternate paths to transmit a new kind of Protocol Data Unit (PDU) called the Root Link Query PDU. The network device sends the Root Link Query PDU out all alternate paths to the root bridge. If the network device determines that it still has an alternate path to the root, it causes the maximum aging time to expire on the ports on which it received the inferior BPDU. If all the alternate paths to the root bridge indicate that the network device has lost connectivity to the root bridge, the network device causes the maximum aging times on the ports on which it received an inferior BPDU to expire. If one or more alternate paths can still connect to the root bridge, the network device makes all ports on which it received an inferior BPDU its designated ports and moves them out of the blocking state (if they were in the blocking state), through the listening and learning states, and into the forwarding state.

Figure 24-7 shows an example topology with no link failures. Switch A, the root bridge, connects directly to Switch B over link L1 and to Switch C over link L2. The Layer 2 LAN interface on Switch C that connects directly to Switch B is in the blocking state.

Figure 24-7 BackboneFast Example Before Indirect Link Failure

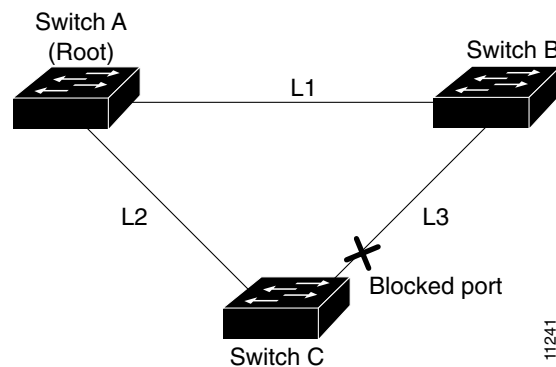

If link L1 fails, Switch C cannot detect this failure because it is not connected directly to link L1. However, because Switch B is directly connected to the root bridge over L1, it detects the failure and elects itself the root and begins sending BPDUs to Switch C indicating itself as the root. When Switch C receives the inferior BPDUs from Switch B, Switch C infers that an indirect failure has occurred. At that point, BackboneFast allows the blocked port on Switch C to move immediately to the listening state without waiting for the maximum aging time for the port to expire. BackboneFast then transitions the Layer 2 LAN interface on Switch C to the forwarding state, providing a path from Switch B to Switch A. This switchover takes approximately 30 seconds, twice the Forward Delay time if the default Forward Delay time of 15 seconds is set. Figure 24-8 shows how BackboneFast reconfigures the topology to account for the failure of link L1.

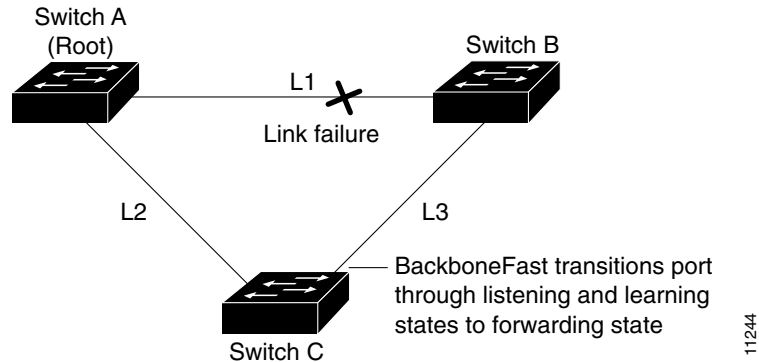
Figure 24-8 BackboneFast Example After Indirect Link Failure

If a new network device is introduced into a shared-medium topology as shown in [Figure 24-9](#), BackboneFast is not activated because the inferior BPDUs did not come from the recognized designated bridge (Switch B). The new network device begins sending inferior BPDUs that indicate that it is the root bridge. However, the other network devices ignore these inferior BPDUs and the new network device learns that Switch B is the designated bridge to Switch A, the root bridge.

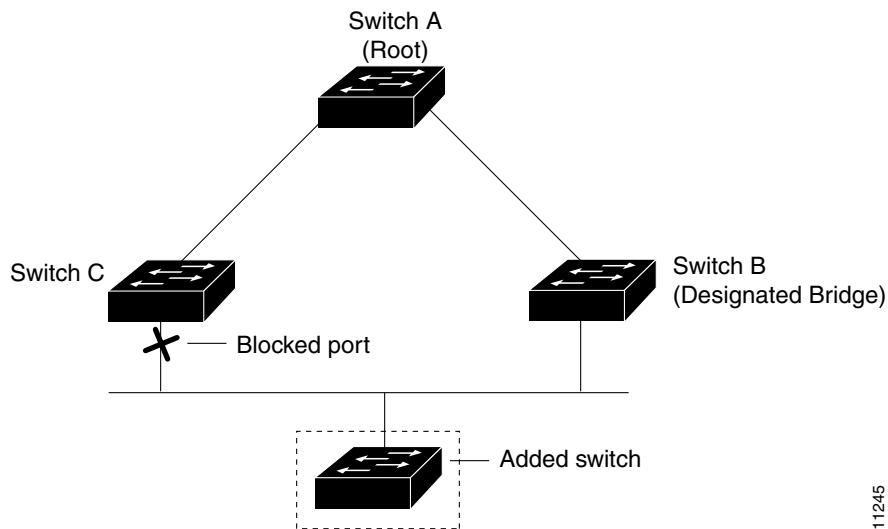
Figure 24-9 Adding a Network Device in a Shared-Medium Topology

Understanding EtherChannel Guard

EtherChannel guard detects a misconfigured EtherChannel when interfaces on the switch are configured as an EtherChannel while interfaces on the other device are not or when not all the interfaces on the other device are in the same EtherChannel.

In response to misconfiguration detected on the other device, EtherChannel guard puts interfaces on the switch into the errdisabled state.

Understanding Root Guard

The STP root guard feature prevents a port from becoming root port or blocked port. If a port configured for root guard receives a superior BPDU, the port immediately goes to the root-inconsistent (blocked) state.

Understanding Loop Guard

Loop guard helps prevent bridging loops that could occur because of a unidirectional link failure on a point-to-point link. When enabled globally, the loop guard applies to all point-to-point ports on the system. Loop guard detects root ports and blocked ports and ensures that they keep receiving BPDUs from their designated port on the segment. If a loop guard enabled root or blocked port stop a receiving BPDUs from its designated port, it transitions to the loop-inconsistent blocking state, assuming there is a physical link error on this port. The port recovers from this loop-inconsistent state as soon as it receives a BPDU.

You can enable loop guard on a per-port basis. When you enable loop guard, it is automatically applied to all of the active instances or VLANs to which that port belongs. When you disable loop guard, it is disabled for the specified ports. Disabling loop guard moves all loop-inconsistent ports to the listening state.

If you enable loop guard on a channel and the first link becomes unidirectional, loop guard blocks the entire channel until the affected port is removed from the channel. [Figure 24-10](#) shows loop guard in a triangle switch configuration.

Figure 24-10 Triangle Switch Configuration with Loop Guard

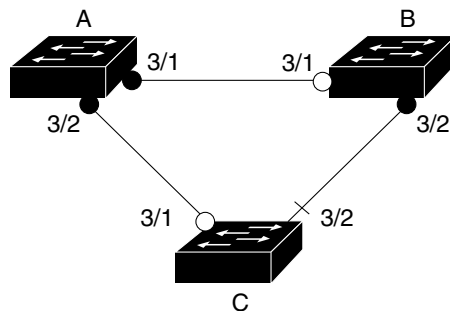

- Designated port
- Root port
- + Alternate port

55772

[Figure 24-10](#) illustrates the following configuration:

- Switches A and B are distribution switches.
- Switch C is an access switch.
- Loop guard is enabled on ports 3/1 and 3/2 on Switches A, B, and C.

Enabling loop guard on a root switch has no effect but provides protection when a root switch becomes a nonroot switch.

When using loop guard, follow these guidelines:

- You cannot enable loop guard on PortFast-enabled ports.
- You cannot enable loop guard if root guard is enabled.

Loop guard interacts with other features as follows:

- Loop guard does not affect the functionality of UplinkFast or BackboneFast.
- Enabling loop guard on ports that are not connected to a point-to-point link will not work.
- Root guard forces a port to be always designated as the root port. Loop guard is effective only if the port is a root port or an alternate port. You cannot enable loop guard and root guard on a port at the same time.
- Loop guard uses the ports known to spanning tree. Loop guard can take advantage of logical ports provided by the Port Aggregation Protocol (PAgP). However, to form a channel, all the physical ports grouped in the channel must have compatible configurations. PAgP enforces uniform configurations of root guard or loop guard on all the physical ports to form a channel.

These caveats apply to loop guard:

- Spanning tree always chooses the first operational port in the channel to send the BPDUs. If that link becomes unidirectional, loop guard blocks the channel, even if other links in the channel are functioning properly.
- If a set of ports that are already blocked by loop guard are grouped together to form a channel, spanning tree loses all the state information for those ports and the new channel port may obtain the forwarding state with a designated role.
- If a channel is blocked by loop guard and the channel breaks, spanning tree loses all the state information. The individual physical ports may obtain the forwarding state with the designated role, even if one or more of the links that formed the channel are unidirectional.

**Note**

You can enable UniDirectional Link Detection (UDLD) to help isolate the link failure. A loop may occur until UDLD detects the failure, but loop guard will not be able to detect it.

- Loop guard has no effect on a disabled spanning tree instance or a VLAN.

Understanding PVST Simulation

MST interoperates with Rapid PVST+ with no need for user configuration. The PVST simulation feature enables this seamless interoperability.

**Note**

PVST simulation is enabled by default when you enable MST. That is, by default, all interfaces on the device interoperate between MST and Rapid PVST+. The ability to disable PVST simulation is introduced in Cisco IOS Release 12.2(33)SXI.

You may want to control the connection between MST and Rapid PVST+ to protect against accidentally connecting an MST-enabled port to a port enabled to run Rapid PVST+. Because Rapid PVST+ is the default STP mode, you may encounter many Rapid PVST+ connections.

Disabling Rapid PVST+ simulation, which can be done per port or globally for the entire device, moves the MST-enabled port to the PVST peer inconsistent (blocking) state once it detects it is connected to a Rapid PVST+-enabled port. This port remains in the inconsistent state until the port stops receiving Shared Spanning Tree Protocol (SSTP) BPDUs, and then the port resumes the normal STP transition process.

The root bridge for all STP instances must all be in either the MST region or the Rapid PVST+ side. If the root bridge for all STP instances are not on one side or the other, the software moves the port into a PVST simulation-inconsistent state.

**Note**

We recommend that you put the root bridge for all STP instances in the MST region.

Configuring the Optional STP Features

This section includes the following topics:

- [Enabling PortFast, page 24-12](#)
- [Enabling Bridge Assurance, page 24-14](#)
- [Enabling PortFast BPDUs Filtering, page 24-15](#)
- [Enabling BPDUs Guard, page 24-16](#)
- [Enabling UplinkFast, page 24-17](#)
- [Enabling BackboneFast, page 24-18](#)
- [Enabling EtherChannel Guard, page 24-19](#)
- [Enabling Root Guard, page 24-19](#)
- [Enabling Loop Guard, page 24-20](#)
- [Configuring PVST Simulation, page 24-21](#)

Enabling PortFast

**Caution**

Use the PortFast feature only when connecting a single end station to a Layer 2 port. Otherwise, you might create a network loop.

Enabling PortFast on a Layer 2 Port

To enable PortFast on a Layer 2 port, perform this task:

	Command	Purpose
Step 1	Router(config)# interface {type ¹ slot/port} {port-channel port_channel_number}	Selects a port to configure.

	Command	Purpose
Step 2	Router(config-if)# no spanning-tree portfast	Configures the port as a normal port.
	Cisco IOS Release 12.2(33)SX1 and later releases:	
	Router(config-if)# spanning-tree portfast edge [trunk]	Enables edge behavior on a Layer 2 access port connected to a single workstation or server. The trunk keyword enables edge behavior on a trunk port.
	Router(config-if)# spanning-tree portfast network	Configures the port as a network port. Bridge Assurance, if enabled globally, will be enabled on the port.
	Router(config-if)# spanning-tree portfast edge disable	Disables edge behavior on the port.
	Earlier releases:	
	Router(config-if)# spanning-tree portfast [trunk]	Enables PortFast on a Layer 2 access port connected to a single workstation or server.
	Router(config-if)# spanning-tree portfast disable	Disables edge behavior on the port. Port will behave as a normal port.
Step 3	Router(config-if)# end	Exits configuration mode.
Step 4	Router# show running interface {type ¹ slot/port} {port-channel port_channel_number}	Verifies the configuration.

1. *type* = fastethernet, gigabitethernet, or tengigabitethernet

This example shows how to enable and verify PortFast on Fast Ethernet interface 5/8 in Cisco IOS Release 12.2(33)SX1 and later releases:

```
Router# configure terminal
Router(config)# interface fastethernet 5/8
Router(config-if)# spanning-tree portfast edge
Router(config-if)# end
Router#
Router# show running-config interface fastethernet 5/8
Building configuration...

Current configuration:
!
interface FastEthernet5/8
 no ip address
 switchport
 switchport access vlan 200
 switchport mode access
 spanning-tree portfast edge
end
Router#
```

This example shows how to enable and verify PortFast on Fast Ethernet interface 5/8 in releases earlier than Cisco IOS Release 12.2(33)SX1:

```
Router# configure terminal
Router(config)# interface fastethernet 5/8
Router(config-if)# spanning-tree portfast
Router(config-if)# end
Router#
Router# show running-config interface fastethernet 5/8
Building configuration...

Current configuration:
!
interface FastEthernet5/8
 no ip address
```

```

switchport
switchport access vlan 200
switchport mode access
spanning-tree portfast
end
Router#

```

Configuring the PortFast Default State

To set and verify the default PortFast configuration, perform this task:

	Command	Purpose
Step 1	<p>Cisco IOS Release 12.2(33)SXI and later releases:</p> <pre>Router(config)# spanning-tree portfast [edge network normal] default</pre> <p>Earlier releases:</p> <pre>Router(config)# [no] spanning-tree portfast default</pre>	<p>Configures the default state for all switch access ports to be edge, network, or normal. Bridge Assurance will be enabled on all network access ports by default.</p> <p>Configures the default state for all switch access ports to be edge. Use the no prefix to configure the default state to be normal.</p>
Step 2	Router(config-if)# end	Exits configuration mode.
Step 3	Router# show spanning-tree summary totals	Verifies the global configuration.
Step 4	Router# show spanning-tree interface {type¹ slot/port} detail	Verifies the effect on a specific port.

1. *type* = fastethernet, gigabitethernet, or tengigabitethernet

This example shows how to configure the default switch access port state to be edge in Cisco IOS Release 12.2(33)SXI and later releases:

```

Router# configure terminal
Enter configuration commands, one per line. End with CNTL/Z.
Router(config)# spanning-tree portfast edge default
Router(config)# ^Z

```

This example shows how to configure the default switch access port state to be edge in releases earlier than Cisco IOS Release 12.2(33)SXI:

```

Router# configure terminal
Enter configuration commands, one per line. End with CNTL/Z.
Router(config)# spanning-tree portfast default
Router(config)# ^Z

```

Enabling Bridge Assurance

Release 12.2(33)SXI and later releases support Bridge Assurance. By default, Bridge Assurance is enabled on all network ports on the switch. Disabling Bridge Assurance causes all configured network ports to behave as normal spanning tree ports. To enable or disable Bridge Assurance globally, perform this task:

Command	Purpose
Router(config)# spanning-tree bridge assurance	Enables Bridge Assurance on all network ports on the switch.

This example shows how to enable PortFast Bridge Assurance on all network ports on the switch, and how to configure a network port:

```
Router(config)# spanning-tree bridge assurance
Router(config)# interface fastethernet 5/8
Router(config-if)# spanning-tree portfast network
Router(config-if)# ^Z
```

Enabling PortFast BPDU Filtering

These sections describe how to configure PortFast BPDU filtering.

Enabling PortFast BPDU Filtering Globally

To enable PortFast BPDU filtering globally, perform this task:

	Command	Purpose
Step 1	<p>Cisco IOS Release 12.2(33)SXH and later releases:</p> <pre>Router(config)# spanning-tree portfast edge bpdufilter default</pre> <p>Earlier releases:</p> <pre>Router(config)# spanning-tree portfast bpdufilter default</pre>	Enables BPDU filtering globally by default on all edge ports of the switch. Use the no prefix to disable BPDU filtering by default on all edge ports of the switch.
Step 2	Router(config)# end	Exits configuration mode.
Step 3	Router# show spanning-tree summary totals	Verifies the configuration.

BPDU filtering is set to default on each edge port. This example shows how to enable PortFast BPDU filtering on the port and verify the configuration in **PVST+** mode:

```
Router(config)# spanning-tree portfast edge bpdufilter default
Router(config)# ^Z
```

```
Router# show spanning-tree summary totals
```

```
Root bridge for: Bridge VLAN0025
EtherChannel misconfiguration guard is enabled
Extended system ID is enabled
PortFast Edge BPDU Guard Default is disabled
Portfast Edge BPDU Filter Default is enabled
Portfast Default is edge
Bridge Assurance is enabled
Loopguard is disabled
UplinkFast is disabled
BackboneFast is disabled
Pathcost method used is long
```

```
Name          Blocking Listening Learning Forwarding STP Active
-----
2 vlans       0          0          0          3          3
Router#
```

Enabling PortFast BPDU Filtering on a Nontrunking Port

To enable or disable PortFast BPDU filtering on a nontrunking port, perform this task:

	Command	Purpose
Step 1	Router(config)# interface {type ¹ slot/port}	Selects the interface to configure.
Step 2	Router(config-if)# spanning-tree bpdupfilter [enable disable]	Enables or disables BPDU filtering on the port.
Step 3	Router(config-if)# end	Exits configuration mode.
Step 4	Router# show spanning-tree interface {type slot/port}	Verifies the configuration.

1. *type* = fastethernet, gigabitethernet, or tengigabitethernet

This example shows how to enable PortFast BPDU filtering on a nontrunking port:

```
Router(config)# interface fastEthernet 4/4
Router(config-if)# spanning-tree bpdupfilter enable
Router(config-if)# ^Z

Router# show spanning-tree interface fastEthernet 4/4

Vlan          Role Sts Cost      Prio.Nbr Status
-----
VLAN0010      Desg FWD 1000     160.196  Edge P2p

Router# show spanning-tree interface fastEthernet 4/4 detail
Port 196 (FastEthernet4/4) of VLAN0010 is forwarding
  Port path cost 1000, Port priority 160, Port Identifier 160.196.
  Designated root has priority 32768, address 00d0.00b8.140a
  Designated bridge has priority 32768, address 00d0.00b8.140a
  Designated port id is 160.196, designated path cost 0
  Timers:message age 0, forward delay 0, hold 0
  Number of transitions to forwarding state:1
  The port is in the portfast mode by portfast trunk configuration
  Link type is point-to-point by default
  Bpdu filter is enabled
  BPDU:sent 0, received 0
Router#
```

Enabling BPDU Guard

To enable BPDU Guard globally, perform this task:

	Command	Purpose
Step 1	<p>Cisco IOS Release 12.2(33)SXJ and later releases:</p> <pre>Router(config)# spanning-tree portfast edge bpduguard default</pre> <p>Earlier releases:</p> <pre>Router(config)# spanning-tree portfast bpduguard default</pre>	Enables BPDU Guard globally by default on all edge ports of the switch. Use the no form of the command to disable BPDU Guard by default on all edge ports of the switch.

	Command	Purpose
Step 2	Router(config)# end	Exits configuration mode.
Step 3	Router# show spanning-tree summary totals	Verifies the configuration.

This example shows how to enable BPDU Guard:

```
Router# configure terminal
Router(config)# spanning-tree portfast edge bpduguard default
Router(config)# end
Router#
```

This example shows how to verify the configuration:

```
Router# show spanning-tree summary totals
Root bridge for: Bridge VLAN0025
EtherChannel misconfiguration guard is enabled
Extended system ID is enabled
PortFast Edge BPDU Guard Default is enabled
Portfast Edge BPDU Filter Default is disabled
Portfast Default is edge
Bridge Assurance is enabled
Loopguard is disabled
UplinkFast is disabled
BackboneFast is disabled
Pathcost method used is long

Name                               Blocking Listening Learning Forwarding STP Active
-----
2 vlans                             0           0           0           3           3
Router#
```

Enabling UplinkFast

UplinkFast increases the bridge priority to 49152 and adds 3000 to the STP port cost of all Layer 2 LAN ports on the switch, decreasing the probability that the switch will become the root bridge. UplinkFast cannot be enabled on VLANs that have been configured for bridge priority. To enable UplinkFast on a VLAN with bridge priority configured, restore the bridge priority on the VLAN to the default value by entering a **no spanning-tree vlan *vlan_ID* priority** command in global configuration mode.



Note

When you enable UplinkFast, it affects all VLANs on the switch. You cannot configure UplinkFast on an individual VLAN.

To enable UplinkFast, perform this task:

	Command	Purpose
Step 1	Router(config)# spanning-tree uplinkfast	Enables UplinkFast.
	Router(config)# spanning-tree uplinkfast [max-update-rate <i>max_update_rate</i>]	Enables UplinkFast with an update rate in seconds.
Step 2	Router(config)# end	Exits configuration mode.
Step 3	Router# show spanning-tree vlan <i>vlan_ID</i>	Verifies that UplinkFast is enabled.

This example shows how to enable UplinkFast:

```
Router# configure terminal
Router(config)# spanning-tree uplinkfast
Router(config)# exit
Router#
```

This example shows how to enable UplinkFast with an update rate of 400 packets per second:

```
Router# configure terminal
Router(config)# spanning-tree uplinkfast
Router(config)# spanning-tree uplinkfast max-update-rate 400
Router(config)# exit
Router#
```

This example shows how to verify that UplinkFast is enabled:

```
Router# show spanning-tree uplinkfast
UplinkFast is enabled
Router#
```

Enabling BackboneFast



Note

BackboneFast operates correctly only when enabled on all network devices in the network. BackboneFast is not supported on Token Ring VLANs. This feature is supported for use with third-party network devices.

To enable BackboneFast, perform this task:

	Command	Purpose
Step 1	Router(config)# spanning-tree backbonefast	Enables BackboneFast.
Step 2	Router(config)# end	Exits configuration mode.
Step 3	Router# show spanning-tree vlan <i>vlan_ID</i>	Verifies that BackboneFast is enabled.

This example shows how to enable BackboneFast:

```
Router# configure terminal
Router(config)# spanning-tree backbonefast
Router(config)# end
Router#
```

This example shows how to verify that BackboneFast is enabled:

```
Router# show spanning-tree backbonefast
BackboneFast is enabled

BackboneFast statistics
-----
Number of transition via backboneFast (all VLANs) : 0
Number of inferior BPDUs received (all VLANs)    : 0
Number of RLQ request PDUs received (all VLANs)  : 0
Number of RLQ response PDUs received (all VLANs) : 0
Number of RLQ request PDUs sent (all VLANs)     : 0
Number of RLQ response PDUs sent (all VLANs)    : 0
Router#
```

Enabling EtherChannel Guard

To enable EtherChannel guard, perform this task:

	Command	Purpose
Step 1	Router(config)# spanning-tree etherchannel guard misconfig	Enables EtherChannel guard.
Step 2	Router(config)# end	Exits configuration mode.
Step 3	Router# show spanning-tree summary include EtherChannel	Verifies that EtherChannel guard is enabled.

This example shows how to enable EtherChannel guard:

```
Router# configure terminal
Router(config)# spanning-tree etherchannel guard misconfig
Router(config)# end
Router#
```

This example shows how to verify the configuration:

```
Router# show spanning-tree summary | include EtherChannel
EtherChannel misconfiguration guard is enabled
```

To display the interfaces that are in the errdisable state, enter the **show interface status err-disable** command.

After the misconfiguration has been cleared, interfaces in the errdisable state might automatically recover. To manually return a port to service, enter a **shutdown** and then a **no shutdown** command for the interface.

Enabling Root Guard

To enable root guard, perform this task:

	Command	Purpose
Step 1	Router(config)# interface {type ¹ slot/port} {port-channel port_channel_number}	Selects a port to configure.
Step 2	Router(config-if)# spanning-tree guard root	Enables root guard.
Step 3	Router(config-if)# end	Exits configuration mode.
Step 4	Router# show spanning-tree Router# show running interface {type ¹ slot/port} {port-channel port_channel_number}	Verifies the configuration.

1. *type* = fastethernet, gigabitethernet, or tengigabitethernet

To display ports that are in the root-inconsistent state, enter the **show spanning-tree inconsistentports** command.

Enabling Loop Guard

To enable loop guard globally on the switch, perform this task:

	Command	Purpose
Step 1	Router(config)# spanning-tree loopguard default	Enables loop guard globally on the switch.
Step 2	Router(config)# end	Exits configuration mode.
Step 3	Router# show spanning-tree interface {type ¹ slot/port} detail	Verifies the configuration impact on a port.

1. *type* = fastethernet, gigabitethernet, or tengigabitethernet

This example shows how to enable loop guard globally:

```
Router# configure terminal
```

```
Enter configuration commands, one per line. End with CNTL/Z.
```

```
Router(config)# spanning-tree loopguard default
```

```
Router(config)# ^Z
```

```
Router# show spanning-tree interface fastEthernet 4/4 detail
```

```
Port 196 (FastEthernet4/4) of VLAN0010 is forwarding
  Port path cost 1000, Port priority 160, Port Identifier 160.196.
  Designated root has priority 32768, address 00d0.00b8.140a
  Designated bridge has priority 32768, address 00d0.00b8.140a
  Designated port id is 160.196, designated path cost 0
  Timers:message age 0, forward delay 0, hold 0
  Number of transitions to forwarding state:1
  The port is in the portfast mode by portfast trunk configuration
  Link type is point-to-point by default
  Bpdu filter is enabled
  Loop guard is enabled by default on the port
  BPDU:sent 0, received 0
```

To enable loop guard on a port, perform this task:

	Command	Purpose
Step 1	Router(config)# interface {type ¹ slot/port} {port-channel port_channel_number}	Selects a port to configure.
Step 2	Router(config-if)# spanning-tree guard loop	Configures loop guard.
Step 3	Router(config)# end	Exits configuration mode.
Step 4	Router# show spanning-tree interface {type slot/port} detail	Verifies the configuration impact on that port.

1. *type* = fastethernet, gigabitethernet, or tengigabitethernet

This example shows how to enable loop guard:

```
Router# configure terminal
```

```
Enter configuration commands, one per line. End with CNTL/Z.
```

```
Router(config)# interface fastEthernet 4/4
```

```
Router(config-if)# spanning-tree guard loop
```

```
Router(config-if)# ^Z
```

This example shows how to verify the configuration:

```
Router# show spanning-tree interface fastEthernet 4/4 detail
Port 196 (FastEthernet4/4) of VLAN0010 is forwarding
  Port path cost 1000, Port priority 160, Port Identifier 160.196.
  Designated root has priority 32768, address 00d0.00b8.140a
  Designated bridge has priority 32768, address 00d0.00b8.140a
  Designated port id is 160.196, designated path cost 0
  Timers:message age 0, forward delay 0, hold 0
  Number of transitions to forwarding state:1
  The port is in the portfast mode by portfast trunk configuration
  Link type is point-to-point by default
  Bpdu filter is enabled
  Loop guard is enabled on the port
  BPDU:sent 0, received 0
Router#
```

Configuring PVST Simulation



Note

PVST simulation is enabled by default so that all interfaces on the device interoperate between MST and Rapid PVST+. The ability to disable PVST simulation is introduced in Cisco IOS Release 12.2(33)SXI.

To prevent an accidental connection to a device that does not run MST as the default STP mode, you can disable PVST simulation. If you disable PVST simulation, the MST-enabled port moves to the blocking state once it detects it is connected to a Rapid PVST+-enabled port. This port remains in the inconsistent state until the port stops receiving BPDUs, and then the port resumes the normal STP transition process.

To enable or disable PVST simulation globally, enter the command using the **global** keyword, as shown in the following task:

Command	Purpose
Router(config)# spanning-tree mst simulate pvst global	Enables all ports to automatically interoperate with a connected device that is running in Rapid PVST+ mode. The default is enabled; all interfaces will operate seamlessly between Rapid PVST+ and MST.

To override the global PVST simulation setting for a port, enter the command in the interface command mode, as shown in the following task:

	Command	Purpose
Step 1	Router(config)# interface {type ¹ slot/port}	Selects a port to configure.
Step 2	Router(config-if)# spanning-tree mst simulate pvst	Enables this interface to automatically interoperate with a connected device that is running in Rapid PVST+ mode.

1. *type* = fastethernet, gigabitethernet, or tengigabitethernet

This example shows how to prevent the switch from automatically interoperating with a connecting device that is running Rapid PVST+:

```
Router(config)# no spanning-tree mst simulate pvst global
```

This example shows how to prevent a port from automatically interoperating with a connecting device that is running Rapid PVST+:

```
Router(config)# interface gi3/13
Router(config-if)# spanning-tree mst simulate pvst disable
```

Verifying the Optional STP Features

This section includes the following topics:

- [Using the show spanning-tree Commands, page 24-22](#)
- [Examples in Release 12.2\(33\)SXI and Later Releases, page 24-22](#)
- [Examples in Releases Earlier Than Release 12.2\(33\)SXI, page 24-25](#)

Using the show spanning-tree Commands

You can view spanning tree status and configuration information, both global and port-level, using the **show spanning-tree** commands described in this section.

To view spanning tree status and configuration information, perform one of the following tasks:

Command	Purpose
Router# show spanning-tree	Displays information about the spanning tree, including protocol type and port types.
Router# show spanning-tree summary	Displays a summary of the spanning tree feature settings and the spanning tree states of the VLANs.
Router# show spanning-tree summary totals	Displays a summary of the spanning tree feature settings and totals of the VLAN states.
Router# show spanning-tree interface {type ¹ slot/port} detail	Displays the spanning tree status details of an interface.
Router# show spanning-tree interface {type ¹ slot/port} portfast edge	Displays the spanning tree portfast edge interface operational state for all the instances. In releases earlier than Cisco IOS Release 12.2(33)SXI, the edge keyword is not used.

1. *type* = fastethernet, gigabitethernet, or tengigabitethernet

Examples in Release 12.2(33)SXI and Later Releases



Note

The output of the **show spanning-tree** commands in releases earlier than Release 12.2(33)SXI differs from the output in Release 12.2(33)SXI and later releases. The differences are shown in bold in the examples in this section.

This example displays the spanning-tree status with Bridge Assurance enabled but in the inconsistent state:

```

Router# show spanning-tree
VLAN0010
  Spanning tree enabled protocol rstp
  Root ID    Priority    32778
            Address     0002.172c.f400
            This bridge is the root
            Hello Time  2 sec  Max Age 20 sec  Forward Delay 15 sec

  Bridge ID  Priority    32778 (priority 32768 sys-id-ext 10)
            Address     0002.172c.f400
            Hello Time  2 sec  Max Age 20 sec  Forward Delay 15 sec
            Aging Time 300

Interface          Role Sts Cost          Prio.Nbr Type
-----
Gi3/14             Desg BKN*4          128.270 Network, P2p *BA_Inc
Router#

```

The following inconsistency messages can be appended to the Type field:

- *BA_Inc—Indicates that Bridge Assurance is in the inconsistent state.
- *PVST_Peer_Inc—Indicates that the port is in a peer type Inconsistent state.
- Dispute—Indicates that a dispute condition is detected.

This example shows the spanning-tree configuration summary:

```

Router# show spanning-tree summary

Switch is in rapid-pvst mode
Root bridge for: Bridge VLAN0025
EtherChannel misconfiguration guard is enabled
Extended system ID is enabled
PortFast Edge BPDU Guard Default is disabled
Portfast Edge BPDU Filter Default is disabled
Portfast Default is edge
Bridge Assurance is enabled
Loopguard is disabled
UplinkFast is disabled
BackboneFast is disabled
Pathcost method used is short
PVST Simulation Default is enabled

Name                Blocking Listening Learning Forwarding STP Active
-----
VLAN0025             0          0          0          1          1
VLAN0030             0          0          0          2          2
-----
2 vlans              0          0          0          3          3
Router#

```

Possible states for the Bridge Assurance field are as follows:

- is enabled
- is disabled
- is enabled but not active in the PVST mode

This example shows the spanning tree summary when PVST simulation is disabled in any STP mode:

```

Router# show spanning-tree summary

```

```
Switch is in mst mode (IEEE Standard)
Root bridge for: MST0
EtherChannel misconfig guard is enabled
Extended system ID          is enabled
Portfast Default            is disabled
PortFast BPDU Guard Default is disabled
Portfast BPDU Filter Default is disabled
Loopguard Default          is disabled
UplinkFast                  is disabled
BackboneFast                is disabled
Pathcost method used        is long
PVST Simulation Default    is disabled
```

Name	Blocking	Listening	Learning	Forwarding	STP Active
MST0	2	0	0	0	2
1 mst	2	0	0	0	2

Possible states for the PVST Simulation Default field are as follows:

- is enabled
- is disabled
- is enabled but not active in rapid-PVST mode

This example shows the spanning tree summary totals:

```
Router# show spanning-tree summary totals
Root bridge for: Bridge VLAN0025
EtherChannel misconfiguration guard is enabled
Extended system ID          is enabled
PortFast Edge BPDU Guard Default is enabled
Portfast Edge BPDU Filter Default is disabled
Portfast Default          is edge
Bridge Assurance         is enabled
Loopguard                   is disabled
UplinkFast                  is disabled
BackboneFast                is disabled
Pathcost method used is long
```

Name	Blocking	Listening	Learning	Forwarding	STP Active
2 vlans	0	0	0	3	3

This example shows the spanning-tree configuration details of an edge port:

```
Router# show spanning-tree interface gi3/13 detail
Port 269 (GigabitEthernet3/13) of VLAN0002 is forwarding
  Port path cost 4, Port priority 128, Port Identifier 128.269.
  Designated root has priority 32770, address 0002.172c.f400
  Designated bridge has priority 32770, address 0002.172c.f400
  Designated port id is 128.269, designated path cost 0
  Timers: message age 0, forward delay 0, hold 0
  Number of transitions to forwarding state: 1
  Link type is point-to-point by default
  Loop guard is enabled by default on the port
  The port is in the portfast edge mode by default
  BPDU: sent 2183, received 0
```

This example shows the spanning-tree configuration details of a trunk port:

```
Router(config-if)# spanning-tree portfast edge trunk
%Warning:portfast should only be enabled on ports connected to a single
```

host. Connecting hubs, concentrators, switches, bridges, etc... to this interface when portfast is enabled, can cause temporary bridging loops.
Use with CAUTION

```
Router(config-if)# ^Z
```

```
Router# show spanning-tree interface gi3/13 detail
Port 269 (GigabitEthernet3/13) of VLAN0002 is forwarding
  Port path cost 4, Port priority 128, Port Identifier 128.269.
  Designated root has priority 32770, address 0002.172c.f400
  Designated bridge has priority 32770, address 0002.172c.f400
  Designated port id is 128.269, designated path cost 0
  Timers: message age 0, forward delay 0, hold 0
  Number of transitions to forwarding state: 1
  Link type is point-to-point by default
  Loop guard is enabled by default on the port
  The port is in the portfast edge trunk mode
  BPDU: sent 2183, received 0
Router#
```

This example shows the spanning-tree configuration details of an edge port when a dispute condition has been detected:

```
Router# show spanning-tree interface gi3/13 detail
Port 269 (GigabitEthernet3/13) of VLAN0002 is designated blocking (dispute)
  Port path cost 4, Port priority 128, Port Identifier 128.297.
  Designated root has priority 32769, address 0013.5f20.01c0
  Designated bridge has priority 32769, address 0013.5f20.01c0
  Designated port id is 128.297, designated path cost 0
  Timers: message age 0, forward delay 0, hold 0
  Number of transitions to forwarding state: 1
  Link type is point-to-point by default
  BPDU: sent 132, received 1
Router#
```

This example shows the spanning tree portfast edge interface operational state for all the instances:

```
Router# show spanning-tree interface gi3/1 portfast edge
MST0          disabled
MST1          disabled
```

Examples in Releases Earlier Than Release 12.2(33)SXI



Note

The output of the **show spanning-tree** commands in releases earlier than Release 12.2(33)SXI differs from the output in Release 12.2(33)SXI and later releases. The differences are shown in bold in the examples in this section.

This example displays the spanning-tree status:

```
Router# show spanning-tree
VLAN0010
  Spanning tree enabled protocol rstp
  Root ID      Priority    32778
              Address     0002.172c.f400
              This bridge is the root
              Hello Time  2 sec    Max Age 20 sec    Forward Delay 15 sec

  Bridge ID    Priority    32778 (priority 32768 sys-id-ext 10)
```

```

Address      0002.172c.f400
Hello Time   2 sec  Max Age 20 sec  Forward Delay 15 sec
Aging Time  300

```

```

Interface      Role Sts Cost      Prio.Nbr Type
-----
Gi3/14         Desg FWD 4        128.270 Edge, P2p
Router#

```

This example shows the spanning-tree configuration summary:

```
Router# show spanning-tree summary
```

```

Switch is in rapid-pvst mode
Root bridge for:VLAN0010
EtherChannel misconfiguration guard is enabled
Extended system ID is disabled
Portfast is enabled by default
PortFast BPDU Guard is disabled by default
Portfast BPDU Filter is disabled by default
Loopguard is disabled by default
UplinkFast is disabled
BackboneFast is disabled
Pathcost method used is long

```

Name	Blocking	Listening	Learning	Forwarding	STP Active
VLAN0001	0	0	0	1	1
VLAN0010	0	0	0	2	2
2 vlans	0	0	0	3	3

```
Router#
```

This example shows the spanning-tree configuration summary totals:

```
Router# show spanning-tree summary totals
```

```

Switch is in rapid-pvst mode
Root bridge for:VLAN0010
EtherChannel misconfiguration guard is enabled
Extended system ID is disabled
Portfast is enabled by default
PortFast BPDU Guard is disabled by default
Portfast BPDU Filter is disabled by default
Loopguard is disabled by default
UplinkFast is disabled
BackboneFast is disabled
Pathcost method used is long

```

Name	Blocking	Listening	Learning	Forwarding	STP Active
2 vlans	0	0	0	3	3

```
Router#
```

This example shows the spanning-tree configuration details of an edge port:

```
Router# show spanning-tree interface fastEthernet 4/4 detail
```

```

Port 196 (FastEthernet4/4) of VLAN0010 is forwarding
  Port path cost 1000, Port priority 160, Port Identifier 160.196.
  Designated root has priority 32768, address 00d0.00b8.140a
  Designated bridge has priority 32768, address 00d0.00b8.140a
  Designated port id is 160.196, designated path cost 0
  Timers:message age 0, forward delay 0, hold 0
  Number of transitions to forwarding state:1
  The port is in the portfast mode by default

```

```
Link type is point-to-point by default
BPDU:sent 10, received 0
```

This example shows the spanning-tree configuration details of a trunk port:

```
Router(config-if)# spanning-tree portfast trunk
%Warning:portfast should only be enabled on ports connected to a single
  host. Connecting hubs, concentrators, switches, bridges, etc... to this
  interface when portfast is enabled, can cause temporary bridging loops.
  Use with CAUTION

Router(config-if)# ^Z

Router# show spanning-tree interface fastEthernet 4/4 detail
Port 196 (FastEthernet4/4) of VLAN0010 is forwarding
  Port path cost 1000, Port priority 160, Port Identifier 160.196.
  Designated root has priority 32768, address 00d0.00b8.140a
  Designated bridge has priority 32768, address 00d0.00b8.140a
  Designated port id is 160.196, designated path cost 0
  Timers:message age 0, forward delay 0, hold 0
  Number of transitions to forwarding state:1
  The port is in the portfast mode by portfast trunk configuration
  Link type is point-to-point by default
  BPDU:sent 30, received 0
Router#
```

This example shows the spanning tree portfast interface operational state for all the instances:

```
Router# show spanning-tree interface gi3/1 portfast
MST0          disabled
MST1          disabled
```

**Tip**

For additional information about Cisco Catalyst 6500 Series Switches (including configuration examples and troubleshooting information), see the documents listed on this page:

http://www.cisco.com/en/US/products/hw/switches/ps708/tsd_products_support_series_home.html

