



CHAPTER 48

Configuring Dynamic ARP Inspection

This chapter describes how to configure dynamic Address Resolution Protocol (ARP) inspection (DAI) in Cisco IOS Release 12.2SX.



Note

For complete syntax and usage information for the commands used in this chapter, see the Cisco IOS Master Command List, Release 12.2SX, at this URL:

http://www.cisco.com/en/US/docs/ios/mcl/122sxmcl/12_2sx_mcl_book.html



Tip

For additional information about Cisco Catalyst 6500 Series Switches (including configuration examples and troubleshooting information), see the documents listed on this page:

http://www.cisco.com/en/US/products/hw/switches/ps708/tsd_products_support_series_home.html

This chapter consists of these sections:

- [Understanding DAI, page 48-1](#)
- [Default DAI Configuration, page 48-5](#)
- [DAI Configuration Guidelines and Restrictions, page 48-6](#)
- [Configuring DAI, page 48-6](#)
- [DAI Configuration Samples, page 48-15](#)

Understanding DAI

These sections describe how DAI helps prevent ARP spoofing attacks:

- [Understanding ARP, page 48-2](#)
- [Understanding ARP Spoofing Attacks, page 48-2](#)
- [Understanding DAI and ARP Spoofing Attacks, page 48-2](#)

Understanding ARP

ARP provides IP communication within a Layer 2 broadcast domain by mapping an IP address to a MAC address. For example, Host B wants to send information to Host A but does not have the MAC address of Host A in its ARP cache. Host B generates a broadcast message for all hosts within the broadcast domain to obtain the MAC address associated with the IP address of Host A. All hosts within the broadcast domain receive the ARP request, and Host A responds with its MAC address.

Understanding ARP Spoofing Attacks

ARP spoofing attacks and ARP cache poisoning can occur because ARP allows a gratuitous reply from a host even if an ARP request was not received. After the attack, all traffic from the device under attack flows through the attacker's computer and then to the router, switch, or host.

An ARP spoofing attack can target hosts, switches, and routers connected to your Layer 2 network by poisoning the ARP caches of systems connected to the subnet and by intercepting traffic intended for other hosts on the subnet. Figure 48-1 shows an example of ARP cache poisoning.

Figure 48-1 ARP Cache Poisoning

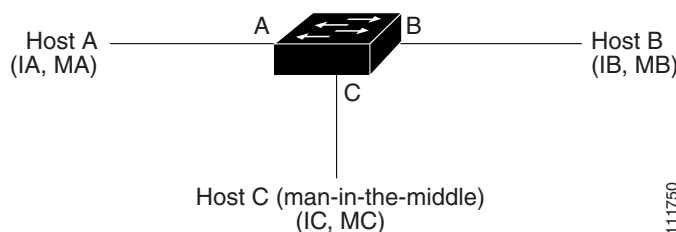

Hosts A, B, and C are connected to the switch on interfaces A, B and C, all of which are on the same subnet. Their IP and MAC addresses are shown in parentheses; for example, Host A uses IP address IA and MAC address MA. When Host A needs to communicate to Host B at the IP layer, it broadcasts an ARP request for the MAC address associated with IP address IB. When the switch and Host B receive the ARP request, they populate their ARP caches with an ARP binding for a host with the IP address IA and a MAC address MA; for example, IP address IA is bound to MAC address MA. When Host B responds, the switch and Host A populate their ARP caches with a binding for a host with the IP address IB and the MAC address MB.

Host C can poison the ARP caches of the switch for Host A, and Host B by broadcasting forged ARP responses with bindings for a host with an IP address of IA (or IB) and a MAC address of MC. Hosts with poisoned ARP caches use the MAC address MC as the destination MAC address for traffic intended for IA or IB. This means that Host C intercepts that traffic. Because Host C knows the true MAC addresses associated with IA and IB, it can forward the intercepted traffic to those hosts by using the correct MAC address as the destination. Host C has inserted itself into the traffic stream from Host A to Host B, which is the topology of the classic *man-in-the middle* attack.

Understanding DAI and ARP Spoofing Attacks

DAI is a security feature that validates ARP packets in a network. DAI intercepts, logs, and discards ARP packets with invalid IP-to-MAC address bindings. This capability protects the network from some man-in-the-middle attacks.

DAI ensures that only valid ARP requests and responses are relayed. The switch performs these activities:

- Intercepts all ARP requests and responses on untrusted ports
- Verifies that each of these intercepted packets has a valid IP-to-MAC address binding before updating the local ARP cache or before forwarding the packet to the appropriate destination
- Drops invalid ARP packets

DAI determines the validity of an ARP packet based on valid IP-to-MAC address bindings stored in a trusted database, the DHCP snooping binding database. This database is built by DHCP snooping if DHCP snooping is enabled on the VLANs and on the switch. If the ARP packet is received on a trusted interface, the switch forwards the packet without any checks. On untrusted interfaces, the switch forwards the packet only if it is valid.

DAI can validate ARP packets against user-configured ARP access control lists (ACLs) for hosts with statically configured IP addresses (see [“Applying ARP ACLs for DAI Filtering”](#) section on page 48-8). The switch logs dropped packets (see the [“Logging of Dropped Packets”](#) section on page 48-5).

You can configure DAI to drop ARP packets when the IP addresses in the packets are invalid or when the MAC addresses in the body of the ARP packets do not match the addresses specified in the Ethernet header (see the [“Enabling Additional Validation”](#) section on page 48-11).

Interface Trust States and Network Security

DAI associates a trust state with each interface on the switch. Packets arriving on trusted interfaces bypass all DAI validation checks, and those arriving on untrusted interfaces undergo the DAI validation process.

In a typical network configuration, you configure all switch ports connected to host ports as untrusted and configure all switch ports connected to switches as trusted. With this configuration, all ARP packets entering the network from a given switch bypass the security check. No other validation is needed at any other place in the VLAN or in the network. You configure the trust setting by using the **ip arp inspection trust** interface configuration command.



Caution

Use the trust state configuration carefully. Configuring interfaces as untrusted when they should be trusted can result in a loss of connectivity.

In [Figure 48-2](#), assume that both Switch A and Switch B are running DAI on the VLAN that includes Host 1 and Host 2. If Host 1 and Host 2 acquire their IP addresses from the DHCP server connected to Switch A, only Switch A binds the IP-to-MAC address of Host 1. Therefore, if the interface between Switch A and Switch B is untrusted, the ARP packets from Host 1 are dropped by Switch B. Connectivity between Host 1 and Host 2 is lost.

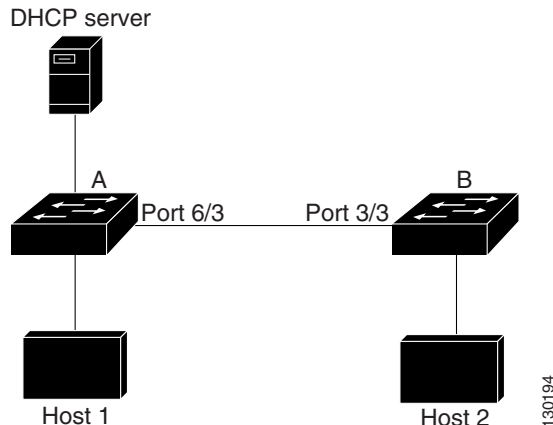
Figure 48-2 ARP Packet Validation on a VLAN Enabled for DAI

Configuring interfaces to be trusted when they are actually untrusted leaves a security hole in the network. If Switch A is not running DAI, Host 1 can easily poison the ARP cache of Switch B (and Host 2, if the link between the switches is configured as trusted). This condition can occur even though Switch B is running DAI.

DAI ensures that hosts (on untrusted interfaces) connected to a switch running DAI do not poison the ARP caches of other hosts in the network. However, DAI does not prevent hosts in other portions of the network from poisoning the caches of the hosts that are connected to a switch running DAI.

In cases in which some switches in a VLAN run DAI and other switches do not, configure the interfaces connecting such switches as untrusted. However, to validate the bindings of packets from switches where DAI is not configured, configure ARP ACLs on the switch running DAI. When you cannot determine such bindings, isolate switches running DAI at Layer 3 from switches not running DAI. For configuration information, see the [“Sample Two: One Switch Supports DAI”](#) section on page 48-20.

**Note**

Depending on the setup of the DHCP server and the network, it might not be possible to validate a given ARP packet on all switches in the VLAN.

Rate Limiting of ARP Packets

The switch performs DAI validation checks, which rate limits incoming ARP packets to prevent a denial-of-service attack. By default, the rate for untrusted interfaces is 15 packets per second (pps). Trusted interfaces are not rate limited. You can change this setting by using the **ip arp inspection limit** interface configuration command.

When the rate of incoming ARP packets exceeds the configured limit, the switch places the port in the error-disabled state. The port remains in that state until you intervene. You can use the **errdisable recovery** global configuration command to enable error disable recovery so that ports automatically emerge from this state after a specified timeout period.

For configuration information, see the [“Configuring ARP Packet Rate Limiting”](#) section on page 48-9.

Relative Priority of ARP ACLs and DHCP Snooping Entries

DAI uses the DHCP snooping binding database for the list of valid IP-to-MAC address bindings.

ARP ACLs take precedence over entries in the DHCP snooping binding database. The switch uses ACLs only if you configure them by using the **ip arp inspection filter** global configuration command. The switch first compares ARP packets to user-configured ARP ACLs. If the ARP ACL denies the ARP packet, the switch also denies the packet even if a valid binding exists in the database populated by DHCP snooping.

Logging of Dropped Packets

When the switch drops a packet, it places an entry in the log buffer and then generates system messages on a rate-controlled basis. After the message is generated, the switch clears the entry from the log buffer. Each log entry contains flow information, such as the receiving VLAN, the port number, the source and destination IP addresses, and the source and destination MAC addresses.

You use the **ip arp inspection log-buffer** global configuration command to configure the number of entries in the buffer and the number of entries needed in the specified interval to generate system messages. You specify the type of packets that are logged by using the **ip arp inspection vlan logging** global configuration command. For configuration information, see the [“Configuring DAI Logging” section on page 48-12](#).

Default DAI Configuration

Table 48-1 shows the default DAI configuration.

Table 48-1 Default DAI Configuration

Feature	Default Setting
DAI	Disabled on all VLANs.
Interface trust state	All interfaces are untrusted.
Rate limit of incoming ARP packets	The rate is 15 pps on untrusted interfaces, assuming that the network is a Layer 2-switched network with a host connecting to as many as 15 new hosts per second. The rate is unlimited on all trusted interfaces. The burst interval is 1 second.
ARP ACLs for non-DHCP environments	No ARP ACLs are defined.
Validation checks	No checks are performed.
Log buffer	When DAI is enabled, all denied or dropped ARP packets are logged. The number of entries in the log is 32. The number of system messages is limited to 5 per second. The logging-rate interval is 1 second.
Per-VLAN logging	All denied or dropped ARP packets are logged.

DAI Configuration Guidelines and Restrictions

When configuring DAI, follow these guidelines and restrictions:

- DAI is an ingress security feature; it does not perform any egress checking.
- DAI is not effective for hosts connected to switches that do not support DAI or that do not have this feature enabled. Because man-in-the-middle attacks are limited to a single Layer 2 broadcast domain, separate the domain with DAI checks from the one with no checking. This action secures the ARP caches of hosts in the domain enabled for DAI.
- DAI depends on the entries in the DHCP snooping binding database to verify IP-to-MAC address bindings in incoming ARP requests and ARP responses. Make sure to enable DHCP snooping to permit ARP packets that have dynamically assigned IP addresses. For configuration information, see [Chapter 46, “Configuring DHCP Snooping.”](#)
- When DHCP snooping is disabled or in non-DHCP environments, use ARP ACLs to permit or to deny packets.
- DAI is supported on access ports, trunk ports, EtherChannel ports, and private VLAN ports.
- A physical port can join an EtherChannel port channel only when the trust state of the physical port and the channel port match. Otherwise, the physical port remains suspended in the port channel. A port channel inherits its trust state from the first physical port that joins the channel. Consequently, the trust state of the first physical port need not match the trust state of the channel.

Conversely, when you change the trust state on the port channel, the switch configures a new trust state on all the physical ports that comprise the channel.

- The operating rate for the port channel is cumulative across all the physical ports within the channel. For example, if you configure the port channel with an ARP rate limit of 400 pps, all the interfaces combined on the channel receive an aggregate 400 pps. The rate of incoming ARP packets on EtherChannel ports is equal to the sum of the incoming rate of packets from all the channel members. Configure the rate limit for EtherChannel ports only after examining the rate of incoming ARP packets on the channel-port members.

The rate of incoming packets on a physical port is checked against the port-channel configuration rather than the physical-ports configuration. The rate-limit configuration on a port channel is independent of the configuration on its physical ports.

If the EtherChannel receives more ARP packets than the configured rate, the channel (including all physical ports) is placed in the error-disabled state.

- Make sure to limit the rate of ARP packets on incoming trunk ports. Configure trunk ports with higher rates to reflect their aggregation and to handle packets across multiple DAI-enabled VLANs. You also can use the **ip arp inspection limit none** interface configuration command to make the rate unlimited. A high rate-limit on one VLAN can cause a denial-of-service attack to other VLANs when the software places the port in the error-disabled state.

Configuring DAI

These sections describe how to configure DAI:

- [Enabling DAI on VLANs, page 48-7](#)
- [Configuring the DAI Interface Trust State, page 48-8](#)
- [Applying ARP ACLs for DAI Filtering, page 48-8](#)

- [Configuring ARP Packet Rate Limiting, page 48-9](#)
- [Enabling DAI Error-Disabled Recovery, page 48-10](#)
- [Enabling Additional Validation, page 48-11](#)
- [Configuring DAI Logging, page 48-12](#)
- [Displaying DAI Information, page 48-14](#)

Enabling DAI on VLANs

To enable DAI on VLANs, perform this task:

	Command	Purpose
Step 1	Router# configure terminal	Enters global configuration mode.
Step 2	Router(config)# ip arp inspection vlan {vlan_ID vlan_range}	Enables DAI on VLANs.
Step 3	Router(config-if)# do show ip arp inspection vlan {vlan_ID vlan_range} begin Vlan	Verifies the configuration.

You can enable DAI on a single VLAN or a range of VLANs:

- To enable a single VLAN, enter a single VLAN number.
- To enable a range of VLANs, enter a dash-separated pair of VLAN numbers.
- You can enter a comma-separated list of VLAN numbers and dash-separated pairs of VLAN numbers.

This example shows how to enable DAI on VLANs 10 through 12:

```
Router# configure terminal
Router(config)# ip arp inspection vlan 10-12
```

This example shows another way to enable DAI on VLANs 10 through 12:

```
Router# configure terminal
Router(config)# ip arp inspection vlan 10,11,12
```

This example shows how to enable DAI on VLANs 10 through 12 and VLAN 15:

```
Router# configure terminal
Router(config)# ip arp inspection vlan 10-12,15
```

This example shows how to verify the configuration:

```
Router(config)# do show ip arp inspection vlan 10-12,15 | begin Vlan
Vlan      Configuration      Operation      ACL Match      Static ACL
-----
    10      Enabled            Inactive
    11      Enabled            Inactive
    12      Enabled            Inactive
    15      Enabled            Inactive

Vlan      ACL Logging        DHCP Logging
-----
    10      Deny               Deny
    11      Deny               Deny
    12      Deny               Deny
    15      Deny               Deny
```

Configuring the DAI Interface Trust State

The switch forwards ARP packets that it receives on a trusted interface, but does not check them.

On untrusted interfaces, the switch intercepts all ARP requests and responses. It verifies that the intercepted packets have valid IP-to-MAC address bindings before updating the local cache and before forwarding the packet to the appropriate destination. The switch drops invalid packets and logs them in the log buffer according to the logging configuration specified with the **ip arp inspection vlan logging** global configuration command. For more information, see the “[Configuring DAI Logging](#)” section on page 48-12.

To configure the DAI interface trust state, perform this task:

	Command	Purpose
Step 1	Router# configure terminal	Enters global configuration mode.
Step 2	Router(config)# interface {type ¹ slot/port port-channel number}	Specifies the interface connected to another switch, and enter interface configuration mode.
Step 3	Router(config-if)# ip arp inspection trust	Configures the connection between switches as trusted.
Step 4	Router(config-if)# do show ip arp inspection interfaces	Verifies the DAI configuration.

1. type = fastethernet, gigabitethernet, or tengigabitethernet

This example shows how to configure Fast Ethernet port 5/12 as trusted:

```
Router# configure terminal
Enter configuration commands, one per line. End with CNTL/Z.
Router(config)# interface fastethernet 5/12
Router(config-if)# ip arp inspection trust
Router(config-if)# do show ip arp inspection interfaces | include Int|--|5/12
Interface          Trust State      Rate (pps)      Burst Interval
-----
Fa5/12             Trusted          None            N/A
```

Applying ARP ACLs for DAI Filtering



Note

See the command reference for information about the **arp access-list** command.

To apply an ARP ACL, perform this task:

	Command	Purpose
Step 1	Router# configure terminal	Enters global configuration mode.
Step 2	Router# ip arp inspection filter arp_acl_name vlan {vlan_ID vlan_range} [static]	Applies the ARP ACL to a VLAN.
Step 3	Router(config)# do show ip arp inspection vlan {vlan_ID vlan_range}	Verifies your entries.

When applying ARP ACLs, note the following information:

- For *vlan_range*, you can specify a single VLAN or a range of VLANs:
 - To specify a single VLAN, enter a single VLAN number.
 - To specify a range of VLANs, enter a dash-separated pair of VLAN numbers.
 - You can enter a comma-separated list of VLAN numbers and dash-separated pairs of VLAN numbers.
- (Optional) Specify **static** to treat implicit denies in the ARP ACL as explicit denies and to drop packets that do not match any previous clauses in the ACL. DHCP bindings are not used.

If you do not specify this keyword, it means that there is no explicit deny in the ACL that denies the packet, and DHCP bindings determine whether a packet is permitted or denied if the packet does not match any clauses in the ACL.

- ARP packets containing only IP-to-MAC address bindings are compared against the ACL. Packets are permitted only if the access list permits them.

This example shows how to apply an ARP ACL named *example_arp_acl* to VLANs 10 through 12 and VLAN 15:

```
Router# configure terminal
Enter configuration commands, one per line. End with CNTL/Z.
Router(config)# ip arp inspection filter example_arp_acl vlan 10-12,15
Router(config)# do show ip arp inspection vlan 10-12,15 | begin Vlan
  Vlan      Configuration      Operation      ACL Match      Static ACL
  ----      -
  10        Enabled             Inactive       example_arp_acl No
  11        Enabled             Inactive       example_arp_acl No
  12        Enabled             Inactive       example_arp_acl No
  15        Enabled             Inactive       example_arp_acl No
Vlan      ACL Logging      DHCP Logging
----      -
  10        Deny              Deny
  11        Deny              Deny
  12        Deny              Deny
  15        Deny              Deny
```

Configuring ARP Packet Rate Limiting

When DAI is enabled, the switch performs ARP packet validation checks, which makes the switch vulnerable to an ARP-packet denial-of-service attack. ARP packet rate limiting can prevent an ARP-packet denial-of-service attack.

To configure ARP packet rate limiting on a port, perform this task:

	Command	Purpose
Step 1	Router# configure terminal	Enters global configuration mode.
Step 2	Router(config)# interface {type ¹ slot/port port-channel number}	Selects the interface to be configured.
Step 3	Router(config-if)# ip arp inspection limit {rate pps [burst interval seconds] none}	(Optional) Configures ARP packet rate limiting.
Step 4	Router(config-if)# do show ip arp inspection interfaces	Verifies the configuration.

1. *type* = fastethernet, gigabitethernet, or tengigabitethernet

When configuring ARP packet rate limiting, note the following information:

- The default rate is 15 pps on untrusted interfaces and unlimited on trusted interfaces.
- For **rate pps**, specify an upper limit for the number of incoming packets processed per second. The range is 0 to 2048 pps.
- The **rate none** keywords specify that there is no upper limit for the rate of incoming ARP packets that can be processed.
- (Optional) For **burst interval seconds** (default is 1), specify the consecutive interval, in seconds, over which the interface is monitored for a high rate of ARP packets. The range is 1 to 15.
- When the rate of incoming ARP packets exceeds the configured limit, the switch places the port in the error-disabled state. The port remains in the error-disabled state until you enable error-disabled recovery, which allows the port to emerge from the error-disabled state after a specified timeout period.
- Unless you configure a rate-limiting value on an interface, changing the trust state of the interface also changes its rate-limiting value to the default value for the configured trust state. After you configure the rate-limiting value, the interface retains the rate-limiting value even when you change its trust state. If you enter the **no ip arp inspection limit** interface configuration command, the interface reverts to its default rate-limiting value.
- For configuration guidelines about limiting the rate of incoming ARP packets on trunk ports and EtherChannel ports, see the “[DAI Configuration Guidelines and Restrictions](#)” section on page 48-6.

This example shows how to configure ARP packet rate limiting on Fast Ethernet port 5/14:

```
Router# configure terminal
Enter configuration commands, one per line. End with CNTL/Z.
Router(config)# interface fastethernet 5/14
Router(config-if)# ip arp inspection limit rate 20 burst interval 2
Router(config-if)# do show ip arp inspection interfaces | include Int|--|5/14
Interface      Trust State      Rate (pps)      Burst Interval
-----
Fa5/14         Untrusted        20              2
```

Enabling DAI Error-Disabled Recovery

To enable DAI error-disabled recovery, perform this task:

	Command	Purpose
Step 1	Router# configure terminal	Enters global configuration mode.
Step 2	Router(config)# errdisable recovery cause arp-inspection	(Optional) Enables DAI error-disabled recovery.
Step 3	Router(config)# do show errdisable recovery include Reason --- arp-	Verifies the configuration.

This example shows how to enable DAI error disabled recovery:

```
Router# configure terminal
Enter configuration commands, one per line. End with CNTL/Z.
Router(config)# errdisable recovery cause arp-inspection
Router(config)# do show errdisable recovery | include Reason|---|arp-
ErrDisable Reason      Timer Status
-----
arp-inspection         Enabled
```

Enabling Additional Validation

DAI intercepts, logs, and discards ARP packets with invalid IP-to-MAC address bindings. You can enable additional validation on the destination MAC address, the sender and target IP addresses, and the source MAC address.

To enable additional validation, perform this task:

	Command	Purpose
Step 1	Router# configure terminal	Enters global configuration mode.
Step 2	Router(config)# ip arp inspection validate {[dst-mac] [ip] [src-mac]}	(Optional) Enables additional validation.
Step 3	Router(config)# do show ip arp inspection include abled\$	Verifies the configuration.

The additional validations do the following:

- **dst-mac**—Checks the destination MAC address in the Ethernet header against the target MAC address in ARP body. This check is performed for ARP responses. When enabled, packets with different MAC addresses are classified as invalid and are dropped.
- **ip**—Checks the ARP body for invalid and unexpected IP addresses. Addresses include 0.0.0.0, 255.255.255.255, and all IP multicast addresses. Sender IP addresses are checked in all ARP requests and responses, and target IP addresses are checked only in ARP responses.
- **src-mac**—Checks the source MAC address in the Ethernet header against the sender MAC address in the ARP body. This check is performed on both ARP requests and responses. When enabled, packets with different MAC addresses are classified as invalid and are dropped.

When enabling additional validation, note the following information:

- You must specify at least one of the keywords.
- Each **ip arp inspection validate** command overrides the configuration from any previous commands. If an **ip arp inspection validate** command enables **src-mac** and **dst-mac** validations, and a second **ip arp inspection validate** command enables IP validation only, the **src-mac** and **dst-mac** validations are disabled as a result of the second command.

This example shows how to enable **src-mac** additional validation:

```
Router# configure terminal
Enter configuration commands, one per line. End with CNTL/Z.
Router(config)# ip arp inspection validate src-mac
Router(config)# do show ip arp inspection | include abled$
Source Mac Validation      : Enabled
Destination Mac Validation : Disabled
IP Address Validation      : Disabled
```

This example shows how to enable **dst-mac** additional validation:

```
Router# configure terminal
Enter configuration commands, one per line. End with CNTL/Z.
Router(config)# ip arp inspection validate dst-mac
Router(config)# do show ip arp inspection | include abled$
Source Mac Validation      : Disabled
Destination Mac Validation : Enabled
IP Address Validation      : Disabled
```

This example shows how to enable **ip** additional validation:

```
Router# configure terminal
Enter configuration commands, one per line. End with CNTL/Z.
Router(config)# ip arp inspection validate ip
Router(config)# do show ip arp inspection | include abled$
Source Mac Validation      : Disabled
Destination Mac Validation : Disabled
IP Address Validation      : Enabled
```

This example shows how to enable **src-mac** and **dst-mac** additional validation:

```
Router# configure terminal
Enter configuration commands, one per line. End with CNTL/Z.
Router(config)# ip arp inspection validate src-mac dst-mac
Router(config)# do show ip arp inspection | include abled$
Source Mac Validation      : Enabled
Destination Mac Validation : Enabled
IP Address Validation      : Disabled
```

This example shows how to enable **src-mac**, **dst-mac**, and **ip** additional validation:

```
Router# configure terminal
Enter configuration commands, one per line. End with CNTL/Z.
Router(config)# ip arp inspection validate src-mac dst-mac ip
Router(config)# do show ip arp inspection | include abled$
Source Mac Validation      : Enabled
Destination Mac Validation : Enabled
IP Address Validation      : Enabled
```

Configuring DAI Logging

These sections describe DAI logging:

- [DAI Logging Overview, page 48-12](#)
- [Configuring the DAI Logging Buffer Size, page 48-13](#)
- [Configuring the DAI Logging System Messages, page 48-13](#)
- [Configuring DAI Log Filtering, page 48-14](#)

DAI Logging Overview

When DAI drops a packet, it places an entry in the log buffer and then generates system messages on a rate-controlled basis. After the message is generated, DAI clears the entry from the log buffer. Each log entry contains flow information, such as the receiving VLAN, the port number, the source and destination IP addresses, and the source and destination MAC addresses.

A log-buffer entry can represent more than one packet. For example, if an interface receives many packets on the same VLAN with the same ARP parameters, DAI combines the packets as one entry in the log buffer and generates a single system message for the entry.

If the log buffer overflows, it means that a log event does not fit into the log buffer, and the display for the **show ip arp inspection log** privileged EXEC command is affected. Two dashes (“--”) appear instead of data except for the packet count and the time. No other statistics are provided for the entry. If you see this entry in the display, increase the number of entries in the log buffer or increase the logging rate.

Configuring the DAI Logging Buffer Size

To configure the DAI logging buffer size, perform this task:

	Command	Purpose
Step 1	Router# configure terminal	Enters global configuration mode.
Step 2	Router(config)# ip arp inspection log-buffer entries <i>number</i>	Configures the DAI logging buffer size (range is 0 to 1024).
Step 3	Router(config)# do show ip arp inspection log include Size	Verifies the configuration.

This example shows how to configure the DAI logging buffer for 64 messages:

```
Router# configure terminal
Enter configuration commands, one per line. End with CNTL/Z.
Router(config)# ip arp inspection log-buffer entries 64
Router(config)# do show ip arp inspection log | include Size
Total Log Buffer Size : 64
```

Configuring the DAI Logging System Messages

To configure the DAI logging system messages, perform this task:

	Command	Purpose
Step 1	Router# configure terminal	Enters global configuration mode.
Step 2	Router(config)# ip arp inspection log-buffer logs <i>number_of_messages interval length_in_seconds</i>	Configures the DAI logging buffer.
Step 3	Router(config)# do show ip arp inspection log	Verifies the configuration.

When configuring the DAI logging system messages, note the following information:

- For **logs** *number_of_messages* (default is 5), the range is 0 to 1024. A 0 value means that the entry is placed in the log buffer, but a system message is not generated.
- For **interval** *length_in_seconds* (default is 1), the range is 0 to 86400 seconds (1 day). A 0 value means that a system message is immediately generated (and the log buffer is always empty). An interval setting of 0 overrides a log setting of 0.
- System messages are sent at the rate of *number_of_messages* per *length_in_seconds*.

This example shows how to configure DAI logging to send 12 messages every 2 seconds:

```
Router# configure terminal
Enter configuration commands, one per line. End with CNTL/Z.
Router(config)# ip arp inspection log-buffer logs 12 interval 2
Router(config)# do show ip arp inspection log | include Syslog
Syslog rate : 12 entries per 2 seconds.
```

This example shows how to configure DAI logging to send 20 messages every 60 seconds.

```
Router# configure terminal
Enter configuration commands, one per line. End with CNTL/Z.
Router(config)# ip arp inspection log-buffer logs 20 interval 60
Router(config)# do show ip arp inspection log | include Syslog
Syslog rate : 20 entries per 60 seconds.
```

Configuring DAI Log Filtering

To configure DAI log filtering, perform this task:

	Command	Purpose
Step 1	Router# configure terminal	Enters global configuration mode.
Step 2	Router(config)# ip arp inspection vlan <i>vlan_range</i> logging { acl-match { matchlog none } dhcp-bindings { all none permit }}	Configures log filtering for each VLAN.
Step 3	Router(config)# do show running-config include ip arp inspection vlan <i>vlan_range</i>	Verifies the configuration.

When configuring the DAI log filtering, note the following information:

- By default, all denied packets are logged.
- For *vlan_range*, you can specify a single VLAN or a range of VLANs:
 - To specify a single VLAN, enter a single VLAN number.
 - To specify a range of VLANs, enter a dash-separated pair of VLAN numbers.
 - You can enter a comma-separated list of VLAN numbers and dash-separated pairs of VLAN numbers.
- **acl-match matchlog**—Logs packets based on the DAI ACL configuration. If you specify the **matchlog** keyword in this command and the **log** keyword in the **permit** or **deny** ARP access-list configuration command, ARP packets permitted or denied by the ACL are logged.
- **acl-match none**—Does not log packets that match ACLs.
- **dhcp-bindings all**—Logs all packets that match DHCP bindings.
- **dhcp-bindings none**—Does not log packets that match DHCP bindings.
- **dhcp-bindings permit**—Logs DHCP-binding permitted packets.

This example shows how to configure the DAI log filtering for VLAN 100 not to log packets that match ACLs:

```
Router# configure terminal
Enter configuration commands, one per line. End with CNTL/Z.
Router(config)# ip arp inspection vlan 100 logging acl-match none
Router(config)# do show running-config | include ip arp inspection vlan 100
ip arp inspection vlan 100 logging acl-match none
```

Displaying DAI Information

To display DAI information, use the privileged EXEC commands described in [Table 48-2](#).

Table 48-2 Commands for Displaying DAI Information

Command	Description
show arp access-list [<i>acl_name</i>]	Displays detailed information about ARP ACLs.

Table 48-2 *Commands for Displaying DAI Information (continued)*

Command	Description
show ip arp inspection interfaces [<i>interface_id</i>]	Displays the trust state and the rate limit of ARP packets for the specified interface or all interfaces.
show ip arp inspection vlan <i>vlan_range</i>	Displays the configuration and the operating state of DAI for the specified VLAN. If no VLANs are specified or if a range is specified, displays information only for VLANs with DAI enabled (active).

To clear or display DAI statistics, use the privileged EXEC commands in [Table 48-3](#).

Table 48-3 *Commands for Clearing or Displaying DAI Statistics*

Command	Description
clear ip arp inspection statistics	Clears DAI statistics.
show ip arp inspection statistics [<i>vlan vlan_range</i>]	Displays statistics for forwarded, dropped, MAC validation failure, IP validation failure, ACL permitted and denied, and DHCP permitted and denied packets for the specified VLAN. If no VLANs are specified or if a range is specified, displays information only for VLANs with DAI enabled (active).

For the **show ip arp inspection statistics** command, the switch increments the number of forwarded packets for each ARP request and response packet on a trusted DAI port. The switch increments the number of ACL-permitted or DHCP-permitted packets for each packet that is denied by source MAC, destination MAC, or IP validation checks, and the switch increments the appropriate failure count.

To clear or display DAI logging information, use the privileged EXEC commands in [Table 48-4](#):

Table 48-4 *Commands for Clearing or Displaying DAI Logging Information*

Command	Description
clear ip arp inspection log	Clears the DAI log buffer.
show ip arp inspection log	Displays the configuration and contents of the DAI log buffer.

DAI Configuration Samples

This section includes these samples:

- [Sample One: Two Switches Support DAI, page 48-16](#)
- [Sample Two: One Switch Supports DAI, page 48-20](#)

Sample One: Two Switches Support DAI

This procedure shows how to configure DAI when two switches support this feature. Host 1 is connected to Switch A, and Host 2 is connected to Switch B as shown in [Figure 48-2 on page 48-4](#). Both switches are running DAI on VLAN 1 where the hosts are located. A DHCP server is connected to Switch A. Both hosts acquire their IP addresses from the same DHCP server. Switch A has the bindings for Host 1 and Host 2, and Switch B has the binding for Host 2. Switch A Fast Ethernet port 6/3 is connected to the Switch B Fast Ethernet port 3/3.



Note

- DAI depends on the entries in the DHCP snooping binding database to verify IP-to-MAC address bindings in incoming ARP requests and ARP responses. Make sure to enable DHCP snooping to permit ARP packets that have dynamically assigned IP addresses. For configuration information, see [Chapter 46, “Configuring DHCP Snooping.”](#)
- This configuration does not work if the DHCP server is moved from Switch A to a different location.
- To ensure that this configuration does not compromise security, configure Fast Ethernet port 6/3 on Switch A and Fast Ethernet port 3/3 on Switch B as trusted.

Configuring Switch A

To enable DAI and configure Fast Ethernet port 6/3 on Switch A as trusted, follow these steps:

Step 1 Verify the connection between switches Switch A and Switch B:

```
SwitchA# show cdp neighbors
Capability Codes: R - Router, T - Trans Bridge, B - Source Route Bridge
                  S - Switch, H - Host, I - IGMP, r - Repeater, P - Phone

Device ID         Local Intrfce   Holdtme    Capability  Platform  Port ID
SwitchB          Fas 6/3        177        R S I      WS-C6506  Fas 3/3
SwitchA#
```

Step 2 Enable DAI on VLAN 1 and verify the configuration:

```
SwitchA# configure terminal
Enter configuration commands, one per line.  End with CNTL/Z.
SwitchA(config)# ip arp inspection vlan 1
SwitchA(config)# end
SwitchA# show ip arp inspection vlan 1

Source Mac Validation      : Disabled
Destination Mac Validation : Disabled
IP Address Validation      : Disabled

Vlan    Configuration  Operation  ACL Match  Static ACL
----    -
      1    Enabled      Active

Vlan    ACL Logging     DHCP Logging
----    -
      1    Deny           Deny
SwitchA#
```

Step 3 Configure Fast Ethernet port 6/3 as trusted:

```
SwitchA# configure terminal
```

```

Enter configuration commands, one per line. End with CNTL/Z.
SwitchA(config)# interface fastethernet 6/3
SwitchA(config-if)# ip arp inspection trust
SwitchA(config-if)# end
SwitchA# show ip arp inspection interfaces fastethernet 6/3

```

```

Interface          Trust State      Rate (pps)
-----
Fa6/3              Trusted          None
SwitchA#

```

Step 4 Verify the bindings:

```

SwitchA# show ip dhcp snooping binding
MacAddress          IPAddress        Lease(sec)  Type           VLAN  Interface
-----
00:02:00:02:00:02  1.1.1.2         4993       dhcp-snooping  1     FastEthernet6/4
SwitchA#

```

Step 5 Check the statistics before and after DAI processes any packets:

```

SwitchA# show ip arp inspection statistics vlan 1

Vlan      Forwarded      Dropped      DHCP Drops      ACL Drops
-----
1         0              0            0              0

Vlan      DHCP Permits   ACL Permits   Source MAC Failures
-----
1         0              0            0

Vlan      Dest MAC Failures  IP Validation Failures
-----
1         0                0

SwitchA#

```

If Host 1 then sends out two ARP requests with an IP address of 1.1.1.2 and a MAC address of 0002.0002.0002, both requests are permitted, as reflected in the following statistics:

```

SwitchA# show ip arp inspection statistics vlan 1

Vlan      Forwarded      Dropped      DHCP Drops      ACL Drops
-----
1         2              0            0              0

Vlan      DHCP Permits   ACL Permits   Source MAC Failures
-----
1         2              0            0

Vlan      Dest MAC Failures  IP Validation Failures
-----
1         0                0

SwitchA#

```

If Host 1 then tries to send an ARP request with an IP address of 1.1.1.3, the packet is dropped and an error message is logged:

```

00:12:08: %SW_DAI-4-DHCP_SNOOPING_DENY: 2 Invalid ARPs (Req) on Fa6/4, vlan
1. ([0002.0002.0002/1.1.1.3/0000.0000.0000/0.0.0.0/02:42:35 UTC Tue Jul 10 2001])
SwitchA# show ip arp inspection statistics vlan 1
SwitchA#

```

The statistics will display as follows:

```

Vlan      Forwarded      Dropped      DHCP Drops      ACL Drops

```

```

-----
 1           2           2           2           0
Vlan  DHCP Permits   ACL Permits   Source MAC Failures
-----
 1           2           0           0
Vlan  Dest MAC Failures   IP Validation Failures
-----
 1           0           0
SwitchA#

```

Configuring Switch B

To enable DAI and configure Fast Ethernet port 3/3 on Switch B as trusted, follow these steps:

Step 1 Verify the connectivity:

```

SwitchA# show cdp neighbors
Capability Codes: R - Router, T - Trans Bridge, B - Source Route Bridge
                  S - Switch, H - Host, I - IGMP, r - Repeater, P - Phone

Device ID      Local Intrfce   Holdtme    Capability   Platform   Port ID
SwitchB        Fas 3/3         120        R S I       WS-C6506   Fas 6/3
SwitchB#

```

Step 2 Enable DAI on VLAN 1, and verify the configuration:

```

SwitchB# configure terminal
Enter configuration commands, one per line. End with CNTL/Z.
SwitchB(config)# ip arp inspection vlan 1
SwitchB(config)# end
SwitchB# show ip arp inspection vlan 1

Source Mac Validation      : Disabled
Destination Mac Validation : Disabled
IP Address Validation      : Disabled

Vlan  Configuration  Operation  ACL Match  Static ACL
-----
 1    Enabled        Active

Vlan  ACL Logging  DHCP Logging
-----
 1    Deny        Deny
SwitchB#

```

Step 3 Configure Fast Ethernet port 3/3 as trusted:

```

SwitchB# configure terminal
Enter configuration commands, one per line. End with CNTL/Z.
SwitchB(config)# interface fastethernet 3/3
SwitchB(config-if)# ip arp inspection trust
SwitchB(config-if)# end
SwitchB# show ip arp inspection interfaces

Interface      Trust State  Rate (pps)
-----
Gi1/1         Untrusted   15

```

```

Gi1/2          Untrusted          15
Gi3/1          Untrusted          15
Gi3/2          Untrusted          15
Fa3/3          Trusted             None
Fa3/4          Untrusted          15
Fa3/5          Untrusted          15
Fa3/6          Untrusted          15
Fa3/7          Untrusted          15

```

```

<output truncated>
SwitchB#

```

Step 4 Verify the list of DHCP snooping bindings:

```

SwitchB# show ip dhcp snooping binding
-----
MacAddress      IPAddress      Lease(sec)    Type           VLAN  Interface
-----
00:01:00:01:00:01  1.1.1.1      4995          dhcp-snooping  1    FastEthernet3/4
SwitchB#

```

Step 5 Check the statistics before and after DAI processes any packets:

```

SwitchB# show ip arp inspection statistics vlan 1
-----
Vlan      Forwarded      Dropped      DHCP Drops      ACL Drops
-----
1         0              0            0               0

Vlan      DHCP Permits   ACL Permits   Source MAC Failures
-----
1         0              0            0

Vlan      Dest MAC Failures  IP Validation Failures
-----
1         0                  0

SwitchB#

```

If Host 2 then sends out an ARP request with the IP address 1.1.1.1 and the MAC address 0001.0001.0001, the packet is forwarded and the statistics are updated appropriately:

```

SwitchB# show ip arp inspection statistics vlan 1
-----
Vlan      Forwarded      Dropped      DHCP Drops      ACL Drops
-----
1         1              0            0               0

Vlan      DHCP Permits   ACL Permits   Source MAC Failures
-----
1         1              0            0

Vlan      Dest MAC Failures  IP Validation Failures
-----
1         0                  0

SwitchB#

```

If Host 2 attempts to send an ARP request with the IP address 1.1.1.2, DAI drops the request and logs a system message:

```

00:18:08: %SW_DAI-4-DHCP_SNOOPING_DENY: 1 Invalid ARPs (Req) on Fa3/4, vlan
1. ([0001.0001.0001/1.1.1.2/0000.0000.0000/0.0.0.0/01:53:21 UTC Fri May 23 2003])
SwitchB#

```

The statistics display as follows:

```

SwitchB# show ip arp inspection statistics vlan 1

```

```

Vlan      Forwarded      Dropped      DHCP Drops      ACL Drops
----      -
1         1              1            1              0

Vlan      DHCP Permits    ACL Permits    Source MAC Failures
----      -
1         1              0            0

Vlan      Dest MAC Failures  IP Validation Failures
----      -
1         0              0

SwitchB#

```

Sample Two: One Switch Supports DAI

This procedure shows how to configure DAI when Switch B shown in [Figure 48-2 on page 48-4](#) does not support DAI or DHCP snooping.

If switch Switch B does not support DAI or DHCP snooping, configuring Fast Ethernet port 6/3 on Switch A as trusted creates a security hole because both Switch A and Host 1 could be attacked by either Switch B or Host 2.

To prevent this possibility, you must configure Fast Ethernet port 6/3 on Switch A as untrusted. To permit ARP packets from Host 2, you must set up an ARP ACL and apply it to VLAN 1. If the IP address of Host 2 is not static, which would make it impossible to apply the ACL configuration on Switch A, you must separate Switch A from Switch B at Layer 3 and use a router to route packets between them.

To set up an ARP ACL on switch Switch A, follow these steps:

- Step 1** Configure the access list to permit the IP address 1.1.1.1 and the MAC address 0001.0001.0001, and verify the configuration:

```

SwitchA# configure terminal
Enter configuration commands, one per line. End with CNTL/Z.
SwitchA(config)# arp access-list H2
SwitchA(config-arp-nacl)# permit ip host 1.1.1.1 mac host 1.1.1
SwitchA(config-arp-nacl)# end
SwitchA# show arp access-list
ARP access list H2
    permit ip host 1.1.1.1 mac host 0001.0001.0001

```

- Step 2** Apply the ACL to VLAN 1, and verify the configuration:

```

SwitchA# configure terminal
Enter configuration commands, one per line. End with CNTL/Z.
SwitchA(config)# ip arp inspection filter H2 vlan 1
SwitchA(config)# end
SwitchA#

SwitchA# show ip arp inspection vlan 1

Source Mac Validation      : Disabled
Destination Mac Validation : Disabled
IP Address Validation      : Disabled

Vlan      Configuration      Operation      ACL Match      Static ACL
----      -

```

```

      1      Enabled          Active      H2          No

Vlan    ACL Logging      DHCP Logging
----    -
      1      Deny          Deny
SwitchA#

```

Step 3 Configure Fast Ethernet port 6/3 as untrusted, and verify the configuration:

```

SwitchA# configure terminal
Enter configuration commands, one per line. End with CNTL/Z.
SwitchA(config)# interface fastethernet 6/3
SwitchA(config-if)# no ip arp inspection trust
SwitchA(config-if)# end
Switch# show ip arp inspection interfaces fastethernet 6/3

Interface          Trust State      Rate (pps)
-----
Fa6/3              Untrusted       15

Switch#

```

When Host 2 sends 5 ARP requests through Fast Ethernet port 6/3 on Switch A and a “get” is permitted by Switch A, the statistics are updated appropriately:

```

Switch# show ip arp inspection statistics vlan 1
Vlan    Forwarded      Dropped      DHCP Drops      ACL Drops
----    -
      1          5            0            0              0
Vlan    DHCP Permits   ACL Permits   Source MAC Failures
----    -
      1          0            5            0
Vlan    Dest MAC Failures  IP Validation Failures
----    -
      1          0            0
Switch#

```



Tip

For additional information about Cisco Catalyst 6500 Series Switches (including configuration examples and troubleshooting information), see the documents listed on this page:

http://www.cisco.com/en/US/products/hw/switches/ps708/tsd_products_support_series_home.html

