

Configuring Network Security with ACLs

This chapter describes how to use access control lists (ACLs) to configure network security on the Catalyst 4500 series switches.

**Note**

The Catalyst 4500 series switch supports “time-based ACLs”.

**Note**

For complete syntax and usage information for the switch commands used in this chapter, refer to the *Catalyst 4500 Series Switch Cisco IOS Command Reference* and related publications at this location:

<http://www.cisco.com/univercd/cc/td/doc/product/software/ios122sr/cr/index.htm>

When you trace this URL, you can access information on time-based ACLs through the link.

http://www.cisco.com/en/US/docs/ios/security/command/reference/sec_a2.html#wp1058483

This chapter consists of the following major sections:

- [Understanding ACLs, page 43-2](#)
- [Hardware and Software ACL Support, page 43-5](#)
- [TCAM Programming and ACLs for Supervisor Engine II-Plus, Supervisor Engine IV, Supervisor Engine V, and Supervisor Engine V-10GE, page 43-6](#)
- [TCAM Programming and ACLs for Supervisor Engine 6-E, page 43-15](#)
- [Layer 4 Operators in ACLs, page 43-15](#)
- [Configuring Unicast MAC Address Filtering, page 43-19](#)
- [Configuring Named MAC Extended ACLs, page 43-19](#)
- [Configuring Named IPv6 ACLs, page 43-20](#)
- [Applying IPv6 ACLs to a Layer 3 Interface, page 43-21](#)
- [Configuring VLAN Maps, page 43-22](#)
- [Displaying VLAN Access Map Information, page 43-29](#)
- [Using VLAN Maps with Router ACLs, page 43-29](#)
- [Configuring PACLs, page 43-32](#)
- [Using PACL with VLAN Maps and Router ACLs, page 43-36](#)

**Note**

The following discussions applies to both Supervisor Engine 6-E and non-Supervisor Engine 6-E configurations unless noted otherwise.

Understanding ACLs

This section contains the following subsections:

- [ACL Overview, page 43-2](#)
- [Supported Features That Use ACLs, page 43-3](#)
- [Router ACLs, page 43-3](#)
- [Port ACLs, page 43-4](#)
- [VLAN Maps, page 43-5](#)

ACL Overview

An ACL is a collection of sequential permit and deny conditions that applies to packets. When a packet is received on an interface, the switch compares the fields in the packet against any applied ACLs to verify that the packet has the permissions required to be forwarded, based on the conditions specified in the access lists. It tests the packets against the conditions in an access list one-by-one. The first match determines whether the switch accepts or rejects the packets. Because the switch stops testing conditions after the first match, the order of conditions in the list is critical. If no conditions match, the switch drops the packet. If there are no restrictions, the switch forwards the packet; otherwise, the switch drops the packet.

Switches traditionally operate at Layer 2, switching traffic within a VLAN, whereas routers route traffic between VLANs at Layer 3. The Catalyst 4500 series switch can accelerate packet routing between VLANs by using Layer 3 switching. The Layer 3 switch bridges the packet, and then routes the packet internally without going to an external router. The packet is then bridged again and sent to its destination. During this process, the switch can control all packets, including packets bridged within a VLAN.

You configure access lists on a router or switch to filter traffic and provide basic security for your network. If you do not configure ACLs, all packets passing through the switch could be allowed on all parts of the network. You can use ACLs to control which hosts can access different parts of a network or to decide which types of traffic are forwarded or blocked at router interfaces. For example, you can allow e-mail traffic to be forwarded but not Telnet traffic. ACLs can be configured to block inbound traffic, outbound traffic, or both. However, on Layer 2 interfaces, you can apply ACLs only in the inbound direction.

An ACL contains an ordered list of access control entries (ACEs). Each ACE specifies permit or deny and a set of conditions the packet must satisfy in order to match the ACE. The meaning of permit or deny depends on the context in which the ACL is used.

The Catalyst 4500 series switch supports three types of ACLs:

- IP ACLs, which filter IP traffic, including TCP, the User Datagram Protocol (UDP), Internet Group Management Protocol (IGMP), and Internet Control Message Protocol (ICMP).
- IPv6 ACLs (applies only to Supervisor Engine 6E).

Supported Features That Use ACLs

The switch supports two applications of ACLs to filter traffic:

- Router ACLs are applied to Layer 3 interfaces. They control the access of routed traffic between VLANs. All Catalyst 4500 series switches can create router ACLs, but you must have a Cisco IOS software image on your switch to apply an ACL to a Layer 3 interface and filter packets routed between VLANs.
- Port ACLs perform access control on traffic entering a Layer 2 interface. If there are not enough hardware CAM entries, the output port ACL is not applied to the port and a warning message is given to user. (This restriction applies to all access group modes for output port ACLs.) When there are enough CAM entries, the output port ACL might be reapplied.

If there is any output port ACL configured on a Layer 2 port, then no VACL or router ACL can be configured on the VLANs that the Layer 2 port belongs to. Also, the reverse is true: port ACLs and VLAN-based ACLs (VACLs and router ACLs) are mutually exclusive on a Layer 2 port. This restriction applies to all access group modes. On the input direction, port ACLs, VLAN-based ACLs, and router ACLs can co-exist.

You can apply only one IP access list, one MAC access list for a Layer 2 interface.

- VLAN ACLs or VLAN maps control the access of all packets (bridged and routed). You can use VLAN maps to filter traffic between devices in the same VLAN. You do not need the enhanced image to create or apply VLAN maps. VLAN maps are configured to control access based on Layer 3 addresses for IP. MAC addresses using Ethernet ACEs control the access of unsupported protocols. After you apply a VLAN map to a VLAN, all packets (routed or bridged) entering the VLAN are checked against that map. Packets can either enter the VLAN through a switch port or through a routed port after being routed.

You can use both router ACLs and VLAN maps on the same switch.

Router ACLs

You can apply one access-list of each supported type to an interface.



Note

Catalyst 4500 series switches running Cisco IOS Release 12.2(40)SG do *not* support IPv6 Port ACLs (PACLs).

Multiple features can use one ACL for a given interface, and one feature can use multiple ACLs. When a single router ACL is used by multiple features, it is examined multiple times. The access list type determines the input to the matching operation:

- Standard IP access lists use source addresses for matching operations.
- Extended IP access lists use source and destination addresses and optional protocol type information for matching operations.

The switch examines ACLs associated with features configured on a given interface and a direction. As packets enter the switch on an interface, ACLs associated with all inbound features configured on that interface are examined. After packets are routed and before they are forwarded to the next hop, all ACLs associated with outbound features configured on the egress interface are examined.

ACLs permit or deny packet forwarding based on how the packet matches the entries in the ACL. For example, you can use access lists to allow one host to access a part of a network, but prevent another host from accessing the same part. In [Figure 43-1](#), ACLs applied at the router input allow Host A to access the Human Resources network, but prevent Host B from accessing the same network.

Figure 43-1 Using ACLs to Control Traffic to a Network

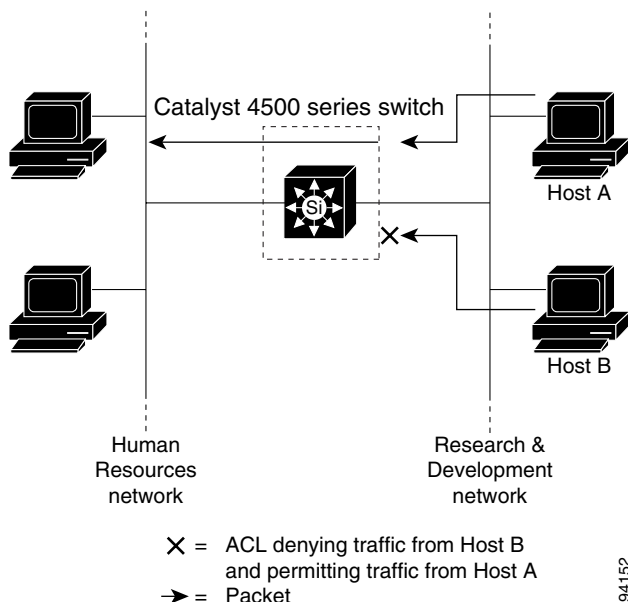

Port ACLs

You can also apply ACLs to Layer 2 interfaces on a switch. Port ACLs are supported on physical interfaces and EtherChannel interfaces.

The following access lists are supported on Layer 2 interfaces:

- Standard IP access lists using source addresses
- Extended IP access lists using source and destination addresses and optional protocol type information
- MAC extended access lists using source and destination MAC addresses and optional protocol type information

As with router ACLs, the switch examines ACLs associated with features configured on a given interface and permits or denies packet forwarding based on how the packet matches the entries in the ACL. In the example in [Figure 43-1](#), if all workstations were in the same VLAN, ACLs applied at the Layer 2 input would allow Host A to access the Human Resources network, but prevent Host B from accessing the same network.

When you apply a port ACL to a trunk port, the ACL filters traffic on all VLANs present on the trunk port. When you apply a port ACL to a port with voice VLAN, the ACL filters traffic on both data and voice VLANs.

With port ACLs, you can filter IP traffic by using IP access lists and non-IP traffic by using MAC addresses. You can filter both IP and non-IP traffic on the same Layer 2 interface by applying both an IP access list and a MAC access list to the interface.

**Note**

You cannot apply more than one IP access list and one MAC access list to a Layer 2 interface. If an IP access list or MAC access list is already configured on a Layer 2 interface and you apply a new IP access list or MAC access list to the interface, the new ACL replaces the previously configured one.

VLAN Maps

VLAN maps can control the access of all traffic in a VLAN. You can apply VLAN maps on the switch to all packets that are routed into or out of a VLAN or are bridged within a VLAN. Unlike router ACLs, VLAN maps are not defined by direction (input or output).

You can configure VLAN maps to match Layer 3 addresses for IP traffic. Access of all non-IP protocols is controlled with a MAC address and an Ethertype using MAC ACLs in VLAN maps. (IP traffic is not controlled by MAC ACLs in VLAN maps.) You can enforce VLAN maps only on packets going through the switch; you cannot enforce VLAN maps on traffic between hosts on a hub or on another switch connected to this switch.

With VLAN maps, forwarding packets is permitted or denied, based on the action specified in the map. [Figure 43-2](#) illustrates how a VLAN map is applied to deny a specific type of traffic from Host A in VLAN 10 from being forwarded.

Figure 43-2 Using VLAN Maps to Control Traffic

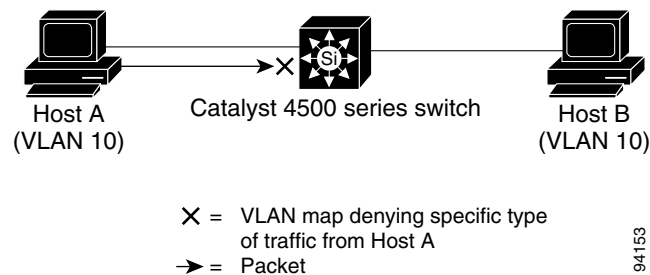

Hardware and Software ACL Support

This section describes how to determine whether ACLs are processed in hardware or in software:

- Flows that match a deny statement in standard and extended ACLs are dropped in hardware if ICMP unreachable messages are disabled.
- Flows that match a permit statement in standard ACLs are processed in hardware.
- The following ACL types are not supported in software:
 - Standard Xerox Network Systems (XNS) Protocol access list
 - Extended XNS access list
 - DECnet access list

- Protocol type-code access list
- Standard Internet Packet Exchange (IPX) access list
- Extended IPX access list

**Note**

Packets that require logging are processed in software. A copy of the packets is sent to the CPU for logging while the actual packets are forwarded in hardware so that non-logged packet processing is not impacted.

By default, the Catalyst 4500 series switch sends ICMP unreachable messages when a packet is denied by an access list; these packets are not dropped in hardware but are forwarded to the switch so that it can generate the ICMP unreachable message.

To drop access-list denied packets in hardware on the input interface, you must disable ICMP unreachable messages using the **no ip unreachable** interface configuration command. The **ip unreachable** command is enabled by default.

**Note**

Cisco IOS Release 12.2(40)SG does not support disabling ip unreachable on interfaces routing IPv6 traffic.

**Note**

If you set the **no ip unreachable** command on all Layer 3 interfaces, output ACL denied packets do not come to the CPU.

TCAM Programming and ACLs for Supervisor Engine II-Plus, Supervisor Engine IV, Supervisor Engine V, and Supervisor Engine V-10GE

TCAM entry and mask utilization on the Catalyst 4500 series switch is based on the following elements:

- ACL configuration
- Supervisor model
- IOS software version

For Supervisor Engine II-Plus-10GE, Supervisor Engine V-10GE, and the Catalyst 4948-10GE switch, the entry and mask utilization equals the number of ACEs in the ACL configuration divided by the number of entries in the TCAM region, regardless of IOS software version. Optimized TCAM utilization is not required.

For Supervisor Engine II-Plus-TS, Supervisor Engines IV, Supervisor Engines V, and the Catalyst 4948 switch, up to eight entries share a single mask in the TCAM regardless of the IOS software release. So, TCAM utilization depends on the ACL configuration. It also depends on the order of configuring each ACL; TCAM utilization may differ if one ACL is configured before another and vice versa. Copying the same ACL configuration to the running-config may also cause TCAM utilization to change.

**Note**

TCAM resources are not consumed when the interface is in a down state.

TCAM utilization on Supervisors II-Plus-TS, IV, V, and the Catalyst 4948 switch may be optimized depending on the ACL configuration and IOS software version. For instance, Cisco IOS Release 12.2(31)SGA and later releases automatically reorder order-independent ACL entries to preserve masks. Two ACEs are order-independent if a single packet can match only one of them. For example, the following two ACEs are order-independent:

```
permit ip host 10.1.1.10 any
permit ip host 10.1.1.20 any
```

Any packet that would match the first ACE would not match the second, and vice versa. In contrast, the following two ACEs are not order-independent:

```
permit ip host 10.1.1.10 any
permit ip any host 10.1.1.20
```

A packet with source IP address 10.1.1.10 and destination IP address 10.1.1.20 would be able to match both ACEs, so their order matters.

When estimating TCAM utilization for Supervisor Engines II-Plus-TS, IV, V, and the Catalyst 4948 switch prior to deployment, start with the default configuration. Because of the dynamic nature of programming ACEs that share masks, estimating TCAM utilization is unpredictable when ACLs are already programmed.

For Cisco IOS Release 12.2(31)SGA and later, you can estimate TCAM utilization for IP ACL provided the TCAM is empty. For each IP ACL, four ACEs are automatically added to the ACL: two static ACEs, an appended IP deny-all ACE, and an appended permit-all ACE. So, the minimum number of masks for an IP ACL is five. To find the number of masks utilized by the remaining ACEs, count the number of different masks, adding one for every different mask with more than eight ACEs.

For Supervisor Engines II-Plus-TS, IV, V, and the Catalyst 4948 switch running IOS software prior to release 12.2(31)SGA, ACLs are not automatically optimized before the TCAM is programmed. Grouping ACEs with similar masks prior to configuring the ACL may improve mask utilization.

**Note**

After upgrading to Cisco IOS Release 12.2(31)SGA or later on Supervisor Engines II-Plus-TS, IV, V, and the Catalyst 4948 switch, TCAM ACL utilization may decrease because of independent ACE reordering. Conversely, downgrading to Cisco IOS Release 12.2(31)SG or earlier may cause TCAM utilization to increase.

TCAM Programming Algorithms

**Note**

The TCAM programming algorithm is *NOT* available on Supervisor Engine 6-E.

Beginning with Cisco IOS Release 12.2(25)EWA, two TCAM programming algorithms are supported on Catalyst 4500 and 4900 series switches: packed and scattered. The *packed* mode algorithm programs the entries in the same 8-entry TCAM block provided the entries' masks match. If the current entry's mask differs from previous entries', the switch software programs the entry in a new 8-entry block. If the mask does not change, or if the mask changes every eight entries across ACLs from the beginning to the end of the configuration, the TCAM may be fully utilized in packed mode for Supervisor Engines II-Plus-TS, IV, V, and the Catalyst 4948 series switch.

In *scattered* mode, a single ACL's entries are distributed across different 8-entry blocks until the ACL is fully programmed. If successive ACLs have the same mask pattern as the first ACL, the TCAM on Supervisor Engines II-Plus-TS, IV, V, and the Catalyst 4948 series switch may be fully utilized.

Scattered mode is recommended for IP Source Guard configurations on Supervisor Engines II-Plus-TS, IV, V, and the Catalyst 4948 switch. This is because the mask pattern for per-VLAN ACLs is the same for all ports configured for IP Source Guard: permit ARP packets, permit Layer 2 traffic if port security is not configured, permit IP traffic from a particular source IP address with a 32-bit mask, deny unknown, and permit all.

**Note**

The TCAM programming algorithm can be configured on Supervisor Engine V-10GE and the Catalyst 4948-10GE switch running Cisco IOS Release 12.2(25)EWA or its subsequent maintenance releases. On Supervisor Engine V-10GE and the Catalyst 4948-10GE switch, however, because ACL masks are not shared among ACEs, TCAM utilization will be the same regardless of the programming algorithm is configured.

**Note**

The TCAM programming algorithm cannot be configured on Supervisor Engines II-Plus-10GE or V-10GE or the Catalyst 4948-10GE switch running Cisco IOS Release 12.2(25)SG and later.

**Note**

The TCAM utilization should not change after you successively configure the same TCAM programming algorithm. For example, configuring access-list hardware entries packed twice should not affect TCAM utilization. However, TCAM utilization may change if one or more commands are issued between successive configurations of the same TCAM programming algorithm.

Below is a summary of scenarios that cause TCAM utilization to change:

- Addition or deletion of ACLs or ACEs in the running-config
- Copying or recopying the ACL configuration from bootflash, a TFTP server, or compact flash memory to the running-config
- Changing the TCAM programming algorithm
- Saving the running-config to NVRAM and reloading the switch
- Resizing the feature ACL or QoS regions of the TCAM with the **access-list hardware region <feature | qos> <input | output> balance <percent>** command on Cisco IOS Release 12.2(31)SGA and beyond.
- Upgrading from images based on Cisco IOS Release 12.2(25)EWA to images based on Cisco IOS Release 12.2(31)SGA

As discussed earlier, two types of hardware resources are consumed when you program ACLs: entries and masks. If either one of these resources is exhausted, no additional ACLs can be programmed into hardware.

If you run out of resources, you refer to the following sections:

- [Change the Programming Algorithm, page 43-9](#)
- [Resize the TCAM Regions, page 43-10](#)
- [Selecting Mode of Capturing Control Packets, page 43-12](#)

Change the Programming Algorithm

If the masks on a system are exhausted, but entries are available, changing the programming scheme from packed to scattered might free up masks, allowing additional ACLs to be programmed into hardware.



Note

Changing the ACL programming algorithm or resizing the TCAM regions causes all ACLs to be temporarily unloaded from the hardware and then reloaded in accordance with the new TCAM parameters. ACLs are inoperative until the reloading process is complete.

The goal is to use TCAM resources more efficiently by minimizing the number of masks per ACL entry.

To...	Use the Command...
Compare TCAM utilization when employing the scattered or packed algorithms.	Switch# show platform hardware acl statistics utilization brief
Change the algorithm from packed to scattered.	Switch(config)# access-list hardware entries scattered
Change the algorithm from scattered to packed.	Switch(config)# access-list hardware entries packed



Note

access-list hardware entries packed is the default, which do *not* appear in the output of the **show running-config** command. If you configure scattered mode, the line “access-list hardware entries scattered” will appear in the output. Instead, if you configure packed mode, *nothing* will appear in the output.



Note

The default TCAM programming algorithm is packed.

The following output was collected from a switch running in packed mode. Observe that 89 percent of the masks are required to program only 49 percent of the ACL entries.

```
Switch# configure terminal
Enter configuration commands, one per line. End with CNTL/Z.
Switch(config)# access-list hardware entries packed
Switch(config)# end
Switch#
01:15:34: %SYS-5-CONFIG_I: Configured from console by console
Switch#
Switch# show platform hardware acl statistics utilization brief
```

	Entries/Total (%)	Masks/Total (%)
Input Acl (PortAndVlan)	2016 / 4096 (49)	460 / 512 (89)
Input Acl (PortOrVlan)	6 / 4096 (0)	4 / 512 (0)
Input Qos (PortAndVlan)	0 / 4096 (0)	0 / 512 (0)
Input Qos (PortOrVlan)	0 / 4096 (0)	0 / 512 (0)
Output Acl (PortAndVlan)	0 / 4096 (0)	0 / 512 (0)
Output Acl (PortOrVlan)	0 / 4096 (0)	0 / 512 (0)
Output Qos (PortAndVlan)	0 / 4096 (0)	0 / 512 (0)
Output Qos (PortOrVlan)	0 / 4096 (0)	0 / 512 (0)

```
L4Ops: used 2 out of 64
```

The following output was collected after the algorithm was switched to scattered. Observe that the number of masks required to program 49 percent of the entries has decreased to 49 percent.

**Note**

When you enable DHCP snooping and IP Source Guard on all ports on a chassis, you must use the scattered keyword.

```
Switch# configure terminal
Enter configuration commands, one per line. End with CNTL/Z.
Switch(config)# access-list hardware entries scattered
Switch(config)# end
Switch#
01:39:37: %SYS-5-CONFIG_I: Configured from console by console
Switch#
Switch# show platform hardware acl statistics utilization brief
Entries/Total(%)  Masks/Total(%)
-----
Input  Acl(PortAndVlan)  2016 / 4096 ( 49)  252 / 512 ( 49)
Input  Acl(PortOrVlan)   6 / 4096 ( 0)    5 / 512 ( 0)
Input  Qos(PortAndVlan)  0 / 4096 ( 0)    0 / 512 ( 0)
Input  Qos(PortOrVlan)  0 / 4096 ( 0)    0 / 512 ( 0)
Output Acl(PortAndVlan)  0 / 4096 ( 0)    0 / 512 ( 0)
Output Acl(PortOrVlan)  0 / 4096 ( 0)    0 / 512 ( 0)
Output Qos(PortAndVlan)  0 / 4096 ( 0)    0 / 512 ( 0)
Output Qos(PortOrVlan)  0 / 4096 ( 0)    0 / 512 ( 0)
```

```
L4Ops: used 2 out of 64
```

```
Switch#
```

Resize the TCAM Regions

The TCAM is divided into regions, each of which holds different kinds of entries. There are four main TCAM types: Input ACL, Output ACL, Input QoS, and Output QoS. Each is divided into a PortAndVlan region and a PortOrVlan region. By default the PortAndVlan region and PortOrVlan region are of equal size.

The following table lists the entries and mask counts for each of the supported supervisor engines. The entry/mask counts for the various supervisor engines are for each TCAM type; for example, the input feature TCAM has 16,000 entries, and the output feature TCAM has 16,000 entries.

Supervisor Engine	Entries	Masks
Supervisor Engine III	16,000	2,000
Supervisor Engine IV	16,000	2,000
Supervisor Engine V	16,000	2,000
Supervisor Engine II-Plus	8,000	1,000
Supervisor Engine II-Plus-TS	8,000	1,000
Supervisor Engine V-10GE	16,000	16,000
Supervisor Engine II-Plus-10GE	TBP	TBP

**Note**

Because of the ratio of entries to masks on Supervisor Engines II-Plus-TS, IV, V, and the Catalyst 4948 switch is 8:1, TCAM space for masks may be exhausted before space for entries is exhausted.

**Note**

One region in a TCAM type might be filled while the other region still has free space. When this happens, the regions can be resized to move the free entries from the region where they are not needed to the region where they are needed. Regions are resized using the **access-list hardware region {feature | qos} {input | output} balance** command. Each TCAM type has its own independent region balance.

**Note**

Higher balance values indicate more entries to the PortAndVlan region and less entries to the PortOrVlan region. Lower balance values indicate less entries to the PortAndVlan region and more entries to the PortOrVlan region. A balance of 50 indicates equal allocation to both PortAndVlan and PortOrVlan regions.

**Note**

You can only shift entries between the PortAndVlan region and the PortOrVlan region for a specific TCAM type (for example, from the Input ACL TCAM PortOrVlan region to the Input ACL TCAM PortAndVlan region). You cannot shift entries between TCAM types.

To determine whether region resizing would be beneficial, use the **show platform hardware acl statistics utilization brief** command:

```
Switch# show platform hardware acl statistics utilization brief

Input  Acl(PortAndVlan)      2346 / 8112 ( 29)      1014 / 1014 (100)
Input  Acl(PortOrVlan)       0 / 8112 ( 0)          0 / 1014 ( 0)
Input  Qos(PortOrVlan)      0 / 8128 ( 0)          0 / 1016 ( 0)
Input  Qos(PortOrVlan)      0 / 8128 ( 0)          0 / 1016 ( 0)
Output Acl(PortOrVlan)     0 / 8112 ( 0)          0 / 1014 ( 0)
Output Acl(PortOrVlan)     0 / 8112 ( 0)          0 / 1014 ( 0)
Output Qos(PortOrVlan)     0 / 8128 ( 0)          0 / 1016 ( 0)
Output Qos(PortOrVlan)     0 / 8128 ( 0)          0 / 1016 ( 0)
```

L4Ops: used 2 out of 64

The above output indicates that the Input ACL PortAndVlan region is out of masks, but there is free space in the Input ACL PortOrVlan region that could be repurposed. The following example shows how to change the region balance of the Input ACL TCAM so that 75 per cent of the entries are allocated to the PortAndVlan region and only 25 per cent to the PortOrVlan region.

```
Switch# configure terminal
Switch(config)# access-list hardware region feature input balance 75
```

After adjusting the region balance, the PortAndVlan region has more resources allocated to it, and the PortOrVlan region has fewer resources.

```
Switch# show platform hardware acl statistics utilization brief

Input  Acl(PortAndVlan)      2346 / 12160 ( 19)      1014 / 1520 ( 67)
Input  Acl(PortOrVlan)       0 / 4064 ( 0)          0 / 508 ( 0)
Input  Qos(PortOrVlan)      0 / 8128 ( 0)          0 / 1016 ( 0)
Input  Qos(PortOrVlan)      0 / 8128 ( 0)          0 / 1016 ( 0)
```

```

Output Acl (PortOrVlan)      0 / 8112 ( 0)      0 / 1014 ( 0)
Output Acl (PortOrVlan)      0 / 8112 ( 0)      0 / 1014 ( 0)
Output Qos (PortOrVlan)      0 / 8128 ( 0)      0 / 1016 ( 0)
Output Qos (PortOrVlan)      0 / 8128 ( 0)      0 / 1016 ( 0)

```

```

L4Ops: used 2 out of 64
Switch#

```

**Note**

The **no** form of the **access-list hardware region {feature | qos} {input | output} balance** command or a balance of 50 forces the configuration to the default values. A similar configuration can also be performed for QoS.

Troubleshooting High CPU Due to ACLs

Packets that match entries in fully programmed ACLs are processed in hardware. However, large ACL and IPSG configurations may exhaust TCAM masks on Supervisor Engines II-Plus-TS, IV, V, and the Catalyst 4948 switch before the ACLs are fully programmed.

Packets that match entries in partially programmed ACLs are processed in software using the CPU. This may cause high CPU utilization and packets to be dropped. To determine whether packets are being dropped due to high CPU utilization, reference the following:

http://www.cisco.com/en/US/products/hw/switches/ps663/products_tech_note09186a00804cef15.shtml

If the ACL and/or IPSG configuration is partially programmed in hardware, upgrading to Cisco IOS Release 12.2(31)SGA or later and resizing the TCAM regions may enable the ACLs to be fully programmed.

**Note**

Removal of obsolete TCAM entries may take several CPU process review cycles to complete. This may cause some packets to be switched in software if the TCAM entry or mask utilization is at or near 100%.

Selecting Mode of Capturing Control Packets

In some deployments, you might want to bridge control packets in hardware rather than globally capture and forwarding them in software (at the expense of the CPU). The per-VLAN capture mode feature allowing a Catalyst 4500 series switch to capture control packets only on selected VLANs and bridge traffic in hardware on all other VLANs.

When you employ per-VLAN capture mode on your switch, it partially disables the global TCAM capture entries internally and attaches feature-specific capture ACLs on those VLANs that are enabled for snooping or routing features. (All IP capture entries, CGMP, and other non-IP entries are still captured through global TCAM.) Because this feature controls specific control packets, they are captured only on the VLANs on which the internal ACLs are installed. On all other VLANs, the control traffic is bridged in hardware rather than forwarded to CPU.

The per-VLAN capture mode allows you to apply user-defined ACLs and QoS policers (in hardware) on control packets. Furthermore, you can subject the aggregate control traffic ingressing the CPU to Control Plane Policing.

When you use per-VLAN capture mode, the following four protocol groups are selectable per VLAN. Observe the breakdown of protocols intercepted by each group.

- IGMP Snooping - Cgmp, Ospf, Igmp, RipV2, Pim, 224.0.0.1, 224.0.0.2, 224.0.0.*

- DHCP Snooping - Client to Server, Server to Client, Server to Server
- Unicast Routing - Ospf, Rip v2, 224.0.0.1, 224.0.0.2, 224.0.0.*
- Multicast Routing - Ospf, Rip v2, Icmp, Pim, 224.0.0.1, 224.0.0.2, 224.0.0.*

Because some of the groups have multiple overlapping ACEs (for example, 224.0.0.* is present in all the groups except for DHCP Snooping), turning on a certain group will also trigger the interception of some protocols from other groups.

Following are the programming triggers for the four protocol groups per VLAN:

- IGMP Snooping should be enabled globally on a given VLAN.
- DHCP Snooping should be enabled globally on a given VLAN.
- Unicast Routing should be enabled and SVI (or a Layer 3 physical) interface should be up and configured with an IP protocol address. This is because interfaces immediately become part of the routing process once the SVI interface comes up and the protocol family address is configured.
- Multicast Routing should be enabled and one of the multicast routing protocols should be configured on the interface (IGMP, PIMv1, PIMv2, MBGP, MOSPF, DVMRP, and IGMP snooping).

Caveats and Restriction



Note

Before configuring per-VLAN capture mode, you should examine your configuration to ensure that only the necessary features are enabled on the desired VLANs.

The following caveats and restrictions apply to per-VLAN capture mode:

- Enabling per-VLAN capture mode consumes additional entries in the ACL/feature TCAM.
The number of available TCAM entries depends on the type of supervisor engine. The entry/mask count further limits the utilization of the ACL/feature TCAM.
- Certain configurations can exhaust TCAM resource earlier in per-VLAN capture mode than in global capture mode (such as, IP Source Guard is enabled on several interfaces, or on a user configured PAFL).

You can re-size TCAM regions to make more entries available to the PortAndVlan or PortOrVlan region based on the configuration. This allows more entries to be programmed in hardware before reaching the limit. When TCAM resources are exhausted, the packets are forwarded in software.

- In per-VLAN capture mode, you can configure ACLs to permit or deny control traffic on a VLAN or port.

Because security ACLs are terminated by an *implicit deny*, you must ensure that the ACLs are configured to permit the control packets necessary for the feature (protocol) to operate. However, this rule does not differ from the default behavior.

Configuration

To select the mode of capturing control packets, perform this task:

	Command	Purpose
Step 1	Switch# conf terminal	Enter configuration mode.
Step 2	Switch(config)# [no] access-list hardware capture mode [vlan global]	Select mode of capturing control packets. The no form of the access-list hardware capture mode command restores the capture mode to the default, global.
Step 3	Switch(config)# end	Return to enable mode.

This example shows how to configure a Catalyst 4500 series switch to capture control packets only on VLANs where features are enabled:

```
Switch# configure terminal
Enter configuration commands, one per line. End with CNTL/Z.
Switch(config)# access-list hardware capture mode vlan
Switch(config)# end
Switch#
```

This example shows how to configure a Catalyst 4500 series switch to capture control packets globally across all VLANs (using *static ACL*, the default mode):

```
Switch# configure terminal
Enter configuration commands, one per line. End with CNTL/Z.
Switch(config)# access-list hardware capture mode global
Switch(config)# end
Switch#
```

When the capture mode changes from global to VLAN mode, the static CAM entries are invalidated. This creates a window during which control packets may pass through a Catalyst 4500 series switch without being intercepted to the CPU. This temporary situation is restored as soon as the new per-VLAN capture entries are programmed in the hardware.

Once you configure per-VLAN capture mode, you should examine the show commands for individual features to verify the appropriate behavior. In per-VLAN capture mode, the invalidated static CAM entries will appear as inactive in the output of the **show platform hardware acl input entries static** command. For example, the hit count for inactive entries will remain frozen because those entries are invalidated and applied per VLAN where the feature is enabled:

CamIndex	Entry Type	Active	Hit Count	CamRegion
50	PermitSharedStp	Y	3344	ControlPktsTwo
51	PermitLoopbackTest	Y	0	ControlPktsTwo
52	PermitProtTunnel	Y	0	ControlPktsTwo
53	CaptureCgmp	N	440	ControlPktsTwo
54	CaptureOspf	N	4321	ControlPktsTwo
55	CaptureIcmp	N	0	ControlPktsTwo

TCAM Programming and ACLs for Supervisor Engine 6-E

You apply three types of hardware resources when you program ACLs and ACL-based features on the Supervisor Engine 6-E: mapping table entries (MTEs), profiles, and TCAM value/mask entries. If any of these resources are exhausted, packets are sent to the CPU for software-based processing.

**Note**

Unlike the Supervisor Engine II-Plus through V-10GE, the Supervisor Engine 6-E automatically manages the available resources. Because masks are not shared on the Supervisor Engine 6-E, there is only one programming algorithm. Because there are no regions, there is no need for region resizing.

If you exhaust resources on the Supervisor Engine 6-E, you should try reducing the complexity of your configuration.

**Note**

TCAM resources are not consumed when the interface is in a down state.

Layer 4 Operators in ACLs

The following sections describe guidelines and restrictions for configuring ACLs that include Layer 4 port operations:

- [Restrictions for Layer 4 Operations, page 43-15](#)
- [Configuration Guidelines for Layer 4 Operations, page 43-16](#)
- [How ACL Processing Impacts CPU, page 43-17](#)

Restrictions for Layer 4 Operations

You can specify these operator types, each of which uses one Layer 4 operation in the hardware:

- gt (greater than)
- lt (less than)
- neq (not equal)
- range (inclusive range)

For Supervisor Engine 2-Plus to V-10GE, you should not specify more than six different operations on the same ACL. If you exceed this number, each new operation might cause the affected ACE (access control entry) to be translated into multiple ACEs in hardware. If you exceed this number, the affected ACE might be processed in software.

For Supervisor Engine 6-E, the limits on the number of Layer 4 operations differ for each type of ACL, and can also vary based on other factors: whether an ACL is applied to incoming or outgoing traffic, whether the ACL is a security ACL or is used as a match condition for a QoS policy, and whether IPv6 ACLs are being programmed using the compressed flowlabel format.

**Note**

The IPv6 compressed flowlabel format uses the Layer 2 Address Table to compress a portion of the IPv6 source address of each ACE in the ACL. The extra space freed in the flowlabel can then be used to support more Layer 4 operations. For this compression to be used, the IPv6 ACL cannot contain any ACEs which mask in only a portion of the bottom 48 bits of the source IPv6 address.

Generally, you will receive at most the following number of Layer 4 operations on the same ACL:

Direction	Protocol	Type	Operations
Input	IPv4	Security	16
Input	IPv6 Compressed	Security	16
Input	IPv6 Uncompressed	Security	7
Input	IPv4	QoS	5
Input	IPv6 Compressed	QoS	12
Input	IPv6 Uncompressed	QoS	8
Output	IPv4	Security	17
Output	IPv6 Compressed	Security	17
Output	IPv6 Uncompressed	Security	8
Output	IPv4	QoS	5
Output	IPv6 Compressed	QoS	12
Output	IPv6 Uncompressed	QoS	8

**Note**

Cases where up to 16 Operations are supported; the 17th will trigger an expansion.

If you exceed the number of available Layer 4 operations, each new operation might cause the affected ACE to be translated into multiple ACEs in the hardware. If this translation fails, packets are sent to the CPU for software processing.

Configuration Guidelines for Layer 4 Operations

Keep the following guidelines in mind when using Layer 4 operators:

- Layer 4 operations are considered different if the operator or operand differ. For example, the following ACL contains three different Layer 4 operations because `gt 10` and `gt 11` are considered two different Layer 4 operations:

```
... gt 10 permit
... lt 9 deny
... gt 11 deny
```

**Note**

The `eq` operator can be used an unlimited number of times because `eq` does not use a Layer 4 operation in hardware.

- Layer 4 operations are considered different if the same operator/operand couple applies once to a source port and once to a destination port, as in the following example:

```
... Src gt 10...
... Dst gt 10
```

A more detailed example follows:

```
access-list 101
... (dst port) gt 10 permit
... (dst port) lt 9 deny
... (dst port) gt 11 deny
```

```

... (dst port) neq 6 permit
... (src port) neq 6 deny
... (dst port) gt 10 deny

access-list 102
... (dst port) gt 20 deny
... (src port) lt 9 deny
... (src port) range 11 13 deny
... (dst port) neq 6 permit

```

Access lists 101 and 102 use the following Layer 4 operations:

- Access list 101 Layer 4 operations: 5
 - gt 10 permit and gt 10 deny both use the same operation because they are identical and both operate on the destination port.
- Access list 102 Layer 4 operations: 4
- Total Layer 4 operations: 8 (due to sharing between the two access lists)
 - neq6 permit is shared between the two ACLs because they are identical and both operate on the same destination port.
- A description of the Layer 4 operations usage is as follows:
 - Layer 4 operation 1 stores gt 10 permit and gt 10 deny from ACL 101
 - Layer 4 operation 2 stores lt 9 deny from ACL 101
 - Layer 4 operation 3 stores gt 11 deny from ACL 101
 - Layer 4 operation 4 stores neg 6 permit from ACL 101 and 102
 - Layer 4 operation 5 stores neg 6 deny from ACL 101
 - Layer 4 operation 6 stores gt 20 deny from ACL 102
 - Layer 4 operation 7 stores lt 9 deny from ACL 102
 - Layer 4 operation 8 stores range 11 13 deny from ACL 102

How ACL Processing Impacts CPU

ACL processing can impact the CPU in two ways:

- For some packets, when the hardware runs out of resources, the software must perform the ACL matches:
 - TCP flag combinations other than “rst ack” and “syn fin rst,” “urq,” and “psh” are processed in hardware. “rst ack” is equivalent to the keyword **established**. Other TCP flag combinations are supported in software.
 - For *Supervisor Engine 2-Plus to V-10GE*, you can specify up to six Layer 4 operations (lt, gt, neq, and range) in an ACL in order for all operations to be guaranteed to be processed in hardware. More than six Layer 4 operations trigger an attempt to translate the excess operations into multiple ACEs in hardware. If this attempt fails, packets are processed in software. The translation process is less likely to succeed on large ACLs with a great number of Layer 4 operations, and on switches with large numbers of ACLs configured. The precise limit depends on how many other ACLs are configured and which specific Layer 4 operations are used by the ACLs being translated. The eq operator does not require any Layer 4 operations and can be used any number of times.

- For *Supervisor Engine 6-E*, refer to the “Restrictions for Layer 4 Operations” section on page 43-15.
- If the total number of Layer 4 operations in an ACL is less than six, you can distribute the operations in any way you choose.

Examples:

The following access lists are processed completely in hardware:

```
access-list 104 permit tcp any any established
access-list 105 permit tcp any any rst ack
access-list 107 permit tcp any synfin rst
```

Access lists 104 and 105 are identical; established is shorthand for rst and ack.

Access list 101, below, is processed completely in software:

```
access-list 101 permit tcp any any syn
```

Because four source and two destination operations exist, access list 106, below, is processed in hardware:

```
access-list 106 permit tcp any range 100 120 any range 120 140
access-list 106 permit tcp any range 140 160 any range 180 200
access-list 106 permit tcp any range 200 220
access-list 106 deny tcp any range 220 240
```

In the following code, the Layer 4 operations for the third ACE trigger an attempt to translate dst lt 1023 into multiple ACEs in hardware, because three source and three destination operations exist. If the translation attempt fails, the third ACE is processed in software.

```
access-list 102 permit tcp any lt 80 any gt 100
access-list 102 permit tcp any range 100 120 any range 120 1024
access-list 102 permit tcp any gt 1024 any lt 1023
```

Similarly, for access list 103, below, the third ACE triggers an attempt to translate dst gt 1023 into multiple ACEs in hardware. If the attempt fails, the third ACE is processed in software. Although the operations for source and destination ports look similar, they are considered different Layer 4 operations.)

```
access-list 103 permit tcp any lt 80 any lt 80
access-list 103 permit tcp any range 100 120 any range 100 120
access-list 103 permit tcp any gt 1024 any gt 1023
```



Note Remember that source port lt 80 and destination port lt 80 are considered different operations.

- Some packets must be sent to the CPU for accounting purposes, but the action is still performed by the hardware. For example, if a packet must be logged, a copy is sent to the CPU for logging, but the forwarding (or dropping) is performed in the hardware. Although logging slows the CPU, it does not affect the forwarding rate. This sequence of events would happen under the following conditions:
 - When a log keyword is used
 - When an output ACL denies a packet
 - When an input ACL denies a packet, and on the interface where the ACL is applied, **ip unreachable** is enabled (**ip unreachable** is enabled by default on all the interfaces)

Configuring Unicast MAC Address Filtering

To block all unicast traffic to or from a MAC address in a specified VLAN, perform this task:

Command	Purpose
Switch(config)# mac-address-table static <i>mac_address</i> vlan <i>vlan_ID</i> drop	Blocks all traffic to or from the configured unicast MAC address in the specified VLAN. To clear MAC address-based blocking, use the no form of this command without the drop keyword.

This example shows how to block all unicast traffic to or from MAC address 0050.3e8d.6400 in VLAN 12:

```
Router# configure terminal
Router(config)# mac-address-table static 0050.3e8d.6400 vlan 12 drop
```

Configuring Named MAC Extended ACLs



Note

This section applies to Supervisor Engines II-Plus to 6-E.

You can filter non-IP traffic on a VLAN and on a physical Layer 2 port by using MAC addresses and named MAC extended ACLs. The procedure is similar to that of configuring other extended named ACLs. You can use a number to name the access list, but MAC access list numbers from 700 to 799 are not supported.



Note

Named MAC extended ACLs cannot be applied to Layer 3 interfaces.

For more information about the supported non-IP protocols in the **mac access-list extended** command, refer to the *Catalyst 4500 Series Switch Cisco IOS Command Reference*.

To create a named MAC extended ACL, perform this task:

	Command	Purpose
Step 1	Switch# configure terminal	Enters global configuration mode.
Step 2	Switch(config)# mac access-list extended <i>name</i>	Defines an extended MAC access list using a name.

	Command	Purpose
Step 3	Switch(config-ext-macl)# {deny permit} {any host source MAC address / source MAC address mask} {any host destination MAC address / destination MAC address mask} [protocol-family {appletalk arp-non-ipv4 decnet ipx ipv6 rarp-ipv4 rarp-non-ipv4 vines xns}]	In extended MAC access-list configuration mode, specify to permit or deny any source MAC address, a source MAC address with a mask, or a specific host source MAC address and any destination MAC address, destination MAC address with a mask, or a specific destination MAC address. (Optional) <ul style="list-style-type: none"> [protocol-family {appletalk arp-non-ipv4 decnet ipx ipv6 rarp-ipv4 rarp-non-ipv4 vines xns}] <p>Note On Supervisor Engine 6-E, IPv6 packets do <i>not</i> generate Layer 2 ACL lookup keys, and thus do not match on MAC ACLs in the same way that IPv4 packets would not match against MAC ACLs in Supervisor Engines II-Plus to V-10GE. Therefore, the ipv6 keyword is applicable to MAC ACLs on Supervisor Engines II-Plus to V-10GE, but not on Supervisor Engine 6-E.</p>
Step 4	Switch(config-ext-macl)# end	Returns to privileged EXEC mode.
Step 5	Switch# show access-lists [number name]	Shows the access list configuration.
Step 6	Switch(config)# copy running-config startup-config	(Optional) Saves your entries in the configuration file.

You can use the **no mac access-list extended name** global configuration command to delete the entire ACL. You can also delete individual ACEs from named MAC extended ACLs.

This example shows how to create and display an access list named mac1, denying only EtherType DECnet Phase IV traffic, but permitting all other types of traffic:

```
Switch(config)# mac access-list extended mac1
Switch(config-ext-macl)# deny any any decnet-iv (old) protocol-family decnet (new)
Switch(config-ext-macl)# permit any any
Switch(config-ext-macl)# end
Switch # show access-lists
Extended MAC access list mac1
    deny any any decnet-iv (old) protocol-family decnet (new)
    permit any any
```

To enable or disable hardware statistics, enter the following commands while configuring ACEs in the access list:

```
Switch# config t
Enter configuration commands, one per line. End with CNTL/Z.
Switch(config)# mac access-list extended mac1
Switch(config-ext-nacl)# hardware statistics
Switch(config-ext-nacl)# end
```

Configuring Named IPv6 ACLs



Note

This section applies to Supervisor Engine 6-E.

Supervisor 6E also support hardware based IPv6 Acl to filter unicast, multicast, and broadcast Ipv6 traffic on Layer 3 interface. Such access list can only be configured on I3 interface which has ipv6 address configured.

To create a named IPv6 ACLs, perform this task:

	Command	Purpose
Step 1	Switch# configure terminal	Enters global configuration mode.
Step 2	Switch(config)# ipv6 access-list name	Defines an IPv6 access list using a name.
Step 3	Switch(config-ipv6-acl)# { deny permit } { any proto } { host ipv6-addr ipv6-prefix } host ipv6-addr ipv6-prefix }	Specifies each IPv6 ACE Note This step may be repeated to define multiple ACEs in the ACL.
Step 4	Switch(config-ipv6-acl)# hardware statistics	(Optional) Enables hardware statistics for the IPv6 ACL.
Step 5	Switch(config-ipv6-acl)# end	Returns to privileged EXEC mode.
Step 6	Switch# show ipv6 access-list	Display the IPv6 access list configuration.

You can use the **no ipv6 access-list name** global configuration command to delete the IPv6 ACL. You can also delete individual ACEs from IPv6 access-list.

The following example shows how to create and display an IPv6 access list named *v6test*, denying only one ipv6 traffic with one particular source/destination address, but permitting all other types of ipv6 traffic:

```
Switch(config)# ipv6 access-list v6test
Switch(config-ipv6-acl)# deny ipv6 host 2020::10 host 2040::10
Switch(config-ipv6-acl)# permit any any
Switch(config-ipv6-acl)# end
Switch# show ipv6 access-list
IPv6 access list v6test
  deny ipv6 host 2020::10 host 2040::10 sequence 10
  permit ipv6 any any sequence 20
```

To enable hardware statistics, enter the following commands while configuring the access list ACE:

```
Switch(config)# ipv6 access-list v6test
Switch(config-ipv6-acl)# hardware statistics
Switch(config-ipv6-acl)# end
```



Note *Hardware statistics* is disabled by default.

Applying IPv6 ACLs to a Layer 3 Interface

To apply an IPv6 ACL to a Layer 3 interface, perform the following task:

	Command	Purpose
Step 1	Switch# configure terminal	Enters global configuration mode.

	Command	Purpose
Step 2	Switch(config)# interface <i>interface-type</i> <i>slot/interface</i>	Specifies the interface to be configured. Note <i>interface-type</i> must be a Layer 3 interface.
Step 3	Switch(config-if)# ipv6 traffic-filter <i>ipv6-acl</i> { in out }	Apply the ipv6 ACL to a Layer 3 interface.



Note IPv6 ACLs are only supported in hardware on Supervisor VI-E.



Note IPv6 ACLs are only supported on Layer 3 interfaces.

The following example applies the extended-named IPv6 ACL *simple-ipv6-acl* to SVI 300 routed ingress traffic:

```
Switch# configure terminal
Switch(config)# interface vlan 300
Switch(config-if)# ipv6 traffic-filter simple-ipv6-acl in
```

Configuring VLAN Maps

This section contains the following subsections:

- [VLAN Map Configuration Guidelines, page 43-23](#)
- [Creating and Deleting VLAN Maps, page 43-23](#)
- [Applying a VLAN Map to a VLAN, page 43-26](#)
- [Using VLAN Maps in Your Network, page 43-26](#)

This section describes how to configure VLAN maps, which is the only way to control filtering within a VLAN. VLAN maps have no direction. To filter traffic in a specific direction by using a VLAN map, you need to include an ACL with specific source or destination addresses. If there is a match clause for that type of packet (IP or MAC) in the VLAN map, the default action is to drop the packet if the packet does not match any of the entries within the map. If there is no match clause for that type of packet, the default is to forward the packet.

To create a VLAN map and apply it to one or more VLANs, perform this task:

-
- Step 1** Create the standard or extended IP ACLs or named MAC extended ACLs that you want to apply to the VLAN.
- Step 2** Enter the **vlan access-map** global configuration command to create a VLAN ACL map entry.
- Step 3** In access map configuration mode, you have the optional to enter an **action** (**forward** [the default] or **drop**) and enter the **match** command to specify an IP packet or a non-IP packet and to match the packet against one or more ACLs (standard or extended). If a match clause is not specified, the action is applied to all packets. The match clause can be used to match against multiple ACLs. If a packet matches any of the specified ACLs, the action is applied.

**Note**

If the VLAN map has a match clause for the type of packet (IP or MAC) and the packet does not match the type, the default is to drop the packet. If there is no match clause in the VLAN map for that type of packet, and no action specified, the packet is forwarded.

Step 4 Use the **vlan filter** global configuration command to apply a VLAN map to one or more VLANs.

**Note**

You cannot apply a VLAN map to a VLAN on a switch that has ACLs applied to Layer 2 interfaces (port ACLs).

VLAN Map Configuration Guidelines

Keep the following guidelines in mind when configuring VLAN maps:

- VLAN maps do not filter IPv4 ARP packets.
- If there is no router ACL configured to deny traffic on a routed VLAN interface (input or output), and no VLAN map configured, all traffic is permitted.
- Each VLAN map consists of a series of entries. The order of entries in a VLAN map is important. A packet that comes into the switch is tested against the first entry in the VLAN map. If it matches, the action specified for that part of the VLAN map is taken. If there is no match, the packet is tested against the next entry in the map.
- If the VLAN map has at least one match clause for the type of packet (IP or MAC) and the packet does not match any of these match clauses, the default is to drop the packet. If there is no match clause for that type of packet in the VLAN map, the default is to forward the packet.
- The system might take longer to boot if you have configured a very large number of ACLs.

Creating and Deleting VLAN Maps

Each VLAN map consists of an ordered series of entries. To create, add to, or delete a VLAN map entry, perform this task:

	Command	Purpose
Step 1	Switch# configure terminal	Enters global configuration mode.
Step 2	Switch(config)# vlan access-map <i>name [number]</i>	Creates a VLAN map, and give it a name and (optionally) a number. The number is the sequence number of the entry within the map. When you create VLAN maps with the same name, numbers are assigned sequentially in increments of 10. When modifying or deleting maps, you can enter the number of the map entry that you want to modify or delete. This command enables access-map configuration mode.
Step 3	Switch(config-access-map)# action { drop forward }	(Optional) Sets the action for the map entry. The default is to forward.

	Command	Purpose
Step 4	Switch(config-access-map)# match { ip mac } address { <i>name</i> <i>number</i> } [<i>name</i> <i>number</i>]	Matches the packet (using either the IP or MAC address) against one or more standard or extended access lists. Note that packets are matched only against access lists of the correct protocol type. IP packets are compared with standard or extended IP access lists. Non-IP packets are only compared with named MAC extended access lists. If a match clause is not specified, the action is taken on all packets.
Step 5	Switch(config-access-map)# end	Returns to global configuration mode.
Step 6	Switch(config)# show running-config	Displays the access list configuration.
Step 7	Switch(config)# copy running-config startup-config	(Optional) Saves your entries in the configuration file.

You can use the **no vlan access-map** *name* global configuration command to delete a map. You can use the **no vlan access-map** *name number* global configuration command to delete a single sequence entry from within the map. You can use the **no action** access-map configuration command to enforce the default action, which is to forward.

VLAN maps do not use the specific **permit** or **deny** keywords. To deny a packet by using VLAN maps, create an ACL that would match the packet, and then set the action to drop. A permit in the ACL is the same as a match. A deny in the ACL means no match.

Examples of ACLs and VLAN Maps

These examples show how to create ACLs and VLAN maps that for specific purposes.

Example 1

This example shows how to create an ACL and a VLAN map to deny a packet. In the first map, any packets that match the ip1 ACL (TCP packets) would be dropped. You first create the ip1 ACL to permit any TCP packet and no other packets. Because there is a match clause for IP packets in the VLAN map, the default action is to drop any IP packet that does not match any of the match clauses.

```
Switch(config)# ip access-list extended ip1
Switch(config-ext-nacl)# permit tcp any any
Switch(config-ext-nacl)# exit

Switch(config)# vlan access-map map_1 10
Switch(config-access-map)# match ip address ip1
Switch(config-access-map)# action drop
```

This example shows how to create a VLAN map to permit a packet. ACL ip2 permits UDP packets; and any packets that match the ip2 ACL are forwarded.

```
Switch(config)# ip access-list extended ip2
Switch(config-ext-nacl)# permit udp any any
Switch(config-ext-nacl)# exit
Switch(config)# vlan access-map map_1 20
Switch(config-access-map)# match ip address ip2
Switch(config-access-map)# action forward
```

In this map, any IP packets that did not match any of the previous ACLs (that is, packets that are not TCP packets or UDP packets) would get dropped.

Example 2

In this example, the VLAN map is configured to drop IP packets and to forward MAC packets by default. By applying standard ACL 101 and the extended named access lists **igmp-match** and **tcp-match**, the VLAN map is configured to do the following:

- Forward all UDP packets
- Drop all IGMP packets
- Forward all TCP packets
- Drop all other IP packets
- Forward all non-IP packets

```
Switch(config)# access-list 101 permit udp any any
Switch(config)# ip access-list extended igmp-match
Switch(config-ext-nacl)# permit igmp any any
Switch(config)# ip access-list extended tcp-match
Switch(config-ext-nacl)# permit tcp any any
Switch(config-ext-nacl)# exit
Switch(config)# vlan access-map drop-ip-default 10
Switch(config-access-map)# match ip address 101
Switch(config-access-map)# action forward
Switch(config-access-map)# exit
Switch(config)# vlan access-map drop-ip-default 20
Switch(config-access-map)# match ip address igmp-match
Switch(config-access-map)# action drop
Switch(config-access-map)# exit
Switch(config)# vlan access-map drop-ip-default 30
Switch(config-access-map)# match ip address tcp-match
Switch(config-access-map)# action forward
```

Example 3

In this example, the VLAN map is configured to drop MAC packets and forward IP packets by default. By applying MAC extended access lists, **good-hosts** and **good-protocols**, the VLAN map is configured to do the following:

- Forward MAC packets from hosts 0000.0c00.0111 and 0000.0c00.0211
- Forward MAC packets of DECnet or VINES (Virtual Integrated Network Service) protocol-family
- Drop all other non-IP packets
- Forward all IP packets

```
Switch(config)# mac access-list extended good-hosts
Switch(config-ext-macl)# permit host 000.0c00.0111 any
Switch(config-ext-macl)# permit host 000.0c00.0211 any
Switch(config-ext-nacl)# exit
Switch(config)# mac access-list extended good-protocols
Switch(config-ext-macl)# permit any any protocol-family decnet
Switch(config-ext-macl)# permit any any protocol-family vines
Switch(config-ext-nacl)# exit
Switch(config)# vlan access-map drop-mac-default 10
Switch(config-access-map)# match mac address good-hosts
Switch(config-access-map)# action forward
Switch(config-access-map)# exit
Switch(config)# vlan access-map drop-mac-default 20
Switch(config-access-map)# match mac address good-protocols
Switch(config-access-map)# action forward
```

Example 4

In this example, the VLAN map is configured to drop all packets (IP and non-IP). By applying access lists **tcp-match** and **good-hosts**, the VLAN map is configured to do the following:

- Forward all TCP packets
- Forward MAC packets from hosts 0000.0c00.0111 and 0000.0c00.0211
- Drop all other IP packets
- Drop all other MAC packets

```
Switch(config)# vlan access-map drop-all-default 10
Switch(config-access-map)# match ip address tcp-match
Switch(config-access-map)# action forward
Switch(config-access-map)# exit
Switch(config)# vlan access-map drop-all-default 20
Switch(config-access-map)# match mac address good-hosts
Switch(config-access-map)# action forward
```

Applying a VLAN Map to a VLAN

To apply a VLAN map to one or more VLANs, perform this task:

	Command	Purpose
Step 1	Switch# configure terminal	Enters global configuration mode.
Step 2	Switch(config)# vlan filter <i>mapname</i> vlan-list <i>list</i>	Applies the VLAN map to one or more VLAN IDs. The list can be a single VLAN ID (22), a consecutive list (10-22), or a string of VLAN IDs (12, 22, 30). Spaces around comma, and dash, are optional.
Step 3	Switch(config)# show running-config	Displays the access list configuration.
Step 4	Switch(config)# copy running-config startup-config	(Optional) Saves your entries in the configuration file.

**Note**

You cannot apply a VLAN map to a VLAN on a switch that has ACLs applied to Layer 2 interfaces (port ACLs).

This example shows how to apply VLAN map 1 to VLANs 20 through 22:

```
Switch(config)# vlan filter map 1 vlan-list 20-22
```

Using VLAN Maps in Your Network

Figure 43-3 shows a typical wiring closet configuration. Host X and Host Y are in different VLANs, connected to wiring closet switches A and C. Traffic moving from Host X to Host Y is routed by Switch B. Access to traffic moving from Host X to Host Y can be controlled at the entry point of Switch A. In the following configuration, the switch can support a VLAN map and a QoS classification ACL.

Figure 43-3 Wiring Closet Configuration

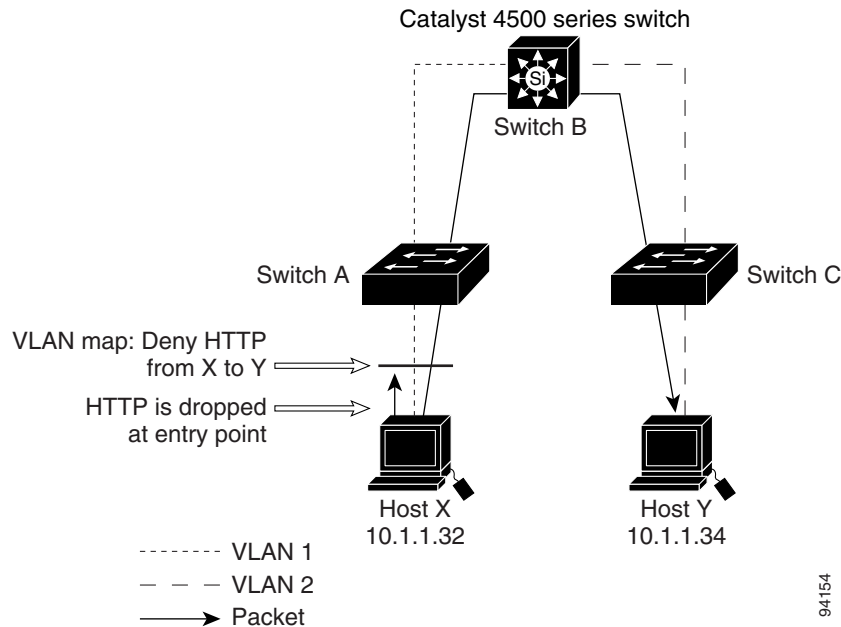

For example, if you do not want HTTP traffic to be switched from Host X to Host Y, you could apply a VLAN map on Switch A to drop all HTTP traffic moving from Host X (IP address 10.1.1.32) to Host Y (IP address 10.1.1.34) at Switch A and not bridge the traffic to Switch B. To configure this scenario, you would do the following:

First, define an IP access list `http` to permit (match) any TCP traffic on the HTTP port, as follows:

```
Switch(config)# ip access-list extended http
Switch(config-ext-nacl)# permit tcp host 10.1.1.32 host 10.1.1.34 eq www
Switch(config-ext-nacl)# exit
```

Next, create a VLAN access map named `map2` so that traffic that matches the `http` access list is dropped and all other IP traffic is forwarded, as follows:

```
Switch(config)# vlan access-map map2 10
Switch(config-access-map)# match ip address http
Switch(config-access-map)# action drop
Switch(config-access-map)# exit

Switch(config)# ip access-list extended match_all
Switch(config-ext-nacl)# permit ip any any
Switch(config-ext-nacl)# exit
Switch(config)# vlan access-map map2 20
Switch(config-access-map)# match ip address match_all
Switch(config-access-map)# action forward
```

Then, apply the VLAN access map named `map2` to VLAN 1, as follows:

```
Switch(config)# vlan filter map2 vlan 1
```

Denying Access to a Server on Another VLAN

Figure 43-4 shows how to restrict access to a server on another VLAN. In this example, server 10.1.1.100 in VLAN 10 has the following access restrictions:

- Hosts in subnet 10.1.2.0/8 in VLAN 20 should not have access.
- Hosts 10.1.1.4 and 10.1.1.8 in VLAN 10 should not have access.

Figure 43-4 Deny Access to a Server on Another VLAN

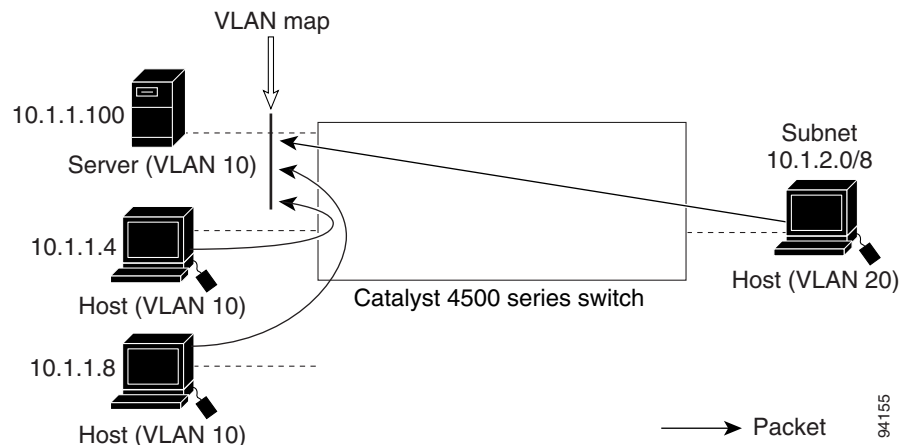

This procedure configures ACLs with VLAN maps to deny access to a server on another VLAN. The VLAN map SERVER1_ACL denies access to hosts in subnet 10.1.2.0/8, host 10.1.1.4, and host 10.1.1.8. Then it permits all other IP traffic. In Step 3, VLAN map SERVER1 is applied to VLAN 10.

To configure this scenario, you could take the following steps:

Step 1 Define the IP ACL to match and permit the correct packets.

```
Switch(config)# ip access-list extended SERVER1_ACL
Switch(config-ext-nacl)# permit ip 10.1.2.0 0.0.0.255 host 10.1.1.100
Switch(config-ext-nacl)# permit ip host 10.1.1.4 host 10.1.1.100
Switch(config-ext-nacl)# permit ip host 10.1.1.8 host 10.1.1.100
Switch(config-ext-nacl)# exit
```

Step 2 Define a VLAN map using the ACL to drop IP packets that match SERVER1_ACL and forward IP packets that do not match the ACL.

```
Switch(config)# vlan access-map SERVER1_MAP
Switch(config-access-map)# match ip address SERVER1_ACL
Switch(config-access-map)# action drop
Switch(config)# vlan access-map SERVER1_MAP 20
Switch(config-access-map)# action forward
Switch(config-access-map)# exit
```

Step 3 Apply the VLAN map to VLAN 10.

```
Switch(config)# vlan filter SERVER1_MAP vlan-list 10.
```

Displaying VLAN Access Map Information

To display information about VLAN access maps or VLAN filters, perform one of these tasks.

Command	Purpose
Switch# show vlan access-map [<i>mapname</i>]	Show information about all VLAN access-maps or the specified access map.
Switch# show vlan filter [access-map <i>name</i> / vlan <i>vlan-id</i>]	Show information about all VLAN filters or about a specified VLAN or VLAN access map.

This is a sample output of the **show vlan access-map** command:

```
Switch# show vlan access-map
Vlan access-map "map_1" 10
  Match clauses:
    ip address: ip1
  Action:
    drop
Vlan access-map "map_1" 20
  Match clauses:
    mac address: mac1
  Action:
    forward
Vlan access-map "map_1" 30
  Match clauses:
  Action:
    drop
```



Note

Sequence 30 does not have a match clause. All packets (IP as well as non-IP) are matched against it and dropped.

This is a sample output of the **show vlan filter** command:

```
Switch# show vlan filter
VLAN Map map_1 is filtering VLANs:
  20-22
```

Using VLAN Maps with Router ACLs

If the VLAN map has a match clause for a packet type (IP or MAC) and the packet does not match the type, the default is to drop the packet. If there is no match clause in the VLAN map, and no action is specified, the packet is forwarded if it does not match any VLAN map entry.



Note

You cannot combine VLAN maps or input router ACLs with port ACLs on a switch.

Guidelines for Using Router ACLs and VLAN Maps

Use these guidelines when you need to use a router ACL and a VLAN map on the same VLAN.

Because the switch hardware performs one lookup for each direction (input and output), you must merge a router ACL and a VLAN map when they are configured on the same VLAN. Merging the router ACL with the VLAN map can significantly increase the number of ACEs.

When possible, try to write the ACL so that all entries have a single action except for the final, default action. You should write the ACL using one of these two forms:

```
permit...
permit...
permit...
deny ip any any
```

or

```
deny...
deny...
deny...
permit ip any any
```

To define multiple permit or deny actions in an ACL, group each action type together to reduce the number of entries.

If you need to specify the full-flow mode and the ACL contains both IP ACEs and TCP/UDP/ICMP ACEs with Layer 4 information, put the Layer 4 ACEs at the end of the list. Doing this gives priority to the filtering of traffic based on IP addresses.

Examples of Router ACLs and VLAN Maps Applied to VLANs

These examples show how router ACLs and VLAN maps are applied on a VLAN to control the access of switched, bridged, routed, and multicast packets. Although the following illustrations show packets being forwarded to their destination, each time a packet crosses a line indicating a VLAN map or an ACL, the packet could be dropped rather than forwarded.

ACLs and Switched Packets

Figure 43-5 shows how an ACL processes packets that are switched within a VLAN. Packets switched within the VLAN are not processed by router ACLs.

Figure 43-5 Applying ACLs on Switched Packets

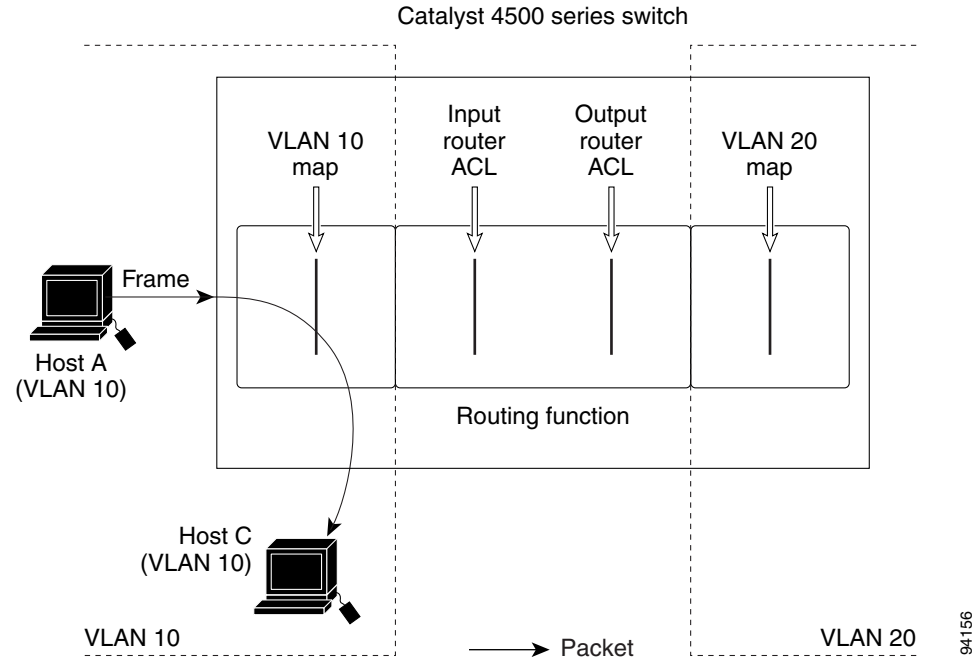

ACLs and Routed Packets

Figure 43-6 shows how ACLs are applied on routed packets. For routed packets, the ACLs are applied in this order:

1. VLAN map for input VLAN
2. Input router ACL
3. Output router ACL
4. VLAN map for output VLAN

Figure 43-6 Applying ACLs on Routed Packets

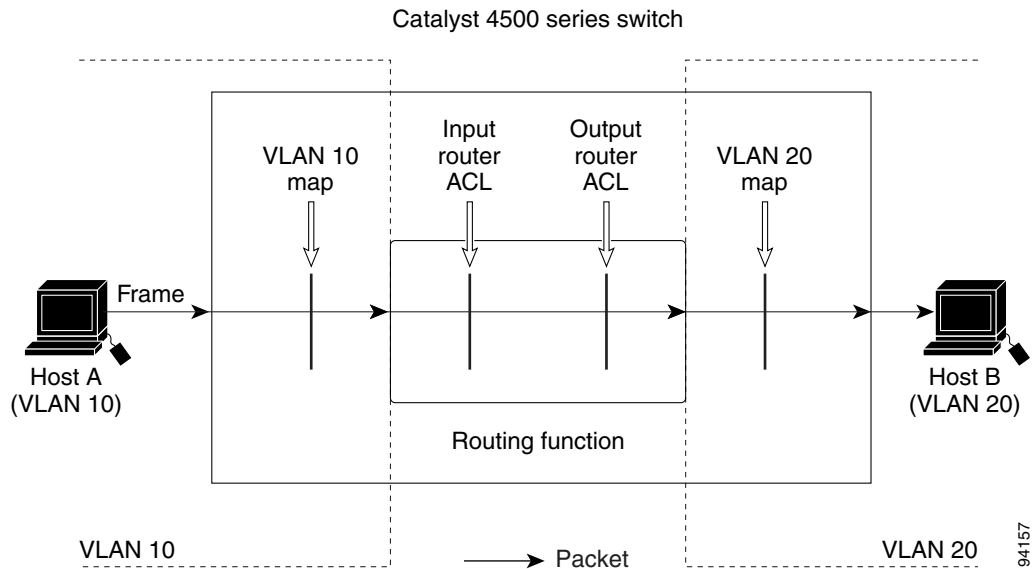

Configuring PACLS

This section describes how to configure PACLS, which are used to control filtering on Layer 2 interfaces. PACLS can filter traffic to or from Layer 2 interfaces based on Layer 3 information, Layer 4 head information or non-IP Layer 2 information.

This section contains the following topics:

- [Creating a PACL, page 43-32](#)
- [PACL Configuration Guidelines, page 43-33](#)
- [Configuring IP and MAC ACLs on a Layer 2 Interface, page 43-33](#)
- [Using PACL with Access-Group Mode, page 43-34](#)
- [Configuring Access-group Mode on Layer 2 Interface, page 43-34](#)
- [Applying ACLs to a Layer 2 Interface, page 43-35](#)
- [Displaying an ACL Configuration on a Layer 2 Interface, page 43-35](#)

Creating a PACL

To create a PACL and apply it to one or more interfaces, perform this task:

-
- Step 1** Create the standard or extended IP ACLs or named MAC extended ACLs that you want to apply to the interface.
- Step 2** Use the `ip access-group` or `mac access-group interface` command to apply a IP ACL or MAC ACL to one or more Layer 2 interfaces.
-

PACL Configuration Guidelines

Consider the following guidelines when configuring PACLs:

- There can be at most one IP access list and MAC access list applied to the same Layer 2 interface per direction.
- The IP access list filters only IP packets, whereas the MAC access list filters only non-IP packets.
- The number of ACLs and ACEs that can be configured as part of a PACL are bounded by the hardware resources on the switch. Those hardware resources are shared by various ACL features (for example, RACL, VACL) that are configured on the system. If there are insufficient hardware resources to program PACL in hardware, the actions for input and output PACLs differ:
 - For input PACLs, some packets are sent to CPU for software forwarding.
 - For output PACLs, the PACL is disabled on the port.
- These restrictions pertain to output PACLs only:
 - If there are insufficient hardware resources to program the PACL, the output PACL is not applied to the port, and you receive a warning message.
 - If an output PACL is configured on a Layer 2 port, then neither a VACL nor a Router ACL can be configured on the VLANs to which the Layer 2 port belongs.

If any VACL or Router ACL is configured on the VLANs to which the Layer 2 port belongs, the output PACL cannot be configured on the Layer 2 port. That is, PACLs and VLAN-based ACLs (VACL and Router ACL) are mutually exclusive on Layer 2 ports.
- The input IP ACL logging option is supported, although logging is not supported for output IP ACLs, and MAC ACLs.
- The access group mode can change the way PACLs interact with other ACLs. To maintain consistent behavior across Cisco platforms, use the default access group mode.

Configuring IP and MAC ACLs on a Layer 2 Interface

Only IP or MAC ACLs can be applied to Layer 2 physical interfaces. Standard (numbered, named) and Extended (numbered, named) IP ACLs, and Extended Named MAC ACLs are also supported.

To apply IP or MAC ACLs on a Layer 2 interface, perform this task:

	Command	Purpose
Step 1	Switch# configure t	Enters global configuration mode.
Step 2	Switch(config)# interface <i>interface</i>	Enters interface config mode.
Step 3	Switch(config-if)# [no] {ip mac} } access-group {name number in out}	Applies numbered or named ACL to the Layer 2 interface. The NO prefix deletes the IP or MAC ACL from the Layer 2 interface.
Step 4	Switch(config)# show running-config	Displays the access list configuration.

The following example shows how to configure the Extended Named IP ACL `simple-ip-acl` to permit all TCP traffic and implicitly deny all other IP traffic:

```
Switch(config)# ip access-list extended simple-ip-acl
Switch(config-ext-nacl)# permit tcp any any
Switch(config-ext-nacl)# end
```

The following example shows how to configure the Extended Named MACL `simple-mac-acl` to permit source host 000.000.011 to any destination host:

```
Switch(config)# mac access-list extended simple-mac-acl
Switch(config-ext-macl)# permit host 000.000.011 any
Switch(config-ext-macl)# end
```

Using PACL with Access-Group Mode

You can use the access group mode to change the way PACLS interact with other ACLs. For example, if a Layer 2 interface belongs to VLAN100, VACL (VLAN filter) V1 is applied on VLAN100, and PACL P1 is applied on the Layer 2 interface. In this situation, you must specify how P1 and V1 impact the traffic with the Layer 2 interface on VLAN100. In a per-interface fashion, the **access-group mode** command can be used to specify one of the desired behaviors that are defined below.

The following modes are defined:

- **prefer port mode**—If PACL is configured on a Layer 2 interface, then PACL takes effect and overwrites the effect of other ACLs (Router ACL and VACL). If no PACL feature is configured on the Layer 2 interface, other features applicable to the interface are merged and applied on the interface. This is the default access group mode.
- **prefer vlan mode**—VLAN-based ACL features take effect on the port provided they have been applied on the port and no PACLS are in effect. If no VLAN-based ACL features are applicable to the Layer 2 interface, then the PACL feature already on the interface is applied.
- **merge mode**—Merges applicable ACL features before they are programmed into the hardware.



Note

Because output PACLS are mutually exclusive with VACL and Router ACLs, the access group mode does not change the behavior of output traffic filtering.

Configuring Access-group Mode on Layer 2 Interface

To configure an access mode on a Layer 2 interface, perform this task:

	Command	Purpose
Step 1	Switch# configure t	Enters global configuration mode.
Step 2	Switch(config)# interface <i>interface</i>	Enters interface config mode.
Step 3	Switch(config-if)# [no] access-group mode { prefer { port vlan } merge }	Applies numbered or named ACL to the Layer 2 interface. The no prefix deletes the IP or MAC ACL from the Layer 2 interface.
Step 4	Switch(config)# show running-config	Displays the access list configuration.

This example shows how to merge and apply features other than PACL on the interface:

```
Switch# configure t
Switch(config)# interface interface
Switch(config-if)# access-group mode prefer port
```

This example shows how to merge applicable ACL features before they are programmed into hardware:

```
Switch# configure t
Switch(config)# interface interface
Switch(config-if)# access-group mode merge
```

Applying ACLs to a Layer 2 Interface

To apply IP and MAC ACLs to a Layer 2 interface, perform one of these tasks:

Command	Purpose
Switch(config-if)# ip access-group ip-acl {in out}	Applies an IP ACL to the Layer 2 interface
Switch(config-if)# mac access-group mac-acl {in out}	Applies a MAC ACL to the Layer 2 interface.



Note

Supervisor Engines III and Supervisor Engine IV running on a Catalyst 4500 series switch support both input and output PACLs on an interface.

This example applies the extended named IP ACL simple-ip-acl to interface FastEthernet 6/1 ingress traffic:

```
Switch# configure t
Switch(config)# interface fastEthernet 6/1
Switch(config-if)# ip access-group simple-ip-acl in
```

This example applies the extended named MAC ACL simple-mac-acl to interface FastEthernet 6/1 egress traffic:

```
Switch# configure t
Switch(config)# interface fastEthernet 6/1
Switch(config-if)# mac access-group simple-mac-acl out
```

Displaying an ACL Configuration on a Layer 2 Interface

To display information about an ACL configuration on Layer 2 interfaces, perform one of these tasks:

Command	Purpose
Switch# show ip interface [interface-name]	Shows the IP access group configuration on the interface.
Switch# show mac access-group interface [interface-name]	Shows the MAC access group configuration on the interface.
Switch# show access-group mode interface [interface-name]	Shows the access group mode configuration on the interface.

This example shows that the IP access group `simple-ip-acl` is configured on the inbound direction of interface `fa6/1`:

```
Switch# show ip interface fast 6/1
FastEthernet6/1 is up, line protocol is up
  Inbound access list is simple-ip-acl
  Outgoing access list is not set
```

This example shows that MAC access group `simple-mac-acl` is configured on the inbound direction of interface `fa6/1`:

```
Switch# show mac access-group interface fast 6/1
Interface FastEthernet6/1:
  Inbound access-list is simple-mac-acl
  Outbound access-list is not set
```

This example shows that access group merge is configured on interface `fa6/1`:

```
Switch# show access-group mode interface fast 6/1
Interface FastEthernet6/1:
  Access group mode is: merge
```

Using PACL with VLAN Maps and Router ACLs

For output PACLs, there is no interaction with VACL or output Router ACLs. (See the restrictions listed in the [“PACL Configuration Guidelines”](#) section on page 43-33.) For input PACLs, however, the interaction with Router ACLs and VACLs depends on the interface access group mode as shown in [Table 43-1](#).

Table 43-1 Interaction Between PACLs, VACLs and Router ACLs

ACL Type(s)	Input PACL		
	prefer port mode	prefer vlan mode	merge mode
1. Input Router ACL	PACL applied	Input Router ACL applied	PACL, Input Router ACL (merged) applied in order (ingress)
2. VACL	PACL applied	VACL applied	PACL, VACL (merged) applied in order (ingress)
3. VACL + Input Router ACL	PACL applied	VACL + Input Router ACL applied	PACL, VACL, Input Router ACL (merged) applied in order (ingress)

Each ACL Type listed in [Table 43-1](#) is synonymous with a different scenario, as explained in the following discussion.

Scenario 1: Host A is connected to an interface in VLAN 20, which has an SVI configured. The interface has input PACL configured, and the SVI has input Router ACL configured as shown in Figure 43-7:

Figure 43-7 Scenario 1: PACL Interaction with an Input Router ACL

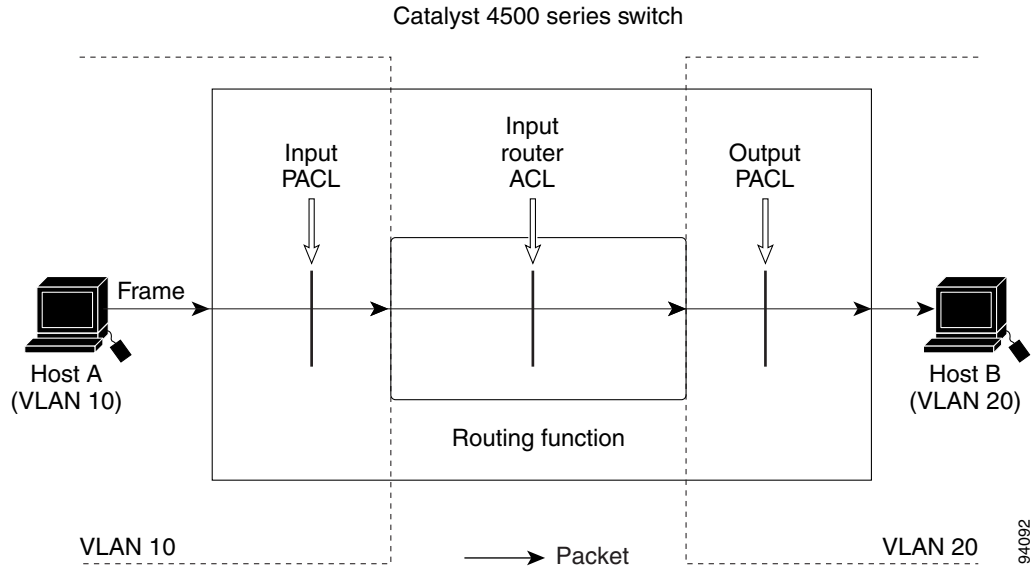

If the interface access group mode is prefer port, then only the input PACL is applied on the ingress traffic from Host A. If the mode is prefer vlan, then only the input Router ACL is applied to ingress traffic from Host A that requires routing. If the mode is merge, then the input PACL is first applied to the ingress traffic from Host A, and the input Router ACL is applied on the traffic that requires routing.

Scenario 2: Host A is connected to an interface in VLAN 10, which has a VACL (VLAN Map) configured and an input PACL configured as shown in Figure 43-8:

Figure 43-8 Scenario 2: PACL Interaction with a VACL

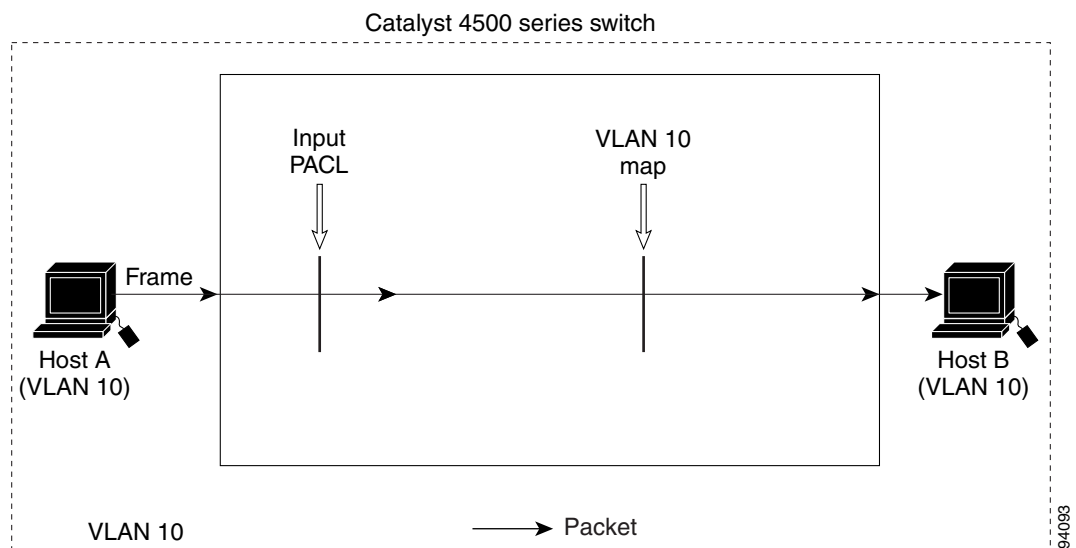

If the interface access group mode is prefer port, then only the input PACL is applied on the ingress traffic from Host A. If the mode is prefer vlan, then only the VACL is applied to the ingress traffic from Host A. If the mode is merge, the input PACL is first applied to the ingress traffic from Host A, and the VACL is applied on the traffic.

Scenario 3: Host A is connected to an interface in VLAN 10, which has a VACL and an SVI configured. The SVI has an input Router ACL configured and the interface has an input PACL configured, as shown in Figure 43-9:

Figure 43-9 Scenario 3: VACL and Input Router ACL

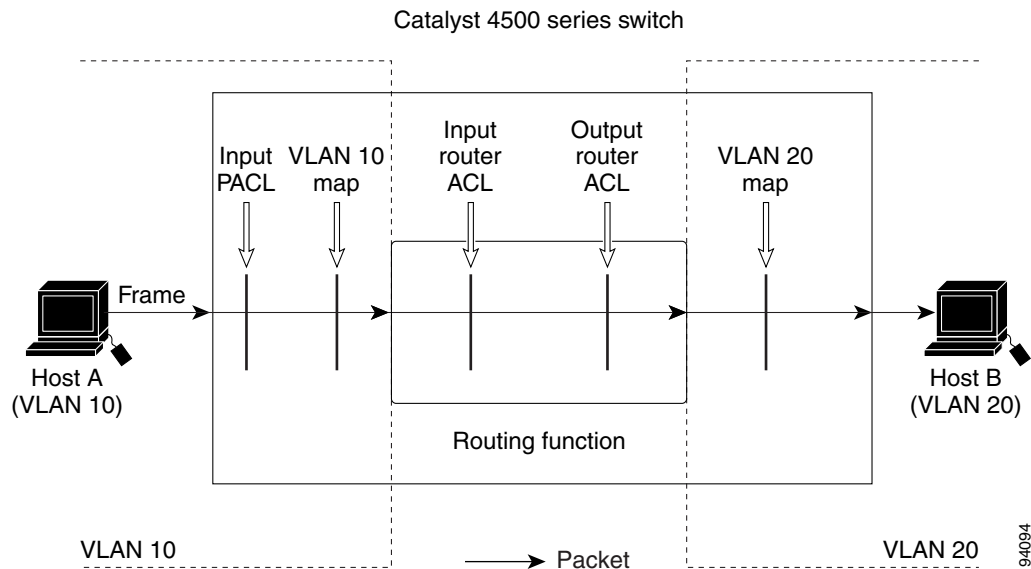

If the interface access group mode is prefer port, then only the input PACL is applied on the ingress traffic from Host A. If the mode is prefer vlan, then the merged results of the VACL and the input Router ACL are applied to the ingress traffic from Host A. If the mode is merge, the input PACL is first applied to the ingress traffic from Host A, the VACL is applied on the traffic and finally, and the input Router ACL is applied to the traffic that needs routing. (that is, the merged results of the input PACL, VACL, and input Router ACL are applied to the traffic).