

Configuring Layer 3 Interfaces

This chapter describes the Layer 3 interfaces on a Catalyst 4500 series switch. It also provides guidelines, procedures, and configuration examples.

This chapter includes the following major sections:

- [Overview of Layer 3 Interfaces, page 22-1](#)
- [Configuration Guidelines, page 22-3](#)
- [Configuring Logical Layer 3 VLAN Interfaces, page 22-3](#)
- [Configuring Physical Layer 3 Interfaces, page 22-4](#)

**Note**

For complete syntax and usage information for the switch commands used in this chapter, refer to the *Catalyst 4500 Series Switch Cisco IOS Command Reference* and related publications at <http://www.cisco.com/univercd/cc/td/doc/product/software/ios122/122cgcr/index.htm>

Overview of Layer 3 Interfaces

This section contains the following subsections:

- [Logical Layer 3 VLAN Interfaces, page 22-2](#)
- [Physical Layer 3 Interfaces, page 22-2](#)

The Catalyst 4500 series switch supports Layer 3 interfaces with the Cisco IOS IP and IP routing protocols. Layer 3, the *network* layer, is primarily responsible for the routing of data in packets across logical internetwork paths.

Layer 2, the *data link* layer, contains the protocols that control the *physical* layer (Layer 1) and how data is framed before being transmitted on the medium. The Layer 2 function of filtering and forwarding data in frames between two segments on a LAN is known as *bridging*.

The Catalyst 4500 series switch supports two types of Layer 3 interfaces. The logical Layer 3 VLAN interfaces integrate the functions of routing and bridging. The physical Layer 3 interfaces allow the Catalyst 4500 series switch to be configured like a traditional router.

Logical Layer 3 VLAN Interfaces

The logical Layer 3 VLAN interfaces provide logical routing interfaces to VLANs on Layer 2 switches. A traditional network requires a physical interface from a router to a switch to perform inter-VLAN routing. The Catalyst 4500 series switch supports inter-VLAN routing by integrating the routing and bridging functions on a single Catalyst 4500 series switch.

Figure 22-1 shows how the routing and bridging functions in the three physical devices of the traditional network are performed logically on one Catalyst 4500 series switch.

Figure 22-1 Logical Layer 3 VLAN Interfaces for the Catalyst 4500 Series Switch

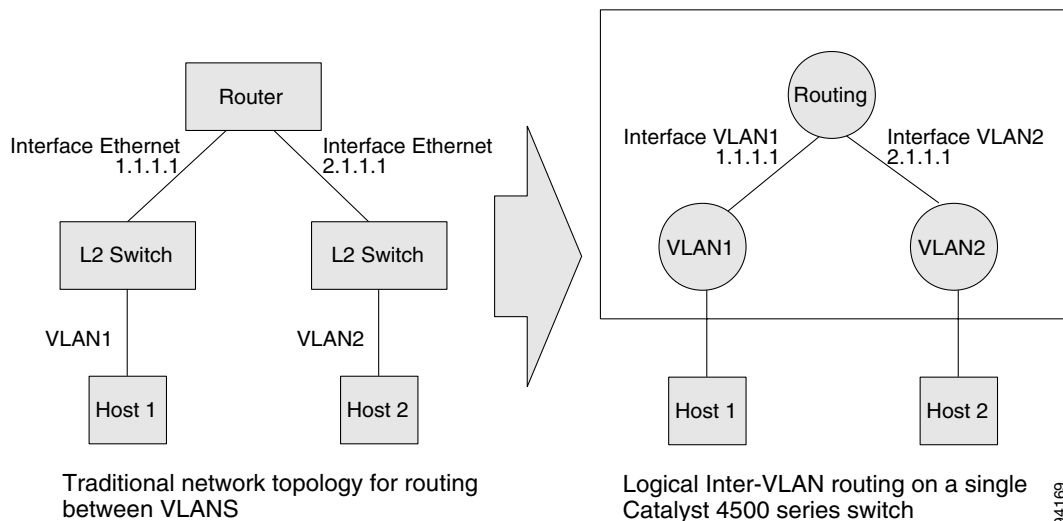

Physical Layer 3 Interfaces

The physical Layer 3 interfaces support capabilities equivalent to a traditional router. These Layer 3 interfaces provide hosts with physical routing interfaces to a Catalyst 4500 series switch.

Figure 22-2 shows how the Catalyst 4500 series switch functions as a traditional router.

Figure 22-2 Physical Layer 3 Interfaces for the Catalyst 4500 Series Switch

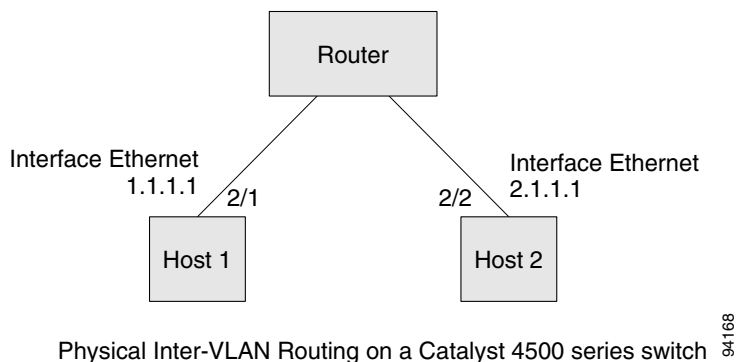

Configuration Guidelines

A Catalyst 4500 series switch supports AppleTalk routing and IPX routing. For AppleTalk routing and IPX routing information, refer to “Configuring AppleTalk” and “Configuring Novell IPX” in the Cisco IOS AppleTalk and Novell IPX Configuration Guide at the following URL:

http://www.cisco.com/univercd/cc/td/doc/product/software/ios122/122cgcr/atipx_c/index.htm

A Catalyst 4500 series switch does not support subinterfaces or the **encapsulation** keyword on Layer 3 Fast Ethernet or Gigabit Ethernet interfaces.



Note

As with any Layer 3 interface running Cisco IOS software, the IP address and network assigned to an SVI cannot overlap those assigned to any other Layer 3 interface on the switch.

Configuring Logical Layer 3 VLAN Interfaces



Note

Before you can configure logical Layer 3 VLAN interfaces, you must create and configure the VLANs on the switch, assign VLAN membership to the Layer 2 interfaces, enable IP routing if IP routing is disabled, and specify an IP routing protocol.

To configure logical Layer 3 VLAN interfaces, perform this task:

	Command	Purpose
Step 1	Switch(config)# vlan <i>vlan_ID</i>	Creates the VLAN.
Step 2	Switch(config)# interface vlan <i>vlan_ID</i>	Selects an interface to configure.
Step 3	Switch(config-if)# ip address <i>ip_address</i> <i>subnet_mask</i>	Configures the IP address and IP subnet.
Step 4	Switch(config-if)# no shutdown	Enables the interface.
Step 5	Switch(config-if)# end	Exits configuration mode.
Step 6	Switch# copy running-config startup-config	Saves your configuration changes to NVRAM.
Step 7	Switch# show interfaces [<i>type slot/interface</i>] Switch# show ip interfaces [<i>type slot/interface</i>] Switch# show running-config interfaces [<i>type slot/interface</i>] Switch# show running-config interfaces vlan <i>vlan_ID</i>	Verifies the configuration.

This example shows how to configure the logical Layer 3 VLAN interface `vlan 2` and assign an IP address:

```
Switch> enable
Switch# config term
Enter configuration commands, one per line. End with CNTL/Z.
Switch(config)# vlan 2
Switch(config)# interface vlan 2
Switch(config-if)# ip address 10.1.1.1 255.255.255.248
Switch(config-if)# no shutdown
Switch(config-if)# end
```

This example uses the **show interfaces** command to display the interface IP address configuration and status of Layer 3 VLAN interface vlan 2:

```
Switch# show interfaces vlan 2
Vlan2 is up, line protocol is down
  Hardware is Ethernet SVI, address is 00D.588F.B604 (bia 00D.588F.B604)
  Internet address is 172.20.52.106/29
  MTU 1500 bytes, BW 1000000 Kbit, DLY 10 usec,
    reliability 255/255, txload 1/255, rxload 1/255
  Encapsulation ARPA, loopback not set
  ARP type: ARPA, ARP Timeout 04:00:00
  Last input never, output never, output hang never
  Last clearing of "show interface" counters never
  Input queue: 0/75/0/0 (size/max/drops/flushes); Total output drops: 0
  Queueing strategy: fifo
  Output queue: 0/40 (size/max)
  5 minute input rate 0 bits/sec, 0 packets/sec
  5 minute output rate 0 bits/sec, 0 packets/sec
    0 packets input, 0 bytes, 0 no buffer
    Received 0 broadcasts, 0 runts, 0 giants, 0 throttles
    0 input errors, 0 CRC, 0 frame, 0 overrun, 0 ignored
    0 packets output, 0 bytes, 0 underruns
    0 output errors, 0 interface resets
    0 output buffer failures, 0 output buffers swapped out
Switch#
```

This example uses the **show running-config** command to display the interface IP address configuration of Layer 3 VLAN interface vlan 2:

```
Switch# show running-config
Building configuration...

Current configuration : !
interface Vlan2
  ip address 10.1.1.1 255.255.255.248
  !
  ip classless
  no ip http server
  !
  !
  line con 0
  line aux 0
  line vty 0 4
  !
end
```

Configuring Physical Layer 3 Interfaces



Note

Before you can configure physical Layer 3 interfaces, you must enable IP routing if IP routing is disabled, and specify an IP routing protocol.

To configure physical Layer 3 interfaces, perform this task:

	Command	Purpose
Step 1	Switch(config)# ip routing	Enables IP routing (Required only if disabled.)
Step 2	Switch(config)# interface {fastethernet gigabitethernet tengigabitethernet} slot/port} {port-channel port_channel_number}	Selects an interface to configure.
Step 3	Switch(config-if)# no switchport	Converts this port from physical Layer 2 port to physical Layer 3 port.
Step 4	Switch(config-if)# ip address ip_address subnet_mask	Configures the IP address and IP subnet.
Step 5	Switch(config-if)# no shutdown	Enables the interface.
Step 6	Switch(config-if)# end	Exits configuration mode.
Step 7	Switch# copy running-config startup-config	Saves your configuration changes to NVRAM.
Step 8	Switch# show interfaces [type slot/interface] Switch# show ip interfaces [type slot/interface] Switch# show running-config interfaces [type slot/interface]	Verifies the configuration.

This example shows how to configure an IP address on Fast Ethernet interface 2/1:

```
Switch# configure terminal
Enter configuration commands, one per line. End with CNTL/Z.
Switch(config)# ip routing
Switch(config)# interface fastethernet 2/1
Switch(config-if)# no switchport
Switch(config-if)# ip address 10.1.1.1 255.255.255.248
Switch(config-if)# no shutdown
Switch(config-if)# end
Switch#
```

This example uses the **show running-config** command to display the interface IP address configuration of Fast Ethernet interface 2/1:

```
Switch# show running-config
Building configuration...
!
interface FastEthernet2/1
  no switchport
  ip address 10.1.1.1 255.255.255.248
!
...
ip classless
no ip http server
!
!
line con 0
line aux 0
line vty 0 4
!
end
```

