

cnfpnctlvc

Configure PNNI Port Control Virtual Channel—PXM45, PXM1E

The **cnfpnctlvc** command lets you configure bandwidth parameters for two types of control channels on a per-port basis. The types of control channels are service-specific connection-oriented protocol (SSCOP) and PNNI routing control channel (PNNI-RCC). The bandwidth parameters are as follows:

- Peak cell rate
- Sustainable cell rate
- Maximum burst size



Note

The default bandwidth parameters for these control VCs comply with ATM Forum standards. You should change the parameters only after very careful consideration of the actual need. The following are possible consequences of changing the control channel bandwidth parameters:

If the bandwidth is reduced too much, the call rate on the port or the PNNI link may significantly drop, or signaling maybe hindered.

If the bandwidth is increased too much, other connections on the port may receive less bandwidth.

Before using **cnfpnctlvc**, note the following:

- You can execute **cnfpnctlvc** for one type of control VC at a time.
- A control VC belongs to a special service type called *virtual switch interface signaling* (VSI-SIG). A VSI-SIG connection behaves like a VBR-nrt connection.
- The port must be down for you to execute **cnfpnctlvc** (so you may first have to use **dnnpport**).
- The bandwidth used by control-type VCs adds to the bandwidth load on the port. Use **dspload** to determine the load on port resources.

The controller protect the flow of control data from bursts in user data by guaranteeing bandwidth for the control VCs. The reserved bandwidth is proportional to the line rate (T3/E3, OC3, OC12, and so on). Also, the excess priority for this category is equal to CBR and is higher than any other category.

The VC for ILMI (when enabled) is also a control channel, but its bandwidth parameters are fixed, as follows: PCR=1000 cps; SCR=50 cps; and MBS=1024 cells. The pertinent ILMI is configured on the AXSM, the PXM1E for its UNI/NNI back card, or the narrowband service modules.

Syntax

```
cnfpnctlvc <portid> <vc-type> [<-pcr> {peak cell rate}] [<-scr> {sustained cell rate}]
[<-mbs> {Maximum burst size}]
```

Syntax Description

<i>portid</i>	<p>The format of the PNNI physical port identifier can vary, as follows:</p> <ul style="list-style-type: none"> On a PXM45: <i>slot:subslot.port:subport</i> “PNNI Format,” in Chapter 1, “Introduction.” On a PXM1E for UNI/NNI back card: <i>slot:subslot.port:subport</i>. On the UNI/NNI back card, the subslot is always 2, but the <i>slot</i> depends on the chassis, as follows: <ul style="list-style-type: none"> In an MGX 8850 chassis, <i>slot</i> is always the logical slot 7. In an MGX 8830 chassis, <i>slot</i> is always the logical slot 1. On a PXM1E for a narrowband service module (NBSM): <i>slot.port</i>. <p>For more details, see the section, “PNNI Format,” in Chapter 1, “Introduction.”</p>
<i>vc-type</i>	The type of control VC. The VC types are pnnircc and sscop .
-pcr	<p>The PCR for the control VC has a range and default that depend on the VC type.</p> <ul style="list-style-type: none"> Range for SSCOP: 1–308000 cps Range for PNNIRCC: 1–5000 cps <p>Defaults:</p> <ul style="list-style-type: none"> If vc-type is pnnircc, the default is 906 cps. If vc-type is sscop, the default is the smaller of either the line rate or the <i>control port rate</i>. The control port rate is fixed at 308000 cps due to a PXM hardware design specification. For example, in the case of an OC3 line (with a line rate of 353207cps), the default PCR is 308000 cps. This relation applies to UNI 3.x and 4.0.
-scr	<p>The SCR of the control VC.</p> <p>Range: 1–5000 cps</p> <p>The default depends first on the VC type and, for SSCOP, the line rate, as follows:</p> <ul style="list-style-type: none"> If vc-type is pnnircc, the default is 453 cps. If vc-type is sscop, the default is computed according to the line rate detected by. For UNI 3.x and 4.0, the defaults are as follows: <ul style="list-style-type: none"> If the line rate is less than 47170 cps, the default is 126 cps If the line rate is 47170–70754 cps, the default is 334 cps If the line rate is 70755–117924 cps, the default is 500 cps If the line rate is 117925–235848 cps, the default is 667 cps If the line rate is 235849–707548 cps, the default is 2000 cps
-mbs	<p>The maximum burst size of the control VC.</p> <p>Range: 1–1000 cells</p> <p>Defaults:</p> <ul style="list-style-type: none"> If vc-type is pnnircc, the default is 171 cells. If vc-type is sscop, the default is 1000 cells.

Related Commands

dsppnctvc (on the active control card), **dspload** (on a service module or the PXM1E)

Attributes

Log: yes State: active Privilege: GROUP1

Example

Change the MBS of the PNN-RCC VC on port 3:1.1:1 to 100 cells. The system returns the error message that the port is still in service. After downing the port with the **dnppnport** command, complete the task. (If connections were on the port, they would go into alarm.) Check the control VCs with **dsppnctlvc**.

One section of the display (labeled “provisioned”) shows *configured* parameters, and one section shows *operational* VC parameters. In this example, the “provisioned” section reflects that you did not configure bandwidth parameters other than MBS, and the “operational” section shows actual bandwidth parameters—including the MBS you configured. Remember to re-activate the port by using **upppnport**.

```
8850_NY.8.PXM.a > cnfpnctlvc 3:1.1:1 sscop -mbs 100

ERROR: Port is not out-of-service

8850_NY.8.PXM.a > dnppnport 3:1.1:1

8850_NY.8.PXM.a > cnfpnctlvc 3:1.1:1 sscop -mbs 100
cnfpnctlvc Successful

8850_NY.7.PXM.a > dsppnctlvc 3:1.1:1

vc type = sscop      Parameter = Provisioned
service category : sig          PCR: Not Provisioned
SCR : Not Provisioned          MBS : 100

vc type = sscop      Parameter = Operational
service category : sig          PCR : 308000
SCR : 2000            MBS : 100

8850_NY.8.PXM.a > upppnport 3:1.1:1
```

cnfpnni-election

Configure PNNI Election—PXM45, PXM1E

The **cnfpnni-election** command lets you specify the priority of a node for the purpose of electing a peer group leader (PGL). By using this ranking, you can promote or prevent certain nodes for consideration for election as PGL.

In a multi-peer group environment, each peer group can elect one PGL. Such an election takes place for every level of the hierarchy. (For example, if three levels exist, three PGL elections occur.) To ensure that a node cannot win the PGL election, you can assign 0 for the priority.

Every node in a peer group runs the election algorithm—with one exception: a node with the Non-Transit for PGL Election Flag set.

In addition to the priority, **cnfpnni-election** lets you specify the following:

- Number of seconds that the node delays advertising its choice of preferred PGL
- Number of seconds that the node waits to be declared the preferred PGL by unanimous agreement among its peer group members
- Number of seconds that the node waits before it restarts the election of a new PGL after connectivity to the current PGL is lost

Syntax

```
cnfpnni-election <node-index> [-priority priority] [-initTime init-time]
[-overrideDelay override-delay] [-reelectionTime reelection-time]
```

Syntax Description

<i>node-index</i>	The <i>node-index</i> uniquely identifies the node within the hierarchy on the local switch. Range: 1–10 Default: 1
-priority	Specify the leadership priority within a peer group. Range: 1–20 Default: 0
-initTime	The number of seconds that this node waits to advertise its choice of preferred PGL. Default: 15 seconds
-overrideDelay	Specify the number of seconds that this PNNI node waits to be declared the preferred PGL by unanimous agreement among its peer group members. Default: 30 seconds
-reelectionTime	After losing connectivity to the current PGL, specify the number of seconds that this node waits before restarting the process of electing a new peer group leader. Default: 15 seconds

Related Commands

dsppnni-election

Attributes

Log: yes State: active Privilege: SUPER_GP

Example

Specify the following PGL election parameters, then use **dsppnni-election** to check these parameters.

- The node index is 1.
- The node election priority is 15.
- The init time is 15 seconds.
- The node waits 20 seconds before proclaiming itself the peer group leader.
- If the node loses connection with the peer group leader for 10 secs it starts the election process.

```
p2spvc4.7.PXM.a > cnfpnni-election 1 -priority 15 -initTime 10 -overrideDelay 20
-reelectionTime 10
```

```
p2spvc4.7.PXM.a > dsppnni-election
```

```
node index: 1
  PGL state.....      OperPgl      Init time(sec).....      10
  Priority.....        15          Override delay(sec)..    20
                                     Re-election time(sec)   10
  Pref PGL.....56:160:47.019181004030211100000000.00107be92f13.01
  PGL.....56:160:47.019181004030211100000000.00107be92f13.01
  Active parent node id..36:56:47.019181004030211100000000.000142265c0d.00
```

```
node index: 2
  PGL state.....      OperPgl      Init time(sec).....      15
  Priority.....        15          Override delay(sec)..    30
                                     Re-election time(sec)   15
  Pref PGL.....36:56:47.019181004030211100000000.000142265c0d.00
  PGL.....36:56:47.019181004030211100000000.000142265c0d.00
  Active parent node id..0:0:00.000000000000000000000000.000000000000.00
```

```
p2spvc4.7.PXM.a >
```

cnfpnni-intf

Configure PNNI Interface—PXM45, PXM1E

The **cnfpnni-intf** command lets you specify two distinct PNNI parameters. The *aggregation token* applies to a logical node, and the *administrative weight (AW)* applies to a port.

Aggregation Tokens

An aggregation token is a marker that indicates which up-links (links going out of the peer group) can be bundled or aggregated at the next logical level. For example, if four links *a*, *b*, *c*, and *d* connect to peer groups X and Y, no aggregation exists for the links by default. The LGNs of these peer groups could have hypothetical names x02 and y02. They would be connected by a single logical link. You could use the **cnfpnni-intf** command to configure aggregation tokens.

If you configure the aggregation token of link *c* as 1, then x02 and y02 would have two logical links. One link would correspond to aggregation token 0, and the other link would correspond to aggregation token 1. In summary:

An aggregation token is the number of links between a peer group leader and the lowest level of a PNNI hierarchy. The range for tokens is 1–32.

Administrative Weight

The administrative weight (AW) is a number that serves as a cost-based determinant of a route. Each port in a PNNI network has a default AW for the egress direction. Whether it uses the default AW or an AW you specify, PNNI adds all the AWs in a prospective route then determines whether the route is too expensive. For an SPVC, you can specify the maximum cost with the **addcon** or **cnfcon** command.

You can specify that *all* classes of service on the port have the same AW, or you can specify an AW for *each service class* on the port. If you specify the same AW for *all*, it overrides the default AW or the AW you might specify for individual services types.

The AW for a path is the sum, in both directions, of the individual weight of each link on the path. See [Usage Guidelines](#) for details about AW.

Syntax

```
cnfpnni-intf <portid>
[-aggregationToken token]
[-awcbr aw]
[-awrtvbr aw]
[-awnrtvbr aw]
[-awabr aw]
[-awubr aw]
[-awall aw]
```

Syntax Description

If you enter **-awall** to specify an AW, it overrides the AW for all individual service types.

<i>portid</i>	<p>The format of the PNNI physical port identifier can vary, as follows:</p> <ul style="list-style-type: none"> On a PXM45: <i>slot:subslot.port:subport</i> On a PXM1E for UNI/NNI back card: <i>slot:subslot.port:subport</i>. On the UNI/NNI back card, the subslot is always 2, but the <i>slot</i> depends on the chassis, as follows: <ul style="list-style-type: none"> In an MGX 8850 chassis, <i>slot</i> is always the logical slot 7. In an MGX 8830 chassis, <i>slot</i> is always the logical slot 1. On a PXM1E for a narrowband service module (NBSM): <i>slot.port</i>. <p>For more details, see the section, “PNNI Format,” in Chapter 1, “Introduction.”</p>
-aggregationToken	<p>Specify a 32-bit number for logical link aggregation between a peer group leader and the lowest level.</p> <p>Range: 0–2147483648 Default: 0</p>
-awcbr	<p>Specify the administrative weight for constant bit rate (CBR) on this interface.</p> <p>Range: 0–4,194,304 Default: 5040</p>
-awrtvbr	<p>Specify the administrative weight for real-time variable bit rate (rt-VBR) on this interface.</p> <p>Range: 0–4,194,304 Default: 5040</p>
-awnrtvbr	<p>Specify the administrative weight for non-real-time variable bit rate (nrt-VBR) on this interface.</p> <p>Range: 0–4,194,304 Default: 5040</p>
-awabr	<p>Specify the administrative weight for available bit rate (ABR) on this interface.</p> <p>Range: 0–4,194,304 Default: 5040</p>
-awubr	<p>Specify the administrative weight for unspecified bit rate (UBR) on this interface. UBR connections can include SVC ping connections.</p> <p>Range: 0–4,194,304 Default: 5040</p>
-awall	<p>Specify the administrative weight for all service types on this interface. If you use -awall, this <i>aw</i> becomes the AW for every service type on this port.</p> <p>Range: 0–4,194,304 Default: 5040</p>

Usage Guidelines

PNNI includes a protocol for routing the topology state. This protocol advertises details about the peer group links and nodes. Links and nodes are assigned attributes that can be used to diagnose and tune network behavior.

The administrative weight (AW) for a port is an integer that has no units of measure. The switch compares the sum of all AWs along a path with the sum of all AWs along another path to determine which path is more cost-effective. You can specify one AW for all classes of service, or you can specify an AW for each class of service. The AW for all (**-awall**) overrides the AW for an individual class.

The AW parameter influences how PNNI selects a path within a peer group and therefore how it distributes SVCs and SPVCs. PNNI route selection can also use AW to exclude certain links from routing. For example, it can define a backup link for use only when insufficient bandwidth is available on the primary link.

Related Commands

dsppnni-intf

Attributes

Log: yes State: active Privilege: SUPER_GP

Example

Specify the following AWs on port 4:1.1:11.

- The AW for real time variable bit rate is 11040.
- The AW for non-real time variable bit rate is 20040.
- The AW for unspecified bit rate is 1040.

Use the **dsppnni-intf** command to display the configuration.

```
SanJose.7.PXM.a > cnfpnni-intf 4:1.1:11 -awrtvbr 11040 -awnrtvbr 20040 -awubr 1040
```

```
SanJose.7.PXM.a > dsppnni-intf 4:1.1:11
```

```
Physical port id: 4: 1.1:11                      Logical port id: 17045515
  Aggr token.....                                      0                      AW-NRTVBR.....                      20040
  AW-CBR.....                                              5040                      AW-ABR.....                              5040
  AW-RTVBR.....                                              11040                      AW-UBR.....                              1040
```

```
SanJose.7.PXM.a >
```

cnfpnni-link-selection

Configure PNNI Link Selection—PXM45, PXM1E

The **cnfpnni-link-selection** command specifies which routing policies are used to select one of the parallel links that connect a neighboring PNNI node. “Neighboring node” in this case means a directly connected node. The **cnfpnni-link-selection** command applies only if parallel links exist between the specified port and neighboring nodes.

Syntax

```
cnfpnni-link-selection <portid> {minaw | maxavcr | maxcr | loadbalance}
```

Syntax Description

<i>portid</i>	<p>The format of the PNNI physical port identifier can vary, as follows:</p> <ul style="list-style-type: none"> On a PXM45: <i>slot:subslot.port:subport</i> On a PXM1E for UNI/NNI back card: <i>slot:subslot.port:subport</i>. On the UNI/NNI back card, the subslot is always 2, but the <i>slot</i> depends on the chassis, as follows: <ul style="list-style-type: none"> In an MGX 8850 chassis, <i>slot</i> is always the logical slot 7. In an MGX 8830 chassis, <i>slot</i> is always the logical slot 1. On a PXM1E for a narrowband service module (NBSM): <i>slot.port</i>. <p>For more details, see the section, “PNNI Format,” in Chapter 1, “Introduction.”</p>
<i>minaw</i>	<p>The routing protocol selects the link with the least administrative weight (AW). The AW is a numeric value that every logical port ingress has. The total cost of a route is the sum of all ingress port AWs in both directions of the route.</p> <p>The <i>minaw</i> policy is the default.</p>
<i>maxavcr</i>	<p>The routing protocol selects the link with the largest available cell rate (AvCR). The AvCR is the remaining bandwidth after the total utilized bandwidth is subtracted from the maximum cell rate (MaxCR).</p> <p>The <i>maxavcr</i> policy works well for traffic that consistently requires a large amount of bandwidth.</p>
<i>maxcr</i>	<p>The routing protocol selects the link with the largest maximum cell rate (MaxCR). Typically, the MaxCR is the maximum speed of the line (or trunk). Therefore, if one link traverses an OC3 line and another link traverses a T3 line, the MaxCR policy dictates that PNNI select the OC3 line. Only when sufficient bandwidth does not exist on a line does the routing protocol switch to AvCR.</p> <p>The <i>maxcr</i> policy works well for bursty traffic.</p>
<i>loadbalance</i>	<p>The routing protocol alternates the link it selects for routing new calls and so evenly distributes the number of calls across the parallel links. The load balance policy works well with links that have identical or very similar AW or bandwidth characteristics.</p>

Related Commands

dsppnni-link-selection

Attributes

Log: yes State: active Privilege: SUPER_GP

Example

Specify maximum available cell rate as the routing policy for the link with port ID 4:1.1:11. Use **dsppnni-link-selection** to see the link selection policy on this port. Note that **dsppnni-link-selection** shows the logical port number for the physical port ID.

```
SanJose.7.PXM.a > cnfpnni-link-selection 4:1.1:11 maxavcr

SanJose.7.PXM.a > dsppnni-link-selection 4:1.1:11

physical port id:      4:1.1:11      link selection: maxavcr
logical port id:      17045515

SanJose.7.PXM.a >
```

cnfpnni-mtu

Configure PNNI Maximum Transfer Unit—PXM45, PXM1E

The **cnfpnni-mtu** command specifies the maximum data packet size in number of bytes. This command is useful for internetworking compatibility, for which you must match the maximum packet size of your peer group to a size that another peer group can handle. This command is primarily for configuring internetwork compatibility, but you can use it in lab trials to test the affect of various packet sizes on the performance of the peer group.

Use **dsppnni-mtu** to display the PNNI packet size configuration.

Syntax

```
cnfpnni-mtu <mtu>
```

Syntax Description

<i>mtu</i>	Specify maximum transmit unit in number of bytes. Range: 2048–8192 bytes Default: 2048 bytes
------------	--

Related Commands

dsppnni-mtu

Attributes

Log: yes State: active Privilege: SUPER_GP

Example

This example shows the **cnfpnni-mtu** command line that specifies the maximum PNNI packet size to 3002 bytes. Use **dsppnni-mtu** to display the specified information.

```
SanJose.7.PXM.a > cnfpnni-mtu 3002
```

```
SanJose.7.PXM.a > dsppnni-mtu
```

```
max packet size: 3002
```

```
SanJose.7.PXM.a >
```

cnfpnni-node

Configure PNNI Node—PXM45, PXM1E

The node-level **cnfpnni-node** command lets you:

- Modify the parameters of an existing logical node.
- Enable or disable a node. This ability applies to:
 - Parameters that require the node to be disabled before you can modify them (if you do not modify parameters that require a disabled node, you can modify one or more parameters with one execution of **cnfpnni-node**).
 - A situation where you created the node in the disabled state with **addpnni-node**.

The node configuration and state parameters you can modify are as follows:

- The ATM address—requires the node to be disabled
- The level of the node within the hierarchy—requires the node to be disabled
- The node ID—requires the node to be disabled
- The peer group ID—requires the node to be disabled
- Whether the node is the lowest node in the hierarchy
- The state of the node—enabled or disabled
- Whether connections can transit this node
- Whether or not the node is complex
- Whether the node supports point-to-multipoint connections

The preceding parameters appear as optional parameters in the syntax. The only required parameter for this command is the local *node index*. The local node index is a number in the range 1–10 that indicates the level of the logical node within a multi-peer hierarchy on the switch. If you do not know the value of this system-generated item, use **dsppnni-node**.



Note

When this command runs, existing calls are not affected. Modified parameters apply to new routing after the command finishes.

Disabling the Node for Parameters That Require It

For some of parameters, you must *first* disable the node. Applicable parameters are the:

- Level
- ATM address
- Node ID
- Peer group ID

For these parameters, three executions of **cnfpnni-node** are necessary:

1. **cnfpnni-node -enable false**
2. **cnfpnni-node** (*change parameters*, including those that do not require a disabled node)
3. **cnfpnni-node -enable true**

Be sure to synchronize applicable changes (such a change in level) throughout the network and follow up with **dsppnni-node** or other applicable display commands.

Syntax

```
cnfpnni-node <node-index> [-atmAddr atm-address] [-level level] [-nodeId node-id] [-pgId pg-id]
[-lowest {true | false}] [-enable {true | false}] [-transitRestricted {on | off}]
[-complexNode {on | off}] [-branchingRestricted {on | off}]
```

Syntax Description

<i>node-index</i>	<p>The node index specifies the relative position of a logical node within the hierarchy of a multi-peer group. The lowest level is 1. Each new logical node added to the hierarchy automatically gets the next higher index number, so you cannot configure the node index.</p> <p>Range: 1–10 Default: 1</p>
-atmAddr	<p>Specify the ATM address for this logical node. For you to change the ATM address, the node must be disabled. For details, see the section, “Disabling the Node for Parameters That Require It.” Note that only the lowest node in the hierarchy requires an ATM address.</p> <p>Default: Figure 2-7 shows the factory-set default.</p>
-level	<p>This parameter specifies the level of the node within the PNNI hierarchy. The level of the node is the number of bits in the node ID (-nodeId parameter) or peer group ID (-pg-id parameter). For example, the default level of 56 means that the node ID is 56 bits long. If you specify a level of 48, the node ID has a length of 48 bits.</p> <p>The maximum number of levels you can configure on a switch is 10. This limit is meaningful in a multi-peer group only. Although the level can be any value within the 1–104 range, selecting an 8-bit boundary makes network planning and address management easier. For example, using 56 for a level is more expedient than using a level of 59.</p> <p>Range: 1–104 bits Default: 56 bits</p>
-nodeId	<p>Specify the PNNI node identifier assigned to a PNNI node. The node ID consists of the PNNI hierarchy level (-level), followed by the length of the ATM address (addaddr length), followed by the ATM address (-atmAddr). As shown in Figure 2-7, <i>node-id</i> is a 22-byte, formatted hexadecimal string.</p> <p>Note Before you change the node ID, you must first use the cnfpnni-node command one time with the parameter string -enable false to disable the node.</p> <p>Default: Figure 2-7 shows the factory-set default.</p>

-pgId	<p>All members of a peer group have the same peer group identifier (pgID) and exist on the same level. (The level is either the existing number of bits or whatever you specify with -level).</p> <p>The default value of <i>level</i> is 56 (7 bytes), which specifies the length of -pgId to 7 bytes. However, the maximum length of -pgId is 14 bytes, so display commands always show -pgId as 14 bytes with trailing zeros filling the undefined fields. If you increase the value of <i>level</i>, you change the length, and therefore the value, of -pgId, but it will always be displayed as 14 bytes.</p> <p>Before you change the value of <i>pg-id</i>, disable the node by entering cnfpnni-node -enable false.</p> <p>This is a 14-byte, formatted hexadecimal string. Default: Figure 2-7 shows the factory-set default.</p>
-enable	<p>Specify the administrative status of the PNNI node. Before you change a node ATM address, node ID, peer group ID, or hierarchical level, the node must be disabled.</p> <p>true: Enable the node. false: Disable the node.</p> <p>Default: true</p>
-transitRestricted	<p>Specify whether connections can transit this node. You can disallow <i>via</i> connections for security reasons, to minimize traffic supported by either a low bandwidth node or a highly critical node, and so on.</p> <p>on: This node allows <i>via</i> connections. off: <i>Via</i> connections cannot transit this node.</p> <p>Default: off</p>
-complexNode	<p>Specify whether this node is a complex node. The lowest-level node cannot be a complex node.</p> <p>on: This node is a complex node. off: This node is not a complex node.</p> <p>Default: off</p>
-branchingRestricted	<p>Specify whether the PNNI node allows point-to-multipoint branches.</p> <p>on: This node does not allow point-to-multipoint branches. off: This node allows point-to-multipoint branches.</p> <p>Default: off</p>

**Caution**

Cisco factory-set defaults for address prefixes and the peer group ID share field values with the ATM address. If you change the peer group ID, you should change the corresponding fields in the ATM address and node identifier. (See [Figure 2-7](#) for the mapping between these addresses.)

Figure 2-7 Cisco Factory-shipped Defaults for PNNI Peer Group Identifier, PNNI Summary Address, ATM Address, and PNNI Node Identifier

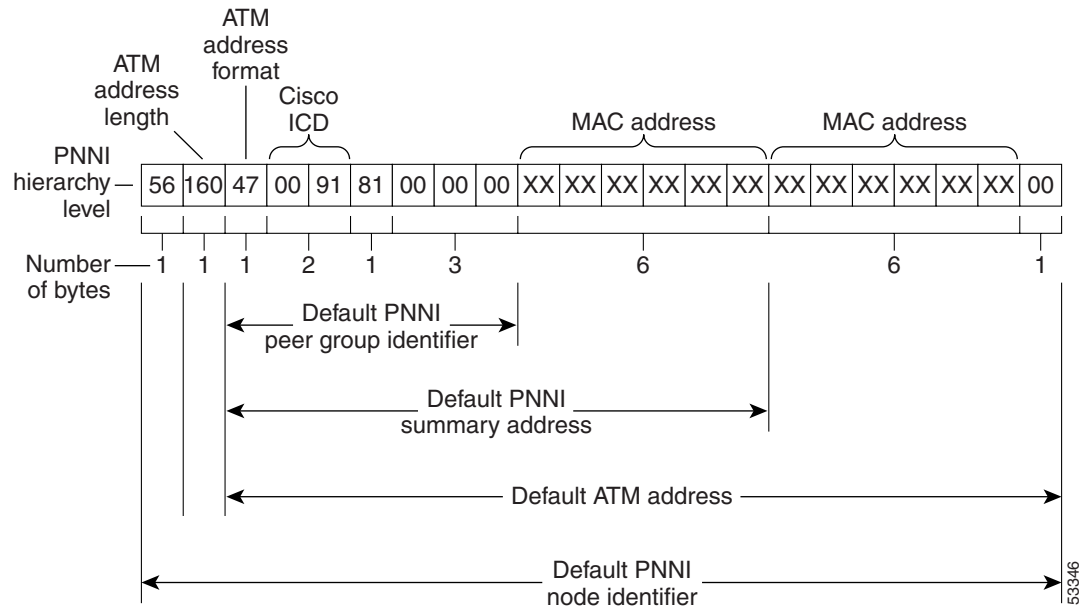

Usage Guidelines

All cards ship with default addresses. These defaults are provided for evaluation of the switch. Before or while you deploy a switch, you should change the default addresses by executing either **cnfpnni-node** or **addpnni-node**. The *Cisco MGX 8850 and MGX 8950 Switch Software Configuration Guide* explains node addressing in the section, “Guidelines for Creating an Address Plan.”

The ATM address, address prefixes, and peer group ID share some default field values, as shown in [Figure 2-7](#).

Related Commands

addpnni-node, **delpnni-node**, **dsppnni-node**, **addaddr**

Attributes

Log: yes State: active Privilege: SUPER_GP

Example

This example shows the **cnfpnni-node** command line that specifies the PNNI configuration values for a node that already exists on the network. The command line configures the PNNI node as follows:

- The PNNI hierarchy level is 56.
- The node ATM address is 47.0091 8100000000309409f1f1.00309409f1f1.01.
- The node PNNI identifier is 56:160:47.00918100000000309409f1f1.00309409f1f1.01.
- The node PNNI group identifier is 56:47.009181.0000.00. The length specified by the hierarchy level is 56 (8 bytes) the following 12 zeros are fill.

- The node is at the lowest level of the network PNNI hierarchy.
- The node is enabled.
- The node does not permit traffic to cross it on the way to other nodes.
- The node is not a complex node.
- The node permits branching.

Use **dsppnni-node** to display the PNNI configuration values.

```
SanJose.7.PXM.a > cnfpnni-node 1 -level 56 -nodeId 56:160:47.0091 81000000 00309409f1f1.00309409f1f1.01
-atmAddr 47.0091 81000000 00309409f1f1.00309409f1f1.01 -pgId 56:47.00.9181.0000.0000.0000.00
-lowest true -enable true -transitRestricted on -complexNode off -branchingRestricted off
```

```
SanJose.7.PXM.a > dsppnni-node
```

```
node index: 1                               node name: SanJose
Level..... 56                               Lowest..... true
Restricted transit.. on                       Complex node..... off
Branching restricted off
Admin status..... up                         Operational status.. up
Non-transit for PGL election.. off
Node id.....56:160:47.00918100000000309409f1f1.00309409f1f1.01
ATM address.....47.00918100000000309409f1f1.00309409f1f1.01
Peer group id.....56:47.00.9181.0000.0000.0000.00
SanJose.7.PXM.a >
```

cnfpnni-pkttrace

Configure PNNI Packet Trace—PXM45, PXM1E

This command applies to debugging. It causes the switch to check the PNNI packets transmitted and received at each peer. For example, if an interface is not receiving user-traffic, you can execute **dsppnni-pkttrace** to display packet information that can help you find the level and type of blockage.

The **cnfpnni-pkttrace** command specifies the trace command examines the contents of PNNI packets exchanged between two neighboring nodes. A PNNI packet consists of a Hello packet and the topology information packets.



Note

Executing **cnfpnni-pkttrace** can significantly increase operational overhead, thereby degrading network performance. You should consider executing this command while the node carries little or no live traffic. If you execute **cnfpnni-pkttrace** while live traffic is present, you may want to consider tracing the packets for one direction at a time (transmit or receive).

If you plan to use the optional **-portId** parameter but do not have the logical format of the port ID, use **dsppnport**. For details, refer to the Syntax Description of **cnfpnni-pkttrace**.

Syntax

```
cnfpnni-pkttrace {tx {on | off} | rx {on | off} } [node-index [-portId port-id | -svcIndex svc-index]]
```

Syntax Description

tx	Specify whether the switch traces transmitted packets. on: Trace the transmitted packets off: Do not trace the transmitted packets Default: (no default)
rx	Specify whether the switch traces received packets. on: Trace the received packets off: Do not trace the received packets Default: (no default)
<i>node-index</i>	The node index indicates the relative level of the logical node within a multi-peer group on the switch. The range is 1–10, and the lowest level is 1. Range: 1–10 Default: 1
-portId	The port ID in this instance has the format of the PNNI logical ID. The format is a 32-bit encoded number in the range 1–2147483648. If you do not have the logical port ID, use the dsppnport command. Provide dsppnport with the format of <i>slot.port</i> on a PXM1E or <i>slot:subslot.port:subport</i> on a PXM45. The output of dsppnport shows the logical number for the port ID. Use this value is for the -portID parameter.
-svcIndex	PNNI uses the SVC index as a reference to the SVC-based, logical, horizontal link. This parameter is meaningful only if you specify node-index. Default: none

Usage Guidelines

PNNI trace commands have characteristics that standard debug commands lack, namely:

- Trace commands debug interactions between different software modules or within a module.
- Trace output goes to a system trace buffer, not to the console.
- Tracing controls a more granular filtering of unnecessary debug output.

Related Commands

dsppnni-pkttrace, dsppnport, dsppnports

Attributes

Log: yes State: active Privilege: SERVICE_GP

Example

Configure then display a trace that examines the contents of PNNI Hello packets, as follows:

- The *transmit* packets are traced.
- The packet trace occurs at node index of 1 (the default for **cnfpnni-pkttrace** and therefore omitted).
- The packet trace takes place on the port identifier of 17504.

```
Geneva.7.PXM.a > cnfpnni-pkttrace tx 17504
PNNI/tx_packet on port 17504 at level 56
> 01:00010064 01010100 000038a0 47009181 00000000 309409f3 b8003094
> 02:09f3b801 47009181 00000000 309409f3 b8003094 09f3b801 38470091
> 03:81000000 00000000 000038a0 47009181 00000000 001a531c 2a00001a
```

```
Geneva.7.PXM.a > dsppnni-pkttrace tx -portId 17504
```

```
Node Index :1    Port id:            17504    Tx Pkt Trace on
```

```
Geneva.7.PXM.a >
```

cnfpnni-routing-policy

Configure PNNI Routing Policy—PXM45, PXM1E

The **cnfpnni-routing-policy** command specifies which routing policy values are used during UNI call setup. Routing policies control PNNI routing for your network.

The **cnfpnni-routing-policy** command specifies which routing policies are used for:

- Generating background routing tables
- Load balancing
- On-demand routing—applies to crankback or a situation where the node must route a call to a destination for which no route exists in the pre-computed routing tables

The two dynamic routing protocols are *shortest path* and *on-demand* routing.

Background Routing Tables

The background routing tables contain all routes within the peer group. The routes are calculated from information in the internal data base (IDB). When a topology change affects usable routes within the peer group, a PNNI topology state packet carries the formation to each node so it can update its IDB. The background routing tables are updated to reflect the change in routing parameters.

Routing tables are generated (or pre-computed) to support routing based on the shortest path.

- The administrative weight (AW) background routing table stores the AWs for all routes.
- The cell transfer delay (CTD) background routing table stores the CTD data for known routes.
- The cell delay variation (CDV) background routing table stores the CDV data for known routes.

On-demand routing is used if any of the following occur:

- All pre-computed routing tables are disabled.
- A route does not appear in the precomputed routing tables.
- Crankback is enabled within a designated transit list (DTL).



Caution

Poor routing policies can cripple or even crash a network. You should not change routing policies on a deployed network unless you have carefully planned the changes and know how the changes can affect the network.

Syntax

```
cnfpnni-routing-policy [-sptEpsilon epsilon] [-sptHolddown holddown]
[-bnPathHolddown bn-path-holddown] [-loadBalance {random | maxbw}]
[-onDemand {firstfit | bestfit}] [-awBgTable {on|off}] [-ctdBgTable {on|off}]
[-cdvBgTable {on|off}]
```

Syntax Description

-sptEpsilon	<p>The shortest path (SPT) <i>epsilon</i> you supply specifies a tolerance in the form of a percent that can influence which paths qualify as equal-cost during route calculation. A higher tolerance results in a broader range of path cost-values that can qualify as equal-cost. If two paths have very similar administrative weights (AWs), a large enough tolerance eliminates equal-cost as a routing factor because the routing algorithm regards the costs as equal.</p> <p>Range: 0–20 Default: 0, which means the cost of two paths must be <i>identical</i> to qualify as equal-cost</p> <p>The range of 0–20 for this parameter comes from the ATM Forum PNNI specification. However, the percent of tolerance that the numbers dictate is determined by individual vendors. Cisco Systems currently maps the following percentages for a switch:</p> <ul style="list-style-type: none"> 0: the total AWs along both directions of the route must be identical. 1-2: the total AWs along both directions of the route must be within 1.06%. 3-4: the total AWs along both directions of the route must be within 3.125%. 5-9: the total AWs along both directions of the route must be within 6.25%. 10-15: the total AWs along both directions of the route must be within 12.5%. 16-20: the total AWs along both directions of the route must be within 25.0%. <p>Note In the event of a crankback, PNNI uses on-demand routing. It starts a new calculation of the path based on the link information in the database. The SPT tables are not used, so sptEpsilon is not a factor in case of a crankback.</p>
-sptHolddown	<p>The minimum number of seconds between two consecutive calculations for generating routing tables. If a network is stable, it may not be necessary to generate routing tables every second: you can increase the value to reclaim CPU time needlessly used to update unchanging routing tables.</p> <p>Range: 1–600 seconds Default: 1</p>
-bnPathHolddown	<p>The minimum number of seconds between consecutive calculations of routing tables for border nodes. For a stable network, generating the routing tables every second may be unnecessary. If this case, you can increase the interval to save CPU time.</p> <p>Range: 2–600 seconds Default: 2</p>

-loadBalance	<p>PNNI relies on the load balance policy when it determines that the routes to a destination have equal cost. (PNNI determines routes to be identical according to the metrics in the AW, CDV, or CTD routing table.) Note that the SPT epsilon value can be a factor when PNNI calculates cost.</p> <p>The choice for load balancing is “random” or “maxbw.” Type the entire word.</p> <p>With “random” load balancing, PNNI randomly chooses between the equal cost routes. This rule requires less computational overhead.</p> <p>With “maxbw” load balancing, PNNI selects the route with more available bandwidth when it chooses between equal cost routes. This rule has more overhead due to ongoing comparison of available bandwidth on the routes.</p> <p>Default: no default</p>
-onDemand	<p>On-demand routing applies to crankback or a situation where the node must route a call to a destination for which no route exists in the pre-computed routing tables. This policy can also determine whether an SPVC or SPVP receives the optimal route after “grooming.” (See cnfrteopt description.) The on-demand policy is either “firstfit” and “bestfit.”</p> <p>With firstfit (the default), PNNI selects the first route to the destination. The firstfit policy may be the most suitable policy where the network topology often changes or if a higher call rate is important. This approach minimizes search time but may not result in the optimal route.</p> <p>With bestfit, PNNI selects a route based on:</p> <ul style="list-style-type: none">• The route with the lowest cost (see AW in the cnfpnni-intf description and <i>maximum cost</i> in the addcon description because these parameters are closely related).• Link verification.• Path constraint checks.• Avoidance of blocked nodes and links.• Checking limits in the designated transit list (DTL). <p>With bestfit, PNNI selects the optimum route. This policy involves greater computing overhead. The search-time depends on the density and complexity of the network and whether the network topology changes little. If the network topology tends to stay the same, bestfit is the better policy.</p> <p>Default: firstfit</p>
-awBgTable	<p>Enable or disable the background routing table for AW.</p> <p>on: The background routing table of AW is enabled.</p> <p>off: The background routing table of AW is disabled.</p> <p>Default: on</p>

-ctdBgTable	<p>Enable or disable the background routing table of CTD. The CTD parameter is the interval between a cell exiting the source PNNI node and entering the destination PNNI node.</p> <p>on: The background routing table of CTD is enabled. off: The background routing table of CTD is disabled.</p> <p>Default: on</p>
-cdvBgTable	<p>Enable or disable the background routing table of CDV. The CDV parameter is a component of cell transfer delay, and is a quality of service (QoS) delay parameter associated with CBR and VBR service. Cell Delay Variation is the variation of delay between cells, measured peak to peak.</p> <p>on: The background routing table of CDV is enabled. off: The background routing table of CDV is disabled.</p> <p>Default: on</p>

Related Commands

dsppnni-routing-policy

Attributes

Log: yes State: active Privilege: SUPER_GP

Example

Specify the following routing policy:

- Only paths with identical values qualify as equal-cost paths.
- The routing tables are generated every 0.1 seconds.
- The load balancing is purely random.
- On-demand routing selects to the optimal route.
- The background routing table for AW is enabled.
- The background routing table for cell transfer delay is enabled.
- The background routing table for cell delay variation is enabled.

You can confirm your settings with the related command **dsppnni-routing-policy**.

```
Geneva.7.PXM.a > cnfpnni-routing-policy -sptEpsilon 0 -sptHolddown 1 -loadBalance random
-onDemand bestfit -awBgTable on -ctdBgTable on -cdvBgTable on
```

```
Geneva.7.PXM.a > dsppnni-routing-policy
```

```
SPT epsilon..... 0 Load balance..... random
SPT holddown time... 1 On demand routing... best fit
SPT path holddown time 2 AW Background Table on
CTD Background Table on CDV Background Table on
```

```
Geneva.7.PXM.a >
```

cnfpnni-scope-map

Configure PNNI Scope Map—PXM45, PXM1E

The **cnfpnni-scope-map** command specifies how UNI 4.0 address scope values are mapped to PNNI hierarchal levels. The purpose of scope values is to support granularity between the organizational hierarchy and to support growth. The organizational scope consists of 15 levels. These parameters are stored in the scope map table.

Application of Scope Levels

This section describes the applications of the organizational scopes as defined in Section A5.2 of UNI Signalling 4.0. If you already know the application, you can directly refer to the Syntax Description.

Level 1—Local Network

The level 1 scope maps to the concept of a physical network. Using Ethernet as an example, a single Ethernet segment and multiple Ethernet segments extended by repeaters or bridges can be treated as a local network. Therefore, the network operator configures the mapping of membership scope “local network” to map to the routing levels that fit the needs of the local scope concept. For example, the mapping can be to a bottom-level peer group or a peer group of higher level in a PNNI routing hierarchy to simulate extended physical networks.

Levels 2, 3, and 4—LocalNetworkPlusOne, LocalNetworkPlusTwo, SiteMinusOne

Scope levels 2–4 can be mapped to ATM sub-networks that do not use inter-building or wide-area links.

Level 5—IntraSite

Scope level 5 identifies the inclusive routing hierarchies that are not geographically separated. The intra-site scope allows the network operator to confine the traffic within a local location and therefore avoid using wide-area links or inter-building links.

Levels 6 and 7—SitePlusOne and OrganizationMinusOne

Scope levels 6 and 7 can identify ATM networks that may use inter-building links or wide-area links.

Level 8—IntraOrganization

The Intra-Organization scope identifies ATM networks that represent the *inclusive* routing hierarchy of an autonomous organization. An autonomous organization is an organization that has administrative authority over the network. The ATM networks identified by this membership scope therefore may use inter-building and wide-area links.

Levels 9 and 10—OrganizationPlusOne and CommunityMinusOne

The values 9-10 can be used to identify union of more than one organizations.

Levels 11, 12, 13, and 14—IntraCommunity, CommunityPlusOne, Regional, and InterRegional

Scope levels 11–14 can be used to identify ATM networks that represent a collection of autonomous organizations. These networks are organized by a provider or organizational partnership.

Level 15—Global

Scope level 15 represents all autonomous organizations that form a connected, private ATM network.

Syntax

cnfpnni-scope-map <scope> <level>

Syntax Description

<i>scope</i>	<p>The scope is indicated by 1 of 15 levels. A description of the application of these levels appears at the beginning of this command description.</p> <p>Range: 1–15 (0 is reserved), where:</p> <ul style="list-style-type: none"> 1 = LocalNetwork 2 = LocalNetworkPlusOne 3 = LocalNetworkPlusTwo 4 = SiteMinusOne 5 = IntraSite 6 = SitePlusOne 7 = OrganizationMinusOne 8 = IntraOrganization 9 = OrganizationPlusOne 10 = CommunityMinusOne 11 = IntraCommunity 12 = CommunityPlusOne 13 = Regional 14 = InterRegional 15 = Global <p>Default = none.</p>
<i>level</i>	<p>Specify the PNNI level to which the UNI 4.0 address scope is mapped.</p> <p>Range: 1–104</p> <p>Default = 56</p>

Related Commands

dsppnni-scope-map

Attributes

Log: yes State: active Privilege: SUPER_GP

Example

Configure the scope map table for the following:

- The variable *scope* is 1.
- The variable *level* is 56.

These values map the UNI 4.0 scope '1' to the PNNI hierarchical level '56'.

```
Geneva.7.PXM.a > cnfpnni-scope-map 1 56
```

```
Geneva.7.PXM.a > dsppnni-scope-map
```

UNI	Scope	Pnni Routing Level
-----	-----	-----
	LocalNetwork(1)	56
	LocalNetworkPlusOne(2)	56
	LocalNetworkPlusTwo(3)	56
	SiteMinusOne(4)	40
	IntraSite(5)	40
	SitePlusOne(6)	32
	OrganizationMinusOne(7)	32
	IntraOrganization(8)	24
	OrganizationPlusOne(9)	24
	CommunityMinusOne(10)	24
	IntraCommunity(11)	8
	CommunityPlusOne(12)	8
	Regional(13)	0
	InterRegional(14)	0
	Global(15)	0

```
Geneva.7.PXM.a >
```

cnfpnni-svcc-rcc-timer

Configure PNNI Switched Virtual Connection Routing Control Channel (SVCC-RCC) Timer—PXM45, PXM1E

The **cnfpnni-svcc-rcc-timer** command lets you specify the initial PNNI SVCC-based variables for a network node. Logical group nodes (LGNs) use SVCC-RCCs to exchange routing information.

Syntax

```
cnfpnni-svcc-rcc-timer <node-index> [-initTime init-time] [-retryTime retry-time]
[-callingIntegrityTime calling-integrity-time] [-calledIntegrityTime called-integrity-time]
```

Syntax Description

<i>node-index</i>	The node index indicates the relative level of the logical node within a multi-peer group on the switch. The range is 1–10, and the lowest level is 1. Range: 1–10 Default: 1
-initTime	The number of seconds this node waits before it advertises its choice of preferred SVCC to a neighbor with a numerically lower ATM address. This node does so after determining that such an SVCC should be established. Range: 1–10 seconds Default: 10
-retryTime	The number of seconds this node waits before it attempts to re-establish an apparently necessary and viable SVCC-based RCC that was unexpectedly torn down. Range: 10–60 seconds Default: 60
-callingIntegrityTime	The number of seconds the node waits while it attempts to set up an SVCC as the calling party. If the SVCC is not fully established within this time period, the node tears down the connection. Range: 5–300 Default: 300
-calledIntegrityTime	The number of seconds the node waits while it attempts to set up an SVCC as the called party. If the SVCC is not fully established within this time period, the node tears down the connection. Range: 10–300 Default: 300

Related Commands

dsppnni-svcc-rcc-timer

Attributes

Log: yes State: active Privilege: SUPER_GP

cnfpnni-timer

Configure PNNI Timers—PXM45, PXM1E

The **cnfpnni-timer** command specifies the initial PNNI timer values and significant change thresholds of a network node. You must carefully plan the use of this command because modifying a timer can significantly change network efficiency.

Syntax

```
cnfpnni-timer <node-index> [-ptseHolddown ptse-holddown] [-helloHolddown hello-holddown]
[-helloInterval hello-interval] [-helloInactivity-factor hello-inactivity-factor]
[-horizontalLinkInactivityTime horizontal-link-inactivity-time]
[-ptseRefreshInterval ptse-refresh-interval] [-ptseLifetimeFactor ptse-lifetime-factor]
[-retransmitInterval retransmit-interval] [-ptseDelayedAckInterval ptse-delayed-ack-interval]
[-avcrPm avcr-pm] [-avcrMt avcr-mt] [-cdvPm cdv-pm] [-ctdPm ctd-pm]
```

Syntax Description

<i>node-index</i>	The node index indicates the relative level of the logical node within an MPG on the switch. The range is 1–10. The lowest level is 1. Range: 1–10 Default: 1
-ptseHolddown	The holddown value is the time the switch waits before it broadcasts PTSEs. The increments are tenths of a second. For example, -ptseHolddown 1 means 0.1 second, and -ptseHolddown 10 means 1 second, and so on. Range: 0.1–1000 Default: 10 (1 second)
-helloHolddown	Specify the initial value for the Hello hold down timer that the node uses to limit the rate at which it sends Hellos. Units: 100 ms. 1 = 0.1 seconds Range: 0.1–1000 Default: 10 (1 second)
-helloInterval	Specify the initial value for the Hello timer in seconds. The value limits the rate at which the node sends Hellos. Range: 1–300 seconds Default: 15 seconds
-helloInactivityFactor	The product of the <i>hello-inactivity-factor</i> and the peer neighbor <i>hello-interval</i> is the maximum time (in sec) that the neighbor is considered alive after the last reception of a Hello packet. Range: 1–50 seconds Default: 5 seconds

-ptseRefreshInterval	The initial time allowed for the PTSE to re-originate. Range: 30–1800 seconds Default: 1800 seconds
-ptseLifetimeFactor	The value for the lifetime multiplier, expressed as a percent. The product of it and the <i>ptse-refresh-interval</i> is the initial value of the remaining lifetime of a self-created PTSE. Range: 101–1000 percent Default: 200
-retransmitInterval	The period between retransmissions of unacknowledged DS, PTSE request, and PTSP. Range: 5–60 seconds Default: 5 seconds
-ptseDelayedAckInterval	Specify the minimum interval between transmissions of delayed PTSE acknowledgment packets. Units: 100 milliseconds. 1 = 0.1 seconds. Range: 1–10 Default: 10 (1 second)
-avcrPm	Specify the proportional multiplier used in the algorithms that determine significant change for available cell rate (AvCR) parameters. <i>avcr-pm</i> is expressed as a percentage. Range: 1–99 percent Default: 50 percent
-avcrMt	Specify the minimum threshold used in the algorithms that determine significant change for available cell rate (AvCR) parameters which are expressed as a percentage. You can change this value to minimize the overhead created by advertisements triggered by AVCR changes. <i>avcr-mt</i> is expressed as a percentage. Range: 1–99 percent Default: 3 percent
-cdvPm	The <i>cdv-pm</i> is a percent. It specifies the proportional multiplier used in the algorithms that determine significant change for cell delay variation (CDV). You can change this percent to minimize the overhead created when CDV changes trigger advertisements. Range: 1–99 percent Default: 25 percent
-ctdPm	The <i>ctd-pm</i> is a percent. It specifies the proportional multiplier used in the algorithms that determine significant change for cell transfer delay (CTD) parameters. You can change this percent to minimize the overhead created when CTD changes trigger advertisements. Range: 1–99 percent Default: 50 percent

Usage Guidelines

PTSE packets update the peer group when network changes occur. Your network should run fine with the defaults PTSE timing parameters. Networks that have properties significantly different from the norm may perform better if you optimize some of the PTSE parameters, but you should change these parameters carefully, and test the network before introducing live traffic.

For example, if no one is permitted to change a network topology (perhaps for test purposes), you may decide that the default **-ptseHolddown** value (1 sec) is too small, causing sequential broadcasts of identical PTSE packets. Further reason for making such a change would be given if the network was a small and it's connections were short. Inversely, it may warrant a smaller **-ptseHolddown** value if many changes are being made to a network, or if it was large, or if it had many long connections. These are only examples—these changes should only be made by network experts.

Related Commands

dsppnni-timer

Attributes

Log: yes State: active Privilege: SUPER_GP

Example

This example shows the **cnfpnni-timer** command line that is set with the following parameter values:

- The node broadcasts Hello packets every 1.2 seconds.
- The node broadcasts Hello packets every 1.2 seconds.
- The node Hello timer is 15 seconds.
- The node *hello-inactivity-factor* is 5 seconds.
- The node recreates PTSEs every 1800 seconds (30 minutes).
- The node evaluates the initial PTSE lifetime by multiplying the *ptse-refresh-interval* (1800 seconds) by 200.
- The node retransmits every 5 seconds.
- If the node broadcasts a PTSE and the PTSE is not acknowledged, the node waits 1 second to rebroadcast its PTSE.
- The node multiplies an algorithm by 3% to determine the value that qualifies as a significant change for AvCR parameters.
- The node multiplies an algorithm by 50% to determine the value that qualifies as the minimum threshold for significant change of AvCR parameters.
- The node multiplies an algorithm by 25% to determine the value that qualifies as a significant change for CDV parameters.
- The node multiplies an algorithm by 50% to determine the value that qualifies as a significant change for CTD parameters.

You can confirm your settings with the related command **dsppnni-timer**.

```
SanJose.7.PXM.a > cnfpnni-timer 1 -ptseHolddown 120 -helloHolddown 120 -helloInterval 15
-helloInactivity-factor 5 -horizontalLinkInactivityTime 10 -ptseRefreshInterval 1800
-ptseLifetimeFactor 200 -retransmitInterval 50 -ptseDelayedAckInterval 10 -avcrPm 3
-avcrMt 50 -cdvPm 25 -ctdPm 50
```

```
SanJose.7.PXM.a > dsppnni-timer 1
node index: 1
Hello holddown(100ms)... 12 PTSE holddown(100ms)... 12
Hello int(sec)..... 15 PTSE refresh int(sec).. 1800
Hello inactivity factor. 5 PTSE lifetime factor... 200
Retransmit int(sec)..... 5
AvCR proportional PM... 3 CDV PM multiplier..... 25
AvCR minimum threshold.. 50 CTD PM multiplier..... 50
Peer delayed ack int(100ms)..... 10
Logical horizontal link inactivity time(sec).. 10
```

```
Geneva.7.PXM.a >
```

cnfnpportacc

Configure Port Access—PXM45, PXM1E

The **cnfnpportacc** command lets you *associate* an ATM filter set with a port (after you *create* the filter set with **addfltset**). You must specify at least one filter set if you use this command.

Syntax

```
cnfnpportacc <portid> [-in in-filter-name] [-out out-filter-name]
```

Syntax Description

portid The format of the PNNI physical port identifier can vary, as follows:

- On a PXM45: *slot:subslot.port:subport*
- On a PXM1E for UNI/NNI back card: *slot:subslot.port:subport*. On the UNI/NNI back card, the subslot is always 2, but the *slot* depends on the chassis, as follows:
 - In an MGX 8850 chassis, *slot* is always the logical slot 7.
 - In an MGX 8830 chassis, *slot* is always the logical slot 1.
- On a PXM1E for a narrowband service module (NBSM): *slot.port*.

For more details, see the section, “[PNNI Format](#),” in [Chapter 1](#), “[Introduction](#).”

-in *in-filter-name*: the name of the filter set that applies to SETUP messages that arrive at the port.

-out *out-filter-name*: the name of the filter set that applies to SETUP messages that leave the port.

Related Commands

delpnportacc, **addfltset**

Attributes

Log: yes State: active Privilege: GROUP1

cnfnpportcac

Configure Port Connection Admission Control—PXM45, PXM1E

The **cnfnpportcac** command lets you reserve a percent of the bandwidth for an individual service type. The new configuration applies to new and existing calls. You can run this command whether the port is active or in the provisioning state.

The *bookfactor* is the percent of utilization. It applies to connection admission control (CAC). When the default for **maxbw** and **minbw** is used for all service types, the common AvCR is advertised for all the service types.

You must specify at least one of the optional keywords.

Syntax

```
cnfnpportcac <portid> <service_category> [-bookfactor utilization-factor]
[-maxbw max-bw-percent] [-minbw min-bw-percent] [-maxvc max-vc-percent]
[-minvc min-vc-percent] [-maxvcbw max-vc-bw]
```

Syntax Description

<i>portid</i>	The format of the PNNI physical port identifier can vary, as follows: <ul style="list-style-type: none"> On a PXM45: <i>slot:subslot.port:subport</i> On a PXM1E for UNI/NNI back card: <i>slot:subslot.port:subport</i>. On the UNI/NNI back card, the subslot is always 2, but the <i>slot</i> depends on the chassis, as follows: <ul style="list-style-type: none"> In an MGX 8850 chassis, <i>slot</i> is always the logical slot 7. In an MGX 8830 chassis, <i>slot</i> is always the logical slot 1. On a PXM1E for a narrowband service module (NBSM): <i>slot.port</i>. For more details, see the section, “PNNI Format,” in Chapter 1, “Introduction.”
<i>service_category</i>	Service category (service type). Choices are: cbr, rtvbr, nrtvbr, ubr, or abr.
-bookfactor	The service category utilization factor (SCUF) for a service type. Range: 1–200 Default: 100
-maxbw	The <i>max-bw-percent</i> is the maximum percentage of bandwidth for a service category on this port. Range: 0–100.0000 Default: 100
-minbw	The <i>min-bw-percent</i> is the minimum percentage bandwidth for a service category on this port. Range: 0–100.0000 Default: 0
-maxvc	The <i>max-vc-percent</i> is maximum percent of VCs for a service category on this port. Range: 0–100 Default: 100

-minvc	The <i>min-vc-percent</i> : is the minimum percent of VCs for a service category on this port. Range: 0–100 Default: 0
-maxvcbw	The <i>max-vc-bw</i> : maximum bandwidth, in cells per second, as specified by the PCR allowed for a VC in a service category on this port. Range: 0 through the maximum possible line rate Default: 0 (disabled)

Related Commands

dsppnportcac

Attributes

Log: yes State: active Privilege: GROUP1

Usage Guidelines

This section uses three examples to describe the booking factor.

- For no overbooking or oversubscription, suppose that a user has a 100-Mbit link and the booking factor is 100.
 - PNNI advertises 100 Mbits to the network.
 - The link on the service module is configured for 100 Mbits.
- A booking factor less than 100% results in link oversubscription because the bandwidth booked for each connection exceeds the configured bandwidth for the connection. This situation is referred to as overbooking.

Suppose that, for the same 100-Mbit link, the booking factor is 10.

- PNNI advertises 1000 Mbits (calculated by $100 * 100/10 = 1000$)
 - The link is configured on the service module for 100 Mbits.
- Booking factors greater than 100% result in link under-subscription, and the bandwidth booked for a connection exceeds the connection's configured bandwidth. This situation is referred to as under-booking.

For the same 100-Mbit link, the booking factor is 200.

- PNNI advertises 50 Mbits (calculated as $100 * 100/200 = 50$)
- The link is configured on the service module for 100 Mbits.
- The policing bandwidth is based on the configured bandwidth and not the book factor. For a 10-Mbit connection, the policing is 10 Mbits, regardless of the booking factor.

cnfnpportcc

Configure Port Call Control—PXM45, PXM1E

The **cnfnpportcc** command lets you set certain call control parameters for a specific port, as follows:

- You can specify maximum root and leaf connections for point-to-multipoint (P2MP) connections
- To control the types of connections that a port can accept, you can specify that the port rejects incoming connection requests for one or more of the following types:
 - SVCs/SVPs.
 - SPVCs/SPVPs, dual-ended (the familiar master/slave endpoints).
 - SPVCs/SPVPs, single-ended, with non-persistent slave endpoints at the local port.
- For P2MP connections, you can specify a *subscription* option

Choosing the enable for the subscription option depends on the intelligence of the CPE. If the CPE can process an ADDPARTY message, leave the subscription option disabled. (If this option is disabled, the port sends an ADDPARTY upon receipt of an ADDPARTY that terminates on an existing leaf.) If you enable the subscription option, the port sends a SETUP message instead of ADDPARTY and therefore forces the creation of a new branch or leaf on the switch. This option is available to either a private UNI or public UNI only.



Note

You can use this command whether the port is active or in the provisioning state.

Changes apply to new incoming calls, not existing calls. For example, if the port has non-persistent endpoints when you block this type of endpoint, the existing endpoints remain.

Syntax

```
cnfnpportcc <portid> < [-maxp2mproot max-p2mp-root] [-maxp2mpleaf max-p2mp-leaf]
[-svcblock {yes | no}] [-spvcblock {yes | no}] [-nonpersblock {yes | no}] [-subscribe {yes | no}] >
```

Syntax Description

You must specify at least one optional keyword.

<i>portid</i>	The format of the PNNI physical port identifier can vary, as follows: <ul style="list-style-type: none"> • On a PXM45: <i>slot:subslot.port:subport</i> • On a PXM1E for UNI/NNI back card: <i>slot:subslot.port:subport</i>. On the UNI/NNI back card, the subslot is always 2, but the <i>slot</i> depends on the chassis, as follows: <ul style="list-style-type: none"> – In an MGX 8850 chassis, <i>slot</i> is always the logical slot 7. – In an MGX 8830 chassis, <i>slot</i> is always the logical slot 1. • On a PXM1E for a narrowband service module (NBSM): <i>slot.port</i>. <p>For more details, see the section, “PNNI Format,” in Chapter 1, “Introduction.”</p>
<i>-maxp2mproot</i>	The <i>max-p2mp-root</i> : maximum number of root VCs on this port. In the current release, this parameter is meaningless. Default: 1000

-maxp2mpleaf	The <i>max-p2mp-leaf</i> : maximum number of leaf VCs on this port. In the current release, this parameter is meaningless. Default: 4095
-svcblock	Enables or disables <i>SVC blocking</i> on the port. <ul style="list-style-type: none"> • Yes (enable): The port accepts no call setups. • No (disable): The port accepts call setups. Default: no.
-spvcblock	Enables or disables <i>SPVC blocking</i> on the port. Type “yes” or “no.” <ul style="list-style-type: none"> • Yes (enable): an attempt to add an SPVC through addcon or Cisco WAN Manager fails. The resulting error message is: “ERR: SPVC blocking is enabled on this interface.” • No (disable): you can add SPVCs through addcon or Cisco WAN Manager. Default: no
-nonpersblock	Enables or disables <i>blocking</i> of calls with non-persistent slave endpoints on the port. Type “yes” or “no.” <ul style="list-style-type: none"> • Yes (enable): an attempt to terminate a non-persistent slave endpoint on the port fails. The resulting error message is: “ERR: non-persistent blocking is enabled on this interface.” • No (disable): SPVCs with non-persistent endpoints can terminate on the port. Default: no
-subscribe	The subscription option applies to a port that supports P2MP connections. Type yes to cause the port to send SETUP rather than ADDPARTY messages to the CPE.

Related Commands

dsppnportcc

Attributes

Log: yes State: active Privilege: GROUP1

cnfnpnportie

Configure PNNI Port Information Element—PXM45, PXM1E

The **cnfnpnportie** command configures a port to take one of three actions on a priority services information element (PS IE) or a closed user group information (CUG IE).



Note

The current release supports only the CUG IE.

The choices with this command are to allow the IE, disallow the IE, or let the port automatically determine whether to send the IE. The effects of allowing and disallowing an IE are as follows:

- If you specify “allowed,” the signalling messages can carry the IE in the egress direction.
- If you specify “disallowed,” the respective IE is stripped from the signalling message before it goes to the egress direction of the port.
- If you use the default of “auto,” the node determines the action to take on the IE in the egress direction based on the interface type, as follows:
 - On a UNI of any type, the node strips the IE from the signalling message before the message goes to the interface.
 - On a PNNI or AINI, the signaling messages carry the IE in the egress direction.

Additionally, some behaviors depend on the type of IE and the interface, as follows:

- For a CUG IE on an IISP or EIISP, the setting is ignored because the node always strips the CUG IE on these interfaces.
- For the PS IE, the setting is ignored on an IISP but not an EIISP. The node always strips the PS IE on an IISP.



Note

If a P2P or P2MP connection is cranked back and if the subsequent egress interface that PNNI selects is a UNI, PNNI sends the appropriate CUG index IE. If the egress interface is NNI, it re-uses the CUG IC IE.

The CUG index IE is supported on both public and private UNI interfaces that have at least Q.2931 capability. The IE signalling also depends on the CUG provisioning at the interface address, as follows:

- If CUG is not provisioned, the CUG index IE signalling is not allowed.
- The egress signalling of the CUG index IE is additionally restricted to UNI interfaces that you have configured to allow transmission of the CUG IEs.
- Receipt of the CUG index IE in an add-party message at the *ingress* UNI constitutes an error as per ITU-T recommendation. Therefore, the MGX node does not signal the CUG index IE in an add-party message over the *egress* of a public UNI.

On non-UNI egress interfaces, the CUG IC IE is supported as follows:

- Supported on PNNI and AINI. However, the CUG IC IE is still subject to the IE blocking you configure for a particular interface.
- Not transmitted over an IISP or EIISP link.

Additionally, the PS IE can be passed along to other non-UNI interfaces if the passalong request bit is set in the IE and if those interfaces possess the passalong capability.

Syntax

```
cnfnpportie <portid> [-psie {auto | allowed | disallowed}] [-cugie {auto | allowed | disallowed}]
```

Syntax Description

<i>portid</i>	Identifies a PNNI physical port. The format is <i>slot:subslot,port:subport</i> .
-psie	The priority services information element. <ul style="list-style-type: none"> • auto • allowed • disallowed Default: auto
-cugie	The closed user group information element can be one of the following: <ul style="list-style-type: none"> • auto • allowed • disallowed Default: auto

Related Commands

dsppnportie

Attributes

log: yes State: active Privilege: GROUP1

Example

For port 12:12.1:1, specify the PS IE to be auto, and disallow the CUG IE,

```
pop3-1.7.PXM.a > cnfnpportie 12:12.1:1 -cugie disallow
```

cnfnpportlosscallrel

Configure PNNI Port Loss of Signal Call Release—PXM45, PXM1E

The **cnfnpportlosscallrel** command lets you apply one of the following controls to connection de-routing on a port due to a loss of signal (LOS):

- Create a de-route delay of 0 seconds on a port by overriding the system's *automatic* delay for de-routing calls upon LOS.
- Configure a specific number of seconds to delay the de-routing of a call upon LOS.

With standard operation, PNNI waits for the SSCOP “no-response” and T309 timers to expire before it releases calls on a broken link. The default values for these timers are 30 seconds and 10 seconds, respectively. The system-level default (and therefore the default for **cnfnpportlosscallrel**) is to retain all the calls in case of a transitory loss of connectivity for the duration of these timers. However, this pause may unnecessarily delay the re-routing of connections. Therefore, the **cnfnpportlosscallrel** feature gives you the option of controlling the call release as needed for a particular port.

Before you configure the de-route delay part of this feature, note the following characteristics:

- Although the LOS call release feature must be enabled for the delay timer to work, the delay timer option subsequently takes precedence if you configure it. (See the Syntax Description for applicable parameters.) Thus, this command lets you override the standard, timer-based delays and specify that no delay occur in connection derouting on the port, then you can also configure a specific delay.
- With de-route delay enabled, the following occurs when a port goes into provisioning (due to card removal or when a resource partition is deleted)
 - The near end releases the connections.
 - The far end detects LOS and holds the connections.
- If the configuration for the de-route delay feature is different at the two ends of an NNI, or if the far end is another vendor's switch, this feature does not work effectively.
- If a de-route delay is configured, the delay value should be the same throughout the network.
- For the de-route delay feature to work, ILMI Secure Link Procedures should be disabled on the port through the **cnfilmiproto** command. If this ILMI feature remains enabled, the call release begins as soon as the ILMI protocol resets. Note also that disabling ILMI Secure Link Procedures on PNNI NNIs has no impact on those interfaces.
- For an SPVC with connectivity check (CC) enabled, the port sends AIS towards CPE during the de-route delay period (if configured).
- If a physical line has a mix of UNIs and NNIs, AIS is delayed on both interface types.
- Two commands have parameters that let you turn off AIS towards CPE during the delay period. For a port with IMA groups, use the **cnfatmimagrp**.
- If the deroute delay timer is configured with a value greater than the SSCOP “no-response” timer, and if the SSCOP link resets before the expiry of the de-route delay timer, release initiation occurs immediately upon the reset of the SSCOP link. To avoid this situation, you should configure the de-route delay timer between zero and a value less than the SSCOP no-response timer value.
- If the de-route delay time has a value greater than the SSCOP no-response timer, expiry of the SSCOP no-response time triggers a reset of the SSCOP link, then connection de-routing begins. To avoid de-routing caused by expiry of the SSCOP no-response timer, make the de-route delay timer less than the SSCOP no-response timer.
- If you use **dnport** to down a port, the system treats this event as an LOS, and connection de-routing is delayed according to the delay-timer. If you use **dnnpport** to down a PNNI port, no delay occurs.

Syntax

```
cnfnpportloscallrel <portid> <yes | no> [-delay <deroute-delay-val>]
```

Syntax Description

<i>portid</i>	The format of the PNNI physical port identifier can vary, as follows: <ul style="list-style-type: none"> On a PXM45: <i>slot:subslot.port:subport</i> On a PXM1E for UNI/NNI back card: <i>slot:subslot.port:subport</i>. On the UNI/NNI back card, the subslot is always 2, but the <i>slot</i> depends on the chassis, as follows: <ul style="list-style-type: none"> In an MGX 8850 chassis, <i>slot</i> is always the logical slot 7. In an MGX 8830 chassis, <i>slot</i> is always the logical slot 1. On a PXM1E for a narrowband service module (NBSM): <i>slot.port</i>.
yes no	Specifies whether immediate call release is enabled upon LOS. To enable this feature—to remove the <i>standard</i> deroute delay—type “yes.” A “no” means that de-routing begins upon expiry of the SSCOP no-response and T309 time. Default: no.
-delay	This parameter specifies the number of seconds the switch waits before it begins de-routing connections on the port. If you specified “no” for the LOS call release feature, this -delay parameter has no effect. The delay you specify here should be less than the value of the SSCOP no-response time. (See dspsscop for the current no-response timer value and cnfsscop -norsptmr to specify the delay.) A warning message appears if the delay is greater than the sum of the SSCOP no-response timer and the T309 value. <ul style="list-style-type: none"> Range: 0–59 seconds Default: 0

Related Commands

dsppnportloscallrel, **cnfsscop**, **dspsscop**

Attributes

Log: yes State: active Privilege: SUPER_GP

Example

Enable call release upon LOS for port 3:1.1:1, then confirm its status.

```
8850_NY.8.PXM.a > cnfnpportloscallrel 3:1.1:1 yes
```

```
8850_NY.8.PXM.a > dsppnportloscallrel 3:1.1:1
Deroute Delay: 0 seconds
Call release on Los:enabled
```

Enable a call release upon LOS and a deroute delay of 10 seconds for port 1:1.2:2.

```
8850_NY.8.PXM.a > cnfnpportloscallrel 1:1.2:2 yes -delay 10
8850_NY.8.PXM.a > dsppnportloscallrel 1:1.2:2
Deroute Delay: 10 seconds
Call release on Los:enabled
```

cnfnpportncci

Configure Network Call Correlation Identifier—PXM45, PXM1E

The **cnfnpportncci** command lets you determine the action that PNNI takes on a call correlation identifier. The possible responses to this identifier are:

- Forward the identifier.
- Discard the identifier.
- Assign a new identifier.



Note

This command applies only to UNI 4.0 and AINI. It does not apply to UNI 3.x, IISP, and PNNI.

Syntax

```
cnfnpportncci <portid> [-action {forward | discard | assign}]
```

Syntax Description

<i>portid</i>	<p>The format of the PNNI physical port identifier can vary, as follows:</p> <ul style="list-style-type: none"> • On a PXM45: <i>slot:subslot.port:subport</i> • On a PXM1E for UNI/NNI back card: <i>slot:subslot.port:subport</i>. On the UNI/NNI back card, the subslot is always 2, but the <i>slot</i> depends on the chassis, as follows: <ul style="list-style-type: none"> – In an MGX 8850 chassis, <i>slot</i> is always the logical slot 7. – In an MGX 8830 chassis, <i>slot</i> is always the logical slot 1. • On a PXM1E for a narrowband service module (NBSM): <i>slot.port</i>. <p>For more details, see the section, “PNNI Format,” in Chapter 1, “Introduction.”</p>
-action	<p>The action that the controller takes on the network call correlation identifier: the choices are “forward,” “discard,” and “assign.” The default is forward.</p>

Related Commands

dsppnportncci

Attributes

Log: yes State: active Privilege: GROUP1

cnfnpportrange

Configure Port Range—PXM45, PXM1E

The **cnfnpportrange** command lets you specify a range of VPIs and VCIs on a port for SVCCs or SVPCs for the purpose of screening calls from another switch. If the VPI or VCI for one of these control channels from another switch does not fall within the range for the called port, the called switch rejects the call.

To use this command, the port must be down (see **dnnpport**). The **maxsvccvpi** default of 4095 provides the maximum advantage for negotiation during ILMI auto-configuration. Note that the **maxsvccvpi** parameter is limited by the highest VPI that the switch assigns (whether the port is a UNI or an NNI).

In addition to the port ID, you must specify at least one keyword for **cnfnpportrange**.

Syntax

```
cnfnpportrange <portid> [-minsvccvpi min-svcc-vpi ] [-maxsvccvpi max-svcc-vpi ]
[-minsvccvci min-svcc-vci ] [-maxsvccvci max-svcc-vci ] [-minsvpcvpi min-svpc-vpi ]
[-maxsvpcvpi max-svpc-vpi ]
```

Syntax Description

<i>portid</i>	The format of the PNNI physical port identifier can vary, as follows: <ul style="list-style-type: none"> On a PXM45: <i>slot:subslot.port:subport</i> On a PXM1E for UNI/NNI back card: <i>slot:subslot.port:subport</i>. On the UNI/NNI back card, the subslot is always 2, but the <i>slot</i> depends on the chassis, as follows: <ul style="list-style-type: none"> In an MGX 8850 chassis, <i>slot</i> is always the logical slot 7. In an MGX 8830 chassis, <i>slot</i> is always the logical slot 1. On a PXM1E for a narrowband service module (NBSM): <i>slot.port</i>. For more details, see the section, “PNNI Format,” in Chapter 1, “Introduction.”
-minsvccvpi	The <i>min-svcc-vp</i> : minimum VPI for SVCC. Range: 0–4095 Default: 0
-maxsvccvpi	The <i>max-svcc-vp</i> : maximum VPI for SVCC. Range: 0–4095 Default: 4095
-minsvccvci	The <i>min-svcc-vci</i> : minimum VCI for SVCC. Range: 0–65535 Default: 35
-maxsvccvci	The <i>max-svcc-vci</i> : maximum VCI for SVCC. Range: 32–65535 Default: 65535

-minsvpcvpi	The <i>min-svpc-vp</i> : minimum VPI for SVPC. Range: 1–4095 Default: 1
-maxsvpcvpi	The <i>max-svpc-vp</i> : maximum VPI for SVPC. Range: 1–4095 Default: 4095

Related Commands

dsppnportrange

Attributes

Log: yes State: active Privilege: GROUP1

cnfnpnportsig

Configure Port Signaling—PXM45, PXM1E

The **cnfnpnportsig** command lets you specify ATM signaling parameters for a UNI, EVUNI, NNI, or EVNNI port. The port must be down for you to use this command. When a port is first created, its administrative state is down, in which case you do not need to down it. If the port is up, do the following:

1. De-activate the port by using the **dnnpnport** command.
2. Modify parameters as needed by using the **cnfnpnportsig** command.
3. Activate the port by using the **upnpnport** command.

The type of interface you specify on the controller must match the interface type that you configure on the slave (either a service module of the PXM1E UNI/NNI back card). On the slave side, specify UNI, NNI, or VNNI. On the controller card, the **cnfnpnportsig** command also has options for specifying the *version* of an interface type and other parameters that apply to signaling. See the Syntax Description.

A port can be non-signaling or capable of signaling. Only a UNI can be a non-signaling port and terminate SPVCs or SPVPs. A UNI does not necessarily require you to use the **cnfnpnportsig** command. However, if you need to specify a UNI *version*, use the **cnfnpnportsig** command for this purpose.

The non-signaling ports tend to be at the network edge. As the usage of a node gets closer to the core, more via nodes and NNI ports are configured, and more signaling ports are used. SVCs also require signaling ports. These variations affect the allotment of ports.

In the current release, the controller cards have different resources for maximum ports, as follows:

- The PXM45 supports a maximum of 192 logical or signaling ports on the node.
- The PXM45 can support 250,000 connections.
- The PXM1E supports a total of 4000 ports. Of this total, a maximum of 100 signaling ports are available. The reason for the greater number of ports is the anticipated large number of PVCs terminating on the legacy cards. The PXM1E supports up to 27,000 endpoints on its own UNI/NNI back card and 27,000 connections on the service modules. If all connection on the PXM1E are intended to go into IMA groups, the maximum number of connections on the PXM1E is 13,500.

Syntax

```
cnfnpnportsig <portid> [-univer {uni30 | uni31 | uni40 | q2931 | none | self}]
[-nniver {iisp30 | iisp31 | pnni10 | enni | aini}] [-unitype {public | private}]
[-addrplan {both | aesa | e164}] [-side {user | network}] [-vpi <vpi>] [-sigvci signalling-vci]
[-rcvcvci routing-vci] [-cntlvc {ip}] [-passalongcap {enable | disable}] [-hopcntgen {enable | disable}]
[-vpivcialloc {enable | disable}] [-svcroutingpri <priority> ]
```

Syntax Description

<i>portid</i>	<p>The format of the PNNI physical port identifier can vary, as follows:</p> <ul style="list-style-type: none"> • On a PXM45: <i>slot:subslot.port:subport</i> • On a PXM1E for UNI/NNI back card: <i>slot:subslot.port:subport</i>. On the UNI/NNI back card, the subslot is always 2, but the <i>slot</i> depends on the chassis, as follows: <ul style="list-style-type: none"> – In an MGX 8850 chassis, <i>slot</i> is always the logical slot 7. – In an MGX 8830 chassis, <i>slot</i> is always the logical slot 1. • On a PXM1E for a narrowband service module (NBSM): <i>slot.port</i>. <p>For more details, see the section, “PNNI Format,” in Chapter 1, “Introduction.”</p>
-univer	<p>UNI is the default for a new PNNI port, but no default <i>version</i> exists for UNI. The UNI version can be uni30, uni31, uni40, q2931, none, or self. Note that to change a UNI version, the port must be down. After configuration, up the port by using the upnpport command.</p> <p>The none choice applies to any port that does not need to run SSCOP protocol (for example, SPVC endpoints).</p> <p>The self choice applies to voice SVCs.</p> <p>Note that <i>univer</i> and <i>nniver</i> are mutually exclusive—so the interface at each end of the connection must have the same interface type. Also, the port type on the PNNI controller side must be the same as the slave (through addport ifType, for example).</p> <p>Default: no default</p>
-nniver	<p>The NNI version: iisp30, iisp31, pnni10, aini, or enni. Note that <i>univer</i> and <i>nniver</i> are mutually exclusive—so the interface at each end of the connection must have the same interface type. Also, the port type on the PNNI controller must be the same as on the slave (through addport ifType on the AXSM, for example).</p> <p>The default for this parameter is PNNI 1.0. If this version is sufficient, you can forego this parameter. However, to change an NNI version, the port must be down. Remember to up the port by using the upnpport command after completing the cnfnpportsig command.</p> <p>Default: no default</p>
-unitype	<p>The type of UNI is either private or public. This parameter is relevant only if you specified a UNI interface through the -univer parameter.</p> <p>Default: no default</p>
-addrplan	<p>The address plan of the calling party that the interface accepts. The choices are both, e164, and aesa. The default is both.</p> <p>Only a public UNI can use this parameter. For all other interface types, the port automatically accepts either AESA or E.164 address plans.</p>

-side	<p>For the side of the port, type user or network. When you set up PNNI signalling for IISP, one end must be <i>network</i> and one end must be <i>user</i>. If both sides are the same, a configuration error has occurred. This parameter applies to IISP only and public UNI. The network side is the side that assigns the VPI and VCI. (An NNI automatically is the network side.)</p> <p>See also the cnfenhiisp description for details about enhanced IISP.</p> <p>Note IISP links do not distinguish between SVCs and SPVCs.</p> <p>Default: network</p>
-vpi	<p>The VPI of the signaling and routing control channel (RCC) on the port.</p> <p>Range: 0–4095 Default: 0</p>
-sigvci	<p>The signaling VCI for the port. If you do not use the default of 5, this VCI must be in the range 32–65535.</p> <p>Range: 5 or 32–65535 Default: 5</p>
-rccvci	<p>The <i>routing control channel-vci</i>: the VCI for PNNI RCC. If you do not use the default of 18, this VCI must be in the range 32–65535.</p> <p>Range: 18 or 32–65535 Default: 18</p>
-cntlvc	<p>Enable for an IP-based signaling channel. This option applies only to a feeder connected to the switch. An IP-based control channel is mutually exclusive of either UNI or NNI. The only choice for -cntlvc is “ip.”</p> <p>Default: “ip” (for Internet Protocol)</p>
-passalongcap	<p>Pass-along capability: type “enable” or “disable.” With this capability, the port has the ability to pass along unrecognized information elements (IEs) or messages. Enabling or disabling the pass-along capability applies to AINI, IISP, and public UNI. For all other types, the port behaves as if pass-along is enabled—you cannot disable pass-along on the other port types.</p> <p>Default: enable</p>
-hopcntgen	<p>This parameter applies to AINI only. Type the entire word, “enable” or “disable.” If you enable hop counting for AINI, the controller generates the hop counter information IE for all setup messages that pass through the interface if this IE does not already exist in the setup message. You must also enable AINI hop count IE for the switch by using the cnfainihopcount command.</p> <p>Default: enable</p>

-vpivcialloc	<p>This parameter applies to AINI: type “enable” or “disable.” If you enable it, the interface becomes responsible for assigning the VPI and VCI for all connections.</p> <p>Note that if you enable VPI/VCI allocation on one side of the AINI link, allocation must be disabled on the other side of the link,</p> <p>Default: enable</p>
---------------------	---

-svcroutingpri	<p>The -svcroutingpri option lets you specify a default routing priority for a port. This parameter becomes relevant when a setup message for an SVC or SPVC arrives with no PSIE at a node that supports priority routing. For example, the PSIE may have been dropped at a via node that does not support priority routing. In such a situation, the value for svcroutingpri becomes the routing priority for the connection. See the cnfpri-routing description for details on priority routing.</p> <p>The routing priority is used during de-routing. SVCs and SPVCs are released according to the routing priority. This release prioritization promotes faster re-routing of higher priority connections.</p> <p>Range: 1–15</p> <p>Default: 8</p>
-----------------------	--

Related Commands

dsppnportsig

Attributes

Log: yes State: active Privilege: GROUP1

Examples

Specify an RCC VCI of 10000 for port 1:2.1:1. Be sure the interface type is compatible with the parameter you want to change. Do the following:

1. Confirm that the interface type for 1:2.1:1 is NNI.
2. Down the port.
3. Configure the RCC VCI to be 10000.
4. Check the port by using the **dsppnportsig** command.
5. Up the port.

```
M8850_NY.7.PXM.a > dsppnport 1:2.1:1
```

```

Port:                1:2.1:1                Logical ID:          16848897
IF status:           up                      Admin Status:       up
UCSM:               enable
Auto-config:        enable                  Addr-reg:           enable
IF-side:            network                  IF-type:            nni
UniType:            private                  Version:            pnni10
PassAlongCapab:     n/a
Input filter:       0                        Output filter:      0
minSvccVpi:         0                        maxSvccVpi:        200
minSvccVci:         35                       maxSvccVci:        255
minSvpcVpi:         1                        maxSvpcVpi:        200

```

```

        #SpvcCfg: #SpvcActive: #SpvpCfg: #SpvpActive:
p2p : 0          0          0          0
p2mp: 0          0          0          0
        #Svcc:   #Svpc:     Total:
p2p : 0          0          0
p2mp: 0          0          0
                        Total:    0

```

```
M8850_NY.7.PXM.a > dnppnport 1:2.1:1
```

```
M8850_NY.7.PXM.a > cnfnpnportsig 1:2.1:1 -rccvci 10000
```

```
M8850_NY.7.PXM.a > dsppnportsig 1:2.1:1
```

```

provisioned IF-type: nni   version:   pnni10
sigType: private         side:      network
addrPlan: aesa
VpiVciAllocator: n/a     HopCounterGen: n/a
PassAlongCapab: n/a
sigVpi: 0                sigVci:    5
rccVpi: 0                rccVci:   10000

```

```
M8850_NY.7.PXM.a > uppnport 1:2.1:1
```

Take the following steps on a PXM1E for an initial configuration (assume the line has been upped):

1. Use the **addport** command to create logical port 2.2 on the slave side and make it an NNI.
2. Add a resource partition.
3. Add the PNNI port by using the **addpnport** command. The port ID is 7:2.2:2 because the slot is 7 in an MGX 8850 chassis with a PXM1E, and the subslot is always 2 for the same reason.
4. Display PNNI port. The state is down—the default.
5. Display PNNI port signaling by using the **dsppnportsig** command. At this stage, note the default interface type is UNI with no UNI version. This PNNI side default of UNI conflicts with the slave side configuration of an NNI for port 2, so you need to configure the PNNI port for NNI.
6. Use the **cnfnpnportsig** command to specify an NNI port with a version of PNNI 1.0.
7. Display the signaling for the port.
8. Up the PNNI port by using the **uppnport** command then display it.

```
PXM1E_SJ.7.PXM.a > addport 2 2.2 10000 10000 0 2
```

```
PXM1E_SJ.7.PXM.a > addpart 2 2 5 10000 10000 10000 10000 110 220 2000 4000 100 100
```

```
PXM1E_SJ.7.PXM.a > addpnport 7:2.2:2
```

```
PXM1E_SJ.7.PXM.a > dsppnport 7:2.2:2
```

```

Port:                7:2.2:2           Logical ID:          n/a
IF status:           provisioning       Admin Status:        down
VSVD Internal Loop: unspecified
VSVD External Loop: unspecified

```

```
PXM1E_SJ.7.PXM.a > dsppnportsig 7:2.2:2
```

```
provisioned IF-type: uni   version:   none
sigType: private         side:      network
addrPlan: aesa
VpiVciAllocator: n/a     HopCounterGen: n/a
PassAlongCapab: n/a
sigVpi: 0                sigVci:    5
rccVpi: n/a              rccVci:   n/a
svc routing priority: 8
```

```
PXM1E_SJ.7.PXM.a > cnfnpnportsig 7:2.2:2 -nniver pnni10
```

```
PXM1E_SJ.7.PXM.a > dsppnportsig 7:2.2:2
```

```
provisioned IF-type: nni   version:   pnni10
sigType: private         side:      network
addrPlan: aesa
VpiVciAllocator: n/a     HopCounterGen: n/a
PassAlongCapab: n/a
sigVpi: 0                sigVci:    5
rccVpi: 0                rccVci:   18
svc routing priority: 8
```

```
PXM1E_SJ.7.PXM.a > uppnport 7:2.2:2
```

```
PXM1E_SJ.7.PXM.a > dsppnport 7:2.2:2
```

```
Port: 7:2.2:2           Logical ID: n/a
IF status: provisioning Admin Status: up
```

cnfpnstat

Configure PNNI Statistics—PXM45, PXM1E

The **cnfpnstat** command configures SPVC and SPVP statistics collation. Its application is to regulate the availability of node-based or interface-based statistics to Cisco WAN Manager. The applicable statistics appear in [Table 2-12](#). This table also shows whether the statistics are node-based or interface-based.

Table 2-12 PNNI SPVC and SPVP Statistics

Statistic	Interface/Nodal
Number of successful SPVC and SPVP call attempts for a port on an originating node	Interface-based
Number of unsuccessful SPVC and SPVP call attempts for a port on an originating node	Interface-based
Number of SPVC and SPVP crankbacks directed to (or received by) a port on an originating node (these crankbacks are release messages received on a port)	Interface-based
Number of successful SPVC and SPVP call attempts for a port on an entry border node	Interface-based
Number of unsuccessful SPVC and SPVP call attempts for a port on an entry border node	Interface-based
Number of SPVC and SPVP crankbacks directed to a port on an entry border node (these crankbacks are release messages received on this port)	Interface-based
Number of SPVC and SPVP crankbacks initiated by a port on a node (these crankbacks are release messages generated by this port)	Interface-based
Number of successful re-routes of SPVCs and SPVPs	Nodal-based
Number of unsuccessful re-routes of SPVCs and SPVPs	Nodal-based

Syntax

```
cnfpnstat {[-feat {enable | disable}] [-ndlstats {enable | disable}]
[-allintfstats {enable | disable | as-per-each-intf-cfg}] |
[-intfstats {enable | disable} -port <portid>]}
```

Syntax Description

You must specify at least one parameter.

-feat	This parameter enables or disables PNNI bulk statistics availability for CWM. If this parameter is disabled, no PNNI statistics are not written to the bulk statistics file that CWM reads. For the remaining parameters to have any meaning, this parameter must be enabled. Type the word “enable” or “disable.” Default: disabled
-ndlstats	This option enables or disables the node-based statistics collection. (See Table 2-12 for the node-based statistics.) For node-level stats to be available to the bulk stats file, -feat must be enabled. Default: disable

-allintfstats	<p>This option provides an easy way to enable or disable interface-based statistics collection on all ports. (See Table 2-12 for the interface-based statistics.) If this parameter remains disabled, none of the interface-based statistics become available to CWM. Note that if the -allintfstats value is “enable,” this enable overrides the per interface enable of the -intfstats parameter. The keyword value “as-per-each-intf-cfg” means that the interface-based statistics are made available based on the configuration for each interface. The -feat parameter must be enabled for this parameter to have any effect.</p> <p>Possible entries: enable, disable, as-per-each-intf-cnf</p> <p>Default: as-per-each-intf-cnf</p>
-intfstats	<p>This option enables or disables the collection of statistics per port. If you enable it, you should also provide a PNNI physical port ID. (See Table 2-12 for the interface-based statistics.) Note that -feat must be enabled for this parameter to have any effect.</p> <p>Possible entries: disable, enable, and a port ID</p> <p>Default: disable</p>

Related Commands

dsppnstat

Attributes

Log: yes State: active Privilege: GROUP1

Examples

Enable PNNI statistics.

```
PXM1E_SJ.7.PXM.a > cnfnpstat -feat enable
```

Enable node-based PNNI statistics.

```
PXM1E_SJ.7.PXM.a > cnfnpstat -ndlstats enable
```

Disable interface-based PNNI statistics on port 1:1.2:2.

```
PXM1E_SJ.7.PXM.a > cnfnpstat -intfstats disable -portid 1:1.2:2
```

Enable interface-based statistics collection based on the per-interface configuration.

```
PXM1E_SJ.7.PXM.a > cnfnpstat -allintfstats as-per-intf-cfg
```