



CHAPTER 4

Maintenance and Upgrade Procedures

This chapter describes how to, remove and replace the chassis cover, the power supply, and the CompactFlash. This chapter includes the following sections:

- [Removing and Replacing the Chassis Cover, page 4-1](#)
- [Working in an ESD Environment, page 4-3](#)
- [Removing and Replacing a Lithium Battery in the SSM, page 4-4](#)
- [Removing and Replacing the Power Supply, page 4-4](#)
- [Installing the DC Model, page 4-7](#)
- [Removing and Replacing the CompactFlash, page 4-10](#)
- [Installing and Replacing the 4GE SSM, page 4-14](#)
- [Installing and Replacing the Intelligent SSM, page 4-20](#)
- [Upgrading Memory in the Adaptive Security Appliance, page 4-23](#)

Removing and Replacing the Chassis Cover

This section describes how to remove and replace the chassis cover. This section includes the following topics:

- [Removing the Chassis Cover, page 4-1](#)
- [Replacing the Chassis Cover, page 4-2s](#)

Removing the Chassis Cover

To remove the chassis cover, perform the following steps:

**Note**

Removing the chassis cover does not affect Cisco warranty. Upgrading the adaptive security appliance does not require any special tools and does not create any radio frequency leaks.

- Step 1** Read the *Regulatory Compliance and Safety Information for the Cisco ASA 5500 Series* document.
- Step 2** Power off the adaptive security appliance. Once the upgrade is complete, you can safely power on the chassis.

**Warning**

Before working on a system that has an On/Off switch, turn OFF the power and unplug the power cord.
Statement 1

Step 3 Remove the screws from the top of the chassis (Figure 4-1).

Figure 4-1 Removing the Top Panel Screws

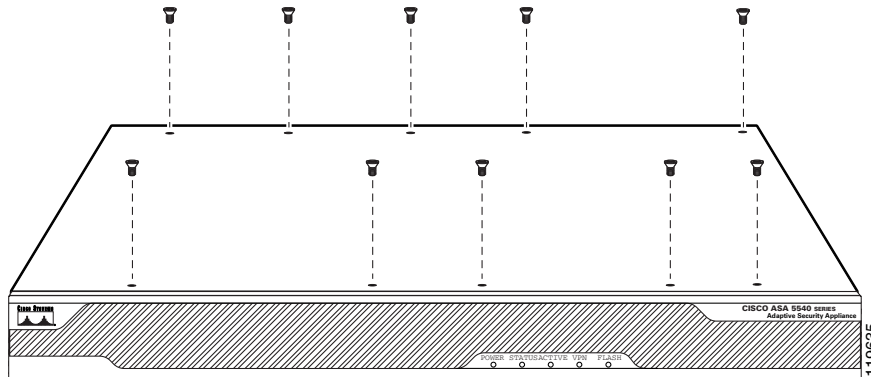

Step 4 Pull the top panel up as shown in Figure 4-2. Put the panel in a safe place.

Figure 4-2 Removing the Chassis Cover

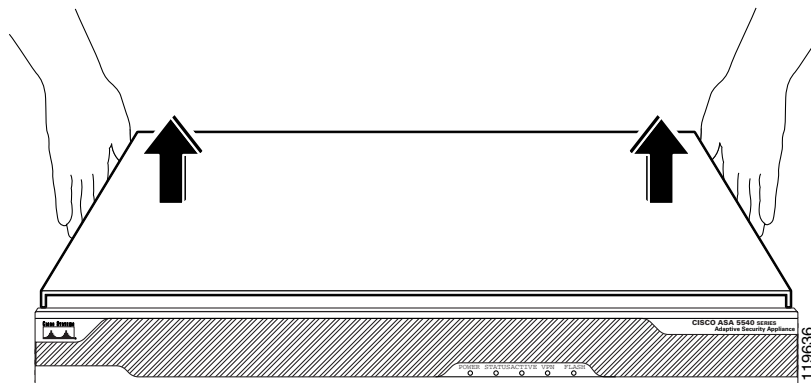

Replacing the Chassis Cover

**Caution**

Do not operate the adaptive security appliance without the chassis cover installed. The chassis cover protects the internal components, prevents electrical shorts, and provides proper air-flow for cooling the electronic components.

To replace the chassis cover, perform the following steps:

Step 1 Place the chassis on a secure surface with the front panel facing you.

- Step 2** Hold the top panel so the tabs at the rear of the top panel are aligned with the chassis bottom.
- Step 3** Lower the front of the top panel onto the chassis as shown in [Figure 4-3](#).

Figure 4-3 Replacing the Chassis Cover

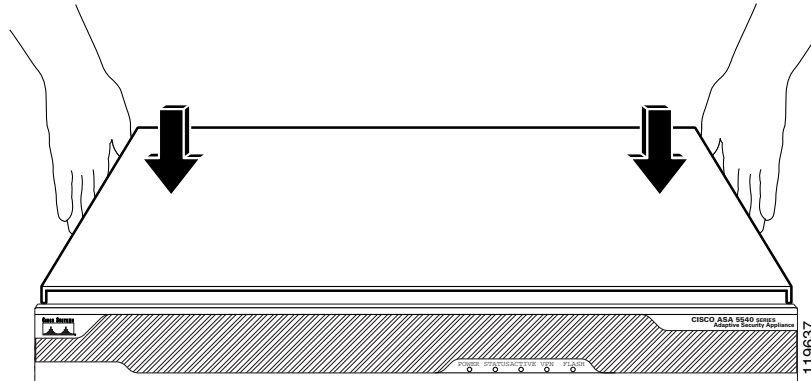

- Step 4** Fasten the top panel with the screws you set aside earlier as shown in [Figure 4-4](#).

Figure 4-4 Replacing the Screws

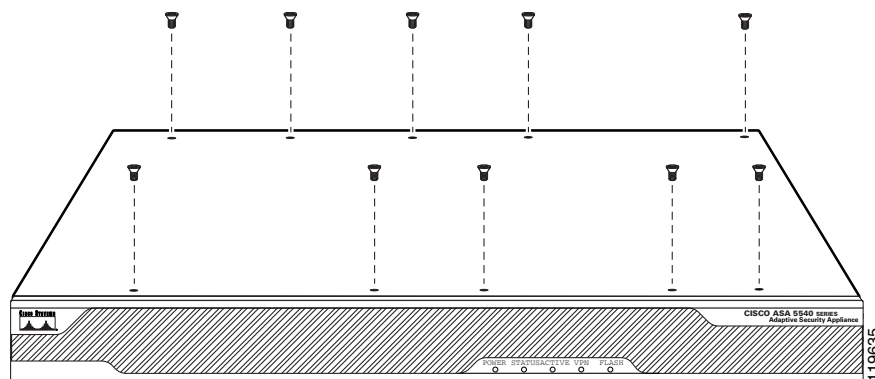

- Step 5** Reinstall the chassis on a rack.
- Step 6** Reinstall the network interface cables.

Working in an ESD Environment

Electrostatic discharge (ESD) can damage equipment and impair electrical circuitry. ESD damage occurs when electronic components are improperly handled and can result in complete or intermittent failures. Always follow ESD-prevention procedures when you remove and replace components. Ensure that the chassis is electrically connected to earth ground. Wear an ESD-preventive wrist strap, ensuring that it makes good skin contact. Connect the grounding clip to an unpainted surface of the chassis frame to safely ground unwanted ESD voltages. To guard against ESD damage and shocks, the wrist strap and cord must operate properly. If no wrist strap is available, ground yourself by touching the metal part of the chassis.

Removing and Replacing a Lithium Battery in the SSM

To remove and replace the battery in the SSM, perform the following steps:

-
- Step 1** Remove the two screws at the left rear end of the chassis, and remove the slot cover as described in “Installing and Replacing the Intelligent SSM” section on page 4-20.
 - Step 2** Slide the metal clip back and pull the battery out.
 - Step 3** Place the used battery aside.
 - Step 4** Replace the battery with a compactible Lithium CR-2032 battery (which is available at your local electronics or drug store), by sliding the metal clip back and sliding the battery into place.
 - Step 5** Replace the chassis cover as described in the “Installing and Replacing the Intelligent SSM” section on page 4-20.
-

Removing and Replacing the Power Supply

For information on power supply considerations including environmental operating ranges and power requirements, see table 7 at the following url:

http://www.cisco.com/en/US/prod/collateral/vpndevc/ps6032/ps6094/ps6120/product_data_sheet0900aec802930c5.html

For information on AC-input power cord options, see Table 2-1 in the “Power Supply Considerations” section on page 2-4

This section describes how to remove and replace the power supply, and includes the following topics:

- [Removing the AC Power Supply, page 4-4](#)
- [Replacing the AC Power Supply, page 4-6](#)

Removing the AC Power Supply

To remove the AC power supply, perform the following steps:

-
- Step 1** Power off the adaptive security appliance.
 - Step 2** Remove the power cord and all other cables from the chassis.
 - Step 3** Remove the chassis from the rack if it is rack-mounted.
 - Step 4** Remove the chassis cover. See the “Installing and Replacing the Intelligent SSM” section on page 4-20 for more information.
 - Step 5** Place the chassis in an ESD-controlled environment. See the “Working in an ESD Environment” section on page 4-3 for more information.

- Step 6** Lift the rear of the chassis from the surface and unscrew both the screws that secures the power supply to the chassis, as shown in [Figure 4-5](#).

Figure 4-5 Removing the Power Supply Screws

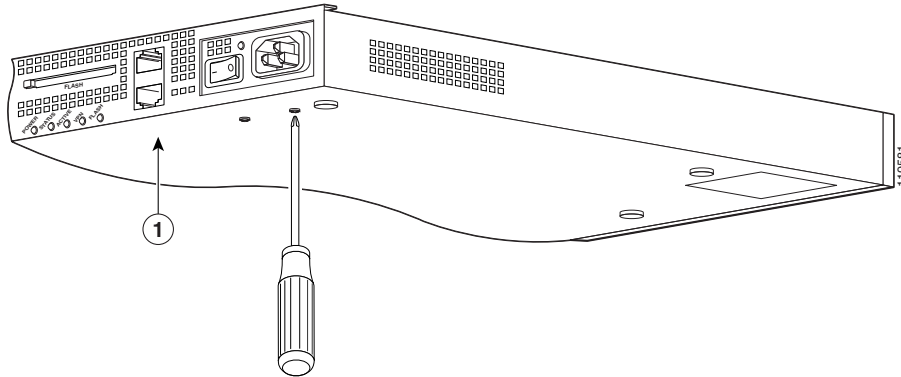

1	Chassis bottom
----------	----------------

- Step 7** Locate the power connector on the system board.
- Step 8** Unlatch the plug, then grasp the sides of the power connector and pull upward while rocking the connector from side to side. Disconnect the power connector from the system board as shown in [Figure 4-6](#).

Figure 4-6 Disconnecting the Power Connector

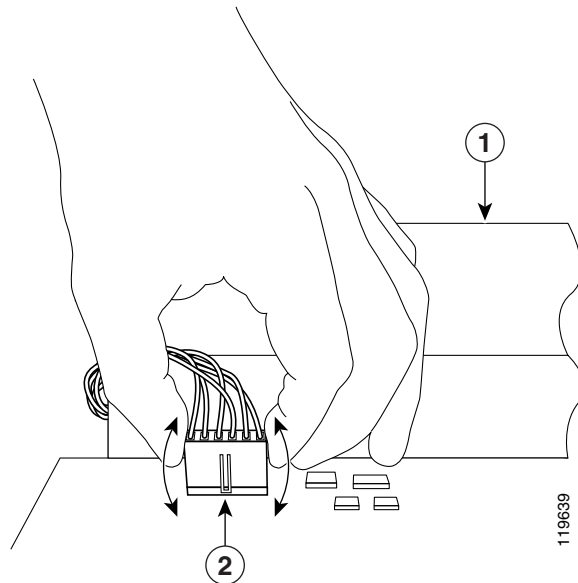

1	AC power supply	2	Power connector
----------	-----------------	----------	-----------------

Step 9 Remove the power supply brace by pulling it up and then out as shown in [Figure 4-7](#).

Figure 4-7 Removing the Power Supply

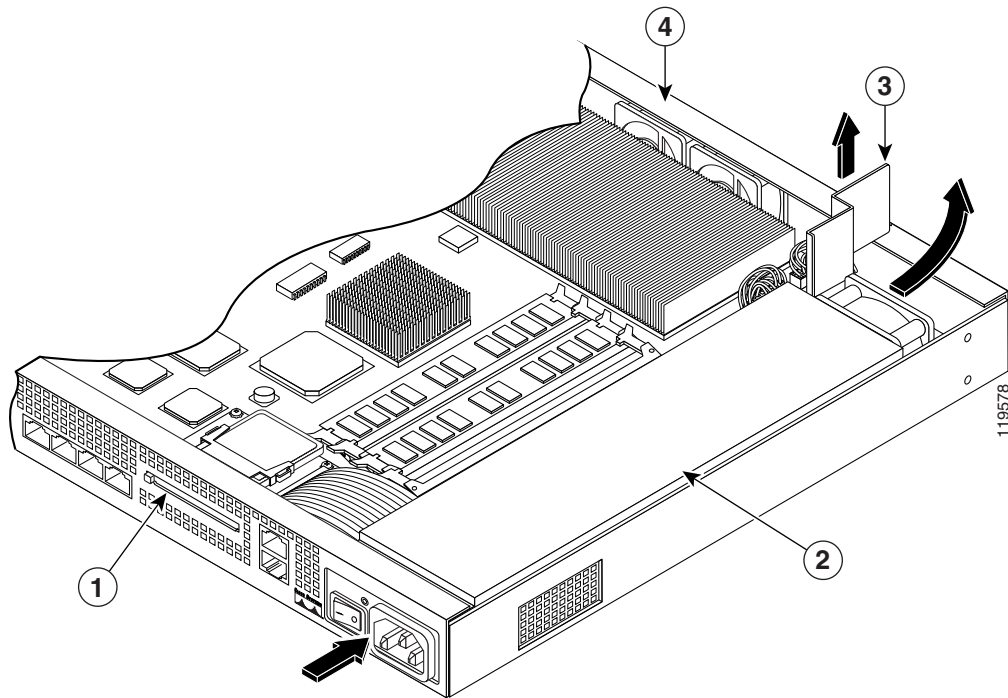

1	Back panel	3	Power supply brace
2	Power supply	4	Front panel

Step 10 From the back of the chassis, push the power supply forward, and then lift it up and out.

Replacing the AC Power Supply

To replace the AC power supply, perform the following steps:

- Step 1** Insert the new power supply into place and slide it towards the back of the adaptive adaptive security appliance.
- Step 2** Lift the rear of the adaptive adaptive security appliance from the surface and reinstall both screws.

Step 3 Insert the power supply brace and press down until it fits into place, as shown in [Figure 4-8](#).

Figure 4-8 Replacing the Power Supply Brace and the AC Power Supply

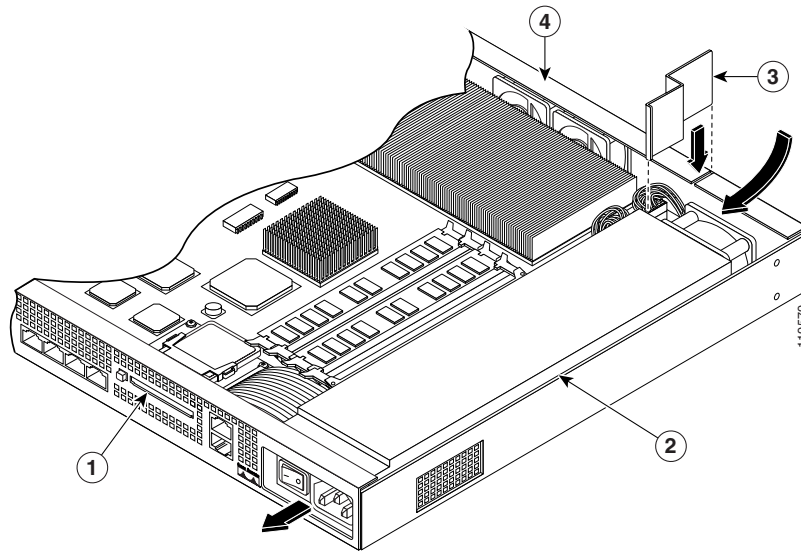

1	Back panel	3	Power supply brace
2	Power supply	4	Front panel

Step 4 Connect the power connector to the system board.

Step 5 Replace the adaptive adaptive security appliance cover. See [“Replacing the Chassis Cover”](#) for more information.

Step 6 Reinstall the network interface cables.

Installing the DC Model



Warning

Before performing any of the following procedures, ensure that power is removed from the DC circuit. To ensure that all power is OFF, locate the circuit breaker on the panel board that services the DC circuit, switch the circuit breaker to the OFF position, and tape the switch handle of the circuit breaker in the OFF position. Statement 7



Note

The DC return connection should remain isolated from the system frame and chassis (DC-I). This equipment is suitable for connection to intra-building wiring only.

To install the DC power model, perform the following steps:

- Step 1** Read the *Regulatory Compliance and Safety Information for the Cisco ASA 5500 Series* document.
- Step 2** Terminate the DC input wiring on a DC source capable of supplying at least 15 amps. A 15-amp circuit breaker is required at the 48 VDC facility power source. An easily accessible disconnect device should be incorporated into the facility wiring.
- Step 3** Locate the DC-input terminal box, see [Figure 4-9](#).

Figure 4-9 DC-Input Terminal Box

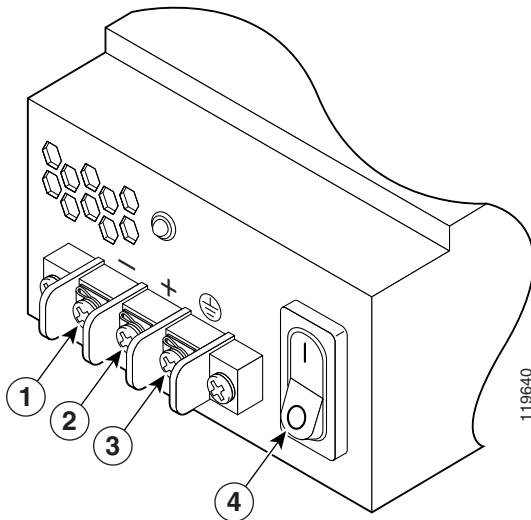

1	Negative	3	Ground
2	Positive	4	On/Off switch

- Step 4** Power off the adaptive security appliance. Ensure that power is removed from the DC circuit. To ensure that all power is OFF, locate the circuit breaker on the panel board that services the DC circuit, switch the circuit breaker to the OFF position, and tape the switch handle of the circuit breaker in the OFF position.
- Step 5** Remove the DC power supply plastic shield.
- Step 6** The adaptive security appliance is equipped with two grounding holes at the side of the chassis, which you can use to connect a two-hole grounding lug to the adaptive security appliance. Use 8-32 screws to connect a copper standard barrel grounding lug to the holes. The adaptive security appliance requires a lug where the distance between the center of each hole is 0.56 inches. A lug is not supplied with the adaptive security appliance.
- Step 7** Strip the ends of the wires for insertion into the power connect lugs on the adaptive security appliance.

- Step 8** Insert the ground wire into the connector for the earth ground and tighten the screw on the connector. See [Figure 4-10](#), and using the same method as for the ground wire, connect the negative wire and then the positive wire.



Note The DC return connection to this system is to remain isolated from the system frame and chassis.

Figure 4-10 DC-Input Power Supply Connections

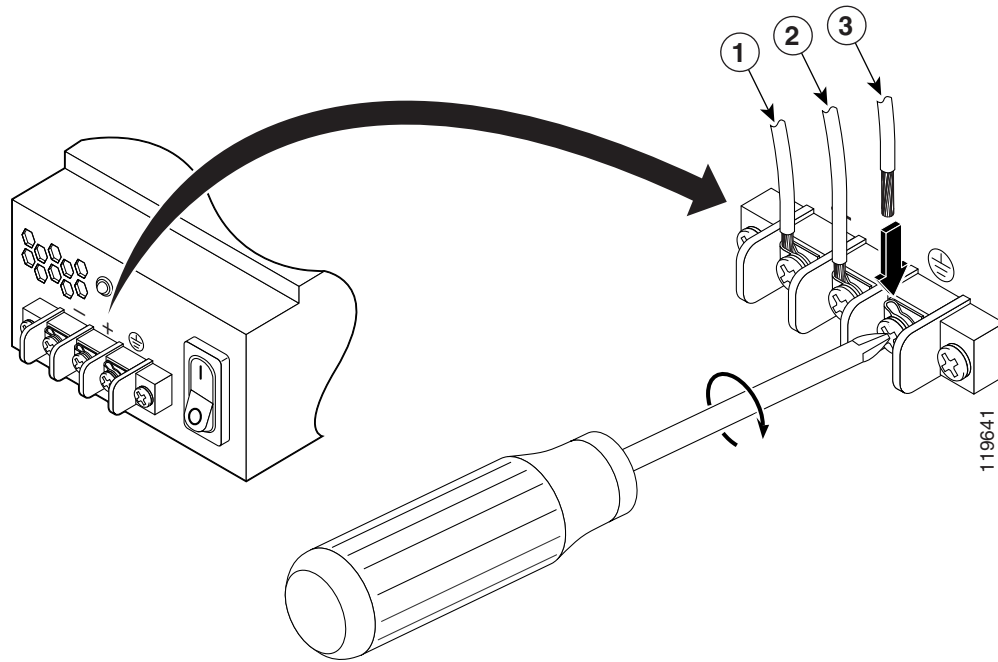

1	Negative	3	Ground
2	Positive		

- Step 9** After wiring the DC power supply, remove the tape from the circuit breaker switch handle and reinstate power by moving the handle of the circuit breaker to the ON position.
- Step 10** Install any remaining interface boards as described in [“Installing the DC Model”](#) section on page 4-7.
- Step 11** Replace the DC power supply plastic shield.
- Step 12** Power on the adaptive security appliance from the switch at the rear of the chassis.



Note If you need to power cycle the DC adaptive security appliance, wait at least 5 seconds between powering off the adaptive security appliance and powering it back on.

Removing and Replacing the CompactFlash

The adaptive security appliance has two types of CompactFlash: the system CompactFlash (internal) and the user CompactFlash (external). This section includes the following topics:

- [Removing and Installing the System CompactFlash, page 4-10](#)
- [Removing and Installing the User CompactFlash, page 4-12](#)

Removing and Installing the System CompactFlash

To remove and install the system CompactFlash, perform the following steps:

-
- Step 1** Power off the adaptive security appliance.
 - Step 2** Remove the power cord and other cables from the adaptive security appliance.
 - Step 3** Remove the adaptive security appliance from the rack if it is rack-mounted.
 - Step 4** Place the adaptive security appliance in an ESD-controlled environment.
 - Step 5** Remove the adaptive security appliance cover.
 - Step 6** Carefully slide the CompactFlash out of its connector as shown in [Figure 4-11](#). The CompactFlash has a lip on its lower edge, which you can use to grip the CompactFlash. Otherwise, use sliding pressure with your thumb or finger to slide the CompactFlash out of its connector.

Figure 4-11 Removing the System CompactFlash

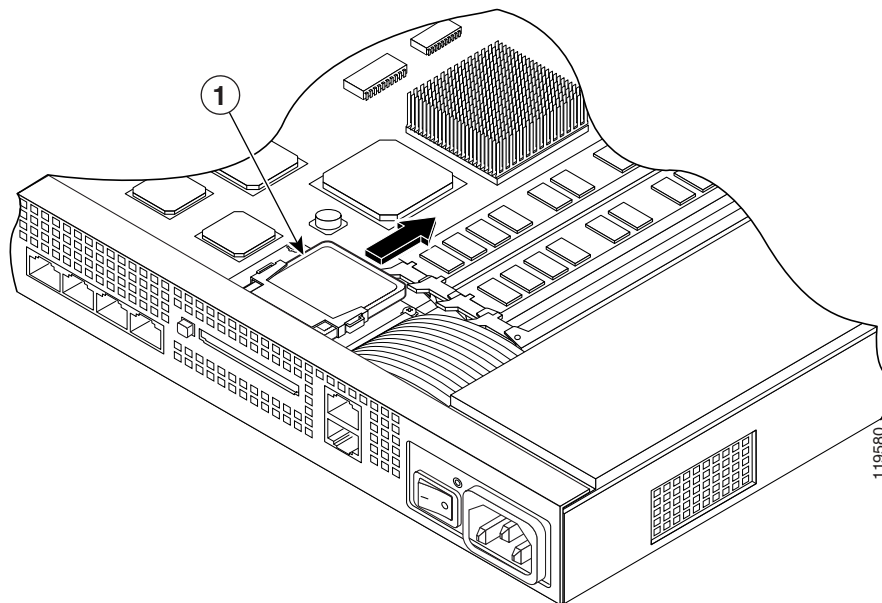

1	System CompactFlash
----------	---------------------

- Step 7** To install the system CompactFlash, align the new system CompactFlash with the connector on the riser card.
- Step 8** Push the system CompactFlash inward until it is fully seated in the connector, see [Figure 4-12](#).

Figure 4-12 Replacing the System CompactFlash

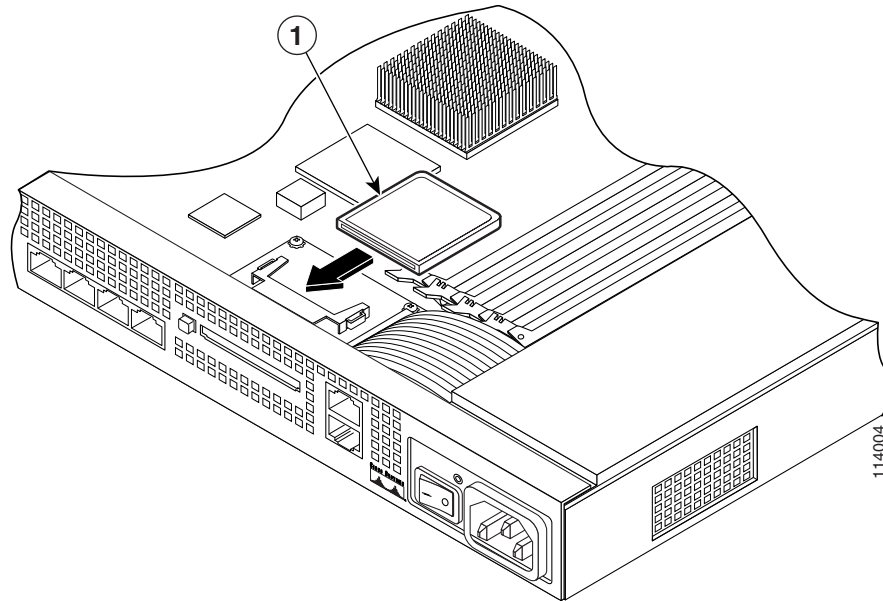

1	System CompactFlash
---	---------------------

- Step 9** Replace the adaptive security appliance cover.
- Step 10** Reinstall the network interface cables.
-

Removing and Installing the User CompactFlash

To remove and install the user CompactFlash, perform the following steps:



Note

There are two types of CompactFlash release buttons. The release buttons function differently. In this document we refer to them as Type A and Type B.

Step 1 Locate the user CompactFlash in its slot in the rear panel of the chassis. See [Figure 4-13](#).

Figure 4-13 User CompactFlash and Release Button Location—Type A and B

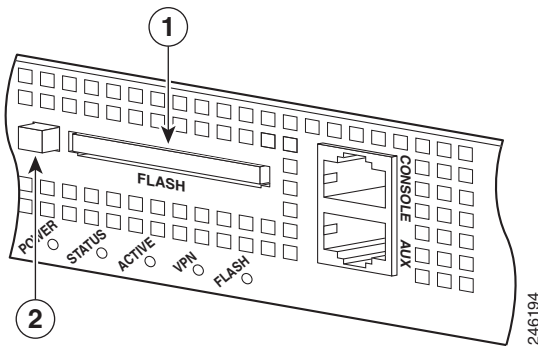

1	User CompactFlash in the slot	2	Release button extended
----------	-------------------------------	----------	-------------------------

Step 2 Press the release button, the release button in Type A will pop out towards you. See [Figure 4-14](#).

In Type B pressing the release button once will eject the CompactFlash, the release button will be slightly extended. See [Figure 4-15](#). If this is the case, skip Step 3 and go to [Step 4](#).

Figure 4-14 Release Button Fully Extended—Type A

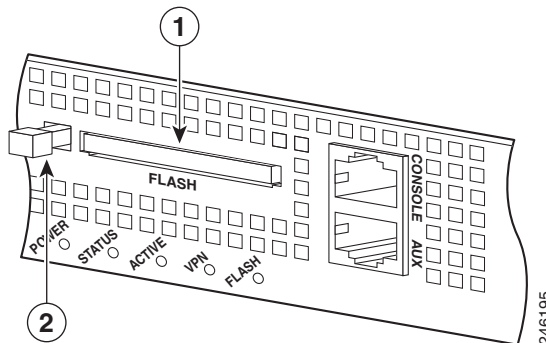

1	User CompactFlash in the slot	2	Release button fully extended
----------	-------------------------------	----------	-------------------------------

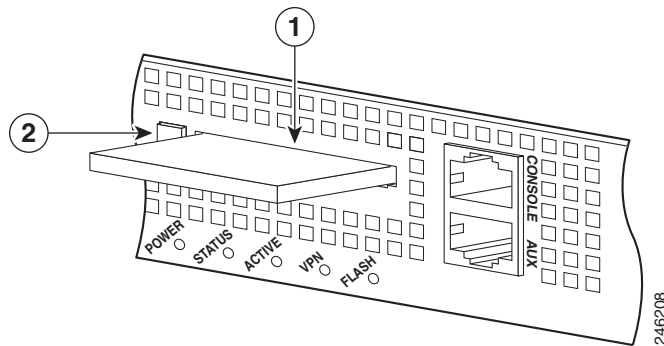
Figure 4-15 User CompactFlash and Release Button Slightly Extended—Type B

1	User CompactFlash	2	Release button slightly extended
----------	-------------------	----------	----------------------------------

Step 3 Press the release button again, the CompactFlash will eject and the release button will be extended. See [Figure 4-16](#).

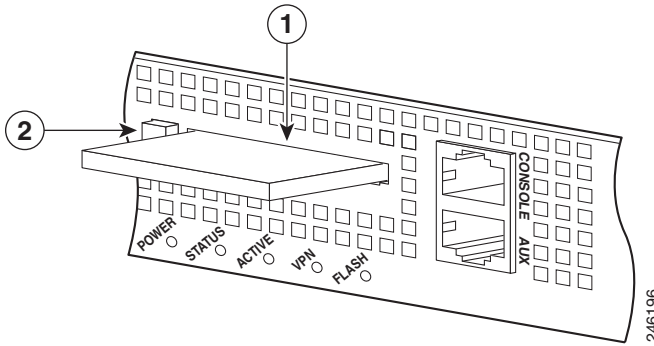
Figure 4-16 User CompactFlash and Release Button Extended—Type A

1	User CompactFlash	2	Release button extended
----------	-------------------	----------	-------------------------

Step 4 Carefully pull the user CompactFlash out of the slot.



Note When the User CompactFlash slot is empty, the release button on Type A, see [Figure 4-16](#) will be extended and in Type B, see [Figure 4-15](#) the release button will be slightly extended.

Step 5 Place the removed user CompactFlash on an antistatic surface or in a static shielding bag.

Step 6 To install a new CompactFlash, hold the new CompactFlash with the label facing up, insert the connector end of the user CompactFlash into the slot until the card is seated in the connector. The user CompactFlash is keyed so it cannot be inserted the wrong way.

The release button will remain extended when you insert the CompactFlash see [Figure 4-13](#).

Installing and Replacing the 4GE SSM

The 4GE SSM has four 10/100/1000 Mbps, copper, RJ-45 ports and four optional 1000 Mbps, Small-Form-Factor Pluggable (SFP) fiber ports.



Note

When using the 4GE SSM you can use the same numbered copper ports (RJ-45) and the SFP ports at the same time. Use the **media-type** command in interface configuration mode to set the media type to copper or fiber Gigabit Ethernet. For a complete description of the command syntax, see the *Cisco ASA 5500 Series Command Reference*.

This section describes how to install and replace the 4GE SSM in the adaptive security appliance, and includes the following topics:

- [Overview, page 4-14](#)
- [Installing the 4GE SSM, page 4-15](#)
- [Replacing the 4GE SSM, page 4-16](#)
- [Installing and Removing the SFP Modules, page 4-16](#)

Overview

Figure 4-17 lists the 4GE SSM ports and LEDs.

Figure 4-17 4GE SSM Ports and LEDs

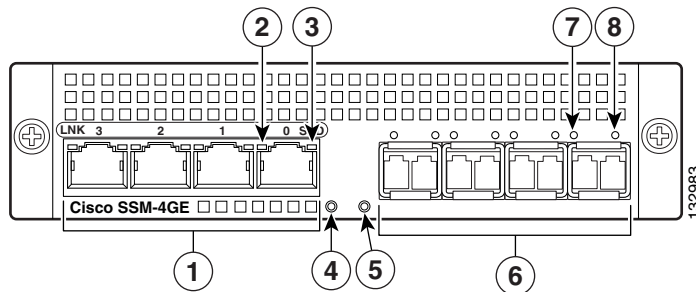

1	RJ-45 ports	5	Status LED
2	RJ-45 Link LED	6	SFP ports
3	RJ-45 Speed LED	7	SFP Link LED
4	Power LED	8	SFP Speed LED



Note

Figure 4-17 shows SFP modules installed in the ports slots. You must order and install the SFP modules if you want to use this feature. For more information on SFP ports and modules, see the “[Installing and Removing the SFP Modules](#)” section on page 4-16.

Table 4-1 describes the 4GE SSM LEDs.

Table 4-1 4GE SSM LEDs

	LED	Color	State	Description
2, 7	LINK	Green	Solid	There is an Ethernet link.
			Flashing	There is Ethernet activity.
3, 8	SPEED	Off	10 MB	There is no network activity.
		Green	100 MB	There is network activity at 100 Mbps.
		Amber	1000 MB (GigE)	There is network activity at 1000 Mbps.
4	POWER	Green	On	The system has power.
5	STATUS	Green	Flashing	The system is booting.
		Green	Solid	The system booted correctly.
		Amber	Solid	The system diagnostics failed.

Installing the 4GE SSM

To install a new 4GE SSM for the first time, perform the following steps:

-
- Step 1** Power off the adaptive security appliance.
 - Step 2** Locate the grounding strap from the accessory kit and fasten it to your wrist so that it contacts your bare skin. Attach the other end to the chassis.
 - Step 3** Remove the two screws (as shown in [Figure 4-18](#)) at the left rear end of the chassis, and remove the slot cover.

Figure 4-18 Removing the Screws from the Slot Cover

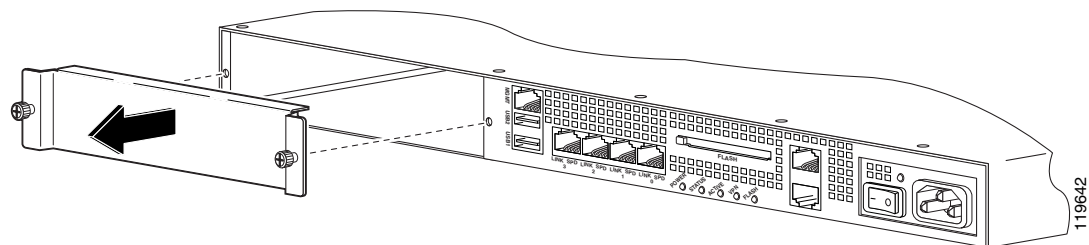

- Step 4** Insert the 4GE SSM through the slot opening as shown in [Figure 4-19](#).

Figure 4-19 Inserting the 4GE SSM into the Slot

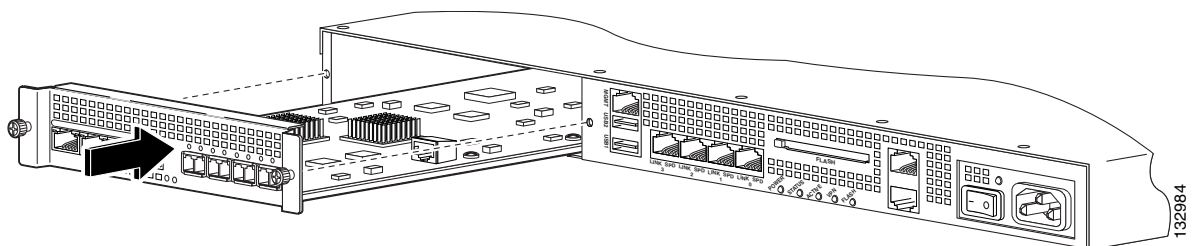

- Step 5** Attach the screws to secure the 4GE SSM to the chassis.
 - Step 6** Power on the adaptive security appliance.
 - Step 7** Check the LEDs. If the 4GE SSM is installed properly the STATUS LED flashes during boot up and is solid when operational.
 - Step 8** Connect one end of the RJ-45 cable to the port and the other end of the cable to your network devices.
-

Replacing the 4GE SSM

To replace an existing 4GE SSM, perform the following steps:

-
- Step 1** Power off the adaptive security appliance.
 - Step 2** Locate the grounding strap from the accessory kit and fasten it to your wrist, so that it contacts your bare skin. Attach the other end to the chassis.
 - Step 3** Remove the two screws at the left rear end of the chassis.
 - Step 4** Remove the 4GE SSM. Place it in a static bag and set it aside.
 - Step 5** Replace the existing card by inserting the new 4GE SSM through the slot opening.
 - Step 6** Attach the screws to secure the 4GE SSM to the chassis.
 - Step 7** Power on the adaptive security appliance.
 - Step 8** Check the LEDs. If the 4GE SSM is installed properly, the POWER LED is solid green and the STATUS LED is flashing during boot up.
 - Step 9** Connect the RJ-45 cable to the port and the other end of the cable to your network devices.
-

Installing and Removing the SFP Modules

The SFP is a hot-swappable input/output device that plugs into the SFP ports. The following SFP module types are supported:

- Long wavelength/long haul 1000BASE-LX/LH (GLC-LH-SM=)
- Short wavelength 1000BASE-SX (GLC-SX-MM=)

This section describes how to install and remove the SFP modules in the adaptive security appliance to provide optical Gigabit Ethernet connectivity. It contains the following topics:

- [SFP Module, page 4-16](#)
- [Installing the SFP Module, page 4-18](#)
- [Removing the SFP Module, page 4-19](#)

SFP Module

The adaptive security appliance uses a field-replaceable SFP module to establish Gigabit connections.

[Table 4-2](#) lists the SFP modules that are supported by the adaptive security appliance.

Table 4-2 Supported SFP Modules

SFP Module	Type of Connection	Cisco Part Number
1000BASE-LX/LH	Fiber-optic	GLC-LH-SM=
1000BASE-SX	Fiber-optic	GLC-SX-MM=

The 1000BASE-LX/LH and 1000BASE-SX SFP modules are used to establish fiber-optic connections. Use fiber-optic cables with LC connectors to connect to an SFP module. The SFP modules support 850 to 1550 nm nominal wavelengths. The cables must not exceed the required cable length for reliable communications. [Table 4-3](#) lists the cable length requirements.

Table 4-3 Cabling Requirements for Fiber-Optic SFP Modules

SFP Module	62.5/125 micron Multimode 850 nm Fiber	50/125 micron Multimode 850 nm Fiber	62.5/125 micron Multimode 1310 nm Fiber	50/125 micron Multimode 1310 nm Fiber	9/125 micron Single-mode 1310 nm Fiber
LX/LH	—	—	550 m at 500 Mhz-km	550 m at 400 Mhz-km	10 km
SX	275 m at 200 Mhz-km	550 m at 500 Mhz-km	—	—	—

Use only Cisco certified SFP modules on the adaptive security appliance. Each SFP module has an internal serial EEPROM that is encoded with security information. This encoding provides a way for Cisco to identify and validate that the SFP module meets the requirements for the adaptive security appliance.

**Note**

Only SFP modules certified by Cisco are supported on the adaptive security appliance.

**Caution**

Protect your SFP modules by inserting clean dust plugs into the SFPs after the cables are extracted from them. Be sure to clean the optic surfaces of the fiber cables before you plug them back into the optical bores of another SFP module. Avoid getting dust and other contaminants into the optical bores of your SFP modules. The optics do not work correctly when obstructed with dust.

**Warning**

Because invisible laser radiation may be emitted from the aperture of the port when no cable is connected, avoid exposure to laser radiation and do not stare into open apertures. Statement 70

Installing the SFP Module

To install the SFP module in the 4GE SSM, perform the following steps:

- Step 1** Line up the SFP module with the port and slide the SFP module into the port slot until it locks into position as shown in [Figure 4-20](#).

Figure 4-20 Installing an SFP Module

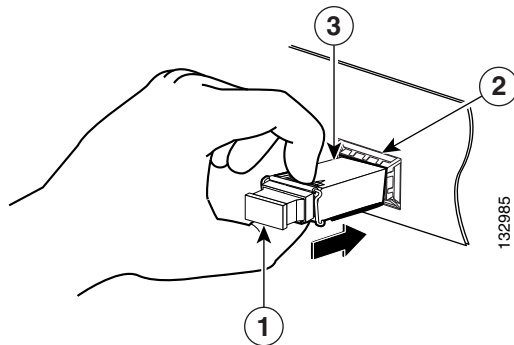

1	Optical port plug	2	SFP port slot
3	SFP module		



Caution

Do not remove the optical port plugs from the SFP until you are ready to connect cabling.

- Step 2** Remove the Optical port plug; then connect the network cable to the SFP module.
- Step 3** Connect the other end of the cable to your network.



Caution

The latching mechanism used on many SFPs locks them into place when cables are connected. Do not pull on the cabling in an attempt to remove the SFP.

Removing the SFP Module

The SFP modules have different types of latching devices used to detach the SFP module from a port. The following are the different types of modules:

- Mylar Tab Module
- Actuator/Button SFP Module
- Bale-Clasp SFP Module
- Plastic Collar Module

To remove the SFP module, perform the following steps:

Step 1 Disconnect all cables from the SFP.



Warning

Because invisible laser radiation may be emitted from the aperture of the port when no cable is connected, avoid exposure to laser radiation and do not stare into open apertures. Statement 70



Caution

The latching mechanism used on many SFPs locks the SFP into place when cables are connected. Do not pull on the cabling in an attempt to remove the SFP.

Step 2 Disconnect the SFP latch as shown in [Figure 4-21](#).



Note

SFP modules use various latch designs to secure the module in the SFP port. Latch designs are not linked to SFP model or technology type. For information on the SFP technology type and model, see the label on the side of the SFP.

Figure 4-21 Disconnecting SFP Latch Mechanisms

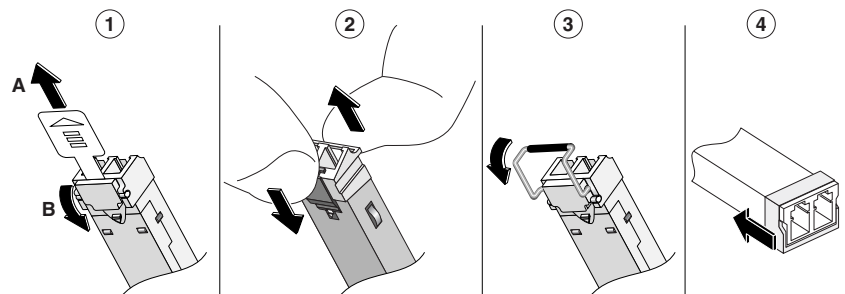

1	Mylar tab	2	Actuator/Button
3	Bale-clasp	4	Plastic collar

Step 3 Grasp the SFP on both sides and remove it from the port.

Installing and Replacing the Intelligent SSM

The Cisco ASA 5510, Cisco ASA 5520, Cisco ASA 5540 support the AIP SSM and the CSC SSM, also referred to as the intelligent SSM in this document. The AIP SSM runs advanced IPS software that provides security inspection. There are three types of AIP SSM: the AIP SSM 10, AIP SSM 20 and the AIP SSM 40. The AIP SSM 10 and the AIP SSM 20 look identical, but the AIP SSM 20 has a faster processor and more memory than the AIP SSM 10. The AIP SSM 40 has a faster processor and more memory than both the AIP SSM 10 and the AIP SSM 20. Only one module (the AIP SSM 10, AIP SSM 20, or the AIP SSM 40) can populate the slot at a time.

[Table 4-4](#) lists the memory specifications for the AIP SSM 10, AIP SSM 20, and the AIP SSM 40.

Table 4-4 AIP/CSC SSM Memory Specifications

SSM	CPU	DRAM
AIP SSM 10	2.0 GHz Celeron	1.0 GB
AIP SSM 20	2.4 GHz Pentium 4	2.0 GB
AIP SSM 40	2.0 GHz Xeon LV	4.0 GB

For more information on the AIP SSM 10/20/40, see the “[Managing the AIP SSM](#)” section in the *Cisco Security Appliance Command Line Configuration Guide*.

The CSC SSM runs Content Security and Control software. The CSC SSM provides protection against viruses, spyware, spam, and other unwanted traffic. There are two types of CSC SSM: the CSC SSM 10, and the CSC SSM 20. For more information on the CSC SSM 10/20, see the “[Managing the CSC SSM](#)” section in the *Cisco Security Appliance Command Line Configuration Guide*.

[Table 4-5](#) shows the AIP/CSC SSMs supported by each platform:

Table 4-5 SSM Support

Platform	SSM Models
Cisco ASA 5510	AIP SSM 10 CSC SSM 10 CSC SSM 20 4GE SSM
Cisco ASA 5520	AIP SSM 10 AIP SSM 20 AIP SSM 40 CSC SSM 10 CSC SSM 20 4GE SSM
Cisco ASA 5540	AIP SSM 10 AIP SSM 20 AIP SSM 40 4GE SSM

This section describes how to install and replace the AIP/CSC SSM in the adaptive security appliance, and includes the following topics:

- [Overview, page 4-21](#)
- [Installing and Replacing the AIP/CSC SSM, page 4-22](#)

Overview

Figure 4-22 lists the AIP/CSC SSM 10/20 LEDs.

Figure 4-22 AIP/CSC SSM 10/20 LEDs

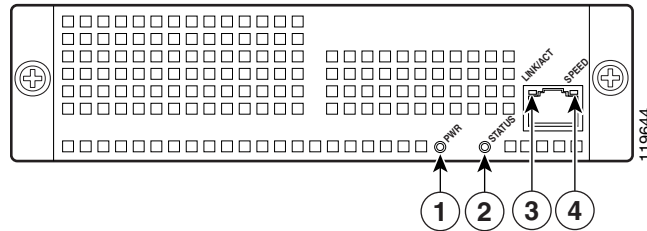

Table 4-6 describes the AIP/CSC SSM 10/20 LEDs.

Table 4-6 AIP/CSC SSM 10/20 LEDs

	LED	Color	State	Description
1	PWR	Green	On	The system has power.
2	STATUS	Green	Flashing	The system is booting.
			Solid	The system has passed power-up diagnostics.
3	LINK/ACT	Green	Solid	There is an Ethernet link.
			Flashing	There is Ethernet activity.
4	SPEED	Off	10 MB	Indicates a 10MB connection.
		Green	100 MB	Indicates a 100MB connection.
		Amber	1000 MB (GigE)	Indicates a 1000MB connection.

Figure 4-23 lists the AIP/CSC SSM 40 LEDs.

Figure 4-23 AIP/CSC SSM 40 LEDs

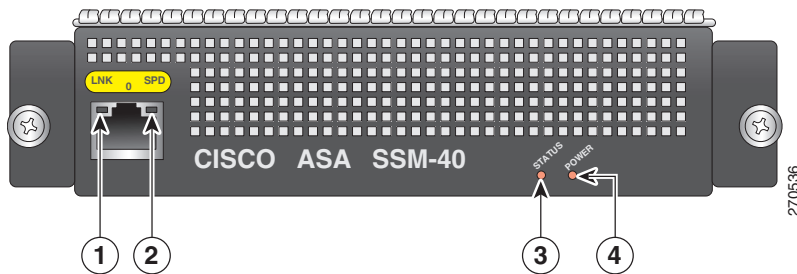

Table 4-6 describes the AIP/CSC SSM 10/20 LEDs.

Table 4-7 AIP/CSC SSM 40 LEDs

	LED	Color	State	Description
1	LNK	Green	Solid Flashing	There is an Ethernet link. There is Ethernet activity.
2	SPEED	Off Green Amber	10 MB 100 MB 1000 MB (GigE)	Indicates a 10MB connection. Indicates a 100MB connection. Indicates a 1000MB connection.
3	STATUS	Green	Solid Flashing	The system is booting. The system has passed power-up diagnostics.
4	POWER	Green	On	The system has power.

Installing and Replacing the AIP/CSC SSM

This section describes how to install and replace the AIP/CSC SSM in the adaptive security appliance. The section includes the following topics:

- [Installing the AIP/CSC SSM, page 4-22](#)
- [Replacing the AIP/CSC SSM, page 4-23](#)

Installing the AIP/CSC SSM

To install a new AIP/CSC SSM for the first time, perform the following steps:

-
- Step 1** Enter the `hw-mod mod 1 shut` command in privileged EXEC mode. Verify that the module is down by making sure that the LEDs are all off.
- Step 2** Locate the grounding strap from the accessory kit and fasten it to your wrist so that it contacts your bare skin. Attach the other end to the chassis.
- Step 3** Remove the two screws at the left rear end of the chassis, and remove the slot cover as shown in [Figure 4-24](#).

Figure 4-24 Removing the Screws from the Slot Cover

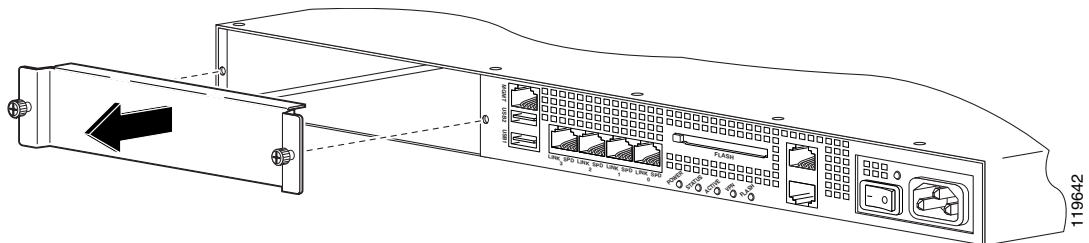

- Step 4** Insert the AIP/CSC SSM in to the slot opening as shown in [Figure 4-25](#).

Figure 4-25 Inserting the AIP/CSC SSM into the Slot

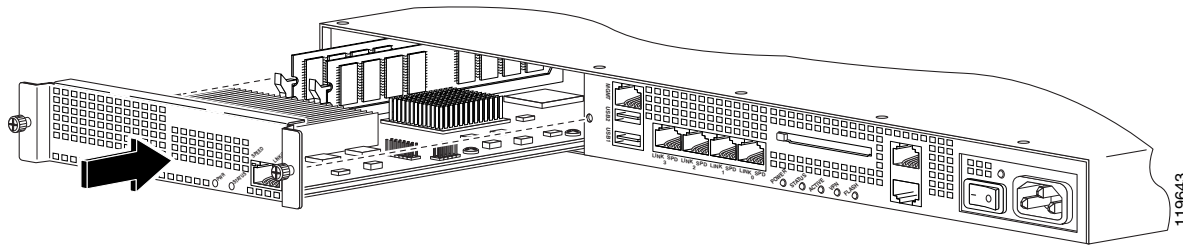

- Step 5** Attach the screws to secure the AIP/CSC SSM to the chassis.
- Step 6** Enter the **hw-mod mod 1 reset** command in privileged EXEC mode to reset the AIP/CSC SSM.
- Step 7** Check the LEDs. If the AIP/CSC SSM is installed properly, the POWER LED is solid green and the STATUS LED flashes green.

Replacing the AIP/CSC SSM

To replace an existing AIP/CSC SSM, perform the following steps:

- Step 1** Enter the **hw-mod mod 1 shut** command in privileged EXEC mode. Verify that the module is down by making sure that the LEDs are all off.
- Step 2** Locate the grounding strap from the accessory kit and fasten it to your wrist, so that it contacts your bare skin. Attach the other end to the chassis.
- Step 3** Remove the two screws at the left rear end of the chassis.
- Step 4** Remove the AIP/CSC SSM. Place it in a static bag and set it aside.
- Step 5** Replace the existing card by inserting the new AIP/CSC SSM through the slot opening.
- Step 6** Attach the screws to secure the AIP/CSC SSM to the chassis.
- Step 7** Enter the **hw-mod mod 1 reset** command in privileged EXEC mode to reset the AIP/CSC SSM.
- Step 8** Check the LEDs. If the AIP/CSC SSM is installed properly, the POWER LED is solid green and the STATUS LED flashes green.

Upgrading Memory in the Adaptive Security Appliance

This section describes how to upgrade the memory in the adaptive security appliance. The section includes the following topics:

- [Overview, page 4-24](#)
- [Removing and Installing the DIMM, page 4-25](#)

Overview

Cisco ASA 5510

The memory upgrade kit, ASA5510-MEM-512=, allows you to upgrade the memory in your Cisco ASA 5510.

To determine how much memory your adaptive security appliance has, use the **show version** command, the example below is for the Cisco ASA 5510 chassis:

```
hostname# show version

Cisco Adaptive Security Appliance Software Version 8.0(4)
Device Manager Version 6.1(5)

Compiled on Thu 07-Aug-08 20:53 by builders
System image file is "disk0:/asa804-k8.bin"
Config file at boot was "startup-config"

ciscoasa up 2 days 10 hours
failover cluster up 2 days 11 hours

Hardware: ASA5510, 256 MB RAM, CPU Pentium 4 Celeron 1600 MHz
BIOS Flash AT49LW080 @ 0xffe00000, 1024KB
```

Table 4-8 lists the memory for the Cisco ASA 5510.

Table 4-8 Memory Upgrade

Model	Current Memory	Upgrade to
Cisco ASA 5510	256 MB	512 MB

Cisco ASA 5520/40

The memory upgrade kits, ASA5520-MEM-2GB=, and the ASA5540-MEM-2GB= allows you to upgrade the Cisco ASA 5520 and your Cisco ASA 5540 respectively. To see how much memory your adaptive security appliance has, use the **show version** command.

To determine how much memory your adaptive security appliance has, use the **show version** command, the example below is for the Cisco ASA 5520 chassis:

```
hostname# show version

Cisco Adaptive Security Appliance Software Version 8.0(0)
Device Manager Version 6.0(0)

Compiled on Mon 16-April-07 03:29 by root
System image file is "disk0:/cdisk.bin"
Config file at boot was "disk0:/main_backup.cfg"

hostname up 2 days 10 hours
failover cluster up 2 days 11 hours

Hardware: ASA5520, 512 MB RAM, CPU Pentium 4 Celeron 2000 MHz
BIOS Flash M50FW016 @ 0xffe00000, 2048KB
```

Table 4-8 lists the memory for the Cisco ASA 5520 and Cisco ASA 5540.

Table 9 Memory Upgrade

Model	Current Memory	Upgrade to
Cisco ASA 5520	512 MB	2 GB
Cisco ASA 5540	1 GB	2 GB

Removing and Installing the DIMM

This section describes how to remove and install the memory module on the adaptive security appliance. This section includes the following topics:

- [Removing the DIMM, page 4-25](#)
- [Installing the DIMM, page 4-28](#)

Removing the DIMM

To remove the memory module, perform the following steps:

-
- Step 1** Power off the adaptive security appliance.
 - Step 2** Remove the power cord and other cables from the adaptive security appliance.
 - Step 3** Remove the adaptive security appliance from the rack if it is rack-mounted.
 - Step 4** Place the adaptive security appliance in an ESD-controlled environment. See the “[Working in an ESD Environment](#)” section on page 4-3 for more information.
 - Step 5** Remove the adaptive security appliance cover. See the “[Removing and Replacing the Chassis Cover](#)” section on page 4-1 for the procedure.
 - Step 6** Determine the location of the memory sockets. See [Figure 4-26](#) for the Cisco ASA 5510 and [Figure 4-27](#) for the Cisco ASA 5520 or Cisco ASA 5540.



Note Some Cisco ASA 5510 have only a single memory socket, see [Figure 4-26](#). while others have four memory sockets. In both cases, remove the existing DIMM, and replace it with the new one. For memory upgrade in the Cisco ASA 5510 with four memory sockets, use slot 1 - P13 and note that only one slot must be populated at all times.

Figure 4-26 System Memory Location in the Cisco ASA 5510

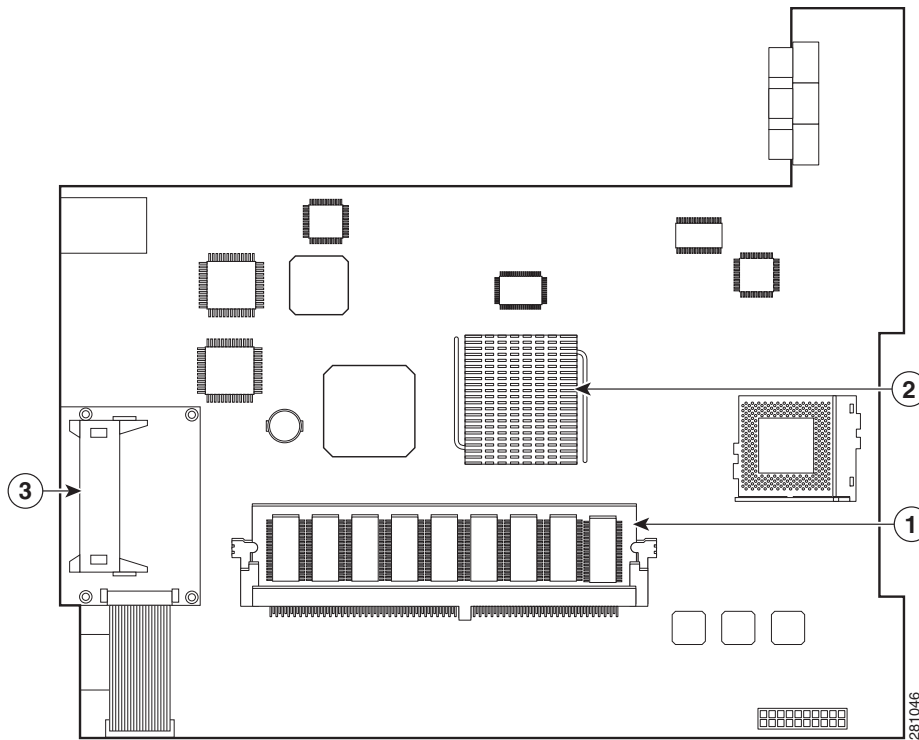

1	DIMM
2	Memory Controller Hub (MCH)
3	CompactFlash socket

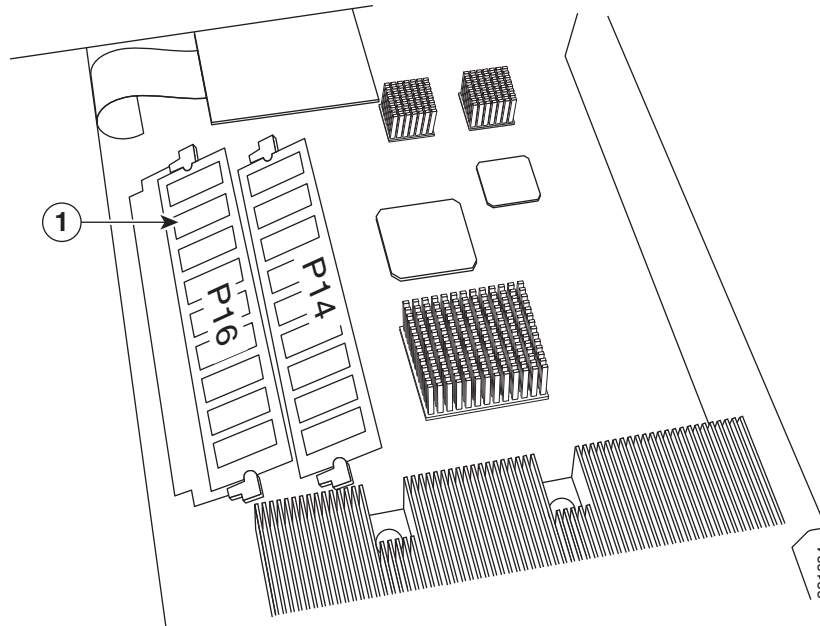
Figure 4-27 System Memory Location in the Cisco ASA 5520 and the Cisco ASA 5540

1	DIMM
----------	------



Note All ASA-5520s and ASA-5540s manufactured before August 2011 have 4 DIMM sockets. ASA-5520s and ASA-5540s manufactured after this date have 2 DIMM sockets.

- Step 7** Locate the wrist grounding strap and connect one end to the adaptive security appliance, and securely attach the other end to your wrist so it contacts your bare skin. See, [“Working in an ESD Environment” section on page 4-3](#) for more information.



Note Handle the edges of the DIMM only; avoid touching the memory modules, pins, or traces (the metal fingers along the connector edge of the DIMM), along the connector edge.

To prevent ESD damage, handle DIMMs as shown in [Figure 4-28](#).

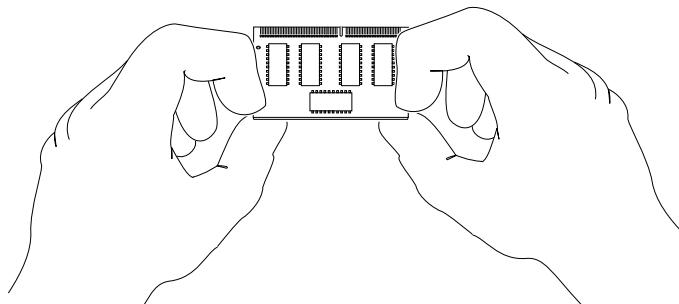
Figure 4-28 Handling a DIMM

33115

- Step 8** Pull the latches away from the DIMM at both ends and release the DIMM from the socket. See [Figure 4-29](#).
- Step 9** When both ends of the DIMM are released from the socket, grasp the ends of the DIMM with your thumb and forefinger and pull the DIMM completely out of the socket.
- Step 10** Place the DIMM in an antistatic container to protect it from ESD damage.

Figure 4-29 Releasing the DIMM Latches

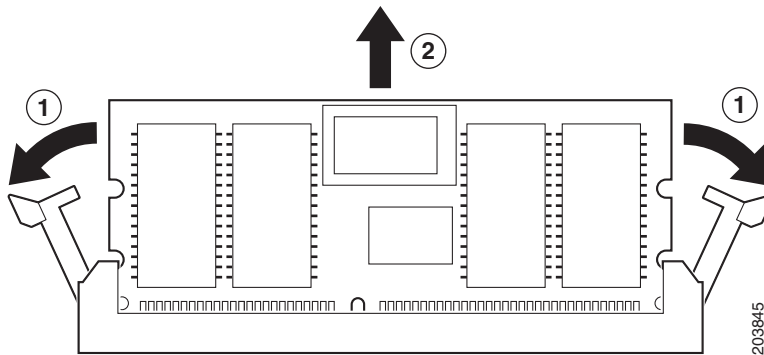

Installing the DIMM

To install the memory module, perform the following steps:

- Step 1** Make sure that both latches on the DIMM connector are open.
- Step 2** Remove a new DIMM from the antistatic container.
- The DIMM is designed in such a way that the connector will fit only one way.
- Step 3** Hold the DIMM component side up, with the connector edge away from you. Line up the notch in the connector traces with the notch in the socket on the board.
- Step 4** Carefully insert the connector edge into the socket and firmly press the DIMM into the socket until both latches rotate to the close position against the DIMM.



Note For memory upgrade in the Cisco ASA 5510 with four memory sockets, use slot 1 - P13 and note that only one slot must be populated at all times.

Figure 4-30 Inserting the DIMM

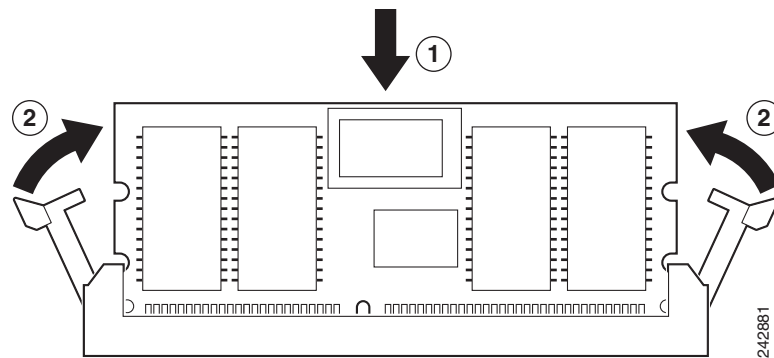
**Caution**

When inserting DIMMs, use pressure, but not excessive pressure as this can cause damage to the socket.

- Step 5** When you finish installing the DIMM, replace the adaptive security appliance cover. See the [“Removing and Replacing the Chassis Cover”](#) section on page 4-1 for the procedure.
- Step 6** Reinstall the network interface cables.

Verifying the Memory Upgrade

Cisco ASA 5510

You can verify that the memory upgrade has been completed successfully by entering the **show version** command, the example below is for the Cisco ASA 5510 chassis:

```
hostname# show version

Cisco Adaptive Security Appliance Software Version 8.0(4)
Device Manager Version 6.1(5)

Compiled on Thu 07-Aug-08 20:53 by builders
System image file is "disk0:/asa804-k8.bin"
Config file at boot was "startup-config"

ciscoasa up 2 days 10 hours
failover cluster up 2 days 11 hours

Hardware: ASA5510, 1 GB RAM, CPU Pentium 4 Celeron 1600 MHz
BIOS Flash AT49LW080 @ 0xffe00000, 1024KB
```

Cisco ASA 5520/40

You can verify that the memory upgrade has been completed successfully by entering the **show version** command, the example below is for the Cisco ASA 5520 chassis:

```
hostname# show version

Cisco Adaptive Security Appliance Software Version 8.0(0)
Device Manager Version 6.0(0)

Compiled on Mon 16-April-07 03:29 by root
```

```
System image file is "disk0:/cdisk.bin"  
Config file at boot was "disk0:/main_backup.cfg"  
hostname up 2 days 10 hours  
failover cluster up 2 days 11 hours  
Hardware: ASA5520, 2 GB RAM, CPU Pentium 4 Celeron 2000 MHz  
BIOS Flash M50FW016 @ 0xffe00000, 2048KB
```
