



## Configuring VTP

---

This chapter describes how to configure the VLAN Trunking Protocol (VTP) on the Cisco 7600 series routers.



**Note**

For complete syntax and usage information for the commands used in this chapter, refer to the *Cisco 7600 Series Router Cisco IOS Command Reference* at this URL:

[http://www.cisco.com/en/US/docs/ios/mcl/122sxmcl/12\\_2sx\\_mcl\\_book.html](http://www.cisco.com/en/US/docs/ios/mcl/122sxmcl/12_2sx_mcl_book.html)

---

This chapter consists of these sections:

- [Understanding How VTP Works, page 13-1](#)
- [VTP Default Configuration, page 13-5](#)
- [VTP Configuration Guidelines and Restrictions, page 13-5](#)
- [Configuring VTP, page 13-6](#)

## Understanding How VTP Works

VTP is a Layer 2 messaging protocol that maintains VLAN configuration consistency by managing the addition, deletion, and renaming of VLANs within a VTP domain. A VTP domain (also called a VLAN management domain) is made up of one or more network devices that share the same VTP domain name and that are interconnected with trunks. VTP minimizes misconfigurations and configuration inconsistencies that can result in a number of problems, such as duplicate VLAN names, incorrect VLAN-type specifications, and security violations. Before you create VLANs, you must decide whether to use VTP in your network. With VTP, you can make configuration changes centrally on one or more network devices and have those changes automatically communicated to all the other network devices in the network.



**Note**

For complete information on configuring VLANs, see [Chapter 14, “Configuring VLANs.”](#)

---

These sections describe how VTP works:

- [Understanding the VTP Domain, page 13-2](#)
- [Understanding VTP Modes, page 13-2](#)
- [Understanding VTP Advertisements, page 13-3](#)

- [Understanding VTP Version 2, page 13-3](#)
- [Understanding VTP Pruning, page 13-3](#)

## Understanding the VTP Domain

A VTP domain (also called a VLAN management domain) is made up of one or more interconnected network devices that share the same VTP domain name. A network device can be configured to be in one and only one VTP domain. You make global VLAN configuration changes for the domain using either the command-line interface (CLI) or Simple Network Management Protocol (SNMP).

By default, the Cisco 7600 series router is in VTP server mode and is in the no-management domain state until the router receives an advertisement for a domain over a trunk link or you configure a management domain.

If the router receives a VTP advertisement over a trunk link, it inherits the management domain name and the VTP configuration revision number. The router ignores advertisements with a different management domain name or an earlier configuration revision number.

If you configure the router as VTP transparent, you can create and modify VLANs but the changes affect only the individual router.

When you make a change to the VLAN configuration on a VTP server, the change is propagated to all network devices in the VTP domain. VTP advertisements are transmitted out all trunk connections.

VTP maps VLANs dynamically across multiple LAN types with unique names and internal index associations. Mapping eliminates excessive device administration required from network administrators.

## Understanding VTP Modes

You can configure a Cisco 7600 series router to operate in any one of these VTP modes:

- **Server**—In VTP server mode, you can create, modify, and delete VLANs and specify other configuration parameters (such as VTP version and VTP pruning) for the entire VTP domain. VTP servers advertise their VLAN configuration to other network devices in the same VTP domain and synchronize their VLAN configuration with other network devices based on advertisements received over trunk links. VTP server is the default mode.
- **Client**—VTP clients behave the same way as VTP servers, but you cannot create, change, or delete VLANs on a VTP client.
- **Transparent**—VTP transparent network devices do not participate in VTP. A VTP transparent network device does not advertise its VLAN configuration and does not synchronize its VLAN configuration based on received advertisements. However, in VTP version 2, transparent network devices do forward VTP advertisements that they receive out their trunking LAN ports.

**Note**

---

Cisco 7600 series routers automatically change from VTP server mode to VTP client mode if the router detects a failure while writing configuration to NVRAM. If this happens, the router cannot be returned to VTP server mode until the NVRAM is functioning.

---

## Understanding VTP Advertisements

Each network device in the VTP domain sends periodic advertisements out each trunking LAN port to a reserved multicast address. VTP advertisements are received by neighboring network devices, which update their VTP and VLAN configurations as necessary.

The following global configuration information is distributed in VTP advertisements:

- VLAN IDs (ISL and 802.1Q)
- Emulated LAN names (for ATM LANE)
- 802.10 SAID values (FDDI)
- VTP domain name
- VTP configuration revision number
- VLAN configuration, including maximum transmission unit (MTU) size for each VLAN
- Frame format

## Understanding VTP Version 2

If you use VTP in your network, you must decide whether to use VTP version 1 or version 2.

**Note**

---

If you are using VTP in a Token Ring environment, you must use version 2.

---

VTP version 2 supports the following features not supported in version 1:

- Token Ring support—VTP version 2 supports Token Ring LAN switching and VLANs (Token Ring Bridge Relay Function [TrBRF] and Token Ring Concentrator Relay Function [TrCRF]). For more information about Token Ring VLANs, see the [“Understanding How VLANs Work”](#) section on page 14-1.
- Unrecognized Type-Length-Value (TLV) Support—A VTP server or client propagates configuration changes to its other trunks, even for TLVs it is not able to parse. The unrecognized TLV is saved in NVRAM.
- Version-Dependent Transparent Mode—In VTP version 1, a VTP transparent network device inspects VTP messages for the domain name and version, and forwards a message only if the version and domain name match. Because only one domain is supported in the supervisor engine software, VTP version 2 forwards VTP messages in transparent mode without checking the version.
- Consistency Checks—In VTP version 2, VLAN consistency checks (such as VLAN names and values) are performed only when you enter new information through the CLI or SNMP. Consistency checks are not performed when new information is obtained from a VTP message, or when information is read from NVRAM. If the digest on a received VTP message is correct, its information is accepted without consistency checks.

## Understanding VTP Pruning

VTP pruning enhances network bandwidth use by reducing unnecessary flooded traffic, such as broadcast, multicast, unknown, and flooded unicast packets. VTP pruning increases available bandwidth by restricting flooded traffic to those trunk links that the traffic must use to access the appropriate network devices. By default, VTP pruning is disabled.

For VTP pruning to be effective, all devices in the management domain must support VTP pruning. On devices that do not support VTP pruning, you must manually configure the VLANs allowed on trunks.

Figure 13-1 shows a switched network without VTP pruning enabled. Interface 1 on network Switch 1 and port 2 on Switch 4 are assigned to the Red VLAN. A broadcast is sent from the host connected to Switch 1. Switch 1 floods the broadcast, and every network device in the network receives it, even though Switches 3, 5, and 6 have no ports in the Red VLAN.

You enable pruning globally on the Cisco 7600 series router (see the “Enabling VTP Pruning” section on page 13-7). You configure pruning on Layer 2 trunking LAN ports (see the “Configuring a Layer 2 Switching Port as a Trunk” section on page 10-7).

**Figure 13-1 Flooding Traffic without VTP Pruning**

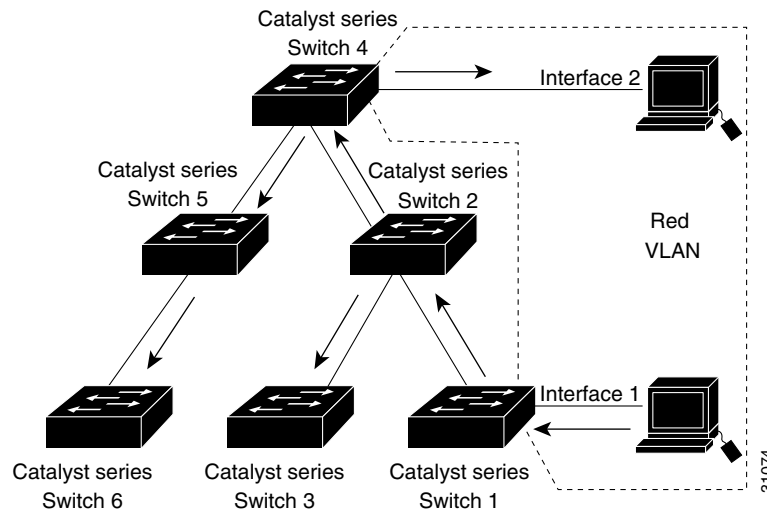
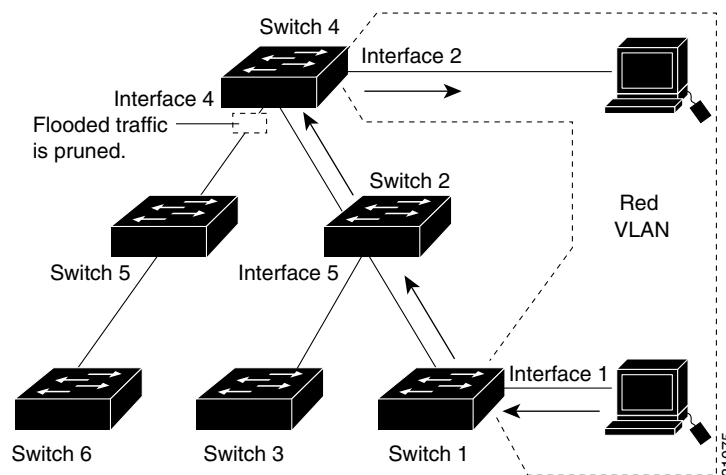

Figure 13-2 shows the same switched network with VTP pruning enabled. The broadcast traffic from Switch 1 is not forwarded to Switches 3, 5, and 6 because traffic for the Red VLAN has been pruned on the links indicated (port 5 on Switch 2 and port 4 on Switch 4).

**Figure 13-2 Flooding Traffic with VTP Pruning**



Enabling VTP pruning on a VTP server enables pruning for the entire management domain. VTP pruning takes effect several seconds after you enable it. By default, VLANs 2 through 1000 are pruning eligible. VTP pruning does not prune traffic from pruning-ineligible VLANs. VLAN 1 is always pruning ineligible; traffic from VLAN 1 cannot be pruned.

To configure VTP pruning on a trunking LAN port, use the **switchport trunk pruning vlan** command (see the “Configuring a Layer 2 Switching Port as a Trunk” section on page 10-7). VTP pruning operates when a LAN port is trunking. You can set VLAN pruning eligibility when VTP pruning is enabled or disabled for the VTP domain, when any given VLAN exists or not, and when the LAN port is currently trunking or not.

## VTP Default Configuration

Table 13-1 shows the default VTP configuration.

**Table 13-1 VTP Default Configuration**

Feature	Default Value
VTP domain name	Null
VTP mode	Server
VTP version 2 enable state	Version 2 is disabled
VTP password	None
VTP pruning	Disabled

## VTP Configuration Guidelines and Restrictions

When implementing VTP in your network, follow these guidelines and restrictions:

- Supervisor engine redundancy does not support nondefault VLAN data file names or locations. Do not enter the **vtp file file\_name** command on a router that has a redundant supervisor engine.
- Before installing a redundant supervisor engine, enter the **no vtp file** command to return to the default configuration.
- All network devices in a VTP domain must run the same VTP version.
- You must configure a password on each network device in the management domain when in secure mode.



### Caution

If you configure a VTP password, the management domain will not function properly if you do not assign a management domain password to each network device in the domain.

- A VTP version 2-capable network device can operate in the same VTP domain as a network device running VTP version 1 provided VTP version 2 is disabled on the VTP version 2-capable network device (VTP version 2 is disabled by default).
- Do not enable VTP version 2 on a network device unless all of the network devices in the same VTP domain are version 2-capable. When you enable VTP version 2 on a network device, all of the version 2-capable network devices in the domain enable VTP version 2.
- In a Token Ring environment, you must enable VTP version 2 for Token Ring VLAN switching to function properly.

- When you enable or disable VTP pruning on a VTP server, VTP pruning for the entire management domain is enabled or disabled.
- The pruning-eligibility configuration applies globally to all trunks on the router. You cannot configure pruning-eligibility separately for each trunk.
- When you configure VLANs as pruning eligible or pruning ineligible, pruning eligibility for those VLANs is affected on that router only, not on all network devices in the VTP domain.
- VTPv1 and VTPv2 do not propagate configuration information for extended-range VLANs (VLAN numbers 1006 to 4094). You must configure extended-range VLANs manually on each network device.
- If there is insufficient DRAM available for use by VTP, the VTP mode changes to transparent.
- Network devices in VTP transparent mode do not send VTP Join messages. On Cisco 7600 series routers with trunk connections to network devices in VTP transparent mode, configure the VLANs that are used by the transparent-mode network devices or that need to be carried across trunks as pruning ineligible. For information about configuring prune eligibility, see the [“Configuring the List of Prune-Eligible VLANs” section on page 10-11](#).

## Configuring VTP

These sections describe how to configure VTP:

- [Configuring VTP Global Parameters, page 13-6](#)
- [Configuring the VTP Mode, page 13-8](#)
- [Displaying VTP Statistics, page 13-10](#)

## Configuring VTP Global Parameters

These sections describe configuring the VTP global parameters:

- [Configuring a VTP Password, page 13-6](#)
- [Enabling VTP Pruning, page 13-7](#)
- [Enabling VTP Version 2, page 13-7](#)



### Note

You can enter the VTP global parameters in either global configuration mode or in EXEC mode.

## Configuring a VTP Password

To configure the VTP global parameters, perform this task:

Command	Purpose
Router(config)# <b>vtp password</b> <i>password_string</i>	Sets a password, which can be from 8 to 64 characters long, for the VTP domain.
Router(config)# <b>no vtp password</b>	Clears the password.

This example shows one way to configure a VTP password in global configuration mode:

```
Router# configure terminal
Router(config)# vtp password WATER
Setting device VLAN database password to WATER.
Router#
```

This example shows how to configure a VTP password in EXEC mode:

```
Router# vtp password WATER
Setting device VLAN database password to WATER.
Router#
```



**Note**

The password is not stored in the running-config file.

## Enabling VTP Pruning

To enable VTP pruning in the management domain, perform this task:

	Command	Purpose
Step 1	Router(config)# <b>vtp pruning</b>	Enables VTP pruning in the management domain.
	Router(config)# <b>no vtp pruning</b>	Disables VTP pruning in the management domain.
Step 2	Router# <b>show vtp status</b>	Verifies the configuration.

This example shows one way to enable VTP pruning in the management domain:

```
Router# configure terminal
Router(config)# vtp pruning
Pruning switched ON
```

This example shows how to enable VTP pruning in the management domain with any release:

```
Router# vtp pruning
Pruning switched ON
```

This example shows how to verify the configuration:

```
Router# show vtp status | include Pruning
VTP Pruning Mode: Enabled
Router#
```

For information about configuring prune eligibility, see the [“Configuring the List of Prune-Eligible VLANs”](#) section on page 10-11.

## Enabling VTP Version 2

VTP version 2 is disabled by default on VTP version 2-capable network devices. When you enable VTP version 2 on a network device, every VTP version 2-capable network device in the VTP domain enables version 2.



**Caution**

VTP version 1 and VTP version 2 are not interoperable on network devices in the same VTP domain. Every network device in the VTP domain must use the same VTP version. Do not enable VTP version 2 unless every network device in the VTP domain supports version 2.

**Note**

In a Token Ring environment, you must enable VTP version 2 for Token Ring VLAN switching to function properly on devices that support Token Ring interfaces.

To enable VTP version 2, perform this task:

	Command	Purpose
<b>Step 1</b>	Router(config)# <b>vtp version</b> {1   2}	Enables VTP version 2.
	Router(config)# <b>no vtp version</b>	Reverts to the default (VTP version 1).
<b>Step 2</b>	Router# <b>show vtp status</b>	Verifies the configuration.

This example shows one way to enable VTP version 2:

```
Router# configure terminal
Router(config)# vtp version 2
V2 mode enabled.
Router(config)#
```

This example shows how to enable VTP version 2 with any release:

```
Router# vtp version 2
V2 mode enabled.
Router#
```

This example shows how to verify the configuration:

```
Router# show vtp status | include v2
VTP V2 Mode: Enabled
Router#
```

## Configuring the VTP Mode

To configure the VTP mode, perform this task:

	Command	Purpose
<b>Step 1</b>	Router(config)# <b>vtp mode</b> {client   server   transparent}	Configures the VTP mode.
	Router(config)# <b>no vtp mode</b>	Reverts to the default VTP mode (server).
<b>Step 2</b>	Router(config)# <b>vtp domain</b> <i>domain_name</i>	(Optional for server mode) Defines the VTP domain name, which can be up to 32 characters long. VTP server mode requires a domain name. If the router has a trunk connection to a VTP domain, the router learns the domain name from the VTP server in the domain. <b>Note</b> You cannot clear the domain name.
<b>Step 3</b>	Router(config)# <b>end</b>	Exits VLAN configuration mode.
<b>Step 4</b>	Router# <b>show vtp status</b>	Verifies the configuration.

**Note**

In VTP transparent mode, the VLAN configuration is stored in the startup configuration file.

This example shows how to configure the router as a VTP server:

```
Router# configuration terminal
Router(config)# vtp mode server
Setting device to VTP SERVER mode.
Router(config)# vtp domain Lab_Network
Setting VTP domain name to Lab_Network
Router(config)# end
Router#
```

This example shows how to verify the configuration:

```
Router# show vtp status
VTP Version                : 2
Configuration Revision     : 247
Maximum VLANs supported locally : 1005
Number of existing VLANs   : 33
VTP Operating Mode        : Server
VTP Domain Name           : Lab_Network
VTP Pruning Mode          : Enabled
VTP V2 Mode               : Disabled
VTP Traps Generation      : Disabled
MD5 digest                 : 0x45 0x52 0xB6 0xFD 0x63 0xC8 0x49 0x80
Configuration last modified by 0.0.0.0 at 8-12-99 15:04:49
Local updater ID is 172.20.52.34 on interface Gi1/1 (first interface found)
Router#
```

This example shows how to configure the router as a VTP client:

```
Router# configuration terminal
Router(config)# vtp mode client
Setting device to VTP CLIENT mode.
Router(config)# exit
Router#
```

This example shows how to verify the configuration:

```
Router# show vtp status
VTP Version                : 2
Configuration Revision     : 247
Maximum VLANs supported locally : 1005
Number of existing VLANs   : 33
VTP Operating Mode        : Client
VTP Domain Name           : Lab_Network
VTP Pruning Mode          : Enabled
VTP V2 Mode               : Disabled
VTP Traps Generation      : Disabled
MD5 digest                 : 0x45 0x52 0xB6 0xFD 0x63 0xC8 0x49 0x80
Configuration last modified by 0.0.0.0 at 8-12-99 15:04:49
Router#
```

This example shows how to disable VTP on the router:

```
Router# configuration terminal
Router(config)# vtp transparent
Setting device to VTP TRANSPARENT mode.
Router(config)# end
Router#
```

This example shows how to verify the configuration:

```
Router# show vtp status
VTP Version                : 2
Configuration Revision     : 247
Maximum VLANs supported locally : 1005
Number of existing VLANs   : 33
VTP Operating Mode         : Transparent
VTP Domain Name            : Lab_Network
VTP Pruning Mode           : Enabled
VTP V2 Mode                 : Disabled
VTP Traps Generation       : Disabled
MD5 digest                  : 0x45 0x52 0xB6 0xFD 0x63 0xC8 0x49 0x80
Configuration last modified by 0.0.0.0 at 8-12-99 15:04:49
Router#
```

## Displaying VTP Statistics

To display VTP statistics, including VTP advertisements sent and received and VTP errors, perform this task:

Command	Purpose
Router# <b>show vtp counters</b>	Displays VTP statistics.

This example shows how to display VTP statistics:

```
Router# show vtp counters
VTP statistics:
Summary advertisements received : 7
Subset advertisements received  : 5
Request advertisements received  : 0
Summary advertisements transmitted : 997
Subset advertisements transmitted : 13
Request advertisements transmitted : 3
Number of config revision errors  : 0
Number of config digest errors    : 0
Number of V1 summary errors       : 0

VTP pruning statistics:

Trunk          Join Transmitted Join Received  Summary advts received from
-----          -----          -----          -----
Pa5/8          43071          42766          5
```