



Configuring VLANs

This chapter describes how to configure VLANs on the Cisco 7600 series routers.



Note

For complete syntax and usage information for the commands used in this chapter, refer to the *Cisco 7600 Series Router Cisco IOS Command Reference* at this URL:

http://www.cisco.com/en/US/docs/ios/mcl/122sxmcl/12_2sx_mcl_book.html

This chapter consists of these sections:

- [Understanding How VLANs Work, page 14-1](#)
- [VLAN Default Configuration, page 14-6](#)
- [VLAN Configuration Guidelines and Restrictions, page 14-8](#)
- [Configuring VLANs, page 14-9](#)

Understanding How VLANs Work

The following sections describe how VLANs work:

- [VLAN Overview, page 14-1](#)
- [VLAN Ranges, page 14-2](#)
- [Configurable VLAN Parameters, page 14-3](#)
- [Understanding Token Ring VLANs, page 14-3](#)

VLAN Overview

A VLAN is a group of end stations with a common set of requirements, independent of physical location. VLANs have the same attributes as a physical LAN but allow you to group end stations even if they are not located physically on the same LAN segment.

VLANs are usually associated with IP subnetworks. For example, all the end stations in a particular IP subnet belong to the same VLAN. Traffic between VLANs must be routed. LAN port VLAN membership is assigned manually on a port-by-port basis.

VLAN Ranges

Note

You must enable the extended system ID to use 4096 VLANs (see the [“Understanding the Bridge ID” section on page 20-2](#)).

Cisco 7600 series routers support 4096 VLANs in accordance with the IEEE 802.1Q standard. These VLANs are organized into several ranges; you use each range slightly differently. Some of these VLANs are propagated to other switches in the network when you use the VLAN Trunking Protocol (VTP). The extended-range VLANs are not propagated, so you must configure extended-range VLANs manually on each network device.

[Table 14-1](#) describes the VLAN ranges.

Table 14-1 VLAN Ranges

VLANs	Range	Usage	Propagated by VTP
0, 4095	Reserved	For system use only. You cannot see or use these VLANs.	—
1	Normal	Cisco default. You can use this VLAN but you cannot delete it.	Yes
2–1001	Normal	For Ethernet VLANs; you can create, use, and delete these VLANs.	Yes
1002–1005	Normal	Cisco defaults for FDDI and Token Ring. You cannot delete VLANs 1002–1005.	Yes
1006–4094	Extended	For Ethernet VLANs only.	No

The following information applies to VLAN ranges:

- Layer 3 LAN ports, WAN interfaces and subinterfaces, and some software features use internal VLANs in the extended range. You cannot use an extended range VLAN that has been allocated for internal use.
- To display the VLANs used internally, enter the **show vlan internal usage** command. With earlier releases, enter the **show vlan internal usage** and **show cwan vlans** commands.
- You can configure ascending internal VLAN allocation (from 1006 and up) or descending internal VLAN allocation (from 4094 and down).
- You must enable the extended system ID to use extended range VLANs (see the [“Understanding the Bridge ID” section on page 20-2](#)).

Configurable VLAN Parameters

**Note**

- Ethernet VLAN 1 uses only default values.
- Except for the VLAN name, Ethernet VLANs 1006 through 4094 use only default values.
- You can configure the VLAN name for Ethernet VLANs 1006 through 4094.

You can configure the following parameters for VLANs 2 through 1001:

- VLAN name
- VLAN type (Ethernet, FDDI, FDDI network entity title [NET], TrBRF, or TrCRF)
- VLAN state (active or suspended)
- Security Association Identifier (SAID)
- Bridge identification number for TrBRF VLANs
- Ring number for FDDI and TrCRF VLANs
- Parent VLAN number for TrCRF VLANs
- Spanning Tree Protocol (STP) type for TrCRF VLANs

Understanding Token Ring VLANs

The following section describes the two Token Ring VLAN types supported on network devices running VTP version 2:

- [Token Ring TrBRF VLANs, page 14-3](#)
- [Token Ring TrCRF VLANs, page 14-4](#)

**Note**

Cisco 7600 series routers do not support Inter-Switch Link (ISL)-encapsulated Token Ring frames. When a Cisco 7600 series router is configured as a VTP server, you can configure Token Ring VLANs from the router.

Token Ring TrBRF VLANs

Token Ring Bridge Relay Function (TrBRF) VLANs interconnect multiple Token Ring Concentrator Relay Function (TrCRF) VLANs in a switched Token Ring network (see [Figure 14-1](#)). The TrBRF can be extended across a network devices interconnected via trunk links. The connection between the TrCRF and the TrBRF is referred to as a *logical port*.

Figure 14-1 Interconnected Token Ring TrBRF and TrCRF VLANs

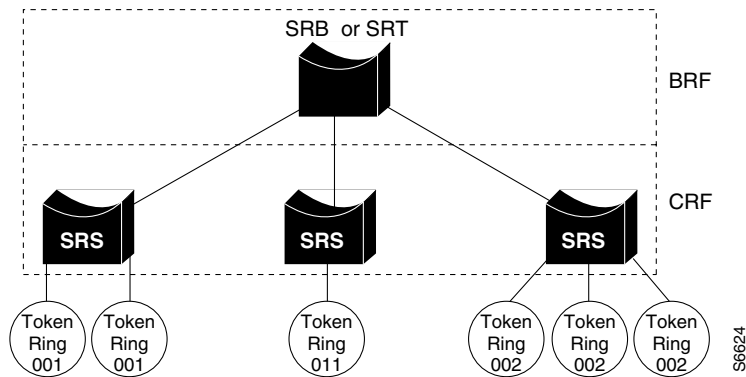

For source routing, the Cisco 7600 series router appears as a single bridge between the logical rings. The TrBRF can function as a source-route bridge (SRB) or a source-route transparent (SRT) bridge running either the IBM or IEEE STP. If an SRB is used, you can define duplicate MAC addresses on different logical rings.

The Token Ring software runs an instance of STP for each TrBRF VLAN and each TrCRF VLAN. For TrCRF VLANs, STP removes loops in the logical ring. For TrBRF VLANs, STP interacts with external bridges to remove loops from the bridge topology, similar to STP operation on Ethernet VLANs.

**Caution**

Certain parent TrBRF STP and TrCRF bridge mode configurations can place the logical ports (the connection between the TrBRF and the TrCRF) of the TrBRF in a blocked state. For more information, see the “[VLAN Configuration Guidelines and Restrictions](#)” section on page 14-8.

To accommodate IBM System Network Architecture (SNA) traffic, you can use a combination of SRT and SRB modes. In a mixed mode, the TrBRF determines that some ports (logical ports connected to TrCRFs) operate in SRB mode while other ports operate in SRT mode.

Token Ring TrCRF VLANs

Token Ring Concentrator Relay Function (TrCRF) VLANs define port groups with the same logical ring number. You can configure two types of TrCRFs in your network: undistributed and backup.

TrCRFs typically are undistributed, which means each TrCRF is limited to the ports on a single network device. Multiple undistributed TrCRFs on the same or separate network devices can be associated with a single parent TrBRF (see [Figure 14-2](#)). The parent TrBRF acts as a multiport bridge, forwarding traffic between the undistributed TrCRFs.

**Note**

To pass data between rings located on separate network devices, you can associate the rings to the same TrBRF and configure the TrBRF for an SRB.

Figure 14-2 Undistributed TrCRFs

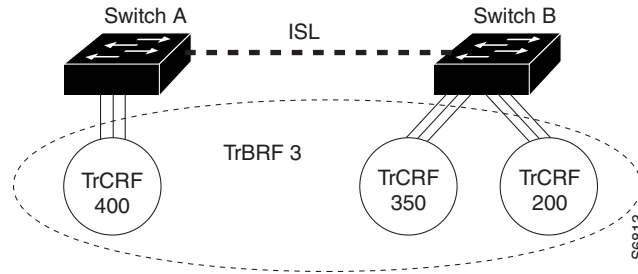

By default, Token Ring ports are associated with the default TrCRF (VLAN 1003, trcrf-default), which has the default TrBRF (VLAN 1005, trbrf-default) as its parent. In this configuration, a distributed TrCRF is possible (see Figure 14-3), and traffic is passed between the default TrCRFs located on separate network devices if the network devices are connected through an ISL trunk.

Figure 14-3 Distributed TrCRF

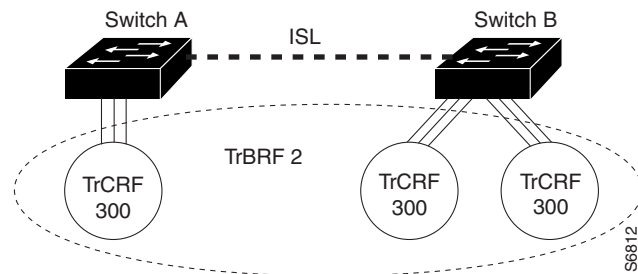

Within a TrCRF, source-route switching forwards frames based on either MAC addresses or route descriptors. The entire VLAN can operate as a single ring, with frames switched between ports within a single TrCRF.

You can specify the maximum hop count for All-Routes and Spanning Tree Explorer frames for each TrCRF. When you specify the maximum hop count, you limit the maximum number of hops an explorer is allowed to traverse. If a port determines that the explorer frame it is receiving has traversed more than the number of hops specified, it does not forward the frame. The TrCRF determines the number of hops an explorer has traversed by the number of bridge hops in the route information field.

If the ISL connection between network devices fails, you can use a backup TrCRF to configure an alternate route for traffic between undistributed TrCRFs. Only one backup TrCRF for a TrBRF is allowed, and only one port per network device can belong to a backup TrCRF.

If the ISL connection between the network devices fails, the port in the backup TrCRF on each affected network device automatically becomes active, rerouting traffic between the undistributed TrCRFs through the backup TrCRF. When the ISL connection is reestablished, all but one port in the backup TrCRF is disabled. Figure 14-4 illustrates the backup TrCRF.

Figure 14-4 Backup TrCRF

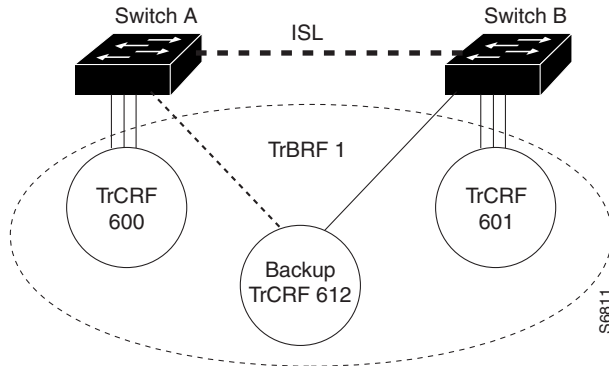

VLAN Default Configuration

Tables 14-2 through 14-6 show the default configurations for the different VLAN media types.

Table 14-2 Ethernet VLAN Defaults and Ranges

Parameter	Default	Range
VLAN ID	1	1–4094
VLAN name	“default” for VLAN 1 “VLANvlan_ID” for other Ethernet VLANs	—
802.10 SAID	10vlan_ID	100001–104094
MTU size	1500	1500–18190
Translational bridge 1	0	0–1005
Translational bridge 2	0	0–1005
VLAN state	active	active, suspend
Pruning eligibility	VLANs 2–1001 are pruning eligible; VLANs 1006–4094 are not pruning eligible.	—

Table 14-3 FDDI VLAN Defaults and Ranges

Parameter	Default	Range
VLAN ID	1002	1–1005
VLAN name	“fddi-default”	—
802.10 SAID	101002	1–4294967294
MTU size	1500	1500–18190
Ring number	0	1–4095
Parent VLAN	0	0–1005
Translational bridge 1	0	0–1005

Table 14-3 FDDI VLAN Defaults and Ranges (continued)

Parameter	Default	Range
Translational bridge 2	0	0–1005
VLAN state	active	active, suspend

Table 14-4 Token Ring (TrCRF) VLAN Defaults and Ranges

Parameter	Default	Range
VLAN ID	1003	1–1005
VLAN name	“token-ring-default”	—
802.10 SAID	101003	1–4294967294
Ring Number	0	1–4095
MTU size	VTPv1 default 1500 VTPv2 default 4472	1500–18190
Translational bridge 1	0	0–1005
Translational bridge 2	0	0–1005
VLAN state	active	active, suspend
Bridge mode	srb	srb, srt
ARE max hops	7	0–13
STE max hops	7	0–13
Backup CRF	disabled	disable; enable

Table 14-5 FDDI-Net VLAN Defaults and Ranges

Parameter	Default	Range
VLAN ID	1004	1–1005
VLAN name	“fddinet-default”	—
802.10 SAID	101004	1–4294967294
MTU size	1500	1500–18190
Bridge number	1	0–15
STP type	ieee	auto, ibm, ieee
VLAN state	active	active, suspend

Table 14-6 Token Ring (TrBRF) VLAN Defaults and Ranges

Parameter	Default	Range
VLAN ID	1005	1–1005
VLAN name	“trnet-default”	—
802.10 SAID	101005	1–4294967294

Table 14-6 Token Ring (TrBRF) VLAN Defaults and Ranges (continued)

Parameter	Default	Range
MTU size	VTPv1 1500; VTPv2 4472	1500–18190
Bridge number	1	0–15
STP type	ibm	auto, ibm, ieee
VLAN state	active	active, suspend

VLAN Configuration Guidelines and Restrictions

When creating and modifying VLANs in your network, follow these guidelines and restrictions:

- Supervisor engine redundancy does not support nondefault VLAN data file names or locations. Do not enter the **vtp file** *file_name* command on a router that has a redundant supervisor engine.
- Before installing a redundant supervisor engine, enter the **no vtp file** command to return to the default configuration.
- RPR+ redundancy (see [Chapter 8, “Configuring RPR and RPR+ Supervisor Engine Redundancy”](#)) does not support a configuration entered in VLAN database mode. Use global configuration mode with RPR+ redundancy.
- You can configure extended-range VLANs only in global configuration mode. You cannot configure extended-range VLANs in VLAN database mode. See the [“VLAN Configuration Options” section on page 14-9](#).
- Before you can create a VLAN, the Cisco 7600 series router must be in VTP server mode or VTP transparent mode. For information on configuring VTP, see [Chapter 13, “Configuring VTP.”](#)
- The VLAN configuration is stored in the vlan.dat file, which is stored in nonvolatile memory. You can cause inconsistency in the VLAN database if you manually delete the vlan.dat file. If you want to modify the VLAN configuration or VTP, use the commands described in this guide and in the *Cisco 7600 Series Router Cisco IOS Command Reference* publication.
- To do a complete backup of your configuration, include the vlan.dat file in the backup.
- The Cisco IOS **end** command is not supported in VLAN database mode.
- You cannot enter **Ctrl-Z** to exit VLAN database mode.
- Cisco 7600 series routers do not support Token Ring or FDDI media. The router does not forward FDDI, FDDI-Net, TrCRF, or TrBRF traffic, but it can propagate the VLAN configuration through VTP.
- When a Cisco 7600 series router is configured as a VTP server, you can configure FDDI and Token Ring VLANs from the router.
- You must configure a TrBRF before you configure the TrCRF (the parent TrBRF VLAN you specify must exist).
- In a Token Ring environment, the logical interfaces (the connection between the TrBRF and the TrCRF) of the TrBRF are placed in a blocked state if either of these conditions exists:
 - The TrBRF is running the IBM STP, and the TrCRF is in SRT mode.
 - The TrBRF is running the IEEE STP, and the TrCRF is in SRB mode.

Configuring VLANs

These sections describe how to configure VLANs:

- [VLAN Configuration Options, page 14-9](#)
- [Creating or Modifying an Ethernet VLAN, page 14-10](#)
- [Assigning a Layer 2 LAN Interface to a VLAN, page 14-12](#)
- [Configuring the Internal VLAN Allocation Policy, page 14-12](#)
- [Configuring VLAN Translation, page 14-13](#)
- [Mapping 802.1Q VLANs to ISL VLANs, page 14-16](#)

**Note**

VLANs support a number of parameters that are not discussed in detail in this section. For complete information, refer to the *Cisco 7600 Series Router Cisco IOS Command Reference* publication.

VLAN Configuration Options

These sections describe the VLAN configuration options:

- [VLAN Configuration in Global Configuration Mode, page 14-9](#)
- [VLAN Configuration in VLAN Database Mode, page 14-10](#)

VLAN Configuration in Global Configuration Mode

If the router is in VTP server or transparent mode (see the “[Configuring VTP](#)” section on page 13-6), you can configure VLANs in global and config-vlan configuration modes. When you configure VLANs in global and config-vlan configuration modes, the VLAN configuration is saved in the vlan.dat file. To display the VLAN configuration, enter the **show vlan** command.

If the router is in VLAN transparent mode, the VLAN configuration is saved in the running-config file. Use the copy **running-config startup-config** command to save the VLAN configuration to the startup-config file. After you save the running configuration as the startup configuration, use the **show running-config** and **show startup-config** commands to display the VLAN configuration.

**Note**

- When the router boots, if the VTP domain name and VTP mode in the startup-config and vlan.dat files do not match, the router uses the configuration in the vlan.dat file.
- You can configure extended-range VLANs only in global configuration mode. You cannot configure extended-range VLANs in VLAN database mode.

VLAN Configuration in VLAN Database Mode



Note

- VLAN database mode is supported in releases earlier than Release 12.2(18)SXD.
- You cannot configure extended-range VLANs in VLAN database mode. You can configure extended-range VLANs only in global configuration mode. RPR+ redundancy does not support configuration entered in VLAN database mode. Use global configuration mode with RPR+ redundancy.

If the router is in VTP server or transparent mode, you can configure VLANs in the VLAN database mode. When you configure VLANs in VLAN database mode, the VLAN configuration is saved in the `vlan.dat` files. To display the VLAN configuration, enter the **show vlan** command.

You use the interface configuration command mode to define the port membership mode and add and remove ports from a VLAN. The results of these commands are written to the running-config file, and you can display the file by entering the **show running-config** command.

Creating or Modifying an Ethernet VLAN

User-configured VLANs have unique IDs from 1 to 4094, except for reserved VLANs (see [Table 14-1 on page 14-2](#)). Enter the **vlan** command with an unused ID to create a VLAN. Enter the **vlan** command for an existing VLAN to modify the VLAN (you cannot modify an existing VLAN that is being used by a Layer 3 port or a software feature).

See the “[VLAN Default Configuration](#)” section on [page 14-6](#) for the list of default parameters that are assigned when you create a VLAN. If you do not specify the VLAN type with the **media** keyword, the VLAN is an Ethernet VLAN.

To create or modify a VLAN, perform this task:

	Command	Purpose
Step 1	Router# configure terminal or Router# vlan database	Enters VLAN configuration mode.
Step 2	Router(config)# vlan <i>vlan_ID</i> { [- <i>vlan_ID</i>] [, <i>vlan_ID</i>]} Router(config-vlan)# or Router(vlan)# vlan <i>vlan_ID</i> Router(config)# no vlan <i>vlan_ID</i> Router(config-vlan)# or Router(vlan)# no vlan <i>vlan_ID</i>	Creates or modifies an Ethernet VLAN, a range of Ethernet VLANs, or several Ethernet VLANs specified in a comma-separated list (do not enter space characters). Deletes a VLAN.
Step 3	Router(config-vlan)# end or Router(vlan)# exit	Updates the VLAN database and returns to privileged EXEC mode.
Step 4	Router# show vlan [<i>id</i> <i>name</i>] <i>vlan</i>	Verifies the VLAN configuration.

When you create or modify an Ethernet VLAN, note the following information:

- RPR+ redundancy does not support a configuration entered in VLAN database mode. Use global configuration mode with RPR+ redundancy.
- Because Layer 3 ports and some software features require internal VLANs allocated from 1006 and up, configure extended-range VLANs starting with 4094.
- You can configure extended-range VLANs only in global configuration mode. You cannot configure extended-range VLANs in VLAN database mode.
- Layer 3 ports and some software features use extended-range VLANs. If the VLAN you are trying to create or modify is being used by a Layer 3 port or a software feature, the router displays a message and does not modify the VLAN configuration.

When deleting VLANs, note the following information:

- You cannot delete the default VLANs for the different media types: Ethernet VLAN 1 and FDDI or Token Ring VLANs 1002 to 1005.
- When you delete a VLAN, any LAN ports configured as access ports assigned to that VLAN become inactive. The ports remain associated with the VLAN (and inactive) until you assign them to a new VLAN.

This example shows how to create an Ethernet VLAN in global configuration mode and verify the configuration:

```
Router# configure terminal
Router(config)# vlan 3
Router(config-vlan)# end
Router# show vlan id 3
```

VLAN Name	Status	Ports
3 VLAN0003	active	

VLAN Type	SAID	MTU	Parent	RingNo	BridgeNo	Stp	BrdgMode	Trans1	Trans2
3 enet	100003	1500	-	-	-	-	-	0	0

Primary	Secondary	Type	Interfaces

This example shows how to create an Ethernet VLAN in VLAN database mode:

```
Router# vlan database
Router(vlan)# vlan 3
VLAN 3 added:
  Name: VLAN0003
Router(vlan)# exit
APPLY completed.
Exiting....
```

This example shows how to verify the configuration:

```
Router# show vlan name VLAN0003
```

VLAN Name	Status	Ports
3 VLAN0003	active	

VLAN Type	SAID	MTU	Parent	RingNo	BridgeNo	Stp	Trans1	Trans2
3 enet	100003	1500	-	-	-	-	0	0

```
Router#
```

Assigning a Layer 2 LAN Interface to a VLAN

A VLAN created in a management domain remains unused until you assign one or more LAN ports to the VLAN.

Note

Make sure you assign LAN ports to a VLAN of the appropriate type. Assign Ethernet ports to Ethernet-type VLANs.

To assign one or more LAN ports to a VLAN, complete the procedures in the [“Configuring LAN Interfaces for Layer 2 Switching”](#) section on page 10-6.

Configuring the Internal VLAN Allocation Policy

For more information about VLAN allocation, see the [“VLAN Ranges”](#) section on page 14-2.

Note

The internal VLAN allocation policy is applied only following a reload.

To configure the internal VLAN allocation policy, perform this task:

	Command	Purpose
Step 1	Router(config)# vlan internal allocation policy { ascending descending }	Configures the internal VLAN allocation policy.
	Router(config)# no vlan internal allocation policy	Returns to the default (ascending).
Step 2	Router(config)# end	Exits configuration mode.
Step 3	Router# reload	Applies the new internal VLAN allocation policy.
		 Caution You do not need to enter the reload command immediately. Enter the reload command during a planned maintenance window.

When you configure the internal VLAN allocation policy, note the following information:

- Enter the **ascending** keyword to allocate internal VLANs from 1006 and up.
- Enter the **descending** keyword to allocate internal VLAN from 4094 and down.

This example shows how to configure descending as the internal VLAN allocation policy:

```
Router# configure terminal
Router(config)# vlan internal allocation policy descending
```

Configuring VLAN Translation

On trunk ports, you can translate one VLAN number to another VLAN number, which transfers all traffic received in one VLAN to the other VLAN.

These sections describe VLAN translation:

- [VLAN Translation Guidelines and Restrictions, page 14-13](#)
- [Configuring VLAN Translation on a Trunk Port, page 14-15](#)
- [Enabling VLAN Translation on Other Ports in a Port Group, page 14-15](#)



Note

- Release 12.2(17b)SXA and later releases support VLAN translation.
- To avoid spanning tree loops, be careful not to misconfigure the VLAN translation feature.

VLAN Translation Guidelines and Restrictions

When translating VLANs, follow these guidelines and restrictions:

- A VLAN translation configuration is inactive if it is applied to ports that are not Layer 2 trunks.
- Do not configure translation of ingress native VLAN traffic on an 802.1Q trunk. Because 802.1Q native VLAN traffic is untagged, it cannot be recognized for translation. You can translate traffic from other VLANs to the native VLAN of an 802.1Q trunk.
- Do not remove the VLAN to which you are translating from the trunk.
- The VLAN translation configuration applies to all ports in a port group. VLAN translation is disabled by default on all ports in a port group. Enable VLAN translation on ports as needed.
- The following table lists:
 - The modules that support VLAN translation
 - The port groups to which VLAN translation configuration applies
 - The number of VLAN translations supported by the port groups
 - The trunk types supported by the modules



Note

LAN ports on OSMs support VLAN translation. LAN ports on OSMs are in a single port group.

Product Number	Number of Ports	Number of Port Groups	Port Ranges per Port Group	Translations per Port Group	VLAN Translation Trunk-Type Support
WS-SUP720-3BXL WS-SUP720-3B WS-SUP720	2	1	1–2	32	802.1Q
WS-SUP32-10GE	3	2	1, 2–3	16	ISL 802.1Q

Product Number	Number of Ports	Number of Port Groups	Port Ranges per Port Group	Translations per Port Group	VLAN Translation Trunk-Type Support
WS-SUP32-GE	9	1	1–9	16	ISL 802.1Q
WS-X6K-S2U-MSFC2 WS-X6K-S2-MSFC2	2	1	1–2	32	802.1Q
WS-X6704-10GE	4	4	1 port in each group	128	ISL 802.1Q
WS-X6502-10GE	1	1	1 port in 1 group	32	802.1Q
WS-X6724-SFP	24	2	1–12 13–24	128	ISL 802.1Q
WS-X6816-GBIC	16	2	1–8 9–16	32	802.1Q
WS-X6516A-GBIC	16	2	1–8 9–16	32	802.1Q
WS-X6516-GBIC	16	2	1–8 9–16	32	802.1Q
WS-X6748-GE-TX	48	4	1–12 13–24 25–36 37–48	128	ISL 802.1Q
WS-X6516-GE-TX	16	2	1–8 9–16	32	802.1Q
WS-X6524-100FX-MM	24	1	1–24	32	ISL 802.1Q
WS-X6548-RJ-45	48	1	1–48	32	ISL 802.1Q
WS-X6548-RJ-21	48	1	1–48	32	ISL 802.1Q

**Note**

To configure a port as a trunk, see the [“Configuring a Layer 2 Switching Port as a Trunk”](#) section on page 10-7.

Configuring VLAN Translation on a Trunk Port

To translate VLANs on a trunk port, perform this task:

	Command	Purpose
Step 1	Router(config)# interface <i>type</i> ¹ <i>slot/port</i>	Selects the Layer 2 trunk port to configure.
Step 2	Router(config-if)# switchport vlan mapping enable	Enables VLAN translation.
Step 3	Router(config-if)# switchport vlan mapping <i>original_vlan_ID translated_vlan_ID</i>	Translates a VLAN to another VLAN. The valid range is 1 to 4094.
	Router(config-if)# no switchport vlan mapping { all <i>original_vlan_ID translated_vlan_ID</i> }	Deletes the mapping.
Step 4	Router(config-if)# end	Exits configuration mode.
Step 5	Router# show interface <i>type</i> ¹ <i>slot/port</i> vlan mapping	Verifies the VLAN mapping.

1. *type* = ethernet, fastethernet, gigabitethernet, or tengigabitethernet

This example shows how to map VLAN 1649 to VLAN 755 Gigabit Ethernet port 5/2:

```
Router# configure terminal
Router(config)# interface gigabitethernet 5/2
Router(config-if)# switchport vlan mapping 1649 755
Router(config-if)# end
Router#
```

This example shows how to verify the configuration:

```
Router# show interface gigabitethernet 5/2 vlan mapping
State: enabled
Original VLAN Translated VLAN
-----
      1649           755
```

Enabling VLAN Translation on Other Ports in a Port Group

To enable VLAN translation on other ports in a port group, perform this task:

	Command	Purpose
Step 1	Router(config)# interface <i>type</i> ¹ <i>slot/port</i>	Selects the LAN port to configure.
Step 2	Router(config-if)# switchport vlan mapping enable	Enables VLAN translation.
	Router(config-if)# no switchport vlan mapping enable	Disables VLAN translation.
Step 3	Router(config-if)# end	Exits configuration mode.
Step 4	Router# show interface <i>type</i> ¹ <i>slot/port</i> vlan mapping	Verifies the VLAN mapping.

1. *type* = ethernet, fastethernet, gigabitethernet, or tengigabitethernet

This example shows how to enable VLAN translation on a port:

```
Router# configure terminal
Router(config)# interface gigabitethernet 5/2
Router(config-if)# switchport vlan mapping enable
Router(config-if)# end
Router#
```

Mapping 802.1Q VLANs to ISL VLANs

The valid range of user-configurable ISL VLANs is 1 through 1001 and 1006 through 4094. The valid range of VLANs specified in the IEEE 802.1Q standard is 1 to 4094. You can map 802.1Q VLAN numbers to ISL VLAN numbers.

802.1Q VLANs in the range 1 through 1001 and 1006 through 4094 are automatically mapped to the corresponding ISL VLAN. 802.1Q VLAN numbers corresponding to reserved VLAN numbers must be mapped to an ISL VLAN in order to be recognized and forwarded by Cisco network devices.

These restrictions apply when mapping 802.1Q VLANs to ISL VLANs:

- You can configure up to eight 802.1Q-to-ISL VLAN mappings on the Cisco 7600 series router.
- You can only map 802.1Q VLANs to Ethernet-type ISL VLANs.
- Do not enter the native VLAN of any 802.1Q trunk in the mapping table.
- When you map an 802.1Q VLAN to an ISL VLAN, traffic on the 802.1Q VLAN corresponding to the mapped ISL VLAN is blocked. For example, if you map 802.1Q VLAN 1007 to ISL VLAN 200, traffic on 802.1Q VLAN 200 is blocked.
- VLAN mappings are local to each Cisco 7600 series router. Make sure you configure the same VLAN mappings on all appropriate network devices.

To map an 802.1Q VLAN to an ISL VLAN, perform this task:

	Command	Purpose
Step 1	Router(config)# vlan mapping dot1q <i>dot1q_vlan_ID</i> isl <i>isl_vlan_ID</i>	Maps an 802.1Q VLAN to an ISL Ethernet VLAN. The valid range for <i>dot1q_vlan_ID</i> is 1001 to 4094. The valid range for <i>isl_vlan_ID</i> is the same.
	Router(config)# no vlan mapping dot1q { all <i>dot1q_vlan_ID</i> }	Deletes the mapping.
Step 2	Router(config)# end	Exits configuration mode.
Step 3	Router# show vlan	Verifies the VLAN mapping.

This example shows how to map 802.1Q VLAN 1003 to ISL VLAN 200:

```
Router# configure terminal
Router(config)# vlan mapping dot1q 1003 isl 200
Router(config)# end
Router#
```

This example shows how to verify the configuration:

```
Router# show vlan
<...output truncated...>
802.1Q Trunk Remapped VLANs:
802.1Q VLAN      ISL VLAN
-----
      1003          200
```

