



CHAPTER 3

Setting Up the Physical Network

Before you can use VFrame, you must set up the devices that you want to manage with it in very specific ways. These topics describe the type of network setup required and how you must configure each type of device. Complete this setup before discovering the devices in VFrame.

- [Understanding the Expected Network Setup, page 3-1](#)
- [Understanding Types of Devices, page 3-3](#)
- [Setting Up Required Features in the Physical Network, page 3-11](#)
- [Next Steps, page 3-30](#)

Understanding the Expected Network Setup

The VFrame Data Center network contains the VFrame Data Center Director and network devices, storage devices, and servers.

Network devices include Ethernet switches and service modules (see [Network Devices, page 3-3](#)).

Storage devices include network-attached storage (NAS) filers (also called NFS servers) and storage area network (SAN) devices such as MDS switches, storage arrays, and storage managers (see [Storage Devices, page 3-4](#)).

Servers include VFrame-managed application servers, model servers, and lights-out management (LOM) managers (see [Servers, page 3-9](#)).

In a typical data center environment, most of the devices are configured for high availability (HA), which means that two devices are configured as a redundant pair. Redundancy ensures that if the primary device fails, a backup device takes over immediately.

Figure 3-1 is a highly-simplified example of a data center network.

Figure 3-1 Sample Data Center Network

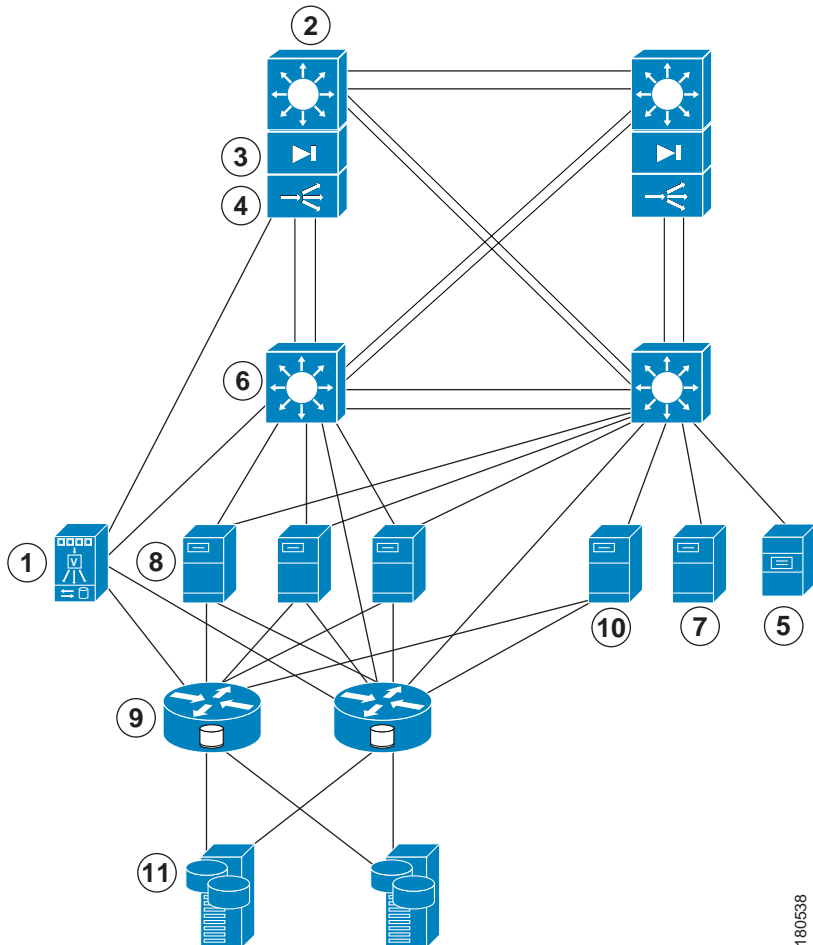

180538

1	VFrame Data Center Director	7	LOM manager
2	Ethernet switch with service modules	8	Servers
3	Firewall Services Module (FWSM)	9	MDS switch
4	Content Switching Module (CSM)	10	Storage manager
5	NAS filer	11	Storage array
6	Ethernet switch without service modules		

Understanding Types of Devices

The following topics describe the type of devices that VFrame can manage:

- [Network Devices, page 3-3](#)
- [Storage Devices, page 3-4](#)
- [Servers, page 3-9](#)

Network Devices

Network devices can include Ethernet switches and the service modules that they host, if any. Service modules, such as the Firewall Services Module (FWSM) or Content Switching Module (CSM), provide network services such as firewall and load balancing.

For details, see the documentation for the Ethernet switch or service module.

For high-level setup tasks that enable you to use the Ethernet switch and service modules with VFrame, see [Setting Up Ethernet Switches, page 3-11](#) and [Setting Up Network Services, page 3-13](#).

Storage Devices

A data center network can include the following types of storage devices: network-attached storage (NAS) filers, storage area network (SAN) fabric devices, and storage managers. The following topics provide more information:

- [NAS Filers, page 3-4](#)
- [SAN Fabric Devices, page 3-5](#)
- [Storage Managers, page 3-5](#)
- [Fabric Mode and Storage Array Mode, page 3-6](#)

NAS Filers

A network-attached storage (NAS) filer is a dedicated, file-based, data storage device that you can connect directly to a network to provide centralized data access and storage to heterogeneous network clients. They are sometimes called NFS servers.

NAS filers support two types of file-based protocols: Network File System (NFS) and Common Internet File System (CIFS). The NFS protocol is used by clients running the Linux operating system. The CIFS protocol is used by clients running the Windows operating system.

As part of setup, the storage administrator creates volumes on one or more NAS filers to meet VFrame's operational needs. During discovery, attributes associated with the NAS filer, such as its volumes, are discovered and added to the storage inventory. VFrame uses this inventory to provision storage resources to servers in service networks.

For details, see the documentation for the NAS filer. For high-level setup tasks that enable you to use the NAS filer with VFrame, see [Setting Up NAS Filers, page 3-16](#).

SAN Fabric Devices

A storage area network (SAN) is a network designed to attach computer storage devices to servers. SAN fabric devices are based on Fibre Channel interconnections. VFrame supports the following types of SAN fabric devices:

- [MDS Switches, page 3-5](#)
- [Storage Arrays, page 3-5](#)

MDS Switches

VFrame discovers the Fibre Channel devices in a SAN fabric through an MDS switch. As part of setup, the storage administrator creates one or more virtual storage area networks (VSANs) and assigns Fibre Channel target devices (MDS switches) to it. During discovery, attributes associated with the SAN devices, such as its VSANs and logical unit numbers (LUNs), are collected and used to generate an inventory. VFrame uses this inventory to provision storage resources to servers in service networks.

For details, see the documentation for the MDS switch. For high-level setup tasks that enable you to use the MDS switch with VFrame, see [Setting Up MDS Switches, page 3-16](#).

Storage Arrays

A storage array is an enterprise storage system that contains multiple disk drives. A storage array has a cache and intelligence to perform functions such as Redundant Array of Independent Disks (RAID) and virtualization.

Storage Managers

Storage managers are devices that contain third-party client applications, such as those required by Clariion, Hitachi, and Symmetrix storage arrays. These applications enable you to secure and manage your storage arrays. You can decide which LUNs and which ports should be visible to a particular server.

Before you run discovery to discover storage arrays and their components through storage managers, you must define the storage manager in VFrame. You define the storage manager based on a storage manager template, which identifies the

macros that will be run to execute the storage manager's commands on the storage manager. If VFrame's predefined templates work for your storage manager application, you do not need to create your own storage manager templates.

If you do need to create a customized storage manager template to define your storage manager, you will probably need to create additional macros. Through macros, you control the LUNs and ports that should be visible to a particular server. You can use these macros for inventory, for LUN masking and unmasking, and for LUN mapping and unmapping tasks. For details about storage manager templates, see [Storage Manager Templates, page 11-73](#).

For high-level setup tasks that enable you to use Storage Managers with VFrame, see [Setting Up Storage Managers, page 3-18](#).

Fabric Mode and Storage Array Mode

You can manage the SAN fabric devices in two ways:

- Fabric mode—Using SAN fabric devices (MDS switches) and storage arrays.
- Storage array mode—Using SAN fabric devices (MDS switches), storage managers, and storage arrays.

When you set up VFrame, you can choose whether you want to manage your SAN in fabric mode or in storage array mode.

Fabric Mode

If you manage your SAN in fabric mode (through an MDS switch), security on the storage arrays is turned off and all the LUNs in the storage arrays are visible to the MDS switch and to the VFrame Data Center Director.

In fabric mode, the MDS switch performs LUN-based zoning to make the LUNs visible to the server. You do not discover the storage arrays or manage them.

[Figure 3-2](#) shows a SAN managed in fabric mode.

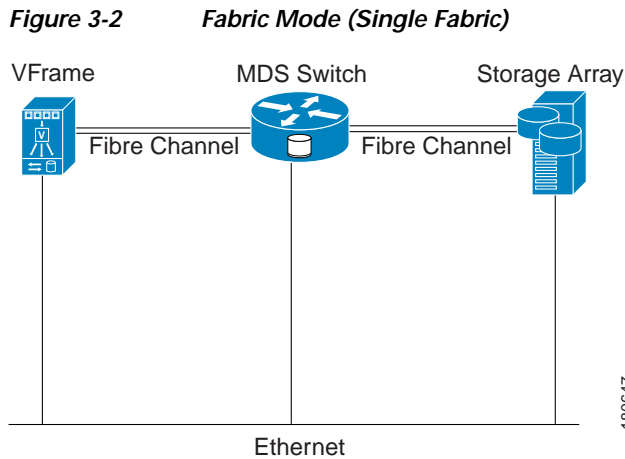

Storage Array Mode

If you manage your SAN in storage array mode (through an MDS switch and a storage manager), security on the storage arrays is turned on. You can decide which LUNs and which ports should be visible to a particular server.

In storage array mode, the MDS switch performs target-based zoning to make just the target ports visible to the server.

You can configure storage managers and storage arrays by using two types of configuration paths: Fibre Channel or Ethernet.

[Figure 3-3](#) shows the storage managers and storage arrays configured with a Fibre Channel configuration path. The storage manager connects to the storage array by means of an MDS switch using Fibre Channels.

Figure 3-3 Storage Array Mode—Fibre Channel Configuration Path

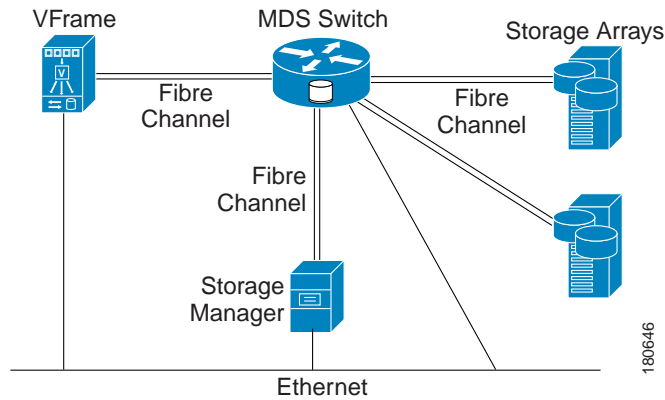
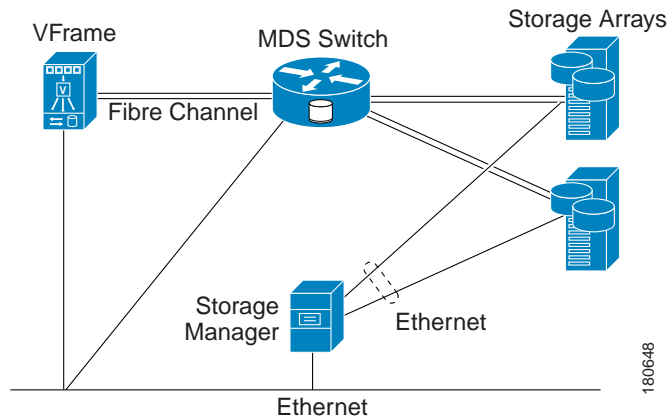

Figure 3-4 shows the storage managers and storage arrays configured with the Ethernet configuration path. The storage manager is connected to the storage array using Ethernet.

Figure 3-4 Storage Array Mode—Ethernet Configuration Path



Servers

A data center network will include application servers, model servers, and LOM managers to control the servers. The following topics provide more information:

- [Model and Application Servers, page 3-9](#)
- [LOM Managers, page 3-10](#)

Model and Application Servers

VFrame places servers in two categories: model servers and application servers.

- Model servers are servers from which you create a snapshot of a golden image. The golden image is an image of the operating system and of the applications you want to run on the application servers.
- Application servers are servers on which you deploy the golden images. These are the servers that participate in service networks, the ones users connect to when using an application.

To enable VFrame to manage the servers, you must configure the servers to do a PXE boot, and the servers must have a LOM interface. Because different types of servers have different types of LOM interfaces, VFrame uses LOM managers to control the power management and inventory of the servers (see [LOM Managers, page 3-10](#)).

For high-level setup tasks that enable you to use the servers with VFrame, see [Setting Up Servers, page 3-20](#).

LOM Managers

LOM managers are devices that provide VFrame the ability to manage LOM interfaces on different types of servers. A LOM manager could be one of the following:

- The VFrame Data Center Director—You can treat the VFrame Data Center Director as the LOM manager in situations when a simple SSH or Telnet command-line utility is needed to communicate with the LOM interface. For example, you can use SSH or Telnet to communicate with HP iLO and IBM RSA2 Slimline.
- An external Linux device that contains the necessary third-party client software and configuration—In some situations, you might need third-party client software to communicate with the LOM interfaces. For example, Dell uses the racadm utility to communicate with DRAC. IBM uses the smbridge utility to communicate with BMC. In such situations, you must install the required software on an external Linux device and treat that device as the LOM manager.

VFrame uses LOM managers and LOM configuration macros to control the power (on or off) of the servers. For VFrame to manage the servers, you must either create LOM manager templates or use the predefined templates to define the power on, power off, power status, and inventory macros. You then must define a LOM manager to execute these macros. After you complete these tasks, VFrame runs the macros on the specified LOM manager to retrieve a list of LOM interfaces associated with the physical servers, to power on and power off the servers, and to obtain the power status of the servers. For details about LOM manager templates, see [LOM Manager Templates, page 11-81](#).

For high-level setup tasks that enable you to use LOM managers with VFrame, see these topics:

- [Configuring VFrame as a LOM Manager, page 3-26](#)
- [Setting Up Independent LOM Managers, page 3-28](#).

Setting Up Required Features in the Physical Network

These topics provide high-level guidelines for setting up each type of device in your network:

- [Setting Up Ethernet Switches, page 3-11](#)
- [Setting Up Network Services, page 3-13](#)
- [Setting Up Storage Devices, page 3-15](#)
- [Setting Up Servers, page 3-20](#)

Setting Up Ethernet Switches

You must set up the Ethernet switch in specific ways before you can manage it with VFrame. The following procedure describes the high-level setup tasks.

For details, see the documentation for the Ethernet switch.

Procedure

-
- Step 1** Verify that the Ethernet switch is running the correct Cisco IOS software release (see Supported Devices in *Release Notes for Cisco VFrame Data Center 1.1*).
 - Step 2** Configure the username, password, and enable password for logging into the Ethernet switch.
 - Step 3** Configure and enable SSH version 1 on the switch so that the VFrame can connect to it.
-  **Note** VFrame supports SSH version 1 only.
-
- Step 4** Enable Cisco Discovery Protocol (CDP).

Step 5 Configure SNMP read community strings.



Tip

Cisco recommends that you do not use the same string for more than one purpose. For example, if you configure **xyz259** as the read community string, do not also configure **xyz259** as the trap community string. If you configure the same string name for read and trap, and then disable the read string, VFrame cannot identify that the problem it has accessing your switch is due to the lack of a read community string, and will label the switch's modules as missing.

Step 6 Make sure that no firewalls are blocking the CDP and SNMP packets.

Step 7 If the VFrame Data Center Director and servers are on different subnets, configure the DHCP relay agent on the Ethernet switch (see [Configuring DHCP Relay Agents in Ethernet Switches, page 5-4](#)).

Step 8 Make sure that the Ethernet switch is connected to the network and can be reached (pinged) from the VFrame Data Center Director.

Step 9 Configure every port that is connected to a server with these commands, where *vlanID* is a VLAN that VFrame will manage:

```
switchport
switchport access vlan vlanID
no ip address
```

Configuring the port as a switch port is required to ensure that VFrame can manage the server attached to it. Otherwise, VFrame cannot obtain the correct MAC address for the server.

Step 10 Determine whether the switch or any service modules have non-default command prompts configured. The default prompts are > and #.

If you configure your devices to use different prompts, you must identify the prompts to VFrame. From the VFrame GUI, select **File > System Settings**, and then select the **System Preferences** tab. Click in the **CLI Prompts** data field and add your prompts, separating prompts with a comma or space (or both).



Tip

If you do not identify non-default prompts, VFrame will have trouble during SSH connections to the device. This will affect discovery, management, and use of the device.

- Step 11** Verify that the banners for the switch or service modules do not use any of the following reserved phrases or characters:
- Password
 - Password:
 - (enable)
 - :
 - %
 -]
 - ?
- Step 12** (Optional) Configure the switch for HA.
-

Related Topics

- [Understanding the Expected Network Setup, page 3-1](#)
- [Network Devices, page 3-3](#)

Setting Up Network Services

You must set up the Ethernet switch's service modules before you can use them in VFrame. These topics describe how to set up the service modules you can manage with VFrame:

- [Setting Up FWSM, page 3-13](#)
- [Setting Up CSM, page 3-15](#)

Setting Up FWSM

You must set up the Firewall Services Module (FWSM) in specific ways before you can use it in VFrame. The following procedure describes the high-level setup tasks.

For details, see the documentation for the FWSM.

Procedure

- Step 1** Verify that the FWSM is running the correct software release (see Supported Devices in *Release Notes for Cisco VFrame Data Center 1.1*).
- If you are configuring two FWSMs for HA, both FWSMs must have the same major and minor software release numbers.
- Step 2** Enable multi-mode.
- Step 3** (Optional) Configure the FWSMs for HA.
- Step 4** If you are configuring two FWSMs for HA, from the active FWSM, create an Admin context.
- Step 5** Configure the interface in Admin context with the IP address.
- Step 6** Enable SSH for the IP address.
- Step 7** Make sure that the FWSM can be reached from the VFrame Data Center Director (you can make an SSH connection to the IP address).
- Step 8** Create the security contexts you want to use and specify the firewall mode (routed or transparent).
- Step 9** Determine whether the service module has non-default command prompts configured. The default prompts are > and #.
- If you configure your service module to use different prompts, you must identify the prompts to VFrame. From the VFrame GUI, select **File > System Settings**, and then select the **System Preferences** tab. Click in the **CLI Prompts** data field and add your prompts, separating prompts with a comma or space (or both).
-  **Tip** If you do not identify non-default prompts, VFrame will have trouble during SSH connections to the service module. This will affect discovery, management, and use of the module.
-
- Step 10** (Optional) If you are using Active/Active failover, create the required two failover groups and assign each security context to one of them.
-

Related Topics

- [Understanding the Expected Network Setup, page 3-1](#)
- [Network Devices, page 3-3](#)

Setting Up CSM

You must set up the CSM in specific ways before you can use it in VFrame. The following procedure describes the high-level setup tasks.

For details, see the documentation for the CSM.

Procedure

-
- | | |
|--------|--|
| Step 1 | Verify that the CSM is running the correct software release (see Supported Devices in <i>Release Notes for Cisco VFrame Data Center 1.1</i>). |
| Step 2 | (Optional) Configure the CSM for HA. |
-

Related Topics

- [Understanding the Expected Network Setup, page 3-1](#)
- [Network Devices, page 3-3](#)

Setting Up Storage Devices

These topics describe how to set up each type of storage device:

- [Setting Up NAS Filers, page 3-16](#)
- [Setting Up MDS Switches, page 3-16](#)
- [Setting Up Storage Managers, page 3-18](#)
- [Setting Up Storage Arrays, page 3-19](#)

Setting Up NAS Filers

You must set up the NAS filer in specific ways before you can use it in VFrame. The following procedure describes the high-level setup tasks.

VFrame supports NAS filers made only by Network Appliances.

For details, see the documentation for the NAS filer.

Procedure

- Step 1** Verify that the NAS filer is running the correct DataONTAP release (see Supported Devices in *Release Notes for Cisco VFrame Data Center 1.1*).
- Step 2** Configure the IP address or DNS hostname on the filer.
- Step 3** Configure the username and password for logging into the filer.
- Step 4** Create volumes in the NAS filer.
- Step 5** Enable SSL.
- Step 6** Enable NFS to support clients using the Linux operating system.
- Step 7** Enable CIFS to support clients using the Windows operating system.
- Step 8** Enable HTTP.
- Step 9** Make sure that the NAS filer is connected to the network and can be reached (pinged) from the VFrame Data Center Director.

For details, see the *Data ONTAP Software Setup Guide*.

Related Topics

- [Understanding the Expected Network Setup, page 3-1](#)
- [NAS Filers, page 3-4](#)

Setting Up MDS Switches

You must set up the MDS switch in specific ways before you can use it in VFrame. The following procedure describes the high-level setup tasks.

For details, see the documentation for the MDS switch.

Procedure

-
- Step 1** Verify that the MDS switch is running the correct SAN OS release (see Supported Devices in the *Release Notes for Cisco VFrame Data Center 1.1*).
- Step 2** If you are managing your SAN in fabric-mode, make sure that the MDS switches:
- Support LUN-based zoning.
 - Have the ENTERPRISE_PKG license installed on them and that the license is active.
- Step 3** From the static port VSAN mode, configure the VSANs that will be managed by VFrame.



Note In a physical fabric, you can only have one instance of each VSAN to be managed by VFrame. You cannot have isolated VSAN islands with the same VSAN ID in a physical fabric.

- Step 4** Make sure that there are no existing zones or zone sets in the VSANs that will be managed by VFrame.

We recommend that you do not make external changes to managed VSANs. If you do, you must run discovery again to refresh the data.

You can create zones for a remote golden image repository (GIR). When you do, you must run discovery again to refresh the data.

- Step 5** Enable full zone or zone set distribution.
- Step 6** For a multiple-VSAN configuration, do the following:

- a. Enable inter-VSAN routing (IVR).
- b. Configure IVR to allow connectivity between VFrame and all target ports.



Note Do not configure server ports (required for SAN provisioning) on isolated VSANs. VFrame will not discover connectivity information of server or storage ports on isolated VSANs.

- Step 7** Configure read and write SNMP version 1 community strings on the MDS switch.
- Step 8** Make sure that the MDS switch is connected to the network and can be reached (pinged) from the VFrame Data Center Director.
-

Related Topics

- [Understanding the Expected Network Setup, page 3-1](#)
- [SAN Fabric Devices, page 3-5](#)

Setting Up Storage Managers

A storage manager is a management station that runs software for configuring storage arrays. If you are using a storage manager to manage storage arrays, you must set up the storage manager in specific ways before you can use it in VFrame. The following procedure describes the high-level setup tasks.

For details, see the documentation for the storage manager application.

Procedure

- Step 1** Verify that the correct operating system is installed in the storage manager.
- Step 2** Verify that the Bash shell is installed in the storage manager.
- Step 3** Enable SSH. VFrame uses SSH to communicate with the storage manager.
- Step 4** Do one of the following:
- Use an MDS switch to connect the storage manager to the storage array ([Figure 3-3](#)).
Some third-party client software, such as Symmetrix, requires Fibre Channel connectivity.
 - Use Ethernet to connect the storage manager to the storage array ([Figure 3-4](#)).
Some third-party client software, such as Clariion, require Ethernet connectivity.
- Step 5** Make sure that the storage manager is connected to the network and can be reached (pinged) from the VFrame Data Center Director.

- Step 6** During VFrame installation, when the following prompt appears, answer **Yes**:
- Manage storage arrays through storage array macros? Answering "no" will require LUN zoning on MDS with storage array security turned off. (yes/no) [yes]?
- Step 7** Before you run discovery to discover storage arrays and their components through storage managers, you must do the following:
- Create storage manager templates if the predefined templates do not suit your needs (see [Creating and Modifying Storage Manager Templates, page 11-77](#)).
 - Define the storage managers for the storage manager templates (see [Defining Storage Managers, page 11-80](#)).
 - Configure the storage manager credentials in VFrame (see [Configuring Storage Manager Credentials, page 4-13](#)).
 - Run discovery to discover storage arrays and their components through storage managers (see [Discovering Storage Arrays and Their Components Through Storage Managers, page 6-11](#)).



Note You must know the CLI commands to communicate with the storage manager application.

Related Topics

- [Understanding the Expected Network Setup, page 3-1](#)
- [SAN Fabric Devices, page 3-5](#)
- [Storage Managers, page 3-5](#)
- [Storage Arrays, page 3-5](#)

Setting Up Storage Arrays

You must set up the storage arrays in specific ways before you can use them in VFrame. The following procedure describes the high-level setup tasks.

For details, see the documentation for the storage array.

**Note**

- VFrame does not map LUNs to storage array Fibre Channel ports.
- VFrame does not manage LUNs that are not in use, therefore, you are required to manage them.
- We recommend that you do not externally mask the managed LUNs.

Procedure

-
- Step 1** Map all the required LUNs to the appropriate storage array Fibre Channel ports (with dual-fabric and multiple path requirements).
- Step 2** If you are using storage array in fabric mode, make sure that all the storage arrays are in open, nonsecure mode, or that they have ACLs configured on them to make them appear to be open and nonsecure.
-

Setting Up Servers

These topics describe how to set up servers:

- [Setting Up Application Servers, page 3-20](#)
- [Setting Up Model Servers, page 3-23](#)
- [Creating the LOM Interface and Application Server Inventory File, page 3-24](#)
- [Configuring VFrame as a LOM Manager, page 3-26](#)
- [Setting Up Independent LOM Managers, page 3-28](#)

Setting Up Application Servers

You must set up the servers in specific ways before you can use them in VFrame. The following procedure describes the high-level setup tasks.

For details, see the documentation for the servers.

Before You Begin

- If the server has multiple network interface cards (NICs), make sure that at least one NIC is configured to do PXE boot.
- The server must have a lights-out management (LOM) interface.

Procedure

-
- Step 1** Configure the server BIOS boot order to PXE boot first. Any other boot options (such as booting from an HBA) must come after PXE boot.
- Step 2** Do the following on the LOM interface:
- a. Configure the static or dynamic IP address for the LOM interface.
-  **Note** You can configure a static or a dynamic IP address for the LOM interface, but after it is reported in VFrame through LOM manager discovery, we recommend that you do not change it. If you change it, you must run the LOM manager discovery again.
-
- b. Configure the username and password for logging into the LOM interface.
 - c. Configure the default gateway.
- Step 3** If the server is used in SAN-based deployment, verify the following:
- a. The server is connected to at least one physical fabric that VFrame can discover.
 - b. The server is connected to an MDS switch that has all the managed VSANs in the physical fabric.
 - c. The VFrame Data Center Director is connected to a VSAN that will be managed in each physical fabric.
- Step 4** If you are using SAN management in fabric mode, make sure that the HBA port on your server is a Qlogic or Emulex model (see Supported Devices in the *Release Notes for Cisco VFrame Data Center 1.1*).
- Step 5** To SAN-boot a Qlogic-based server:
- a. Enable HBA BIOS.
 - b. Disable selectable boot setting.

- c. Change the system BIOS boot controller order to boot from the Fibre Channel HBA before other options (such as local disk).



Note Make sure that PXE boot is the first item in the boot order list.

Step 6 To SAN-boot an Emulex-based server:

- a. Enable BIOS using lptutil from a live Linux CD.
- b. Enable Auto scan in BIOS.
- c. Select **Boot Any LUN**.

Step 7 Attach the server to a port on an Ethernet switch that VFrame will manage. You will not be able to manage a server that is attached to an unmanaged device. Do one of the following:

- Connect the server to the same network (VLAN) to which the VFrame server communication interface is connected. This enables VFrame to discover the server by responding to its DHCP request during PXE boot.
- If the VFrame Data Center Director and the server are on different networks (VLANs), use a DHCP relay agent to forward the DHCP requests from the server to the VFrame server communication interface, otherwise, VFrame will not discover the server.

Step 8 (Optional) If you are configuring servers for HA, make sure that the two servers are configured on the same VLAN.

Related Topics

- [Understanding the Expected Network Setup, page 3-1](#)
- [Servers, page 3-9](#)

Setting Up Model Servers

You must set up the model servers in specific ways before you can use them in VFrame. The following procedure describes the high-level setup tasks.

Before you Begin

- You can select an application server to be a model server if it meets these requirements:
 - The server has a single boot partition.
 - A single operating system is installed on the server. VFrame does not support dual boot configurations.
 - The server does not have dynamic disks.
 - The server does not support Linux Volume Manager (LVM).
- If the server has multiple network interface cards (NICs), make sure that at least one NIC can be configured to do PXE boot.
- It is optional that the server have a lights-out management (LOM) interface. If your server has a LOM interface, you can configure it as described in [Setting Up Application Servers, page 3-20](#).

For details on configuring the server and operating system, see the documentation for the server.

Procedure

-
- Step 1** You do not have to configure the server to do PXE boot by default. If your server defaults to another type of boot (such as from local disk), you must be able to select PXE boot during server boot-up so that VFrame can respond to the PXE boot. This is required when you create a golden image from the model server.
- Step 2** If you are using the model server to create images for SAN-based deployment, verify the following:
- a. The HBA port is supported by VFrame (see Supported Devices in *Release Notes for Cisco VFrame Data Center 1.1*).
 - b. The server has the appropriate HBA drivers available in its base operating system, including any required multipathing software for multiple or alternate path configurations.

- Step 3** Install the VFrame host agent on to the model server (see [Installing the VFrame Host Agent on Model Servers, page 8-6](#)).
- Step 4** If the interface on which the server can PXE boot is not connected to the same VLAN or subnet as the VFrame Data Center Director, configure a DHCP helper for the server's VLAN to forward the PXE boot request to VFrame. For information, see [Configuring DHCP Relay Agents in Ethernet Switches, page 5-4](#).
- Step 5** Verify that the server is connected to the network and can be reached (pinged) from the VFrame Data Center Director.
-

Related Topics

- [Understanding the Expected Network Setup, page 3-1](#)
- [Servers, page 3-9](#)
- [Installing the VFrame Host Agent on Model Servers, page 8-6](#)

Creating the LOM Interface and Application Server Inventory File

To discover and manage application servers, VFrame must have information about the server LOM interfaces. VFrame uses the LOM interface to control the server's power settings. VFrame uses the LOM inventory macro in a LOM manager template to obtain the required LOM interface information from a LOM manager.

If you create your own custom LOM manager template, you can design the LOM inventory macro to obtain the required LOM interface information from the data source of your choosing. For example, you could obtain the information from a database, a third-party application, or a simple comma-separated file. For information on creating custom LOM manager templates, see [LOM Manager Templates, page 11-81](#).

VFrame includes a set of pre-configured LOM manager templates that can work with a variety of LOM interface types. If you use these templates, the LOM inventory macro included in the templates expects to obtain LOM interface information from an inventory file that lists each server and the LOM interface for the server. This file resides on the LOM manager that will control the server power. When you discover a LOM manager in VFrame, you are basically reading this inventory file and updating the list of servers and LOM interfaces associated with the LOM manager.

The remainder of this topic describes the inventory file that is required by the built-in LOM inventory macro.

**Tip**

The inventory file usually lists application servers only. However, you can include model servers in the inventory if you understand the potential risks. The benefit of including model servers is that VFrame will try to reboot the server after creating a golden image from the server, which restores the original operating system if the model server is not configured to PXE boot by default. The risk is that the model server will appear in the Unassociated LOMs list for the LOM manager on the Resources tab, and you might try to discover the server. If the server is configured to PXE boot by default, you might discover the server and select it for management, which would prevent you from using it as a model server.

The inventory file is a plain text file with one line for each application server and its LOM interface. You can find a sample LOM inventory file on the VFrame system by using an SSH client to log in using the **macrouser** username.

You must follow these requirements in the inventory file:

- Each server must be listed on a separate line.
- After the list of servers, you must include a line with the word **END** in all capitals. If you do not include this keyword, the LOM inventory macro will loop when executed.
- There must be a single blank line after the END line.
- You can include blank lines within the list of servers. VFrame ignores blank lines.
- You can include comments in the list of servers. Comments must begin with the # character.

Each line that represents a server has multiple attributes separated by commas. You must enter data for every field, even if you will not use the information. These are the attributes, from left to right:

- Operation—A command that instructs VFrame what to do with this record:
 - ADD_OR_UPDATE—If this LOM interface does not exist in the VFrame database, add it. If it does exist in the database, update its attributes.
 - DELETE—Remove this LOM interface from the database.

- Server MAC address—The media access control (MAC) address of the server's Ethernet NIC. For example, 00:15:60:0F:C1:D0.
- LOM IP address—The IP address of the LOM interface for the server. For example, 10.100.10.13.
- Server label—The name for the server. This name is used in VFrame when listing the server in the Servers folder on the Resource device selector. For example, server1.
- LOM label—The name for the LOM interface. This name is used in VFrame when listing the LOM interface in the details table for the LOM manager. For example, lom1.
- User attribute 1—An attribute you can use for your own purposes. The value is loaded into the LomUserAttribute1 variable, which you can process in your custom LOM macros used in a LOM template. The default LOM macros do not use this or the other user attribute variables.

Enter **none** for this or any other user attributes that you are not using.

- User attribute 2—Loaded into the LomUserAttribute2 variable.
- User attribute 3—Loaded into the LomUserAttribute3 variable.
- User attribute 4—Loaded into the LomUserAttribute4 variable.

The following is an example of an inventory file:

```
ADD_OR_UPDATE,00:16:35:5C:A0:FB,10.100.10.12,server1,lom1,none,none,none,none
ADD_OR_UPDATE,00:15:60:0F:C1:D0,10.100.10.13,server2,lom2,none,none,none,none
END
```

Configuring VFrame as a LOM Manager

You can treat the VFrame Data Center Director as the LOM manager in situations where a simple SSH or Telnet command-line utility is needed to communicate with the LOM interface on your servers. For example, you can use SSH or Telnet to communicate with HP iLO and IBM RSA2 Slimline.

During initial VFrame setup, there is an option to configure the password for the **macrouser** user account. The macrouser account is the one used as the LOM manager. If the person who set up VFrame configured this password, you can skip the first step of this procedure.

Procedure

- Step 1** Configure the password for the macrouser user account.
- Use an SSH client to log into the VFrame command line using the **admin** user name.

- Enter **config** to enter configure mode:

```
vframe# config
Enter configuration commands, one per line. End with CNTL/Z.
vframe(config)#
```

- Enter the **user password macrouser** command. You are prompted to configure the password and to verify the password:

```
vframe(config)# user password macrouser
Changing password for user macrouser.
New password: <type password>
Retype new password: <repeat password>
passwd: all authentication tokens updated successfully.
vframe(config)#
```

- Enter the **exit** command twice to leave configure mode and log out of the admin account.

- Step 2** Use an SSH client to log into VFrame using the **macrouser** account. This account provides a minimal Linux environment.

- Step 3** Create the inventory file.

The easiest way to do this is to use the **scp** command to copy an inventory file you created on another system to the VFrame system. For example, to use the **scp** command to copy the file named **inventory** from the **workspace** directory on server 10.100.20.11 using the root user login, enter:

```
[macrouser@vframe]$ scp root@10.100.20.11:/workspace/inventory .
Warning: Permanently added '10.100.20.11' (RSA) to the list of known
hosts.
root@10.100.20.11's password:
inventory                               100% 175 647.3KB/s 00:00
[macrouser@vframe]$
```

You can also use the **vi** editor to type in the LOM interface and server inventory directly or paste in the contents of another file. For more information about the inventory file, see [Creating the LOM Interface and Application Server Inventory File, page 3-24](#).

For information on using the **scp** command or the **vi** editor, see a Linux or UNIX book that covers the subject.

Step 4 Enter **exit** to log out of the macrouser account.

Step 5 Before you run LOM manager discovery, you must do the following:

- a. (Optional) Create LOM manager templates (see [Creating and Modifying LOM Manager Templates, page 11-84](#)). If the predefined templates fit your needs, you can use them instead of creating your own. You must know the CLI commands used by the LOM manager and the LOM interfaces to create templates that can be used with the LOM managers.
 - b. Define the LOM manager based on the LOM manager templates (see [Defining LOM Managers, page 11-87](#)).
 - c. Configure the LOM manager credentials in VFrame (see [Configuring Server Credentials, page 4-14](#)).
 - d. Run discovery to discover the LOM interfaces through the LOM managers (see [Discovering LOM Interfaces and the Server Inventory Through LOM Managers, page 6-13](#)).
 - e. Before you can discover the application servers defined in the LOM manager's inventory, you must configure the LOM interface credentials in VFrame (see [Configuring Server Credentials, page 4-14](#)).
-

Related Topics

- [Understanding the Expected Network Setup, page 3-1](#)
- [Servers, page 3-9](#)
- [LOM Managers, page 3-10](#)
- [Working with LOM Manager Templates, page 11-84](#)

Setting Up Independent LOM Managers

In some situations, you might need third-party client software to communicate with the LOM interfaces on servers. For example, Dell uses the `racadm` utility to communicate with DRAC. IBM uses the `smbridge` utility to communicate with BMC. In such situations, you must install the required software on an external Linux device and treat that device as the LOM manager.

For details on installing the software, see the documentation accompanying the third-party LOM manager application. The following procedure describes the high-level tasks that must also be completed.

Procedure

- Step 1 Verify that the Bash shell is installed on the LOM manager.
 - Step 2 Enable SSH.
 - Step 3 Connect the LOM manager to VFrame's management network. The LOM manager must be able to communicate with VFrame and with the LOM interface on each server.
 - Step 4 Make sure that you can make an SSH connection to the LOM manager from the VFrame Data Center Director. For information on the VFrame SSH command, see [ssh](#), page 18-78.
 - Step 5 Create the LOM interface and server inventory file that VFrame requires on the LOM manager. For more information, see [Creating the LOM Interface and Application Server Inventory File](#), page 3-24.
 - Step 6 Before you run LOM manager discovery, you must do the following:
 - a. (Optional) Create LOM manager templates (see [Creating and Modifying LOM Manager Templates](#), page 11-84). If the predefined templates fit your needs, you can use them instead of creating your own. You must know the CLI commands used by the LOM manager and the LOM interfaces to create templates that can be used to communicate with the LOM managers.
 - b. Define the LOM manager based on the LOM manager templates (see [Defining LOM Managers](#), page 11-87).
 - c. Configure the LOM manager credentials in VFrame (see [Configuring Server Credentials](#), page 4-14).
 - d. Run discovery to discover the LOM interfaces through the LOM managers (see [Discovering LOM Interfaces and the Server Inventory Through LOM Managers](#), page 6-13).
 - e. Before you can discover the application servers defined in the LOM manager's inventory, you must configure the application server LOM interface credentials in VFrame (see [Configuring Server Credentials](#), page 4-14).
-

Related Topics

- [Understanding the Expected Network Setup, page 3-1](#)
- [Servers, page 3-9](#)
- [LOM Managers, page 3-10](#)
- [Working with LOM Manager Templates, page 11-84](#)

Next Steps

[Table 3-1](#) is an overview of the steps you must take before you manage devices in VFrame.

Table 3-1 Basic Workflow for Discovering and Managing Devices

	Task
Step 1	Configure device credentials so that VFrame can communicate with the devices. Go to Configuring Device Credentials, page 4-8 .
Step 2	Configure DHCP IP address ranges so that VFrame can discover servers and create golden images. Also, configure DHCP relay agents as necessary to ensure that VFrame can respond to DHCP requests sent from PXE-booting servers. Go to Configuring DHCP for VFrame, page 5-1 .
Step 3	Run discovery to add the physical resources to the VFrame database. Go to Discovering Devices, page 6-6 .
Step 4	View the discovered physical resources in the Resources tab. Go to Understanding the Resources Tab, page 7-1 .
Step 5	From the Resources tab, select the resources that you want VFrame to manage. Go to Understanding Device Management, page 7-3 .