

CHAPTER 5

Configuring DHCP for VFrame

VFrame functions as a dynamic host configuration protocol (DHCP) server for several processes involving application and model servers. For VFrame to manage servers, you must configure DHCP settings in your Ethernet switches and in VFrame to satisfy specific requirements. The following sections describe DHCP requirements in more detail:

- [Understanding How VFrame Uses DHCP, page 5-1](#)
- [Configuring DHCP Relay Agents in Ethernet Switches, page 5-4](#)
- [Configuring DHCP in VFrame, page 5-6](#)
- [Troubleshooting DHCP, page 5-9](#)
- [DHCP Reference, page 5-9](#)

Understanding How VFrame Uses DHCP

These topics describe how VFrame acts as a DHCP server:

- [Understanding DHCP and DHCP Relay Agents, page 5-2](#)
- [Considerations for Choosing DHCP IP Address Ranges, page 5-3](#)

Understanding DHCP and DHCP Relay Agents

VFrame acts as a Dynamic Host Configuration Protocol (DHCP) server for the servers it manages. VFrame must be the only DHCP server on VFrame-managed networks to ensure correct network functioning.

VFrame acts as a DHCP server during these processes:

- Application server discovery—To discover application servers, you must PXE boot them, which sends a DHCP request to VFrame. VFrame responds with an IP address from the DHCP address table and an inventory OS. This process lets VFrame determine the physical characteristics of the server.
- Golden image creation—To create a golden image from a model server, you must PXE boot the server. VFrame provides the server an IP address from the DHCP address table and copies the model server's image during the process.
- Service network server startup—Servers assigned to a service network PXE boot when VFrame starts them. VFrame provides the server an IP address based on the IP Address Range pool assignments.

Although VFrame acts as the DHCP server for this process, VFrame does not use the addresses defined in the DHCP address table. The remainder of this topic focuses on the DHCP address table and its use. For more information on the IP Address Range pool and how its resources are used, see [Understanding Resource Pools, page 9-1](#), and [Adding IP Address Resources, page 9-11](#).

For the server discovery and golden image creation processes, you must configure a DHCP IP address range in VFrame so that VFrame can act as the DHCP server. VFrame uses IP addresses in the ranges you specify only during application server discovery and golden image creation.

VFrame can act as the DHCP server whether the PXE-booted servers are on the same subnet or VLAN or on different subnets or VLANs as VFrame. However, if VFrame is not on the same subnet or VLAN as the servers, you must configure a DHCP relay agent to forward PXE boot requests (which are DHCP requests) to the subnet or VLAN that VFrame is on. For information on configuring a DHCP relay agent, see [Configuring DHCP Relay Agents in Ethernet Switches, page 5-4](#).

VFrame configures the DHCP helper for service networks, so you do not have to manually configure DHCP helpers for your IP Address Range resource pools.

Related Topics

- [Discovering Ethernet Switches and Service Modules, page 6-6](#)
- [Discovering Servers, page 6-13](#)
- [Configuring DHCP Relay Agents in Ethernet Switches, page 5-4](#)
- [Understanding VLAN Management and the Management VLAN, page 7-5](#)

Considerations for Choosing DHCP IP Address Ranges

When deciding on the IP address ranges you will configure for DHCP, consider these factors:

- Do not include any IP addresses that are already being used, such as IP addresses configured for router interfaces, switches, model servers, VFrame's interfaces, and so forth. VFrame checks for conflicts only with the IP addresses defined on its own interfaces.
- Do not include any IP addresses that you want to use in your service networks. DHCP IP address ranges cannot overlap with IP address ranges defined in IP Address Range pools. For more information, see [Understanding Resource Pools, page 9-1](#), and [Adding IP Address Resources, page 9-11](#).
- Any IP addresses you configure for DHCP are reserved exclusively for server discovery and golden image creation. You might want to limit the number of addresses. Keep in mind that the number of addresses defined for DHCP is the maximum number of servers you can discover or create golden images from simultaneously.
- Create an address range for every subnet that includes servers you will discover or model servers you will use to create golden images. VFrame selects the address range to use based on the IP address of the router interface that forwarded the DHCP request.

Configuring DHCP Relay Agents in Ethernet Switches

If the application or model servers and VFrame are on different subnets or VLANs, you must use a DHCP relay agent to forward the DHCP requests from the servers to VFrame's server communications interface.

Figure 5-1 shows the VFrame Data Center Director and servers on different subnets.

Figure 5-1 VFrame Data Center Director and Servers on Different Subnets

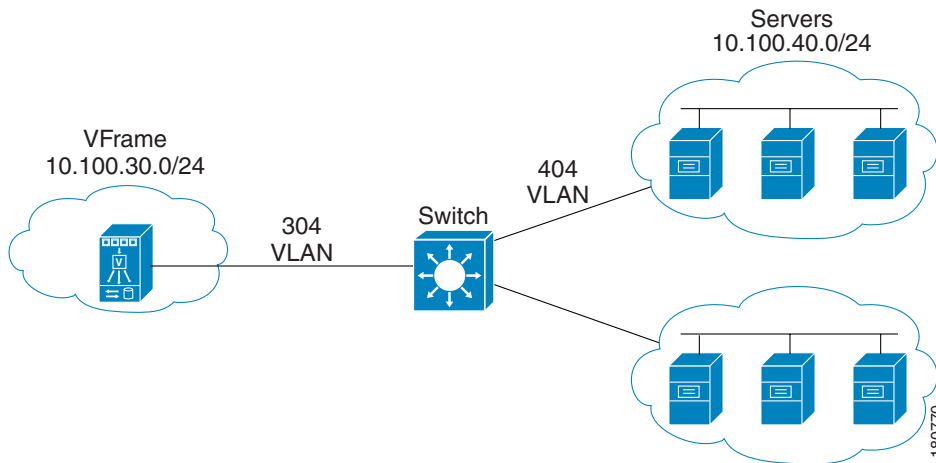

Before You Begin

Make sure that the VLAN to which VFrame's server communication interface is attached has a switched virtual interface (SVI) IP address configured.

Procedure

- Step 1** Configure the DHCP relay agent on the Ethernet switch that is connected to the servers. Log into the Ethernet switch and follow these steps:
- To enter configuration mode, enter the **configure terminal** command:

```
switch-1#configure terminal
```
 - To enter interface mode, enter the **interface vlan *vlanID*** command:

```
switch1(config)#interface vlan 404
```
 - To configure the SVI (switched virtual interface) of the VLAN if it is not already configured, enter the **ip address** command:

```
switch1(config)#ip address 10.100.40.1 255.255.255.0
```
 - To configure the DHCP relay agent, enter the **ip helper-address** command and the IP address of the VFrame server communication interface. If you are using a high-availability VFrame setup, use the VIP address of the server communication interface:

```
switch-1(config-if)#ip helper-address 10.100.30.10
```
 - To exit from interface mode, enter the **exit** command:

```
switch-1(config-if)#exit
```
 - To exit from configuration mode, enter the **exit** command:

```
switch-1(config)#exit
```
 - To verify the configuration, enter the **show run** command:

```
switch-1#show run interface vlan 404
interface Vlan404
ip address 10.100.40.1 255.255.255.0
ip helper-address 10.100.30.10
```
- Step 2** There must be a route from the subnet to the network to which VFrame's server communication interface is attached. If the router you configured as the default router during VFrame setup can route between the networks, you do not need to configure static routes. However, if the default router cannot route between the

networks, either fix the routing protocol configuration in the router, define static routes in the router, or configure static routes in VFrame. For information on configuring a static route in VFrame, see [Configuring Static Routes, page 18-8](#).

Related Topics

- [Understanding How VFrame Uses DHCP, page 5-1](#)
- [Troubleshooting DHCP, page 5-9](#)
- [Adding or Modifying DHCP IP Address Ranges, page 5-6](#)
- [Understanding VLAN Management and the Management VLAN, page 7-5](#)

Configuring DHCP in VFrame

These topics describe how to configure DHCP IP address ranges in VFrame:

- [Adding or Modifying DHCP IP Address Ranges, page 5-6](#)
- [Deleting DHCP IP Address Ranges, page 5-8](#)

Adding or Modifying DHCP IP Address Ranges

You must configure IP address ranges for VFrame to use when it responds to dynamic host configuration protocol (DHCP) requests from PXE-booting servers during server discovery or golden image creation.

Before You Begin

Determine the number of IP addresses you need to dedicate to server discovery and golden image creation, and select the IP address ranges you will define. To understand the considerations for selecting DHCP IP address ranges, see [Considerations for Choosing DHCP IP Address Ranges, page 5-3](#).

Make sure that the address ranges do not include any IP addresses statically assigned to any other device (such as a router or model server).

Procedure

- Step 1** Select **Tools > DHCP** to open the DHCP dialog box (see [DHCP Dialog Box, page 5-9](#)).
- You can also open the DHCP dialog box by clicking the **DHCP** button on the Discovery tab (select **Tools > Discovery**).
- Step 2** To add a new IP address range:
- a. Click **New** to open the DHCP Entry dialog box.
 - b. Enter the first and last IP addresses in the range you want VFrame to use when responding to PXE boot requests during server discovery or golden image creation.
 - c. Select the netmask for the address range.
 - d. Click **OK**. The address range is added to the DHCP table but it is not yet saved.
- Step 3** To modify an existing IP address range:
- a. Double-click the entry in the table, or select it and click **Edit**.
 - b. Make your changes in the DHCP Entry dialog box and click **OK**. The address range is changed but the changes are not yet saved.
- Step 4** Click **OK** in the DHCP dialog box to save your changes to the DHCP address table. Before saving the changes:
- VFrame verifies that the IP address ranges do not overlap with any address ranges defined in the IP Address Range pool, whose ranges are used by devices assigned to service networks. VFrame cannot use these addresses for server discovery or golden image creation.
 - VFrame verifies that the IP address ranges do not include any IP addresses assigned to VFrame's interfaces.

If the changes do not violate these rules, they are saved and the dialog box is closed.

Related Topics

- [Understanding DHCP and DHCP Relay Agents, page 5-2](#)
- [Configuring DHCP Relay Agents in Ethernet Switches, page 5-4](#)
- [Troubleshooting DHCP, page 5-9](#)

Deleting DHCP IP Address Ranges

If you no longer need a specific IP address range for server discovery or golden image creation, you can delete it.

Do not delete all address ranges, or VFrame cannot do any server discovery or golden image creation.

Procedure

-
- Step 1** Select **Tools > DHCP** to open the DHCP dialog box (see [DHCP Dialog Box, page 5-9](#)).
- You can also open the DHCP dialog box by clicking the **DHCP** button on the Discovery tab (select **Tools > Discovery**).
- Step 2** Select the IP address range you want to delete and click **Delete**. The range is removed from the table.
- Step 3** Click **OK** to save your changes to the DHCP address table and close the dialog box.
-

Related Topics

- [Understanding DHCP and DHCP Relay Agents, page 5-2](#)
- [Adding or Modifying DHCP IP Address Ranges, page 5-6](#)
- [Troubleshooting DHCP, page 5-9](#)

Troubleshooting DHCP

These are some problems you might encounter with resource pools and their solutions:

- [VFrame did not save the DHCP range that you just created.](#)
- [A server PXE-booted correctly, but VFrame did not respond to its DHCP request.](#)

Problem VFrame did not save the DHCP range that you just created.

Solution Adding an IP address range to the DHCP table is not enough to save the range. You must click **OK** in the DHCP dialog box to save any changes you made in the table, including additions, modifications, and deletions.

Problem A server PXE-booted correctly, but VFrame did not respond to its DHCP request.

Solution The most likely cause of this problem is that there is no DHCP relay agent configured in the Ethernet switch to forward DHCP requests from the server's subnet to VFrame's server communications interface. For information on configuring DHCP relay agents, see [Configuring DHCP Relay Agents in Ethernet Switches, page 5-4](#).

DHCP Reference

These topics describe the fields available for managing DHCP IP address ranges and reference information on using the various GUI features:

- [DHCP Dialog Box, page 5-9](#)

DHCP Dialog Box

Use the DHCP dialog box to enter the DHCP ranges for server discovery and golden image creation. VFrame provides IP addresses in these ranges to servers when they PXE boot. Create IP address ranges for each subnet on which application servers or model servers reside.

How to Get to This Dialog Box

Select **Tools > DHCP** to open the DHCP dialog box.

You can also click the **DHCP** button on the Discovery tab (select **Tools > Discovery**).

Related Topics

- [Understanding How VFrame Uses DHCP, page 5-1](#)
- [Discovering Servers, page 6-13](#)
- [Discovery Tab, page 6-21](#)

Field Reference

Table 5-1 **DHCP Dialog Box**

Element	Description
New button	Click this button to open the DHCP Entry dialog box where you can enter the start range, the end range, and the netmask. The start and end IP addresses must be in the same subnet.
Edit button	Click this button to modify the selected IP address range. This opens the DHCP Entry dialog box, where you can change any characteristic of the address range.
Delete button	Click this button to delete the selected IP address range.
Start Range	Displays the first IP address in the address range.
End Range	Displays the last IP address in the address range.
Netmask	Displays the subnet mask for the specified IP address range.
Subnet	Displays the network address of the subnet for the IP address range.
OK button	Click to save your changes to the table. Your additions, modifications, or deletions are not saved unless you click OK .