

Why Should I Care?

The evolution of the Internet to IPv6 will directly affect enterprise customers because they will have to communicate with their customers, partners, and suppliers over an IPv6 network.

In order to ensure business continuity and future growth, all organizations need to carefully plan for coexistence between IPv4 and IPv6.

Also, as IPv6 propagates, early adopters can deliver innovative platforms, applications, and services that take advantage of the technical possibilities of IPv6

A combination of both native IPv4 and IPv6, better known as dual stack, is the recommended coexistence strategy for enterprise networks

Who Needs Dual Stack Support?

- Companies that need or want to deploy IPv6 on their internal network infrastructure
- Enterprises with IPv6-enabled, employee-provided, or guest devices on their network
- Enterprises getting started with IPv6 with pilot deployment or lab trials

What Is It?

Dual stack means that devices are able to run IPv4 and IPv6 in parallel. It allows hosts to simultaneously reach IPv4 and IPv6 content, so it offers a very flexible coexistence strategy.

Benefits

- Native dual stack does not require any tunneling mechanisms on internal networks
- Both IPv4 and IPv6 run independent of each other
- Dual stack supports gradual migration of endpoints, networks, and applications

Cisco Solution for the Campus

All Layer 3 switches run dual stack:

- Dual stack (IPv4 and IPv6) from the access layer to the distribution layer, including first-hop security
- Dual stack (IPv4 and IPv6) from the distribution layer to the core layer

Solution Components

- Cisco® Catalyst® 6500, Catalyst 4500, and Catalyst 3750, 3560 and 2960 running Cisco IOS® Software

Figure 1. Dual Stack Campus

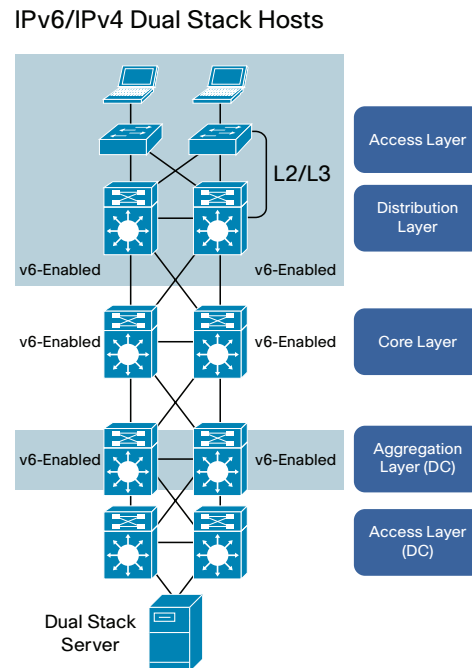

Cisco Solution for the Data Center

All Layer 3 switches run dual stack:

- Dual stack (IPv4 and IPv6) from the data center access to the aggregation layer

- Dual stack (IPv4 and IPv6) from the data center aggregation layer to the core layer
- Dual stack (IPv4 and IPv6) firewall at the data center edge

Solution Components

- Cisco Nexus® 7000, Nexus 5000, or Cisco Nexus® 2000 running Cisco NX-OS, Cisco Catalyst 4900M, or Cisco Catalyst 4948E
- Cisco ASA Adaptive Security Appliance

Figure 2. Dual Stack Data Center Network

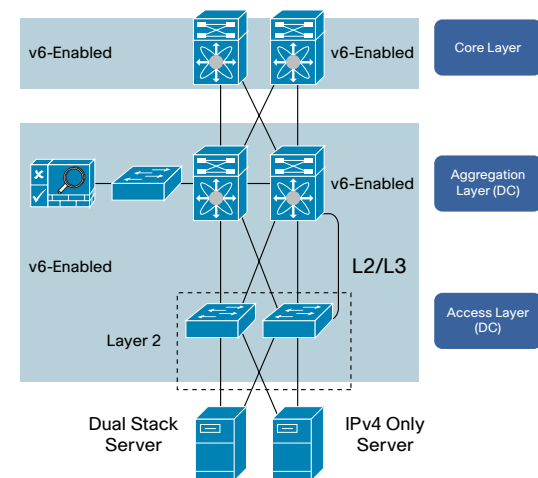

Cisco Solution for the WAN

There are two major deployment options:

- The enterprise deploys and operates its own WAN solution across a Layer 2 or Layer 3 connection provided by a service provider.
- The enterprise WAN is managed by a service provider. The customer premises equipment (CPE) could be managed or not, depending on the service.

In both cases, if the WAN network supports IPv6, then dual stack is again the recommend option.

If not, then the solution is to use tunnels to connect the IPv6 islands over IPv4. The Cisco ASR 1000 Aggregation Services Router and Cisco Integrated Services Routers Generation 2 (ISR G2) routers support a wide variety of dynamic and static tunnels that carry IPv6 over IPv4 or Multiprotocol Label Switching (MPLS) infrastructures, such as Dynamic Multipoint VPN (DMVPN), IPv6 VPN Provider Edge Router (6VPE), LISP (Locator/ID Separator Protocol) or Layer 3 VPN over multipoint generic routing encapsulation (L3VPNomGRE).

Solution Components

- Cisco ASR 1000
- Cisco ISR G2

Figure 3. Dual Stack WAN

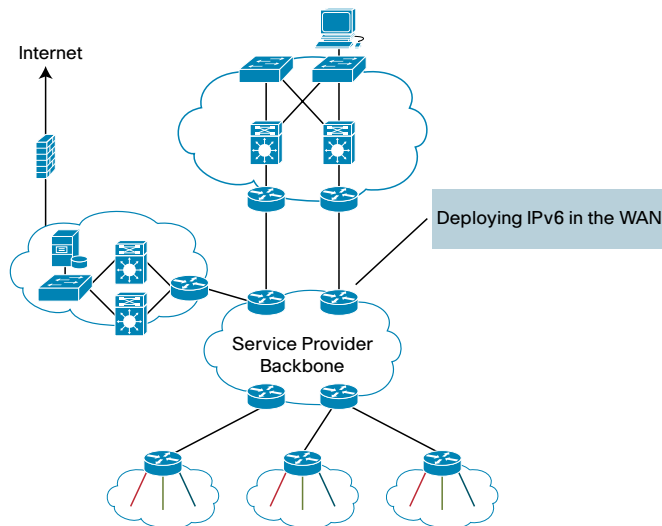

Cisco Solution for Remote Access

The Cisco AnyConnect Secure Mobility Client allows access to IPv6 resources over a public IPv4 connection.

Figure 4. Remote Access

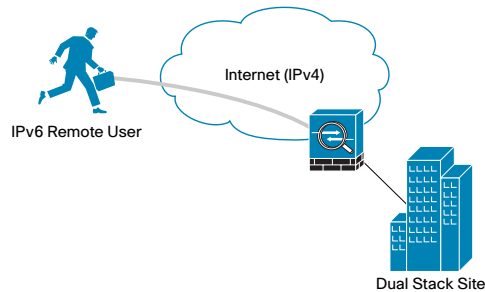

Solution Components

- Cisco ASA
- Cisco AnyConnect Secure Mobility Client

What If I Need Support for Successful IPv6 Adoption?

Cisco IPv6 Services help organizations to successfully adopt IPv6 through a phased approach in which we:

- Identify and assess the highest priority IPv6-critical areas in the network to determine IPv6 design scope.
- Develop a design that enables IPv6 to be introduced without disrupting the IPv4 network.
- Test and implement IPv6 in pilot mode, then extend over time into production deployment.
- Repeat these phases for the next IPv6-critical areas in the network through ongoing optimization.

Our proven process enables organizations to proactively budget time, money, and resources and prioritize critical areas of the network.

Cisco IPv6 Services

Whether you are integrating IPv6 into your data center, campus, WAN or remote access areas, Cisco IPv6 Services will help you to be successful.

Cisco IPv6 Discovery Service

Cisco can help you explore the potential effects to your IT infrastructure and the benefits of transitioning to IPv6.

Cisco IPv6 Assessment Service

Cisco can help you determine how your network needs to change to support IPv6 adoption through analyzing your existing Cisco network devices and assessing your network architecture to identify what will need to change to support IPv6.

Cisco IPv6 Planning and Design Service

Cisco IPv6 experts can create a network design for you based on industry-leading practices and years of IPv6 experience. This service provides designs and a transition strategy to enable introduction of IPv6 without disrupting your IPv4 network.

Cisco IPv6 Implementation Service

When you are ready to implement IPv6, Cisco can support testing to validate that your network is ready and provide implementation consulting services.

Cisco Network Optimization Service

After IPv6 has been deployed, assessment, design support, and testing of subsequent areas are handled through ongoing optimization.

Further Information

For more information about Cisco IPv6 products, solutions, and services, visit <http://www.cisco.com/go/ipv6>.