



Installing the Client Adapter

This chapter provides instructions for installing the client adapter.

The following topics are covered in this chapter:

- [Inserting a Client Adapter, page 3-2](#)
- [Installing the Client Adapter Software, page 3-9](#)
- [Installing the Intermediate Driver Manually, page 3-20](#)
- [Installing a Microsoft Hot Fix for Group Policy Delay, page 3-21](#)

Inserting a Client Adapter

This section provides instructions for inserting a PC-Cardbus card or PCI card into your computer.



Caution

These procedures and the physical connections they describe apply generally to conventional Cardbus slots and PCI expansion slots. In cases of custom or nonconventional equipment, be alert to possible differences in Cardbus slot and PCI expansion slot configurations.

Inserting a PC-Cardbus Card

- Step 1** Before you begin, examine the card. One end has a dual-row, 68-pin connector. The card is keyed so it can be inserted only one way into the Cardbus slot.



Note

The PC-Cardbus slot, if supported, is usually on the left or right side of a laptop computer, depending on the model.

- Step 2** Turn on your computer and let the operating system boot up completely.
- Step 3** Hold the card with the Cisco label facing up and insert it into the Cardbus slot, applying just enough pressure to make sure it is fully seated (see [Figure 3-1](#)). The green LED lights when the card is inserted properly.



Caution

Do not force the card into your computer's Cardbus slot. Forcing it will damage both the card and the slot. If the card does not insert easily, remove the card and reinsert it.

Figure 3-1 Inserting a PC-Cardbus Card into a Computer

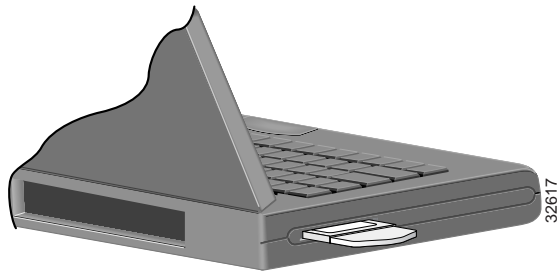

Note

The configuration profiles for PC-Cardbus cards are tied to the slot in which the card is inserted. Therefore, you must always insert your PC-Cardbus card into the same slot or create profiles for both slots. See [Chapter 4](#) for information on creating profiles for your client adapter.

Step 4 If the Found New Hardware Wizard window appears, click **Cancel**.



Note If you do not click **Cancel**, the wizard will attempt to install software for the client adapter but will be unable to find it.

Step 5 Go to the “[Installing the Client Adapter Software](#)” section on page 3-9.

Inserting a PCI Card

You must perform the following procedures in the order listed below to insert a PCI card:

- Change the bracket (if required), see below
- Insert the card, [page 3-4](#)
- Assemble the antenna, [page 3-5](#)
- Mount the antenna, [page 3-6](#)

Changing the Bracket

The PCI card is shipped with a full-profile bracket attached. If the PC into which you are inserting the PCI card requires the card to use a low-profile bracket, follow these steps to change brackets.

Step 1 Remove the two screws that attach the bracket to the card. See [Figure 3-2](#).

Figure 3-2 Changing the PCI Card Bracket

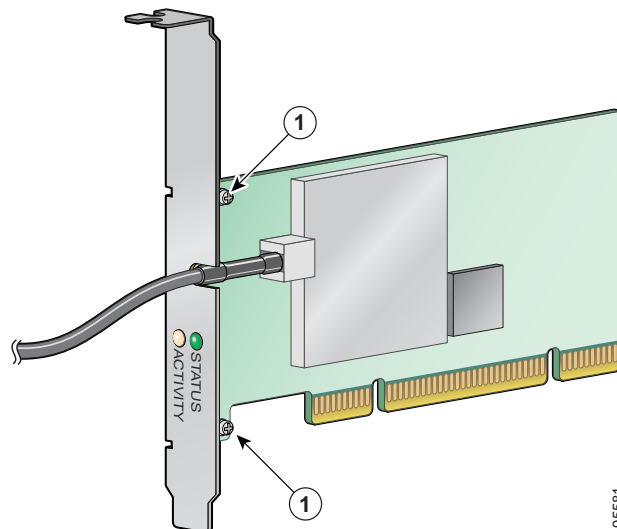

1	Bracket screws
---	----------------

Step 2 Slide the bracket away from the card; then tilt the bracket to free the antenna cable.



Caution Do not pull on the antenna cable or detach it from the PCI card. The antenna is meant to be permanently attached to the card.

Step 3 Hold the low-profile bracket to the card so that the LEDs slip through their corresponding holes on the bracket.

Step 4 Insert the screws that you removed in [Step 1](#) into the holes on the populated side of the card near the bracket (see [Figure 3-2](#)) and tighten.

Inserting the Card

Follow the steps below to insert a PCI card into your PC.

Step 1 Turn off the PC and all its components.

Step 2 Remove the computer cover.



Note On most Pentium PCs, PCI expansion slots are white. Refer to your PC documentation for slot identification.

Step 3 Remove the screw from the top of the CPU back panel above an empty PCI expansion slot. This screw holds the metal bracket on the back panel.



Caution Static electricity can damage your PCI card. Before removing the card from the anti-static packaging, discharge static by touching a metal part of a grounded PC.

Step 4 Locate an empty PCI expansion slot inside your computer.

Step 5 Slip your card's antenna through the opening near the empty expansion slot so that it is located outside of the computer. See [Figure 3-3](#).

Figure 3-3 Inserting a PCI Card into a PC

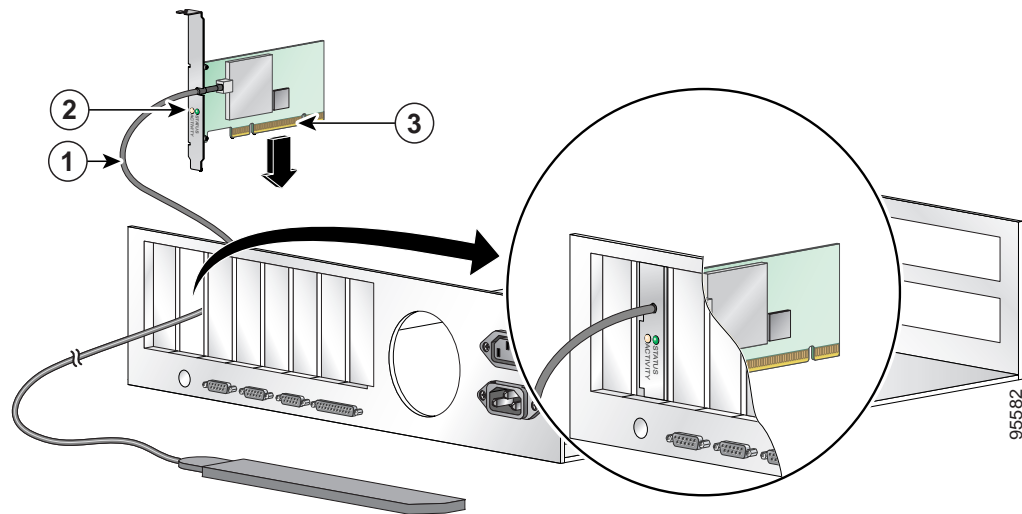

1	Antenna cable
2	LEDs
3	Card edge connector

Step 6 Tilt the card to enable the LEDs to slip through the opening in the CPU back panel. See the enlarged view in [Figure 3-3](#).

Step 7 Press the card into the empty slot until its connector is firmly seated.

**Caution**

Do not force the card into the expansion slot; this could damage both the card and the slot. If the card does not insert easily, remove it and reinsert it.

Step 8 Reinstall the screw on the CPU back panel and replace the computer cover.

Assembling the Antenna

Follow the steps below to assemble the PCI card's antenna.

Step 1 Slide the antenna through the opening in the bottom of the antenna base.

Step 2 Position the antenna so its notches are facing the Cisco label on the front of the base. See [Figure 3-4](#).

Figure 3-4 Inserting the Antenna into Its Base

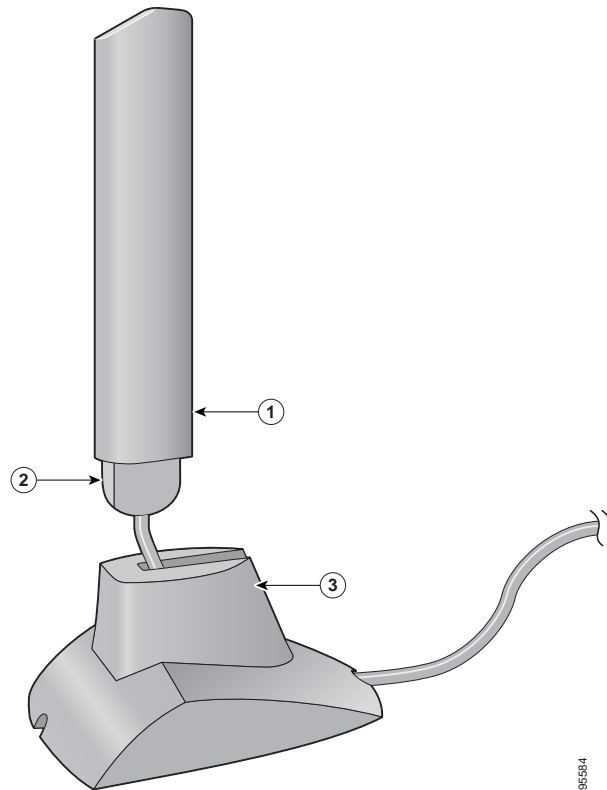

1	Antenna
2	Notch
3	Antenna base

- Step 3** Press the antenna cable into the receptacle on the top of the base as shown in [Figure 3-4](#).
- Step 4** Press the antenna straight down into the receptacle until it clicks into place.

Mounting the Antenna

Because the PCI card is a radio device, it is susceptible to RF obstructions and common sources of interference that can reduce throughput and range. Follow these guidelines to ensure the best possible performance:

- Place the PCI card's antenna in an area where large steel structures such as shelving units, bookcases, and filing cabinets will not obstruct radio signals being transmitted or received.
- Place the antenna away from microwave ovens and 2.4- and 5.8-GHz cordless phones. These products can cause signal interference because they operate in the same frequency range as the PCI card.

Follow the steps below to position the PCI card's antenna on a flat horizontal surface or to mount it to a wall.

- Step 1** Perform one of the following:
- If you want to use the antenna on a flat horizontal surface, position the antenna so it is pointing straight up. Then go to [Step 7](#).
 - If you want to mount the antenna to a wall, go to [Step 2](#).
- Step 2** Drill two holes in the wall that are 1.09 in. (2.8 cm) apart. [Figure 3-5](#) shows the distance between the mounting holes on the bottom of the antenna base.

Figure 3-5 *Bottom of Antenna Base*

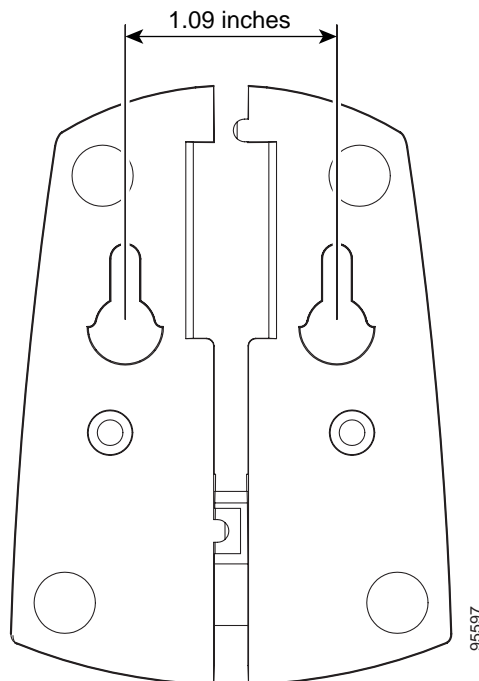

- Step 3** Tap the two supplied wall anchors into the holes.
- Step 4** Drive the two supplied screws into the wall anchors, leaving a small gap between the screw head and the anchor.
- Step 5** Position the mounting holes on the bottom of the antenna base over the screws (see [Figure 3-6](#)) and pull down to lock in place.

Figure 3-6 *Mounting the Antenna*

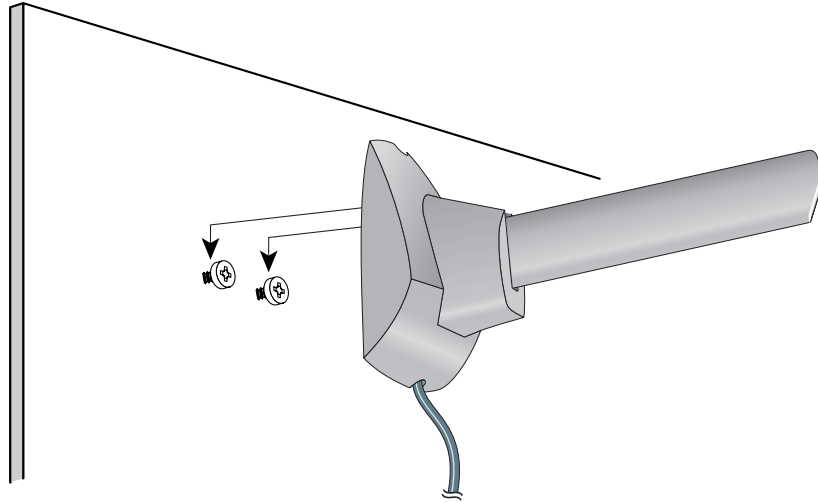

95595

- Step 6** The antenna rotates 90 degrees from its base. For optimal reception, position the antenna so it is pointing straight up (see [Figure 3-7](#)).

Figure 3-7 *Rotating the Antenna*

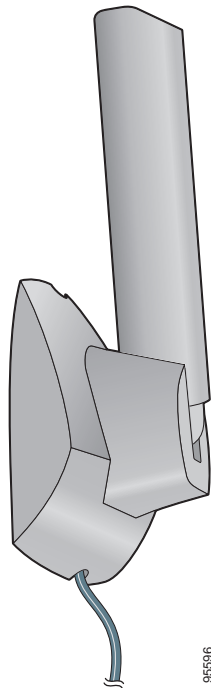

95596

- Step 7** Boot up your PC. The green LED lights when the card is inserted properly.
- Step 8** If the Found New Hardware Wizard window appears, click **Cancel**.
- Step 9** Go to the [“Installing the Client Adapter Software”](#) section below.

Installing the Client Adapter Software

This section describes how to install Cisco Aironet CB21AG or PI21AG client adapter driver and utilities from a single executable file named *WinClient-802.11a-b-g-Ins-Wizard-vx.exe*, where *x* represents the release number. Follow these steps to install these client adapter software components on a computer running Windows 2000 or XP.

**Caution**

Cisco Aironet CB21AG and PI21AG client adapter software is incompatible with other Cisco Aironet client adapter software. The Aironet Desktop Utility (ADU) must be used with CB21AG and PI21AG cards, and the Aironet Client Utility (ACU) must be used with all other Cisco Aironet client adapters.

**Caution**

Do not eject your client adapter at any time during the installation process, including during the reboot.

**Note**

This procedure is meant to be used the first time the Cisco Aironet CB21AG or PI21AG client adapter software is installed on your computer. If this software is already installed on your computer, follow the instructions in [Chapter 9](#) to upgrade the client adapter software.

**Note**

Only one CB21AG or PI21AG client adapter can be installed and used at a time. The software does not support the use of multiple CB21AG or PI21AG cards.

- Step 1** Make sure the client adapter is inserted into your computer.
- Step 2** Make sure that you have a Cisco Connection Online (CCO) username and password.
- Step 3** If you do not have a CCO username and password, go to Cisco's main page (<http://www.cisco.com>) and click Register (top). Then, follow the instructions to create a CCO username and password.
- Step 4** Browse to the following location:
<http://www.cisco.com/public/sw-center/>
- Step 5** Click **Wireless Software**.
- Step 6** Click **Wireless LAN Access**.
- Step 7** Click **Cisco Wireless LAN Client Adapters**.
- Step 8** Click **Cisco Aironet Wireless LAN Client Adapters**.
- Step 9** Perform one of the following steps:
 - If you are using a PC-Cardbus card, click **Cisco Aironet 802.11a/b/g CardBus Wireless LAN Client Adapter (CB21AG)**.
 - If you are using a PCI card, click **Cisco Aironet 802.11a/b/g PCI Wireless LAN Client Adapter (PI21AG)**.
- Step 10** When prompted, enter your CCO username and password, and click **OK**.
- Step 11** Click **Aironet Client Installation Wizard (Firmware, Driver, Utility)**.
- Step 12** Click **Windows 2000 or Windows XP**.
- Step 13** Click the link with the greatest release number.

- Step 14** Click the Install Wizard file (**WinClient-802.11a-b-g-Ins-Wizard-vxx.exe**), where **xx** is the version number.
- Step 15** If prompted, enter your CCO username and password, and click **OK**.
- Step 16** Complete the encryption authorization form, read and accept the terms and conditions of the Software License Agreement, select the file again to download it, and save the file on your computer's Desktop.
- Step 17** Use Windows Explorer to find the installer.
- Step 18** Double-click the installer. The "Starting InstallShield Wizard" message appears followed by the Preparing Setup window (see [Figure 3-8](#)) and the Cisco Aironet Installation Program window (see [Figure 3-9](#)).

Figure 3-8 Preparing Setup Window

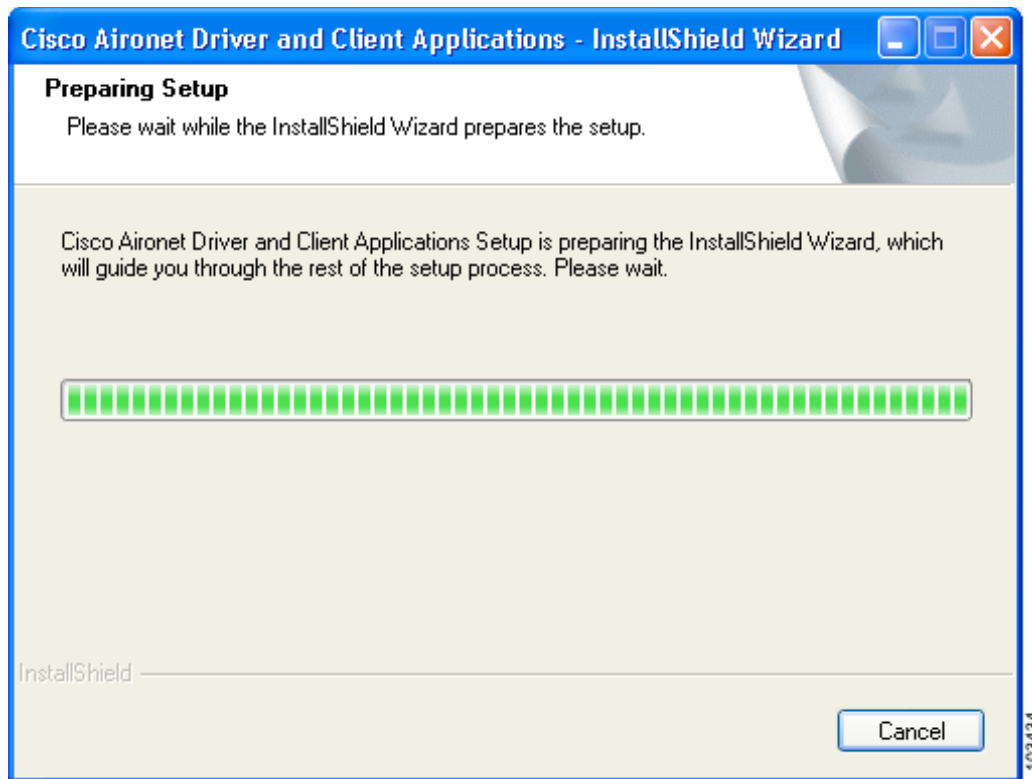
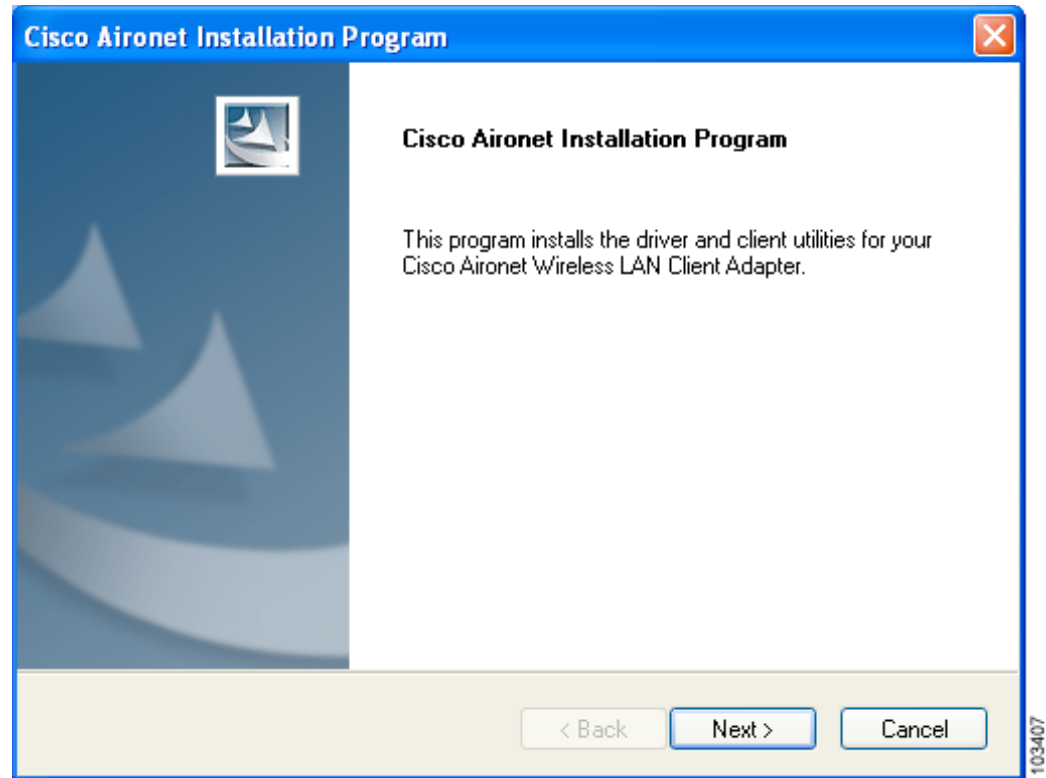
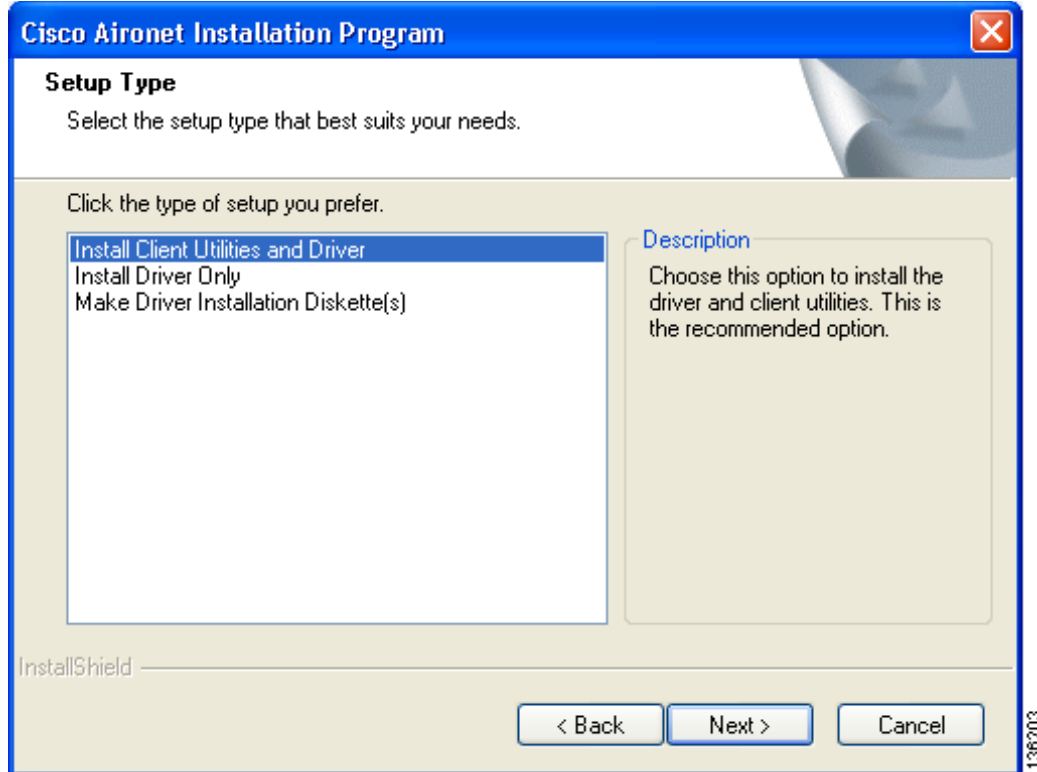

Figure 3-9 Cisco Aironet Installation Program Window



Step 19 Click **Next**. The Setup Type window appears (see [Figure 3-10](#)).

Figure 3-10 Setup Type Window



Step 20 Choose one of the following options and click **Next**:



Note To ensure compatibility among software components, Cisco recommends that you install the client utilities and driver.

- **Install Client Utilities and Driver**—Installs the client adapter driver and client utilities.
- **Install Driver Only**—Installs only the client adapter driver. If you choose this option, click **Next** and go to [Step 32](#).
- **Make Driver Installation Diskette(s)**—Enables you to create driver installation diskettes that can be used to install drivers using the Windows Device Manager.



Note If you choose one of the first two options and a client adapter is not inserted into your computer, the following message appears: “The device may not be present or could have been ejected/unplugged from the system. Insert or reinsert it now.” Insert the client adapter and click **OK**. If you proceed without the client adapter inserted, the installation continues, but the driver installation is incomplete. You must manually install the driver later using the Update Device Driver Wizard. See the “[Manually Installing or Upgrading the Client Adapter Driver](#)” section on [page 9-6](#) for instructions.

- Step 21** When the Install Cisco Aironet Site Survey Utility window appears (see [Figure 3-11](#)), check the **Install Cisco Aironet Site Survey Utility** check box if you want to install a utility that helps you to determine the best placement of infrastructure devices within your wireless network. Click **Next**.

Figure 3-11 Install Cisco Aironet Site Survey Utility Window

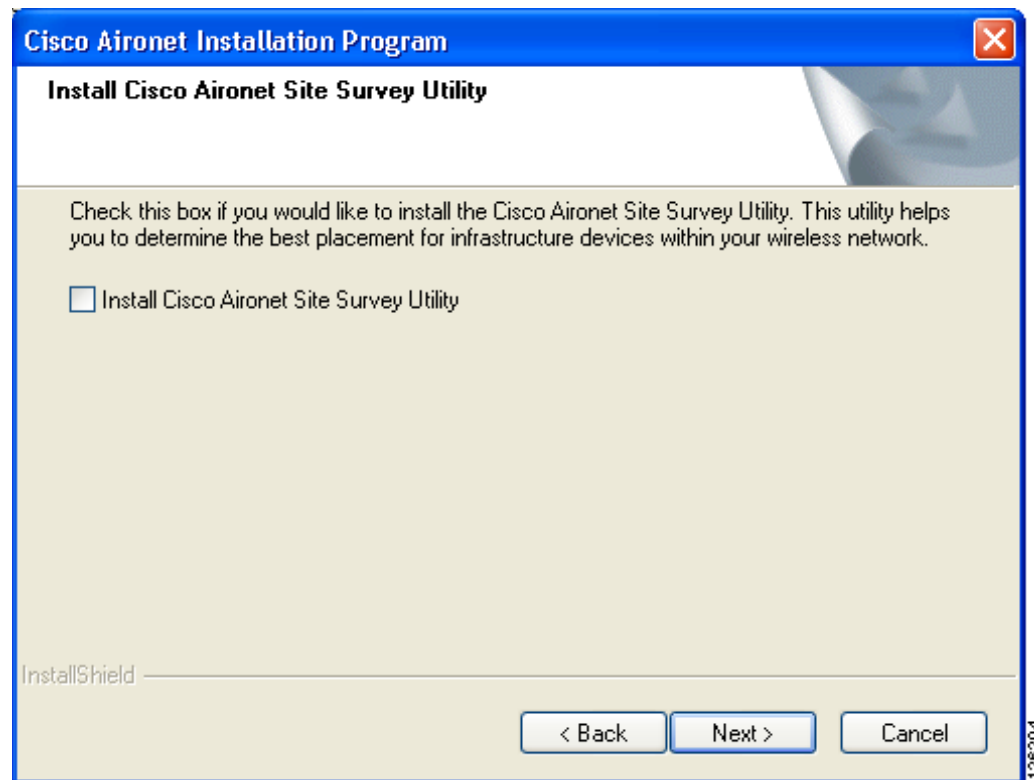

Note

The site survey utility is a stand-alone application, separate from ADU, that runs from an executable file. If you check the Install Cisco Aironet Site Survey Utility check box, the Install Wizard installs the site survey executable file in the C:\Program Files\Cisco Aironet directory (unless you specify a different directory in [Step 23](#)). See Appendix F for instructions on using the utility.

- Step 22** If a message appears indicating that you are required to restart your computer at the end of the installation process, click **Yes**.



Note

If you click **No**, you are asked to confirm your decision. If you proceed, the installation process terminates.

The Choose Destination Location window appears (see [Figure 3-12](#)).

Figure 3-12 Choose Destination Location Window

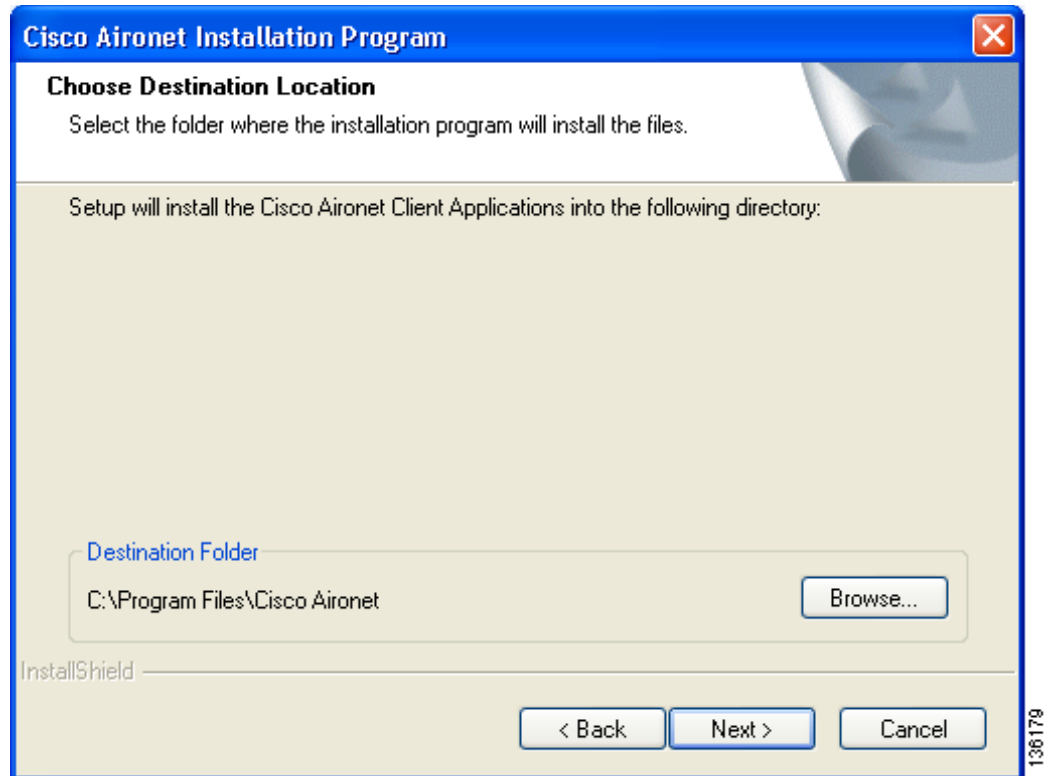

Step 23 Perform one of the following:

- If you chose the first option in [Step 20](#), click **Next** to install the client utility files in the C:\Program Files\Cisco Aironet directory.



Note If you want to install the client utilities in a different directory, click **Browse**, choose a different directory, click **OK**, and click **Next**.

- If you chose the Make Driver Installation Diskette(s) option in [Step 20](#), insert a floppy disk into your computer and click **Next** to copy the driver to the diskette. Go to [Step 32](#).



Note If you want to copy the driver to a different drive or directory, click **Browse**, choose a new location, click **OK**, and click **Next**.

Step 24 The Select Program Folder window appears (see [Figure 3-13](#)).

Figure 3-13 Select Program Folder Window

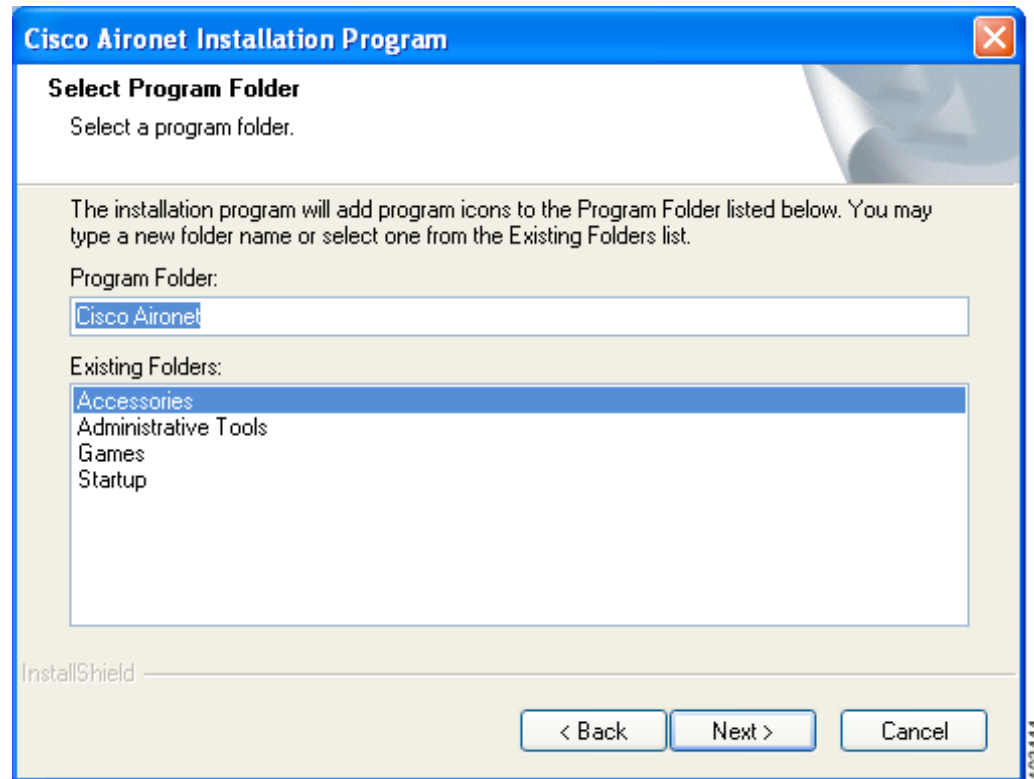

Step 25 Click **Next** to add program icons to the Cisco Aironet program folder.



Note If you want to specify a different program folder, choose a folder from the Existing Folders list or type a new folder name in the Program Folder field and click **Next**.

- Step 26** If your computer is running Windows 2000, go to [Step 32](#). If your computer is running Windows XP, the window titled **IMPORTANT: Please Read!** appears (see [Figure 3-14](#)).

Figure 3-14 *IMPORTANT: Please Read! Window*

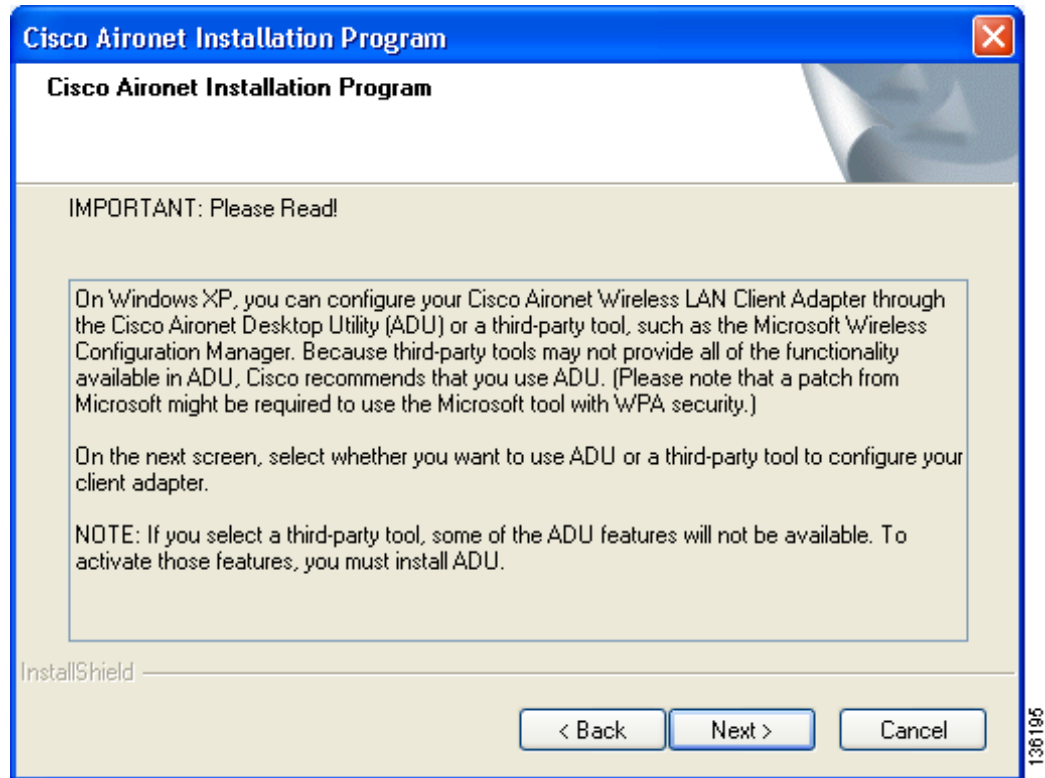

Step 27 Read the information displayed and click **Next**. The Choose Configuration Tool window appears (see [Figure 3-15](#)).

Figure 3-15 Choose Configuration Tool Window

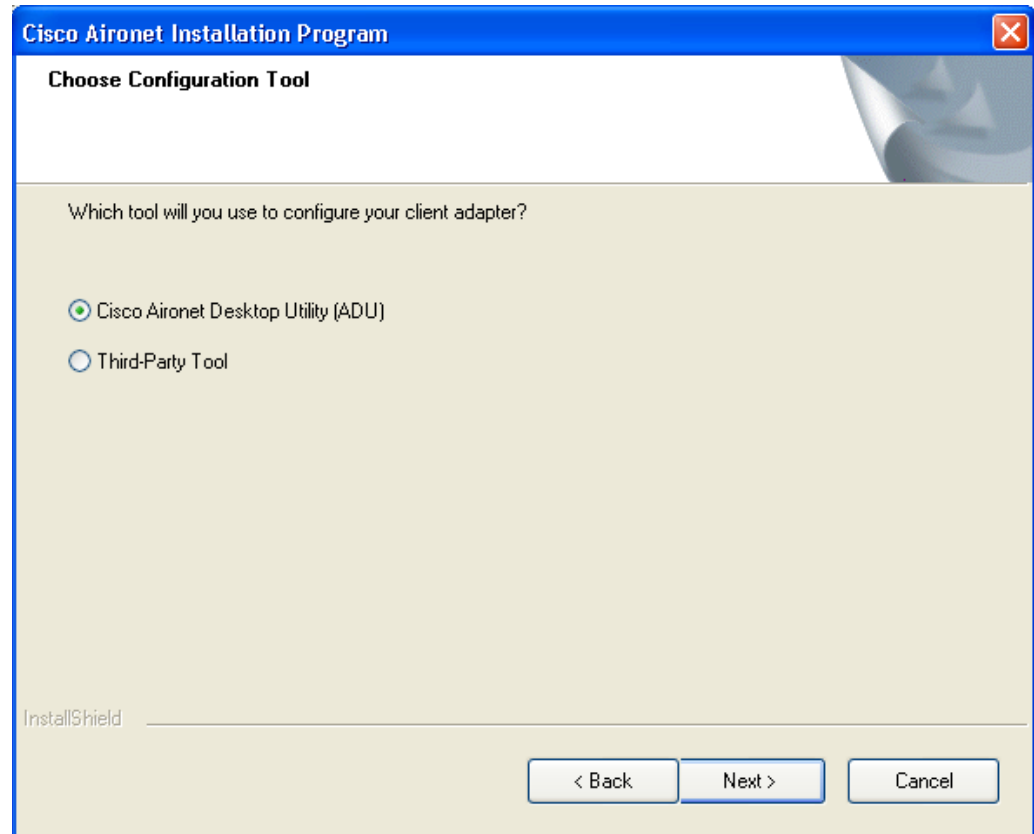

Step 28 Choose one of the following options:

- **Cisco Aironet Desktop Utility (ADU)**—Enables you to configure your client adapter using ADU.
- **Third-Party Tool**—Enables you to configure your client adapter using a third-party tool such as the Microsoft Wireless Configuration Manager in Windows XP.

[Table 3-1](#) compares Windows XP and ADU client adapter features.

Table 3-1 Comparison of Windows XP and ADU Client Adapter Features

Feature	Windows XP	ADU
Configuration parameters	Limited	Extensive
Capabilities		
Create profiles	Yes	Yes
Enable/disable radio	No	Yes

Table 3-1 Comparison of Windows XP and ADU Client Adapter Features (continued)

Feature	Windows XP	ADU
Security		
Static WEP	Yes	Yes
LEAP or EAP-FAST authentication with dynamic WEP	No	Yes
EAP-TLS or PEAP authentication	Yes	Yes
Status and statistics		
Status window	Limited	Extensive
Statistics window (transmit & receive)	No	Yes



Note If you choose Cisco Aironet Desktop Utility (ADU) above, the Microsoft Wireless Configuration Manager is disabled. If you ever manually enable it, you are prompted to disable it whenever ADU is activated.

Step 29 Click **Next**.

Step 30 If you chose Cisco Aironet Desktop Utility (ADU) in [Step 28](#), go to [Step 32](#). If you chose Third-Party Tool, the Enable Tray Icon window appears (see [Figure 3-16](#)).

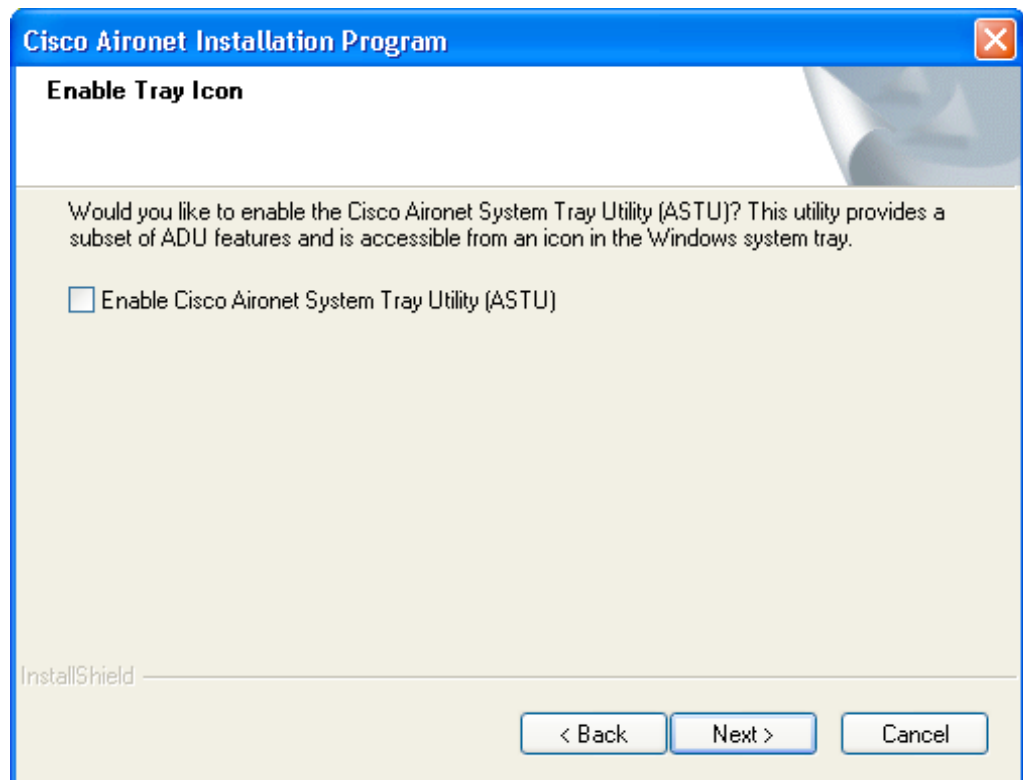
Figure 3-16 Enable Tray Icon Window

- Step 31** Check the **Enable Cisco Aironet System Tray Utility (ASTU)** check box if you want to be able to use ASTU even though you have chosen to configure your client adapter through a third-party tool instead of ADU and click **Next**.
- Step 32** When prompted to insert your client adapter, click **OK**. The Setup Status window appears (see [Figure 3-17](#)).

Figure 3-17 Setup Status Window

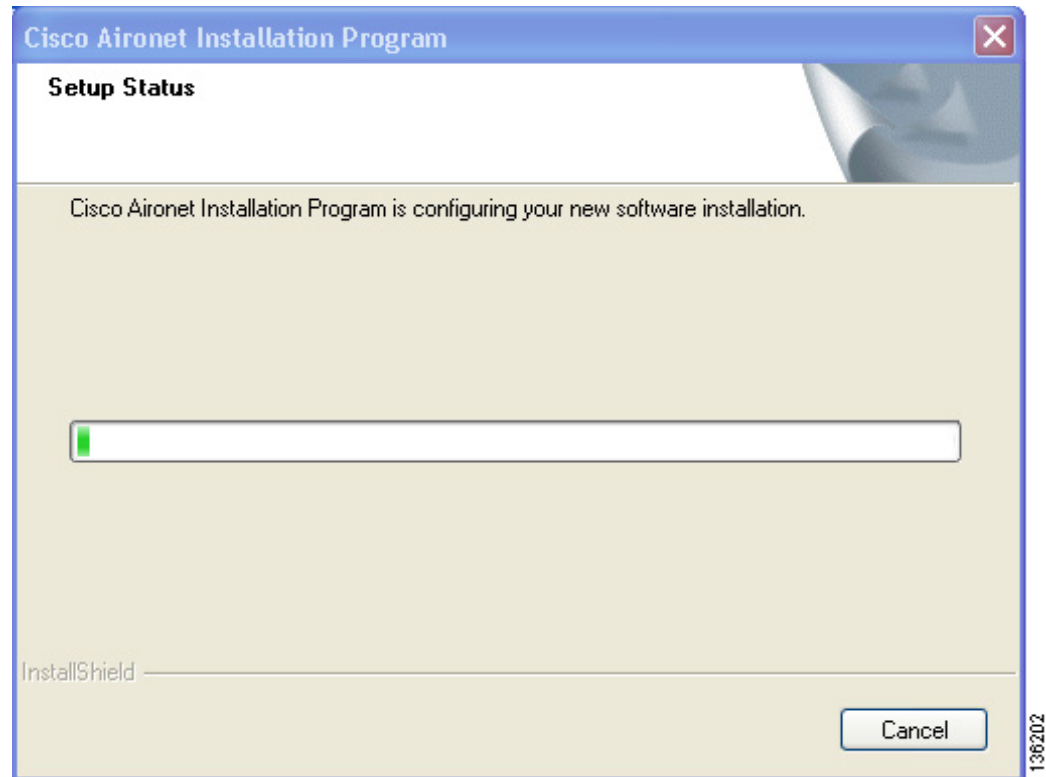

The installation process begins, and you are notified as each software component is installed.

- Step 33** When a message appears indicating that your computer needs to be rebooted, click **OK** and allow your computer to restart.
- Step 34** If the Windows Found New Hardware Wizard appears after your computer reboots, click **Next**, allow the wizard to install the software for the client adapter, and click **Finish**.
- Step 35** If your network setup does not include a DHCP server and you plan to use TCP/IP, follow these steps for your operating system.
- **Windows 2000**
 - a. Double-click **My Computer, Control Panel, and Network and Dial-up Connections**.
 - b. Right-click **Local Area Connection x** (where *x* represents the number of the connection).
 - c. Click **Properties**.
 - d. In the Components Checked Are Used by This Connection field, click **Internet Protocol (TCP/IP)** and **Properties**.

- e. Choose **Use the following IP address** and enter the IP address, subnet mask, and default gateway address of your computer (which can be obtained from your system administrator).
- f. Click **OK** to close each open window.
- **Windows XP**
 - a. Double-click **My Computer**, **Control Panel**, and **Network Connections**.
 - b. Right-click **Wireless Network Connection x** (where *x* represents the number of the connection).
 - c. Click **Properties**.
 - d. In the This Connection Uses the Following Items field, click **Internet Protocol (TCP/IP)** and **Properties**.
 - e. Choose **Use the following IP address** and enter the IP address, subnet mask, and default gateway address of your computer (which can be obtained from your system administrator).
 - f. Click **OK** to close each open window.

Step 36 If you are prompted to restart your computer, click **Yes**.

Step 37 Now that your client adapter is properly installed, it is ready to be configured.

- If you are planning to configure your client adapter through ADU, go to [Chapter 4](#) to create configuration profiles.
- If you are planning to configure your client adapter through the Windows XP Wireless Configuration Manager, go to [Appendix E](#).
- If you are planning to configure your client adapter through another third-party tool, refer to the documentation for that application.



Note

If you want to be able to use ADU's Group Policy Delay parameter, follow the instructions below to download and install a necessary hot fix before configuring your client adapter.



Note

If you experienced problems during or after installation, refer to [Chapter 10](#) for troubleshooting information.

Installing the Intermediate Driver Manually

In some instances, the installation of the CB21AG software might not work as expected because the intermediate driver might not have installed correctly. In this situation, the installer might not detect this condition, and the rest of the software will not function correctly.

The CB21AG intermediate driver must be installed manually. To install the intermediate driver manually, follow these steps:

Step 1 Insert the client adapter.

Step 2 Click on "Network Connections" in the Start > Settings menu in Windows XP, or right click on "My Network Places" in Windows 2000. Find the CB21AG instance.

- Step 3 Right click on the Cisco CB21AG instance, and left click on Properties.
 - Step 4 Choose the "Install" option and then add a new service.
 - Step 5 Choose the "Have disk" button. Go to \windows\system32 directory and choose wsimd.inf.
 - Step 6 Highlight and select "Wireless Intermediate Driver" and click "ok" button. The wireless IMD is bound to the adapter.
 - Step 7 Reboot system.
-

Installing a Microsoft Hot Fix for Group Policy Delay

If you want to use the Group Policy Delay parameter on the Profile Management (Security) window in ADU, you must install a Microsoft hot fix on computers running Windows 2000. The hot fix is incorporated into Windows XP Service Pack 2 and later.

The Group Policy Delay parameter enables you to specify how much time elapses before the Windows logon process starts Group Policy, a Windows feature used by administrators to specify configuration options for groups of users. The objective is to delay the start of Group Policy until wireless network authentication occurs. Follow the steps below to obtain and install the hot fix.

**Note**

You must be a registered Cisco customer and log into Cisco.com in order to download the hot fix. If you are unable to access the hot fix from Cisco.com, contact Microsoft Support to obtain it. The Windows 2000 support page provides the contact information:

<http://support.microsoft.com/default.aspx?scid=fh;EN-US;win2000>

- Step 1 Use your computer's web browser to access the following URL:

http://www.cisco.com/cgi-bin/tablebuild.pl/aironet_hotfix

- Step 2 If prompted, enter your Cisco Connection Online (CCO) username and password, and click **OK**.

**Note**

To create a CCO username and password, visit <http://www.cisco.com>.

- Step 3 Click the hot fix file (userenv.zip).
- Step 4 Complete the encryption authorization form and click **Submit**.
- Step 5 Click the file again to download it.
- Step 6 Save the file to your computer's hard drive.
- Step 7 Find the file using Windows Explorer, double-click it, and extract its files to a folder.
- Step 8 Reboot your computer and press **F8** while your computer is booting.
- Step 9 When the boot menu appears, select **Safe Mode with Command Prompt**.

**Note**

You must complete this procedure in safe mode; otherwise, system file protection (SFP) will silently restore the original version of the file you are replacing.

- Step 10** Copy the hot fix file (userenv.dll) to %systemroot%\System32 and overwrite the existing version of this file.
- Step 11** Delete the copy of userenv.dll in %systemroot%\System32\DllCache.
- Step 12** Reboot your computer.
-