



Troubleshooting

This chapter provides troubleshooting procedures for basic problems with the bridge. For the most up-to-date, detailed troubleshooting information, refer to the Cisco TAC website at the following URL (select **Hardware Support > Wireless Devices**):

<http://www.cisco.com/tac>

Sections in this chapter include:

- [Checking the Bridge LEDs, page 19-2](#)
- [Power Injector LEDs, page 19-4](#)
- [Checking Basic Configuration Settings, page 19-7](#)
- [Antenna Alignment, page 19-8](#)
- [Resetting to the Default Configuration, page 19-8](#)
- [Reloading the Bridge Image, page 19-9](#)

Checking the Bridge LEDs

If your bridge is not associating with the remote bridge, check the four LEDs on the back panel. You can use them to quickly assess the unit's status. For information on using the LEDs during the installation and alignment of the bridge antenna, refer to the "Bridge LEDs" section in the *Cisco Aironet 1400 Series Wireless Bridge Hardware Installation Guide*. Click this link to browse to the Hardware Installation Guide:

<http://www.cisco.com/univercd/cc/td/doc/product/wireless/aero1400/br1410/brhig/index.htm>

Figure 19-1 shows the bridge LEDs.

Figure 19-1 Bridge LEDs

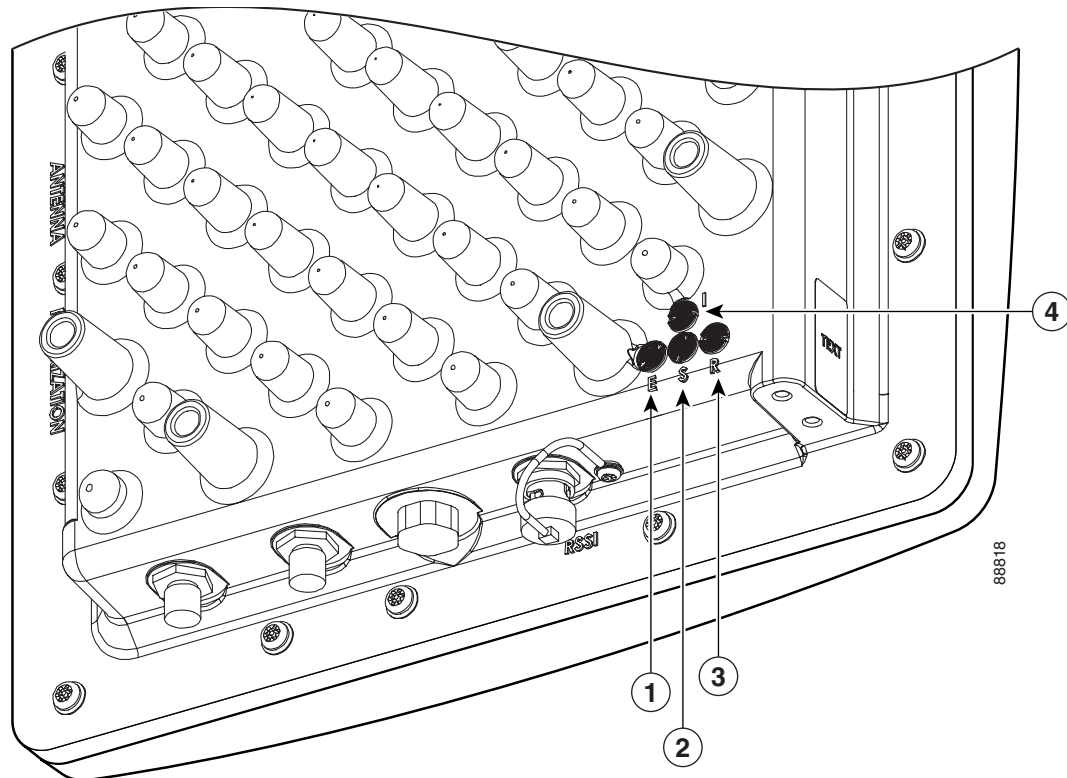

1	Ethernet LED	3	Radio LED
2	Status LED	4	Install LED

Bridge Normal Mode LED Indications

During bridge operation the LEDs provide status information as shown in [Table 19-1](#).

Table 19-1 Bridge Normal Mode LED Indications

Ethernet LED	Status LED	Radio LED	Meaning
Off	—	—	Ethernet link is down or disabled.
Green	—	—	Ethernet link is operational.
Blinking green	—	—	Transmitting and receiving Ethernet packets.
Blinking amber	—	—	Transmitting and receiving Ethernet errors.
amber	—	—	Firmware error—disconnect and reconnect the power injector power jack. If the problem continues, contact technical support for assistance.
—	Blinking green	—	Root mode—no remote bridges are associated. Non-root mode—not associated to the root bridge. If all bridges are powered up, this could be caused by incorrect SSID and security settings or improper antenna alignment. You should check the SSID and security settings of all bridges and verify antenna alignment. If the problem continues, contact technical support for assistance.
—	Green	—	Root mode—associated to at least one remote bridge. Non-root mode—associated to the root bridge. This is normal operation.
—	Blinking amber	—	General warning—disconnect and reconnect the power injector power jack. If the problem continues, contact technical support for assistance.
—	Amber	—	Loading firmware.
Red	Amber	Red	Loading Firmware error—disconnect and reconnect the power injector power. If the problem continues, contact technical support for assistance.
—	—	Off	Normal operation.
—	—	Blinking green	Transmitting and receiving radio packets—normal operation.
—	—	Blinking amber	Maximum retries or buffer full occurred on the radio interface—disconnect and reconnect the power injector power jack. If the problem continues, contact technical support for assistance.
—	—	Amber	Radio firmware error—disconnect and reconnect power injector power.If the problem continues, contact technical support for assistance.

The bridge uses a blinking code to identify various error conditions. The code sequence uses a two-digit diagnostic code that starts with a long pause to delimit the code, followed by the LED flashing red to count out the first digit, then a short pause, followed by the LED flashing red to count out the second digit (see [Table 19-2](#)).

Table 19-2 Bridge LED Blinking Error Codes

LED	Blinking Codes		Description
	First Digit	Second Digit	
Ethernet	2	1	Ethernet cable problem—verify that the cable is properly connected and not defective. This error might also indicate a problem with the Ethernet link. If the cable is connected properly and not defective, contact technical support for assistance.
Radio	1	2	Radio not detected—contact technical support for assistance.
	1	3	Radio not ready—contact technical support for assistance.
	1	4	Radio did not start—contact technical support for assistance.
	1	5	Radio failure—contact technical support for assistance.
	1	6	Radio did not flash its firmware—contact technical support for assistance.

Power Injector LEDs

The power injector contains three LEDs to provide status information on the wired Ethernet link, the bridge Ethernet link, and the bridge status. When the power injector is powered up, it sends a constant discovery tone on the dual-coax cables to the bridge. When the bridge is connected to the dual-coax cables, it returns the discovery tone to the power injector. When the power injector detects the returned discovery tone, it applies +48 VDC to the dual-coax cables to the bridge.

When power is applied to the bridge, the bridge activates the bootloader and begins the POST operations. The bridge begins to load the IOS image when the Post operations are successfully completed. Upon successfully loading the IOS image, the bridge initializes and tests the radio.

The power injector LEDs are shown in [Figure 19-2](#).

Figure 19-2 Power Injector LEDs

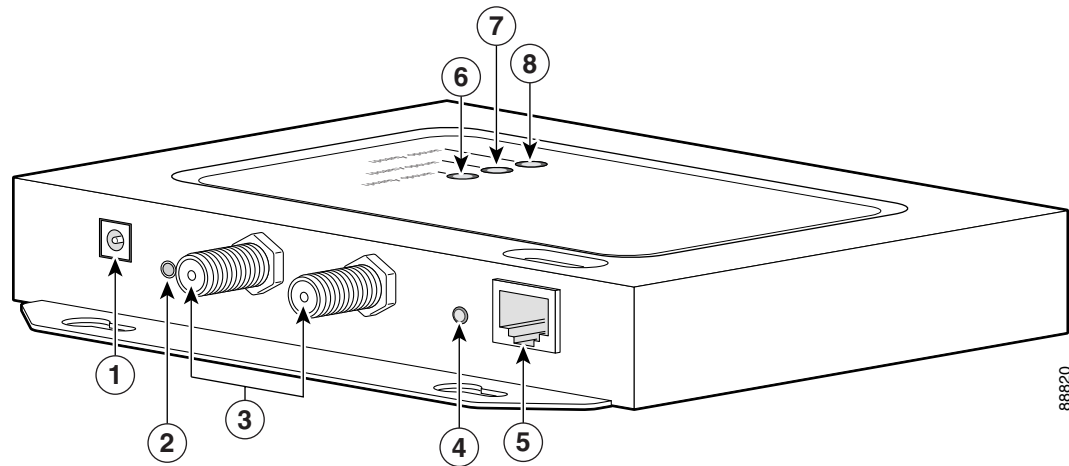

1	Power jack (+48 VDC)	5	Ethernet port (RJ-45 connector)
2	Power LED	6	Ethernet Activity LED
3	Power injector dual-coax ports (F-Type connectors)	7	Injector Status LED
4	Mode button	8	Uplink Activity LED

The power injector LED indications are shown in [Table 19-3](#).

Table 19-3 Power Injector LED Indications

Uplink Activity	Injector Status	Ethernet Activity	Description
—	—	Off	Wired LAN Ethernet link is not active.
—	—	Green	Wired LAN Ethernet link is operational.
—	—	Blinking Green	Transmitting and receiving packets over the wired LAN Ethernet link.
—	—	Amber	Power injector internal memory error—disconnect and reconnect the power injector power plug. If the problem continues, contact technical support for assistance.
Off	—	—	Link between power injector and bridge is not active. This might be caused by improper connections or a defective cable or connector. Verify that the dual-coax cables are connected correctly to the power injector, grounding block, and bridge. If the cables are connected correctly, contact technical support for assistance.
Green	—	—	Link between power injector and bridge is operational.

Table 19-3 Power Injector LED Indications (continued)

Uplink Activity	Injector Status	Ethernet Activity	Description
Blinking Green	—	—	Transmitting and receiving Ethernet packets between the power injector and the bridge.
Amber	—	—	Power injector internal memory error—disconnect and reconnect the power injector power plug. If the problem continues, contact technical support for assistance.
—	Green	—	Bridge successfully passed Power On Self Test (POST) and loaded the IOS image.
—	Blinking Green	—	Bridge power is active and the bridge is loading IOS image or POST operation has started.
—	Blinking Amber	—	Bridge has not been detected and bridge power is not active. This might be caused by bad connections or a defective cable or connector. Verify that the dual-coax cables are connected correctly to the power injector, grounding block, and bridge. If the cables are connected correctly, contact technical support for assistance.
Amber	Amber	Amber	Power injector internal memory error—disconnect and reconnect the power injector power plug. If the problem continues, contact technical support for assistance.
Off	Amber	Off	Bridge is resetting the configuration to defaults; mode button has been depressed more than 2 seconds but less than 20 seconds.
—	Red	—	Image recovery mode, downloading new image; mode button pressed more than 20 seconds.
Red	Red	Red	Power injector internal memory error—disconnect and reconnect the power injector power plug. If the problem continues, contact technical support for assistance.

Checking Power

You can verify the availability of power to the bridge by checking the power injector LEDs (see [Figure 19-2](#)):

- Power LED
 - Green color indicates 48 VDC is available to the power injector (see [Figure 19-2](#)).
 - Off indicates 48 VDC is not available to the power injector—verify that the power module is connected to the power injector and to an AC receptacle and that AC power is available.
- Uplink Activity LED
 - Green or blinking green color indicates the bridge is operating.

- Off indicates that the power injector-to-bridge link is not active—verify that the dual-coax cable connections are properly connected to the power injector, the grounding block, and the bridge. If the dual-coax cable is connected properly and the cable is not defective, contact technical support for assistance.
- Amber color indicates that an internal power injector problem—disconnect and reconnect the power injector power plug. If the problem continues, contact technical support for assistance.
- Status LED
 - Green or blinking green color indicates that the bridge is operating.
 - Blinking amber color indicates that the bridge has not been detected by the power injector and that power is not being supplied to the bridge—verify that the dual-coax cable connectors are properly connected to the power injector, the grounding block, and the bridge. If the dual-coax cable is connected properly and not defective, contact technical support for assistance.

Checking Basic Configuration Settings

Mismatched basic settings are the most common causes of lost wireless connectivity. If the bridge does not associate with a remote bridge, check the following areas.

SSID

To associate, all bridges must use the same SSID. The bridge installation mode SSID is *autoinstall* and the normal mode default SSID is *tsunami*. You should verify that the SSID value shown on the Express Setup page is the same for all bridges. You should also verify that the bridges are configured for the proper network role; only one bridge can be configured as the root bridge.

Security Settings

Remote bridges attempting to authenticate to your bridge must support the same security options configured in the bridge, such as WEP, EAP or LEAP, MAC address authentication, Message Integrity Check (MIC), WEP key hashing, and 802.1X protocol versions.

If a non-root bridge is unable to authenticate to your root bridge, verify that the security settings are the same as your bridge settings.

Antenna Alignment

If your non-root bridges are unable to associate to your root bridge, you should verify the basic configuration settings on all bridges before attempting to verify bridge antenna alignment (refer to the “[Assigning Basic Settings](#)” section on page 2-4). If your basic configuration settings are correct, you can verify antenna alignment by using the RSSI port. The RSSI port can be used even when the bridges are not associated. For additional information, refer to the “Aligning the Antenna Using the RSSI Voltage” section in the *Cisco Aironet 1400 Series Wireless Bridge Hardware Installation Guide*. Click this URL to browse to the Hardware Installation Guide:

<http://www.cisco.com/univercd/cc/td/doc/product/wireless/aero1400/br1410/brhig/index.htm>



Note

To meet regulatory restrictions, the external antenna bridge configuration and the external antenna must be professionally installed.

For detailed alignment instructions, refer to the *Cisco Aironet 1400 Series Wireless Bridge Mounting Instructions* that shipped with your bridge.

Resetting to the Default Configuration

If you forget the password that allows you to configure the bridge, you may need to completely reset the configuration. You can use the MODE button on the power injector or the web-browser interface.



Note

The following steps reset *all* configuration settings to factory defaults, including passwords, WEP keys, the IP address, and the SSID.

Using the MODE Button

Follow these steps to delete the current configuration and return all bridge settings to factory defaults using the MODE button:

- Step 1** Disconnect the power jack on the power injector.
- Step 2** Press and hold the **MODE** button while you reconnect power to the power injector.
- Step 3** Hold the **MODE** button until the Status LED turns amber (approximately 3 seconds).
- Step 4** After the bridge reboots, you must reconfigure the bridge by using the Web browser interface, the Telnet interface, or IOS commands.



Note

The bridge is configured with the factory default values including the IP address (set to receive an IP address using DHCP). To obtain the bridge’s new IP address, refer to the “[Using the IP Setup Utility](#)” section on page 2-8.

Using the Web Browser Interface

Follow the steps below to delete the current configuration and return all bridge settings to the factory defaults using the web browser interface.

- Step 1** Open your Internet browser. You must use Microsoft Internet Explorer (version 5.x or later) or Netscape Navigator (version 4.x).
- Step 2** Enter the bridge's IP address in the browser address line and press **Enter**. An Enter Network Password screen appears.
- Step 3** Enter your username in the User Name field.
- Step 4** Enter the bridge password in the Password field and press **Enter**. The Summary Status page appears.
- Step 5** Click **System Software** and the System Software screen appears.
- Step 6** Click **System Configuration** and the System Configuration screen appears.
- Step 7** Click **Default**.



Note If the bridge is configured with a static IP address, the IP address does not change.

- Step 8** After the bridge reboots, you must reconfigure the bridge by using the Web browser interface, the Telnet interface, or IOS commands.

Reloading the Bridge Image

If your bridge has a firmware failure, you must reload the complete bridge image file using the Web browser interface or by pressing and holding the MODE button for around 30 seconds. You can use the browser interface if the bridge firmware is still fully operational and you want to upgrade the firmware image. However, you can use the MODE button when the bridge has a corrupt firmware image.

Using the MODE button

You can use the MODE button on the bridge to reload the bridge image file from an active Trivial File Transfer Protocol (TFTP) server on a PC connected directly to the power injector Ethernet port.



Note If your bridge experiences a firmware failure or a corrupt firmware image, indicated by three red LEDs, you must reload the image from a directly connected PC with a TFTP server.



Note This process resets *all* configuration settings to factory defaults, including passwords, WEP keys, the bridge IP address, and SSIDs.

Follow these steps to reload the bridge image file:

-
- Step 1** The PC you intend to use must be configured with a static IP address in the range of 10.0.0.2 to 10.0.0.30.
 - Step 2** Make sure the PC contains the bridge image file (*c1410-k9w7-tar.122-13.JA.tar*) in the TFTP server folder and the TFTP server is activated. For additional information, refer to the [“Obtaining the Bridge Image File”](#) and [“Obtaining the TFTP Server Software”](#) sections.
 - Step 3** Connect the PC to the bridge using a Category 5 Ethernet cable.
 - Step 4** Disconnect the power jack from the power injector.
 - Step 5** Press and hold the **MODE** button while you reconnect power to the power injector.
 - Step 6** Hold the **MODE** button until the status LED turns red (approximately 20 to 30 seconds).
 - Step 7** Wait until the bridge reboots as indicated by all LEDs turning green followed by the Status LED blinking green.
 - Step 8** After the bridge reboots, you must reconfigure the bridge by using the Web interface, the Telnet interface, or IOS commands.

**Note**

The bridge is configured with the factory default values including the IP address (set to receive an IP address using DHCP). To obtain the bridge’s new IP address, refer to the [“Using the IP Setup Utility”](#) section on page 2-8.

Web Browser Interface

You can also use the Web browser interface to reload the bridge image file. The Web browser interface supports loading the image file using HTTP or TFTP interfaces.

**Note**

Your bridge configuration is not changed when using the browser to reload the image file.

Browser HTTP Interface

The HTTP interface enables you to browse to the bridge image file on your PC and download the image to the bridge. Follow the instructions below to use the HTTP interface:

-
- Step 1** Open your Internet browser. You must use Microsoft Internet Explorer (version 5.x or later) or Netscape Navigator (version 4.x).
 - Step 2** Enter the bridge’s IP address in the browser address line and press **Enter**. An Enter Network Password screen appears.
 - Step 3** Enter your username in the User Name field.
 - Step 4** Enter the bridge password in the Password field and press **Enter**. The Summary Status page appears.
 - Step 5** Click the **System Software** tab and then click **Software Upgrade**. The HTTP Upgrade screen appears.
 - Step 6** Click **Browse** to locate the image file on your PC.

Step 7 Click **Upload**.

For additional information, click the **Help** icon on the Software Upgrade screen.

Browser TFTP Interface

The TFTP interface enables you to use a TFTP server on a network device to load the bridge image file. Follow the instructions below to use a TFTP server:

- Step 1** Open your Internet browser. You must use Microsoft Internet Explorer (version 5.x or later) or Netscape Navigator (version 4.x).
 - Step 2** Enter the bridge's IP address in the browser address line and press **Enter**. An Enter Network Password screen appears.
 - Step 3** Enter your username in the User Name field.
 - Step 4** Enter the bridge password in the Password field and press **Enter**. The Summary Status page appears.
 - Step 5** Click **System Software** and then click **Software Upgrade**. The HTTP Upgrade screen appears.
 - Step 6** Click **TFTP Upgrade**.
 - Step 7** Enter the IP address for the TFTP server in the TFTP Server field.
 - Step 8** Enter the filename for the bridge image file (*c1410-k9w7-tar.122-13.JA.tar*) in the Upload New System Image Tar File field. If the file is located in a subdirectory of the TFTP server root directory, include the relative path of the TFTP server root directory with the filename. If the file is in the TFTP root directory, enter only the filename.
 - Step 9** Click **Upload**.
- For additional information click the **Help** icon on the Software Upgrade screen.
-

Obtaining the Bridge Image File

You can obtain the bridge image file from the Cisco.com software center by following these steps:

- Step 1** Use your web browser to go to the Cisco Software Center at the following URL:
<http://www.cisco.com/public/sw-center/sw-wireless.shtml>
- Step 2** Select **Option #1: Aironet Wireless Software Selector**.
- Step 3** For the Product Type, select **Wireless Bridge** and click **Submit**.
- Step 4** Select **1400 Series** for the model number and click **Submit**.
- Step 5** Select **Current Release (Recommended)** and click **Submit**.
- Step 6** Select **c1410-k9w7-tar.122-13.JA.tar**, which is the bridge image file.
- Step 7** On the Encryption Authorization Form, enter the requested information, read the encryption information, and check the boxes that apply. Click **Submit**.
- Step 8** Read and accept the terms and conditions of the Software License Agreement.

- Step 9** Select the bridge image file again to download it.
- Step 10** Save the file to a directory on your hard drive and then exit the Internet browser.
-

Obtaining the TFTP Server Software

You can download TFTP server software from several web sites. Cisco recommends the shareware TFTP utility available at this URL:

<http://tftpd32.jounin.net>

Follow the instructions on the website for installing and using the utility.