

Preface

This guide is designed to help you replace or upgrade your 1200 series access point's 2.4- or 5-GHz radio. Detailed installation and configuration information can be found in the *Cisco Aironet 1200 Series Access Point Hardware Installation Guide* and *Cisco Aironet 1200 Series Access Point Software Configuration Guide*, which are on Cisco.com.

Follow this link to access these documents on Cisco.com:

http://cisco.com/en/US/products/hw/wireless/ps430/tsd_products_support_series_home.html

Introduction to the 2.4- and 5-GHz Radios

The Cisco Aironet 2.4- and 5-GHz radios are designed for use in the Cisco Aironet 1200 Series Access Point. Both radios offer industry-leading range and performance and superior dual-band technology.

The 2.4-GHz radio is an IEEE 802.11b- or g-compliant 2.4-GHz radio card that is installed in the access point's mini PCI card slot. The card is located beneath an access door on the bottom of the access point.

The 2.4-GHz radio card is available in two versions:

- IEEE 802.11b mini-PCI radio card (*802.11b radio*)
- IEEE 802.11g mini-PCI radio card (*802.11g radio*)
 - Requires Cisco IOS Release 12.2(13)JA or later

The upgrade procedures are identical for both versions.

The 5-GHz radio is a IEEE 802.11a-compliant 54-Mbps 5-GHz radio module with that is inserted into the access point's cardbus slot. The cardbus slot is located on the end of the access point and is protected by an access cover when the radio module is not installed.

There are two versions of the 5-GHz radio: integrated antenna and connectorized. The integrated antenna version contains an articulated antenna paddle. The connectorized version contains two RP-TNC connectors that accept external antennas.

The 5-GHz radio module is available in three versions:

- Low power IEEE 802.11a radio module with integrated antenna (*RM20A radio module*)
- Enhanced IEEE 802.11a radio module with dual integrated antennas (*RM21A radio module*)
 - Requires Cisco IOS Release 12.3(2)JA or later.
- Enhanced IEEE 802.11a radio module with dual external RP-TNC antenna connectors (*RM22A radio module*)
 - Requires Cisco IOS Release 12.3(2)JA or later.



Tip

If you are upgrading to an 802.11g radio or an RM21A or RM22A radio module, make sure you are running the correct Cisco IOS version before you install the radio or module. If your access point is running an earlier version, it will not recognize the radio or module and continually boot.

All 5-GHz radios incorporate an Unlicensed National Information Structure (UNII) radio transceiver operating in the UNII 5-GHz frequency bands.

The upgrade procedures are identical for either version.

802.11 b/g (2.4-GHz) Radio Upgrade Instructions

This section provides a step-by-step procedure for installing or replacing an 802.11b or g 2.4-GHz radio card. The section contains the following topics:

- [“Overview” section on page 4](#)
- [“Unpacking the Radio” section on page 5](#)
- [“Opening the Access Cover” section on page 6](#)
- [“Removing the Blank Spacer Card” section on page 8](#)
- [“Removing a 2.4-GHz Radio Card” section on page 11](#)
- [“Installing a 2.4-GHz Radio Card” section on page 13](#)

Overview

The following operations summarize the 2.4-GHz radio upgrade procedure:

1. Remove all cables and power connections from the access point.
2. Follow standard electrostatic discharge (ESD) procedures.
3. Place the access point on an ESD protected work surface.
4. Open the access point’s 2.4-GHz radio access cover.

5. For an access point without the 2.4-GHz radio feature, remove the blank spacer card.
6. For an access point with the 2.4-GHz radio feature, remove the existing 2.4-GHz card.
7. Install the new 2.4-GHz radio card.
8. Close the access point 2.4-GHz radio access cover.



Caution

ESD can damage the Cisco Aironet client radio and the internal components of the access point. It is recommended that the 2.4-GHz radio upgrade procedures be performed by an ESD trained service technician at an ESD-protected workstation.

Unpacking the Radio

Each 2.4-GHz radio is shipped with the following items:

- This quick start guide
- A product registration card
- A T-10 tamper-resistant Torx L-wrench
- 2.4-GHz radio product compliance labels

If anything is missing or damaged, contact your Cisco representative for support.

Opening the Access Cover

Follow these steps to open the 2.4-GHz radio access cover:

1. Remove all cables and power connections from the access point.
2. Remove all static-generating items from the work area, such as plastic material, styrofoam cups, and other similar items.
3. Place the access point and the 2.4-GHz radio (in its anti-static bag) on a static-protected work surface.
4. Discharge any static buildup on your body by touching a grounded surface (static-protected work surface).
5. Position the access point so that its bottom cover is facing up.



Caution

The internal access point components and the 2.4-GHz radio can be damaged by ESD from improper handling.

6. Remove the bottom access cover using the provided T-10 tamper-resistant Torx L-wrench. See the illustration below.

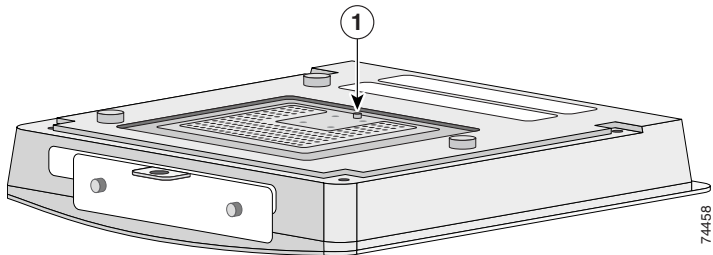

| | | | |
|----------|--------------------|--|--|
| 1 | Access Cover Screw | | |
|----------|--------------------|--|--|

If your access point was not configured with a 2.4-GHz radio, go to the next section. If you are replacing an existing 2.4-GHz radio, go to the [“Removing a 2.4-GHz Radio Card”](#) section on page 11.

Removing the Blank Spacer Card

When your access point is not factory-configured with a 2.4-GHz radio, it contains a blank spacer card in the internal mini-PCI connector. You must remove the blank spacer card prior to installing a new 2.4-GHz radio card.



Caution

Handle all components carefully and observe all ESD precautions. The internal access point components and the 2.4-GHz radio can be damaged by ESD if not handled properly.

Follow these steps to remove the blank spacer card from the mini-PCI connector. It may be helpful to refer to the following illustration before you proceed.

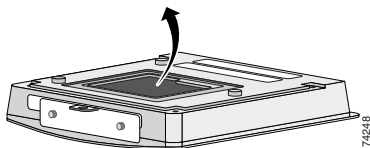
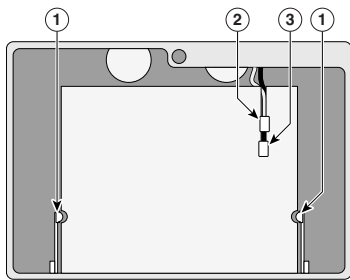

| | | | |
|----------|--------------------------------|----------|--------------------------------|
| 1 | Card-retaining clips | 3 | Antenna connector (black wire) |
| 2 | Antenna connector (white wire) | | |

1. Push the card-retaining clips (on each side of card) away from the card. When released, the card will spring up as shown in the following illustration.

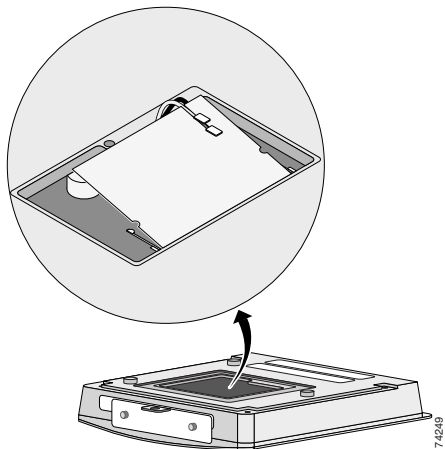

2. Carefully bend the card near the slot in opposite directions to provide enough clearance to remove the antenna wires.
3. Remove the antenna wires from the blank spacer card.



Caution

To avoid damaging the antenna wire assemblies, handle them by their connectors.

4. Remove the card from the mini-PCI connector.

For instructions on installing the radio card, go to the [“Installing a 2.4-GHz Radio Card”](#) section on page 13.

Removing a 2.4-GHz Radio Card

Follow these steps to remove a 2.4-GHz radio card from your access point.



Caution

The internal access point components and the 2.4-GHz radio can be damaged by ESD from improper handling.



Caution

The antenna connectors can be damaged if you use a pair of long-nose pliers to remove them.



Caution

To avoid damaging the antenna wire assemblies, handle them by their connectors.

1. Use your fingers to carefully remove the antenna wire connectors from the 2.4-GHz radio card.

2. Remove the 2.4-GHz radio card from the mini-PCI connector by performing the following steps:
 - a. Push the card retaining clips (on each side of the card) away from the card as shown in the following illustration. When released, the card will spring up.

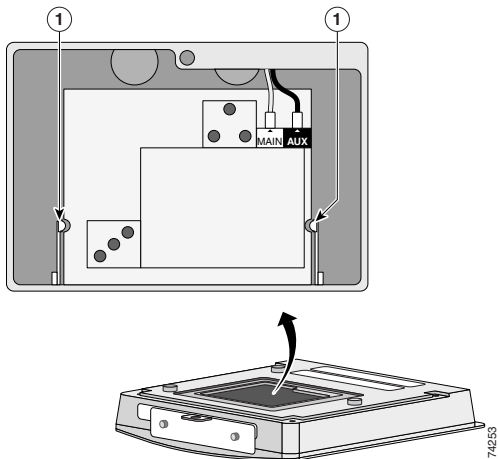

| | | | |
|---|----------------------|--|--|
| 1 | Card retaining clips | | |
|---|----------------------|--|--|

- b. Grasp the card only by its edges, being careful not to touch components on the board or the gold connector pins.
 - c. Remove the card from the mini-PCI connector.
3. Place the card into an anti-static bag.

Installing a 2.4-GHz Radio Card

Follow these steps to install a 2.4-GHz radio card in the access point.



Caution

The internal access point components and the 2.4-GHz radio can be damaged by ESD from improper handling.

1. Carefully remove the 2.4-GHz radio card from its anti-static bag.
2. Grasp the radio card only by its edges, being careful not to touch components on the board or the gold connector pins.
3. Connect the black wire's antenna connector to the radio card antenna connector marked by the black label.
4. Connect the white wire's antenna connector to the radio card antenna connector marked by the white label.

See the illustration below.

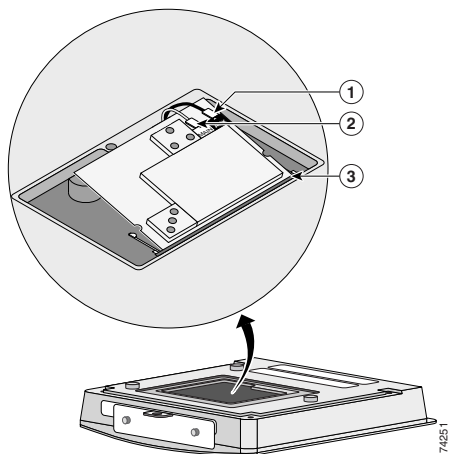

| | | | |
|----------|--------------------------------|----------|--------------------|
| 1 | Antenna connector (black wire) | 3 | Mini PCI connector |
| 2 | Antenna connector (white wire) | | |

5. Insert the radio card into the access point's mini-PCI connector by following these steps:
 - a. Tilt the radio card at approximately 20 to 30 degrees so that its gold pins are aligned with the mini-PCI connector.
 - b. Push the card into the slot until it clicks into place.
6. Carefully push the card down (towards the access point's motherboard) until the card-retaining clips lock into the notches on the side of the card (you will hear a click when the retaining clips lock into the notches).
7. Carefully position the antenna wires so that their metal connectors do not touch each other.



Caution

Damage to the radio could occur if the antenna connectors are touching. If they are, carefully rotate them in opposite directions until they are separated.

8. Make one final check of the following items:
 - a. The card is properly secured with both retaining clips engaged.
 - b. The antenna connectors are not touching.
9. Reinstall the 2.4-GHz radio access cover and use the T-10 tamper-resistant Torx L-wrench to tighten the cover's retaining screw.

10. Remove the backing paper from the 2.4-GHz radio product compliance label.
11. Carefully attach the label in the space provided below the access point's product compliance label as shown in the following illustration.

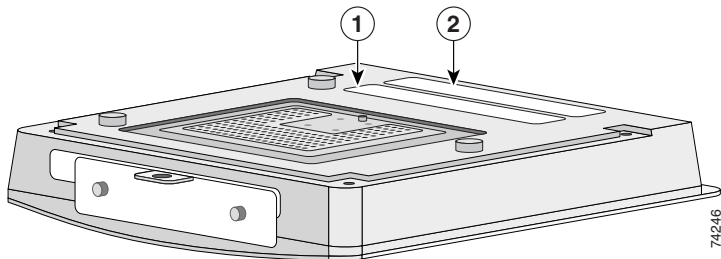

| | | | |
|----------|--|----------|---------------------------------------|
| 1 | 2.4-GHz radio product compliance label | 2 | Access point product compliance label |
|----------|--|----------|---------------------------------------|



Note

If your access point contains a 5-GHz radio module, there will also be a 5-GHz radio product compliance label on the back of the access point.

802.11a (5-GHz) Radio Upgrade Instructions

This section provides a step-by-step procedure for installing or replacing an 802.11a, 5-GHz radio module. The section contains the following topics:

- [“Overview” section on page 17](#)
- [“Unpacking the Radio Module” section on page 18](#)
- [“Removing the 5-GHz Radio Access Cover” section on page 18](#)
- [“Removing a 5-GHz Radio Module” section on page 20](#)
- [“Installing a 5-GHz Radio Module” section on page 22](#)

Overview

The following operations summarize the 5-GHz radio upgrade procedure:

1. Remove all cables and power connections from the access point.
2. For an access point without the 5-GHz radio feature, remove the access cover.
3. For an access point with the 5-GHz radio feature, install the new 5-GHz radio module.

Unpacking the Radio Module

Each 5-GHz radio module is shipped with the following items:

- This quick start guide
- A product registration card
- A T-10 tamper-resistant Torx L-wrench
- A 5-GHz radio product compliance label

If anything is missing or damaged, contact your Cisco representative for support.



Caution

Handle all components carefully and observe all ESD precautions. The internal access point components and the 5-GHz radio can be damaged by ESD if not handled properly.

Removing the 5-GHz Radio Access Cover

If your access point was configured with a 5-GHz radio, go to the [“Removing the 5-GHz Radio Access Cover” section on page 18](#). If your access point was not configured with a 5-GHz radio, follow the steps below to remove the 5-GHz radio access cover:

1. Remove all cables and power connections from the access point.

2. Place the access point on a flat surface so that it is upright with the front end facing you.
3. Remove the 5-GHz radio access cover using the supplied T-10 tamper-resistant Torx L-wrench. See the following illustration.

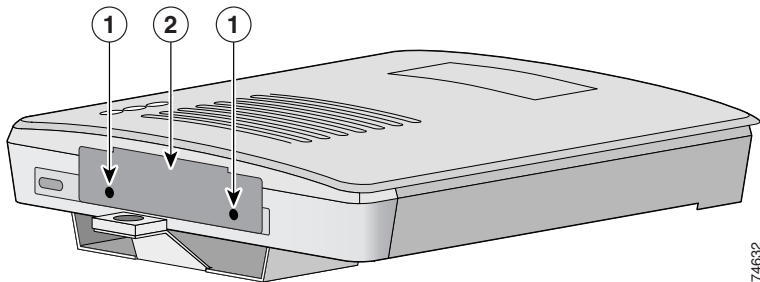

74632

| | | | |
|----------|---------------------|----------|--------------|
| 1 | Access cover screws | 2 | Access cover |
|----------|---------------------|----------|--------------|



Note

The following procedure use the integrated antenna radio module to illustrate the removal and installation process. The procedure is identical for the connectorized radio module.

Removing a 5-GHz Radio Module

When your access point is configured with a 5-GHz radio module, follow these steps to remove it:

1. Remove all cables and power connections from the access point. If you are removing the connectorized antenna version, remove the antenna cables from the radio module.
2. Place the access point on a flat surface so that it is upright with the front end facing you.
3. Unscrew the two mounting screws using the supplied T-10 tamper-resistant Torx L-wrench. See the following illustration.

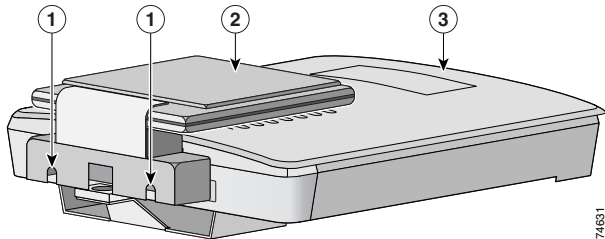

| | | | |
|----------|----------------------------|----------|--------------|
| 1 | Mounting screws | 3 | Access point |
| 2 | 5-GHz radio module antenna | | |

**Note**

Do not attempt to remove the mounting screws from the module; they are captured in the module's housing.

4. Insert your fingers into the base of the 5-GHz radio module (closest to the access point) and pull straight out from the access point. See the following illustration.

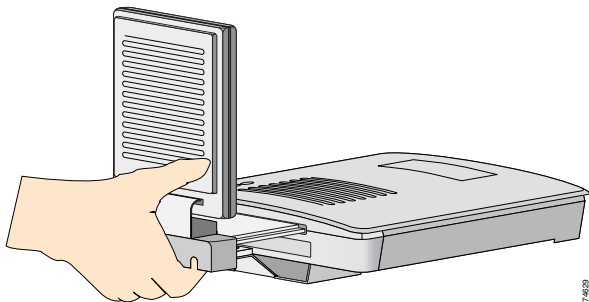

5. Fold the antenna down and insert the module into a static protected bag.

Installing a 5-GHz Radio Module



Caution

Before installing a 5-GHz radio module, verify that the access point is running the proper firmware. The RM20A radio module is VxWorks-based and must be running version 11.54T or later. The RM21A and RM22A is Cisco IOS-based and must be running 12.3(2)JA or later. If your access point is running earlier firmware versions, it will not recognize the 5-GHz radio.

Follow these steps to install a 5-GHz radio module in your access point.

1. Make sure the module access cover on the access point is removed.
2. Place the access point on a flat surface so that it is upright with its front end facing you.
3. Grasp the new 5-GHz module by its base with the antenna pointing up, and insert the card into the access point card bus slot. The following illustration shows the integrated antenna version.

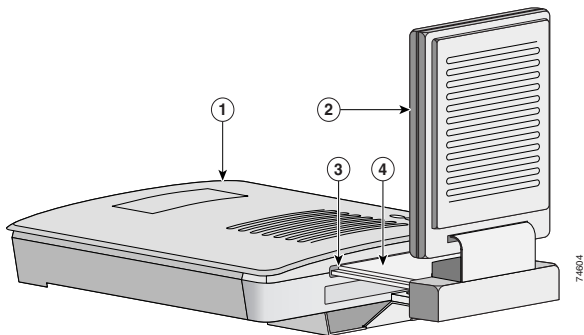

| | | | |
|----------|----------------------------|----------|----------------------------|
| 1 | Access point | 3 | Access point card bus slot |
| 2 | 5-GHz radio module antenna | 4 | 5-GHz radio card |

The next illustration shows the connectorized antenna version.

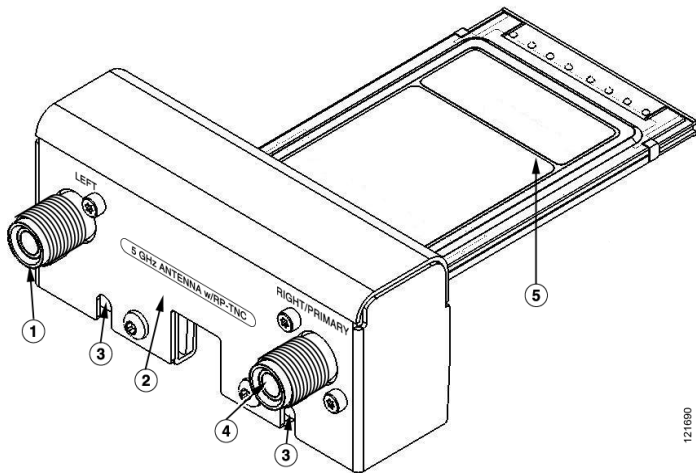

121890

| | | | |
|---|-------------------------------|---|--|
| 1 | Left RP-TNC antenna connector | 4 | Right/Primary RP-TNC antenna connector |
| 2 | 5-GHz RP-TNC label | 5 | 5-GHz radio card |
| 3 | Module mounting screws | | |

4. Carefully push the 5-GHz radio module into the slot until it stops.
5. Turn the access point upside down and make sure the two captive mounting screws are aligned with their respective holes. If they are not, use your fingers to line them up.



Caution

The captured mounting screws may skew sideways, which could damage the module if it is forced into the cardbus.

6. After making sure that the screws are started into their holes, push the module the rest of the way into the cardbus until it is seated.
7. Use the T-10 tamper-resistant T-10 Torx L-wrench to tighten the module's captured mounting screws. See the following illustration.

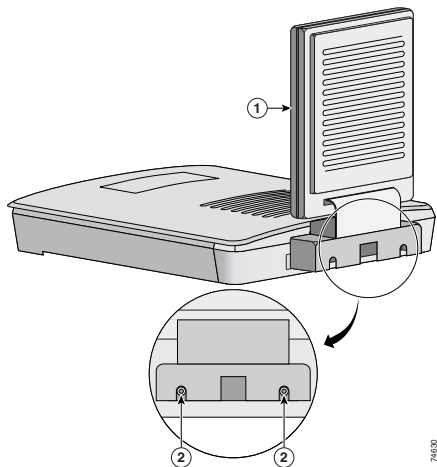

74630

| | | | |
|----------|----------------------------|----------|-----------------|
| 1 | 5-GHz radio module antenna | 2 | Mounting screws |
|----------|----------------------------|----------|-----------------|

8. Remove the backing paper from the 5-GHz radio product compliance label.
9. Carefully attach the label in the space provided below the access point product compliance labels.



Note

If your access point contains an internal 2.4-GHz radio card, a 2.4-GHz radio product compliance card should be attached to the access point.

10. Remount the access point.
11. Install the antenna or external antenna cable (connectorized version only). If you are installing one antenna, connect it to the connector marked *Right/Primary* as shown in this illustration.

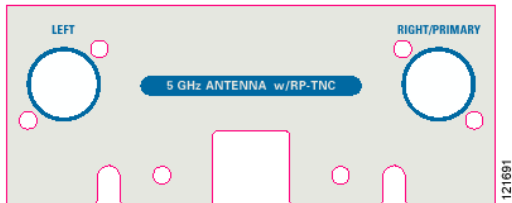

Note

5-GHz antennas must be installed. Cisco-approved 5-GHz antennas are identified by a blue dot on the antenna near the connector or a blue band on the antenna cable near the connector.

This illustration shows the connectorized version with external antennas installed.

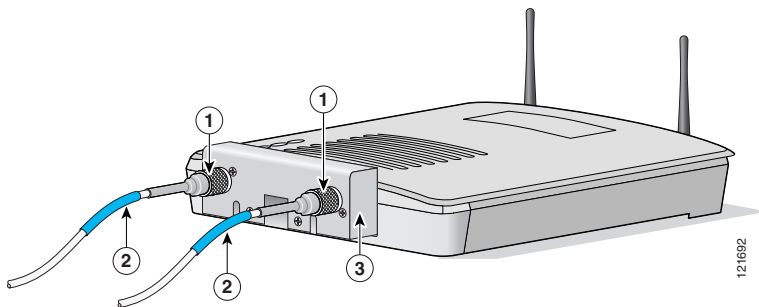

121692

| | | | |
|----------|--------------------------------|----------|--------------------|
| 1 | RP-TNC antenna connector | 3 | 5-GHz radio module |
| 2 | 5-GHz antenna identifier label | | |

Configuring the Radios

After you have installed either radio in the access point, you must configure the radio to operate in your wireless network.

**Note**

If you are located outside the United States, you must adjust the transmit output power to conform with the levels established by the regulations for the country in which the access point operates. See the *Cisco Aironet 1200 Series Access Point Software Configuration Guide* for instructions.

Basic configuration instructions can be found in the *Quick Start Guide Cisco Aironet 1200 Series Access Point Running Cisco IOS Operating System*, which is shipped with the access point.

Detailed configuration instructions can be found in the *Cisco Aironet 1200 Series Access Point Hardware Installation Guide* or the *Cisco Aironet 1200 Series Access Point Software Configuration Guide*. These guides are available at Cisco.com. Follow this link to access these documents:

http://cisco.com/en/US/products/hw/wireless/ps430/tsd_products_support_series_home.html

In Case of Difficulty

If you followed the instructions in previous sections of this guide, you should have had no trouble getting your access point installed and running. However, if you did experience difficulty, help is available from Cisco. Before contacting Cisco, look for a solution to your problem in the following places:

- The troubleshooting section of the *Cisco Aironet 1200 Series Access Point Hardware Installation Guide* or the *Cisco Aironet 1200 Series Access Point Software Configuration Guide*
- The Technical Support section at Cisco.com

Follow this link access Cisco's Technical Support section:

<http://cisco.com/en/US/support/index.html>

Safety Information

The FCC with its action in ET Docket 96-8 has adopted a safety standard for human exposure to radio frequency (RF) electromagnetic energy emitted by FCC certified equipment. When used with approved Cisco Aironet antennas, Cisco Aironet products meet the uncontrolled environmental limits found in OET-65 and ANSI C95.1, 1991. Proper installation of this radio according to the instructions found in this manual and the *Cisco Aironet 1200 Series Access Point Hardware Installation Guide* will result in user exposure that is substantially below the FCC recommended limits.

- Do not touch or move antenna(s) while the unit is transmitting or receiving.
- Do not hold any component containing a radio such that the antenna is very close to or touching any exposed parts of the body, especially the face and eyes, while transmitting.

- Do not operate the radio or attempt to transmit data unless the antenna is connected; otherwise the radio may be damaged.
- Antenna use:
 - High-gain, wall-mount, or mast-mount antennas are designed to be professionally installed. Cisco recommends that you contact your professional installer, VAR, or antenna manufacturer to obtain proper installation requirements.



Warning

Do not operate a portable transmitter near unshielded blasting caps or in an explosive environment unless it is a type especially qualified for such use.



Warning

In order to comply with FCC RF exposure limits, antennas should be located at a minimum of 7.9 in. (20 cm) from the body of all persons.

Compliance Information

This equipment has been tested and found to comply with the European Telecommunications Standard ETS 300.328 (2.4-GHz version) and ETS 301.893 (5-GHz version). This standard covers Wideband Data Transmission Systems referred to in CEPT recommendation T/R 10.01.

This type-accepted equipment is designed to provide reasonable protection against harmful interference when the equipment is operated in a commercial environment. This equipment generates, uses, and can radiate radio frequency energy and, if not installed in accordance with the instruction manual, may cause harmful interference to radio communications.

Cisco One-Year Limited Hardware Warranty Terms

There are special terms applicable to your hardware warranty and various services that you can use during the warranty period. Your formal Warranty Statement, including the warranties and license agreements applicable to Cisco software, is available on Cisco.com. Follow these steps to access and download the *Cisco Information Packet* and your warranty and license agreements from Cisco.com.

1. Launch your browser, and go to this URL:
http://www.cisco.com/univercd/cc/td/doc/es_inpkc/cetrans.htm

The Warranties and License Agreements page appears.

2. To read the *Cisco Information Packet*, follow these steps:
 - a. Click the **Information Packet Number** field, and make sure that the part number 78-5235-03A0 is highlighted.
 - b. Select the language in which you would like to read the document.
 - c. Click **Go**.

The Cisco Limited Warranty and Software License page from the Information Packet appears.

- d. Read the document online, or click the **PDF** icon to download and print the document in Adobe Portable Document Format (PDF).



Note

You must have Adobe Acrobat Reader to view and print PDF files. You can download the reader from Adobe's website: <http://www.adobe.com>.

3. To read translated and localized warranty information about your product, follow these steps:
 - a. Enter this part number in the Warranty Document Number field:

78-10747-01C0

- b. Select the language in which you would like to view the document.
- c. Click **Go**.

The Cisco warranty page appears.

- d. Read the document online, or click the **PDF** icon to download and print the document in Adobe Portable Document Format (PDF).

You can also contact the Cisco service and support website for assistance:

http://www.cisco.com/public/Support_root.shtml.

Duration of Hardware Warranty

One (1) Year

Replacement, Repair, or Refund Policy for Hardware

Cisco or its service center will use commercially reasonable efforts to ship a replacement part within ten (10) working days after receipt of a Return Materials Authorization (RMA) request. Actual delivery times can vary, depending on the customer location.

Cisco reserves the right to refund the purchase price as its exclusive warranty remedy.

To Receive a Return Materials Authorization (RMA) Number

Contact the company from whom you purchased the product. If you purchased the product directly from Cisco, contact your Cisco Sales and Service Representative.

Complete the information below, and keep it for reference.

| | |
|--------------------------------|--|
| Company product purchased from | |
| Company telephone number | |
| Product model number | |
| Product serial number | |
| Maintenance contract number | |

