

# Read This First

Recent Cisco IOS releases have changed the way an unconfigured access point behaves when booted for the first time. This section describes this behavior and provides instructions on how to open the access point's configuration pages.

## Cisco IOS Release 12.2(15)JA and Earlier

Setting	Default	Remarks
Login/Password	Cisco/Cisco	Case-sensitive
SSID	tsunami	—
Radio status	Enabled	—
IP Address	Assigned by DHCP	If DHCP disabled, the default IP address is 10.0.0.1. See the “Configuring the Access Point” section on page 25 for additional information.

## Cisco IOS Release 12.3(2)JA

Setting	Default	Remarks
Login/Password	Cisco/Cisco	Case-sensitive
SSID	tsunami	Case-sensitive
Radio status	Enabled	—
IP Address	Assigned by DHCP	If DHCP disabled, the access point continues to send DHCP requests indefinitely. To assign an IP address, you must access the unit's console port. See the "Assigning an IP Address Using the CLI" section on page 33 for additional information.

## Cisco IOS Release 12.3(4)JA and Later

Setting	Default	Remarks
Login/Password	Cisco/Cisco	Case-sensitive
SSID	None assigned	You must create an SSID. See the “Assigning an IP Address Using the CLI” section on page 33
Radio status	disabled	You must enable the radio interfaces. “Enabling the Radio Interfaces” section on page 4 for additional information.
IP Address	Assigned by DHCP	If DHCP disabled, the access point continues to send DHCP requests indefinitely. To assign an IP address, you must access the unit’s console port. See the “Assigning an IP Address Using the CLI” section on page 33 for additional information.

# Enabling the Radio Interfaces

In Cisco IOS Release 12.3(4)JA and later, the access point radios are disabled by default, and there is no SSID. You must create an SSID and enable the radios before the access point will allow wireless associations from other devices. These changes to the default configuration improve the security of newly installed access points.

To enable the radio interfaces using the access point's graphical user interface (GUI), follow these instructions:

1. Use your internet browser to access your access point. The default login and password is *Cisco*. Both are case-sensitive.
2. When the Summary Status page displays, click **Express > SSID Manager**. The Global SSID Manager page appears.
3. Create an SSID for each radio interface. An SSID can be any alphanumeric, case-sensitive entry from 2 to 32 characters. The following six characters are not allowed: ?, ", \$, [ , \, and +. In addition, the following three characters cannot be the first character: !, #, and ;.
4. Click **Apply**.
5. Click **Network Interfaces > Radio 802.11b** or **Network Interfaces > Radio 802.11g** and the Radio Status page appears.
6. Click **Settings** and the Radio Settings Page appears.
7. Click **Enable** in the Enable Radio field.

8. Click **Apply**.
9. Click **Radio1-802.11A** and the Radio Status page appears.
10. Repeat Steps 3 to 5.
11. Close your internet browser.



---

**Note**

You can enable the radios using the access point's Command Line Interface (CLI). See the *Cisco IOS Software Configuration Guide for Cisco Aironet Access Points* for additional information.

---

## Preface

This guide is designed to help you install and minimally configure your IOS-based Cisco Aironet 1200 Series Access Point in a wireless Local Area Network (LAN). Detailed installation and configuration information can be found in the following documents:

- *Cisco IOS Software Configuration Guide for Cisco Aironet Access Points*
- *Aironet 1200 Series Access Point Installation and Configuration Guide*
- *Cisco IOS Command Reference for Cisco Aironet Access Points and Bridges*

These documents are on Cisco.com. Another document, *Radio Upgrade Instructions: Cisco Aironet 1200 Series Access Points*, is shipped with radio upgrade kits for 2.4- and 5-GHz radios.

Follow these steps to access these documents:

1. Browse to <http://www.cisco.com>.
2. Click **Technical Support and Documentation**. Click it again in the pop-up window that appears. The Technical Support and Documentation page appears.
3. Click **Wireless**. The Wireless Support Resources page appears.
4. In the Wireless LAN Access section, click **Cisco Aironet 1200 Series**. The Cisco Aironet 1200 Series page appears.
5. Select the document type you want to download (for example, Configuration Guides). A list of documents for the type you selected appears.
6. Click on the link for the document you wish to view. The document you selected appears.

# Introduction to the Access Point

The Cisco Aironet 1200 Series Access Point delivers a high performance, reliable, secure, and easily managed wireless LAN solution for enterprise customers and for small- and medium-sized businesses. The access point is designed to incorporate new technology enhancements as they become available.

The 1200 series access point can contain two radios: a 2.4-GHz radio in an internal mini-PCI slot and a 5-GHz radio module in an external, modified cardbus slot. The access point supports one radio of each type, but does not support two 2.4-GHz or two 5-GHz radios. You can configure the radios separately, using different settings on each radio.

The access point can be configured from the factory for single-band operation. You can field upgrade an access point preconfigured for single-radio operation using a 5-GHz radio module or a 2.4-GHz radio card. You can also order a preconfigured dual radio access point (1230AG series).

The 2.4-GHz mini-PCI radio card is available in two versions:

- IEEE 802.11b mini-PCI radio card (*802.11b radio*)
- IEEE 802.11g mini-PCI radio card (*802.11g radio*)
  - Requires Cisco IOS Release 12.2 (13)JA or later

The 5-GHz radio module connects to the access point's modified card bus connector and is available in three versions:

- Low power IEEE 802.11a radio module with integrated antenna (*RM20A radio module*)
- Enhanced IEEE 802.11a radio module with dual integrated antennas (*RM21A radio module*)
  - Requires Cisco IOS Release 12.3(2)JA or later
- Enhanced IEEE 802.11a radio module with dual external RP-TNC antenna connectors (*RM22A radio module*)
  - Requires Cisco IOS Release 12.3 (2)JA or later



---

**Tip**

If you are upgrading to an 802.11g radio or an RM21A or RM22A radio module, make sure you are running the correct Cisco IOS version before you install the radio or module. If your access point is running an earlier version, it will not recognize the radio or module and continually boot.

---

All 5-GHz radios incorporate an Unlicensed National Information Structure (UNII) radio transceiver operating in the UNII 5-GHz frequency bands. The RM20A and RM21A contain dual integrated omnidirectional antennas for

diversity operation. In the graphical user interface (GUI) and the command line interface (CLI), The 802.11b or 802.11g radio is referred to as *Radio0* and the 802.11a radio is referred to as *Radio1*.

This guide provides information about the dual-band configuration running the Cisco IOS operating system. Your access point configuration may vary depending on the configuration you ordered.

## Safety Information

The FCC with its action in ET Docket 96-8 has adopted a safety standard for human exposure to radio frequency (RF) electromagnetic energy emitted by FCC certified equipment. When used with approved Cisco Aironet antennas, Cisco Aironet products meet the uncontrolled environmental limits found in OET-65 and ANSI C95.1, 1991. Proper installation of this radio according to the instructions found in this manual and the *Cisco Aironet 1200 Series Access Point Hardware Installation Guide* will result in user exposure that is substantially below the FCC recommended limits.

- Do not touch or move antenna(s) while the unit is transmitting or receiving.
- Do not hold any component containing a radio such that the antenna is very close to or touching any exposed parts of the body, especially the face and eyes, while transmitting.

- The use of wireless devices in hazardous locations is limited to the constraints posed by the local codes, the national codes, and the safety directors of such environments.

## Warnings

Translated warnings of safety warnings are provided in a separate document and in the *Cisco Aironet 1200 Series Access Point Hardware Installation Guide*.



**Warning**

---

**Read the installation instructions before you connect the system to its power source.** Statement 1004

---



**Warning**

---

**This product relies on the building's installation for short-circuit (overcurrent) protection. Ensure that the protective device is rated not greater than 20A.** Statement 1005

---



**Warning**

---

**Do not operate a portable transmitter near unshielded blasting caps or in an explosive environment unless it is a type especially qualified for such use.** Statement 245B

---



---

**Warning**

**Do not work on the system or connect or disconnect cables during periods of lightning activity.** Statement 1001

---



---

**Warning**

**In order to comply with FCC RF exposure limits, dipole antennas should be located at a minimum of 7.9 in. (20 cm) from the bodies of all persons.** Statement 332

---

## Unpacking the Access Point

Follow these steps to unpack the access point:

1. Open the shipping container and carefully remove the contents.
2. Return all packing materials to the shipping container and save it.
3. Ensure that all items listed in the “Package Contents” section are included in the shipment. Check each item for damage. If any item is missing or damaged, notify your authorized Cisco sales representative.



---

**Note**

Antennas for the 2.4-GHz radio are not included in the shipping container and must be ordered separately.

---

# Package Contents

Each access point package contains the following items:

- Cisco Aironet 1200 Series Access Point
- Cisco Aironet 1200 Series Power Module (Universal power supply)
- Cisco product registration and Cisco documentation feedback cards
- This guide

## Installing the Access Point

Before you begin the installation process, please refer to the following illustrations to familiarize yourself with the access point's layout, features, and connections.

This illustration shows the access point layout and connectors.

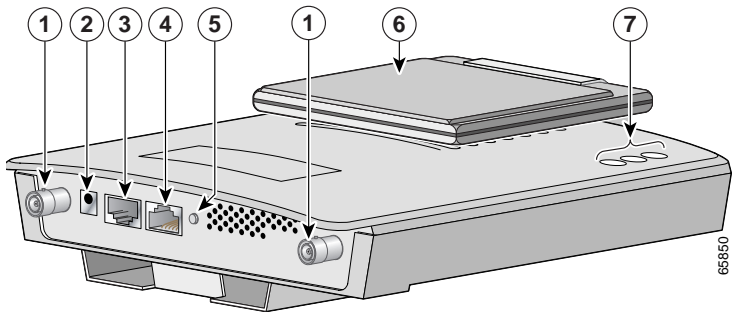

1	2.4-GHz antenna connectors	5	Mode button
2	48-VDC power port	6	5-GHz antenna
3	Ethernet port (RJ-45)	7	Status LEDs
4	Console port (RJ-45)		

This illustration shows the access point with 5-GHz radio module (RM20A or RM21A)

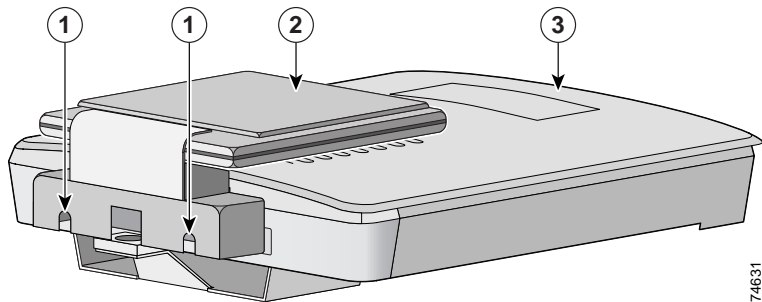

74631

<b>1</b>	Module mounting screws	<b>3</b>	Access point
<b>2</b>	Integrated antenna in patch position (RM20A or RM21A radio module)		

This illustration shows the RM22A radio module with external RP-TNC antenna connectors.

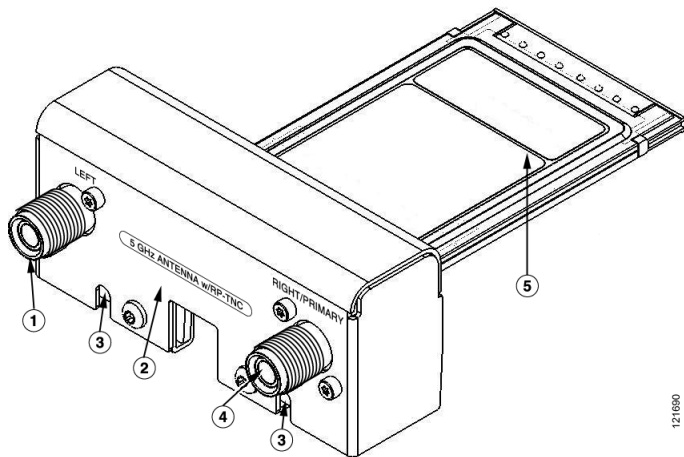

121090

1	Left RP-TNC antenna connector	4	Right/primary RP-TNC antenna connector
2	5-GHz RP-TNC label	5	5-GHz radio card
3	Module mounting screws		

**Note**

---

See the *Cisco Aironet 1200 Series Access Point Hardware Installation Guide* for a detailed description of the connections.

---

## Additional Requirements

Before you install the access point, make sure you are using a computer connected to the same network as the access point, and obtain the following information from your system administrator:

- A host name (system name) for the access point
- The case-sensitive wireless service set identifier (SSID) for your radio network
- If not connected to a DHCP server, a unique IP address for your access point (such as 172.17.255.115)
- If the access point is not on the same subnet as your PC, a default gateway address and subnet mask
- A Simple Network Management Protocol (SNMP) community name and the SNMP file attribute (if SNMP is in use)



---

**Note**

Plan to configure the access point before mounting it in a relatively inaccessible location. Some steps, such as those requiring a serial cable, are easier to perform if the access point is accessible.

---

## Attaching and Adjusting the Antennas

### 2.4-GHz Antennas

The access point supports single antenna or dual diversity antennas. Two RP-TNC connectors are provided on the back of the unit for the 2.4-GHz radio.

Attach the antennas to the RP-TNC connectors on the back of the access point and hand tighten.

If you are using one antenna, attach the antenna or antenna cable to the **2.4-GHz Right/Primary** RP-TNC connector.

If you are using two antennas for diversity coverage, attach the second antenna or antenna cable to the **2.4-GHz Left** RP-TNC antenna connector.

If you are using a Cisco Aironet 2 dBi antenna, orient the antenna depending on how you intend to mount the access point.

- On a table or desk, orient the antenna straight up.
- On a vertical surface, such as a wall, orient the antenna straight up.
- On a ceiling, orient the antenna straight down.

If you are using another Cisco Aironet antenna, refer to the antenna mounting instructions that came with your antenna.

## 5-GHz Integrated Antenna

The 5-GHz integrated antenna is already installed. Deploy the antenna depending on how the access point is mounted:

- Unfold the antenna housing if the access point is mounted on a horizontal surface, such as a ceiling or desktop.
- Leave the housing in the folded position if the access point is mounted on a vertical surface, such as a wall.

## 5-GHz External Antenna

The access point supports an RM22A radio module for use with a single antenna or dual diversity antennas. Two RP-TNC antenna connectors are provided on the back of the module for the 5-GHz radio.



## Note

Be sure to connect your 5-GHz antennas to the 5-GHz radio antenna connectors. The Cisco Aironet antenna cables have a blue marker label near the antenna connector and the radio module has a corresponding label near its 5-GHz antenna connectors.

If you are using one antenna, attach the antenna or antenna cable to the **5-GHz Right/Primary** RP-TNC connector and hand tighten.

If you are using two antennas for diversity coverage, attach the second antenna or antenna cable to the **5-GHz Left** RP-TNC antenna connector.

This illustration shows the labelling of the antenna connections.

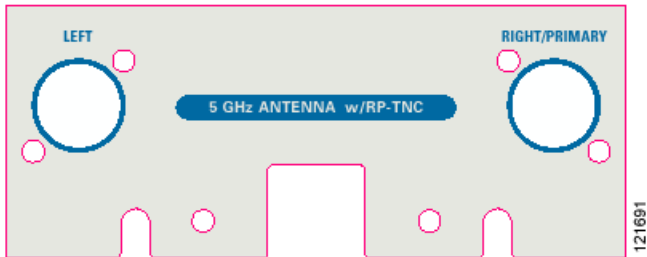

This illustration shows the connectorized version with external antennas installed.

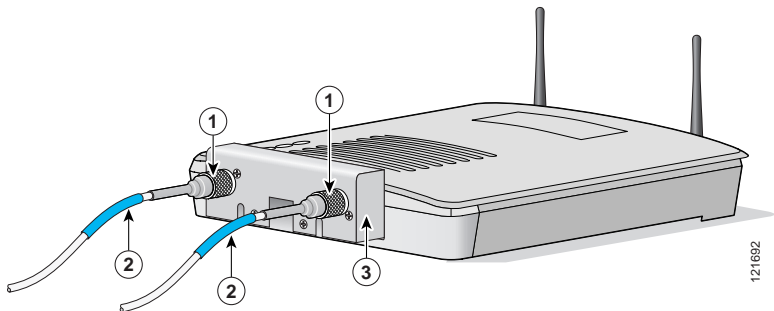

121692

1	RP-TNC antenna connector	3	5-GHz radio module
2	5-GHz antenna identifier label		

# Connecting to an Ethernet Network with an Inline Power Source

Follow these steps to connect the access point to the Ethernet LAN when you have an inline power source:

1. Connect the Ethernet cable to the RJ-45 Ethernet connector labeled *Ethernet* on the access point. Connect the other end of the cable to one of the following:



---

## Caution

Both the Ethernet and console ports use RJ-45 connectors. Be careful when connecting the Ethernet cable to avoid connecting to the console port.

---

- a. A switch with inline power, such as a Cisco Catalyst 3550-24 PWR.
- b. An inline power switch panel, such as a Cisco Catalyst Inline Power Patch Panel.
- c. The end of a Cisco Aironet power injector labeled *To AP/Bridge* and the other end labeled *To Network* to the 10/100 Ethernet LAN.

# Connecting to an Ethernet Network with Local Power

Follow these steps to connect the access point to an Ethernet LAN when you have a local power source:

1. Connect the Ethernet cable to the RJ-45 Ethernet connector labeled *Ethernet* on the access point.



---

## Caution

Both the Ethernet and console ports use RJ-45 connectors. Make sure that you connect the Ethernet cable to the Ethernet port and not to the console port.

---

2. Connect the power pack's power output connector to the 48-VDC power port labeled *48VDC* on the access point.
3. Plug the other end of the power pack into an approved 100 to 240 VAC outlet.

## Powering Up the Access Point

When power is applied to the access point, it begins a routine power-up sequence that you can monitor by observing the three LEDs on top of the access point. All three LEDs on the top of the access point (Radio, Status, and

Infrastructure) slowly blink amber, red, and green in sequence; the sequence takes a couple of minutes to complete. Because the radios are disabled, the Radio LED is dark.



---

**Note**

See the *Cisco Aironet 1200 Series Access Point Hardware Installation Guide* for a detailed description of the LED displays.

---

When the sequence is complete, you are ready to associate an IP address with the access point and perform an initial configuration.

## Obtaining and Assigning an IP Address

To browse to the access point's Express Setup page, you must either obtain or assign the access point's IP address using one of the following methods:

- Connect to the access point console port and assign a static IP address.
- Use a DHCP server (if available) to automatically assign an IP address. You can find out the DHCP-assigned IP address using one of the following methods:
  - Connect to the access point console port and use the **show ip interface brief** command to display the IP address.
  - Query the DHCP server using the access point's MAC address to identify the IP address. Your network administrator can do this.

## Using the Access Point's Console Port

You can identify or assign an IP address using the access point's console port and a terminal emulator for all operating systems. However, if your computer's operating system is Windows CE, Linux, or Mac OS, you must use the access point's command-line console.

To access the command-line console, connect a DB-9 to RJ-45 serial cable (Cisco part number AIR-CONCAB-1200) from your PC to the RS-232 console port on the access point. Then open a terminal emulator to view the express setup screen and identify the IP address. Use these port settings for the terminal session: 9600 baud, no parity, 8 data bits, 1 stop bit, and no flow control.



---

### Caution

Both the Ethernet and console ports use RJ-45 connectors. Be careful when connecting the console cable to avoid connecting to the Ethernet port.

---

Procedures for using the command-line console can be found in the *Cisco Aironet 1200 Series Access Point Hardware Installation Guide*. The guide is available on [Cisco.com](http://Cisco.com).

## Configuring the Access Point

After you have determined or assigned the access point's IP address, you can open the access point management pages and initially configure the access point. The access point must be connected to your network and your PC must be on the same subnet. Follow these steps.

1. Open your Internet browser. You must use Microsoft Internet Explorer (version 4.0 or later) or Netscape Navigator/ Communicator (version 4.0 or later).
2. Enter the access point's IP address in the browser address line and press **Enter**. The Summary Status screen appears.
3. From the Summary Status screen, click **Setup** and **Express Setup**. The Express Setup screen appears.



- HOME
- EXPRESS SET-UP
- EXPRESS SECURITY
- NETWORK MAP
- ASSOCIATION
- NETWORK INTERFACES
- SECURITY
- SERVICES
- WIRELESS SERVICES
- SYSTEM SOFTWARE
- EVENT LOG

Hostname

uptime is hours, minutes

### Express Set-Up

Host Name:

MAC Address: 00b.5f19.6659

Configuration Server Protocol:  DHCP  Static IP

IP Address:

IP Subnet Mask:

Default Gateway:

SNMP Community:

Read-Only  Read-Write

### Radio0-802.11B

Role in Radio Network:  Access Point Root  Repeater Non-Root

Workgroup Bridge

Optimize Radio Network for:  Throughput  Range  [Custom](#)

Aironet Extensions:  Enable  Disable

### Radio1-802.11A

Role in Radio Network:  Access Point Root  Repeater Non-Root

Workgroup Bridge

Optimize Radio Network for:  Throughput  Range  Default  [Custom](#)

Aironet Extensions:  Enable  Disable

Apply

Cancel

127788

4. Enter the configuration settings you obtained from your system administrator. The configurable settings include:
- Host Name**—The host name helps identify the access point on your network



---

**Note**

When you change the host name, the access point resets the radios, causing associated clients to disassociate and quickly reassociate.

---

- Configuration Server Protocol**—Click the button that matches the network's method of IP address assignment: **DHCP** or **Static IP**.
- IP Address**—Use this setting to assign or change the access point's IP address. If DHCP is enabled for your network, leave this field blank.
- IP Subnet Mask**—Enter the IP subnet mask provided by your network administrator so the IP can be recognized on the LAN. If DHCP is enabled, leave this field blank.
- Default Gateway**—Enter the default gateway IP address provided by your network administrator. If DHCP is enabled, leave this field blank.

- f. **SNMP Community**—If your network uses SNMP, enter the SNMP Community name provided by your network administrator and select the attributes of the SNMP data (also provided by your network administrator).
- g. **Role in Radio Network**—Click the button that describes the role of the access point in your network. Select **Access Point (Root)** if your access point is connected to the wired LAN. Select **Repeater (Non-Root)** if it is not connected to the wired LAN. Select **Workgroup Bridge** if you desire the access point to become a workgroup bridge.



---

**Note**

Configuring the access point as a workgroup bridge has restrictions. For more information, see the *Cisco Aironet 1200 Series Access Point Hardware Installation Guide*.

---

- h. **Optimize Radio Network for**—Use this setting to select either preconfigured or customized settings for the access point radio. **Throughput** optimizes the data volume handled by the access point but might reduce its range. **Range** maximizes range but might reduce throughput. **Default** uses the settings shipped from Cisco. **Custom** uses the settings you enter on the Network Interfaces: Radio-801.11b Settings page.

- i. **Aironet Extensions**—Enable this setting if there are only Cisco Aironet devices on your wireless LAN.
5. Click **Apply** or **OK** to save your settings. If you changed the access point's IP address, you lose your connection to the access point. Browse to the new IP address to reconnect.



---

**Note**

You can restore the access point to its factory defaults by unplugging the power jack and plugging it back in while holding down the Mode button for a few seconds or until the Status LED turns amber.

---

## Configuring Security Settings

Cisco IOS Release 12.2 (15)JA and later include an Express Security page. After you assign basic settings to your access point, you must configure security settings to prevent unauthorized access to your network. Because it is a radio device, the access point can communicate beyond the physical boundaries of your work site.

Just as you use the Express Setup page to assign basic settings, you can use the Express Security page to create unique SSIDs and assign one of four security types to them. The following illustration shows the Express Security page for Cisco IOS Release 12.3(2)JA.



## Express Security Set-Up

## SSID Configuration

1. SSID   [Broadcast SSID in Beacon](#)

## 2. VLAN

No VLAN  Enable VLAN ID:  (1-4095)  Native VLAN

## 3. Security

[No Security](#)

[Static WEP Key](#)

Key 1  128 bit

[EAP Authentication](#)

RADIUS Server:  (Hostname or IP Address)

RADIUS Server Secret:

[WPA](#)

RADIUS Server:  (Hostname or IP Address)

RADIUS Server Secret:

## SSID Table

<input type="button" value="Delete"/>	SSID	VLAN	Encryption	Authentication	Key Management	Native VLAN	Broadcast SSID
<input checked="" type="radio"/>	tsunami	none	none	open	none		<input checked="" type="checkbox"/>

The following table briefly describes the four security settings you can assign to an SSID using the Express Security page. In Cisco IOS Release 12.3(4)JA or later, you must assign an SSID.

<b>Security Type</b>	<b>Description</b>
No Security	The least secure option. Use this option only for SSIDs used in a public space and assign it to a VLAN that restricts access to your network.
Static WEP Key	More secure than no security. However, static WEP keys are vulnerable to attack.
EAP Authentication	Enables 802.1x authentication. Requires an IP address and shared secret for an authentication server on your network (server authentication port 1645). You do not need to enter a WEP key.
WPA	Wi-Fi Protected Access (WPA) permits wireless access to users authenticated against a database through the services of an authentication server, then encrypts their IP traffic with stronger algorithms than those used in WEP. As with EAP authentication, you must enter the IP address and shared secret for an authentication server on your network (server authentication port 1645).

Refer to the *Aironet 1200 Series Access Points, Cisco IOS Release xx.x(x)* for complete security information and configuration procedures.

## In Case of Difficulty

If you followed the instructions in previous sections of this guide, you should have had no trouble getting your access point installed and running. However, if you did experience difficulty, help is available from Cisco. Before contacting Cisco, look for a solution to your problem in the following places:

- The troubleshooting section of the *Cisco Aironet 1200 Series Access Point Hardware Installation Guide* or the *Cisco Aironet 1200 Series Access Point Software Configuration Guide*
- The Technical Assistance Center's list of top wireless technology issues. Follow these steps to access this list:
  1. Open your browser and go to <http://www.cisco.com/>.
  2. Click **Technical Support -- Cisco TAC**.
  3. Click **Top Issues**.
  4. Scroll down and click **Wireless Technologies**.
  5. Click on the subject that addresses the problem you are experiencing.

# Assigning an IP Address Using the CLI

When you connect the access point to the wired LAN, the access point links to the network using a bridge virtual interface (BVI) that it creates automatically. Instead of tracking separate IP addresses for the access point's Ethernet and radio ports, the network uses the BVI.

When you assign an IP address to the access point using the CLI, you must assign the address to the BVI. Beginning in a privileged EXEC mode, follow these steps to assign an IP address to the access point's BVI:

	Command	Purpose
Step 1	<b>configure terminal</b>	Enter global configuration mode.
Step 2	<b>Interface bvi1</b>	Enters interface configuration mode for the BVI.
Step 3	<b>ip address <i>address mask</i></b>	Assigns an IP address and subnet mask address to the BVI.



## Note

If you used a Telnet session to connect to the access point, you lose your connection when you assign a new IP address to the BVI. If you need to continue configuring the access point using Telnet, use the new IP address to open another Telnet session to the access point.

# Using a Telnet Session to Access the CLI

Follow these steps to browse to access the CLI using a Telnet session. These steps are for a PC running Microsoft Windows with a Telnet terminal application. Check your PC operating instructions for detailed instructions.

1. Select **Start > Programs > Accessories > Telnet**.

If Telnet is not listed in your Accessories menu, select **Start > Run**, type **Telnet** in the entry field, and press **Enter**.

2. When the Telnet window appears, click **Connect** and select **Remote System**.
3. In the Host Name field, type the access point's IP address and click **Connect**.

## Mounting Instructions

You can mount the access point on any of the following surfaces:

- Horizontal or vertical flat surfaces, such as walls or ceilings
- Suspended ceilings

The access point ships with a detachable mounting bracket and the necessary mounting hardware. Because it is detachable, you can use the mounting bracket as a template to mark the positions of the mounting holes for your

installation. You then install the mounting bracket and attach the access point when you are ready. Refer to the following illustration to locate the various mounting holes for the method you intend to use.

If you plan to mount the access point in an area subject to environmental air space, Cisco recommends that you mount the access point horizontally so that its antennas are pointing down, which results in the access point complying with regulatory requirements for environmental air space.

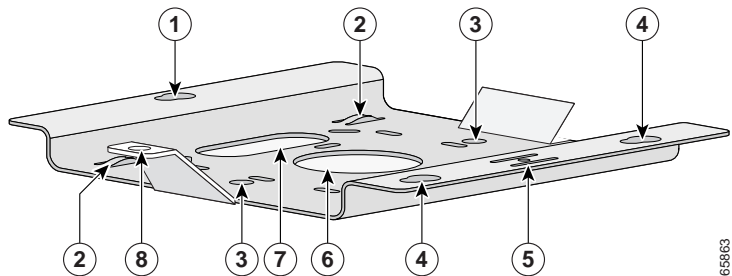

65863

1	Access point mount	5	Locking detent
2	Cable tie points	6	Security hasp
3	Ceiling mount holes	7	Cable access hole
4	Access point mounts		

A mounting hardware kit is provided that contains the hardware and fasteners necessary to mount the access point. Refer to the following table to identify the materials you need to mount your access point, then go to the section containing the specific mounting procedure.

Mounting Method	Materials Required	In Kit
Horizontal or vertical surface	Four #8 x 1 in. (25.4 mm) screws	Yes
	Four wall anchors	Yes
	3/16 in. (4.7 mm) or 3/32 in. (2.3 mm) drill bit	No
	Drill	No
	Standard screwdriver	No
Suspended ceiling	Two rail clips with studs	Yes
	Two plastic spacers	Yes
	Two 1/4–20 nuts with built-in washers	Yes
	Standard screwdriver	No
	Appropriate wrench or pliers	No

# Mounting on a Horizontal or Vertical Surface

Follow these steps to mount the access point on a horizontal or vertical surface.

1. Use the mounting bracket as a template to mark the locations of the four mounting holes.
2. Drill one of the following sized holes at the locations you marked:
  - 3/16 in. (4.7 mm) if you are using wall anchors
  - 1/8 in. (6.3 mm) if you are not using wall anchors
3. Install the anchors into the wall if you are using them. Otherwise, go to Step 4.
4. Secure the mounting bracket to the surface using the #8 fasteners.



---

**Note**

On a vertical surface, be sure to mount the bracket with its security hasp facing down.

---

5. Attach the access point to the mounting bracket.

## Mounting on a Suspended Ceiling

The 1200 series wireless devices provide adequate fire resistance and low smoke-producing characteristics suitable for operation in a building's environmental air space in accordance with Section 300-22(C) of the National Electrical Code (NEC), such as above suspended ceilings.



---

**Note** To comply with NEC code, a #10-24 grounding lug is provided on the mounting bracket.

---

Follow these steps to mount your access point on a suspended ceiling. It may be helpful to refer to the following illustration before beginning the process.

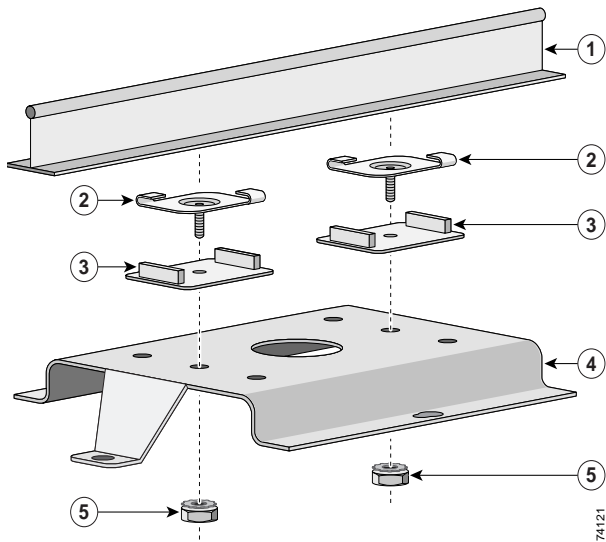

74121

<b>1</b>	Suspended ceiling T-rail	<b>4</b>	Mounting bracket
<b>2</b>	Rail clip	<b>5</b>	1/4-20 nut with attached washer
<b>3</b>	Plastic spacer		

1. Decide where you want to mount the access point.
2. Attach two rail clips to the ceiling's T-rail.
3. Use the mounting bracket to adjust the distance between the rail clips so that they align with the holes in the mounting bracket.
4. Use a standard screwdriver to tighten the rail clip studs in place on the T-rail. Do not overtighten.
5. Install a plastic spacer on each rail clip stud. The spacer's legs should contact the ceiling grid T-rail.
6. Attach the mounting bracket to the rail clip studs and start a 1/4-20 nut with attached washer on each stud.
7. Use a wrench or pliers to tighten the nuts. Do not overtighten.
8. Attach the access point to the mounting bracket.

## **Attaching the Access Point to the Mounting Bracket**

Follow these steps to attach the access point to the mounting bracket.

1. Line up the three mounting pins on the access point with the large ends of the keyhole-shaped holes on the mounting bracket.
2. Insert the access point into the keyhole shaped holes and maintain a slight pressure to hold it in place.

3. Slide the access point's mounting pins into the small ends of the keyhole-shaped holes on the mounting bracket and apply a slight force on the I/O panel end. You will hear a click when the locking detent contacts the access point and locks it into place.
4. Attach and adjust the antenna(s).
5. Connect the Ethernet cable to the access point's Ethernet port.
6. Insert the 48-VDC power output connector into the access point's local power plug (if you are using a local power source).

## Securing the Access Point to the Mounting Bracket

The security hasp on the mounting bracket locks the access point to the bracket to make it more secure. When the access point is properly installed on the mounting bracket, the holes in the security hasps line up so you can install a padlock.



---

**Note**

Known compatible padlocks are Master Lock models 120T or 121T.

---

## Mounting in a Hazardous Location

If you intend to mount the access point in a Division 2 Hazardous Location, it must be installed according to the following illustration.

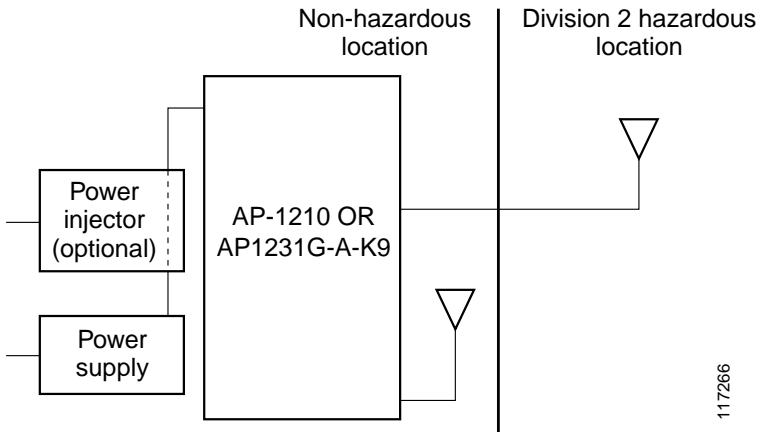

117266

Option for mounting in hazardous locations applicable for AIR-AP-1210 and AIR-AP1231G-A-K9 part numbers only.

# Compliance Information

This equipment has been tested and found to comply with the European Telecommunications Standard ETS 300.328 (2.4-GHz version) and ETS 301.893 (5-GHz version). This standard covers Wideband Data Transmission Systems referred to in CEPT recommendation T/R 10.01.

This type-accepted equipment is designed to provide reasonable protection against harmful interference when the equipment is operated in a commercial environment. This equipment generates, uses, and can radiate radio frequency energy and, if not installed in accordance with the instruction manual, may cause harmful interference to radio communications.

# Cisco One-Year Limited Hardware Warranty Terms

There are special terms applicable to your hardware warranty and various services that you can use during the warranty period. Your formal Warranty Statement, including the warranties and license agreements applicable to Cisco software, is available on Cisco.com. Follow these steps to access and download the *Cisco Information Packet* and your warranty and license agreements from Cisco.com.

1. Launch your browser, and go to this URL:  
[http://www.cisco.com/univercd/cc/td/doc/es\\_inpkc/cetrans.htm](http://www.cisco.com/univercd/cc/td/doc/es_inpkc/cetrans.htm)  
The Warranties and License Agreements page appears.
2. To read the *Cisco Information Packet*, follow these steps:
  - a. Click the **Information Packet Number** field, and make sure that the part number 78-5235-03A0 is highlighted.
  - b. Select the language in which you would like to read the document.
  - c. Click **Go**.

The Cisco Limited Warranty and Software License page from the Information Packet appears.

- d. Read the document online, or click the **PDF** icon to download and print the document in Adobe Portable Document Format (PDF).



---

**Note**

You must have Adobe Acrobat Reader to view and print PDF files. You can download the reader from Adobe's website: <http://www.adobe.com>

---

3. To read translated and localized warranty information about your product, follow these steps:
  - a. Enter this part number in the Warranty Document Number field:  
78-10747-01C0
  - b. Select the language in which you would like to view the document.
  - c. Click **Go**.  
The Cisco warranty page appears.
  - d. Read the document online, or click the **PDF** icon to download and print the document in Adobe Portable Document Format (PDF).

You can also contact the Cisco service and support website for assistance:  
[http://www.cisco.com/public/Support\\_root.shtml](http://www.cisco.com/public/Support_root.shtml).

## Duration of Hardware Warranty

One (1) Year

## Replacement, Repair, or Refund Policy for Hardware

Cisco or its service center will use commercially reasonable efforts to ship a replacement part within ten (10) working days after receipt of a Return Materials Authorization (RMA) request. Actual delivery times can vary, depending on the customer location.

Cisco reserves the right to refund the purchase price as its exclusive warranty remedy.

### To Receive a Return Materials Authorization (RMA) Number

Contact the company from whom you purchased the product. If you purchased the product directly from Cisco, contact your Cisco Sales and Service Representative.

Complete the information below, and keep it for reference.

Company product purchased from	
Company telephone number	
Product model number	
Product serial number	
Maintenance contract number	