



Cisco H.323 Signaling Interface Overview

Introduction

This chapter provides an overview of the Cisco H.323 Signaling Interface (HSI) system and subsystems and contains the following sections:

- [Cisco HSI Overview, page 1-1](#)
- [Cisco HSI System Description, page 1-2](#)
- [Operational Environment, page 1-4](#)
- [Cisco HSI Recovery, page 1-5](#)
- [Cisco HSI System Limitations, page 1-5](#)

Cisco HSI Overview

The Cisco HSI adds an H.323 interface to the Cisco Public Switched Telephone Network (PSTN) Gateway (PGW 2200). This interface allows calls to be established between the PSTN and an H.323 network (see [Figure 1-1](#)).

The Cisco HSI provides the following services:

- Translation of signaling protocols for establishing, controlling, and releasing calls
- Administration of network parameters and protocol capabilities
- System and call-related statistics
- Fault reporting
- Overload management
- Event logging
- Simple Network Management Protocol (SNMP) interface

The Cisco HSI does not operate in an active/standby configuration and, therefore, does not provide the same level of redundancy as the PGW 2200, which is configured as active/standby. We therefore recommend that you use enough HSI nodes to support the number of simultaneous calls plus one. This ensures (Trunk Group Caveats dependant) that, if one HSI fails, the calls are still adequately supported by the remaining active HSIs.

Figure 1-1 Cisco HSI System Overview

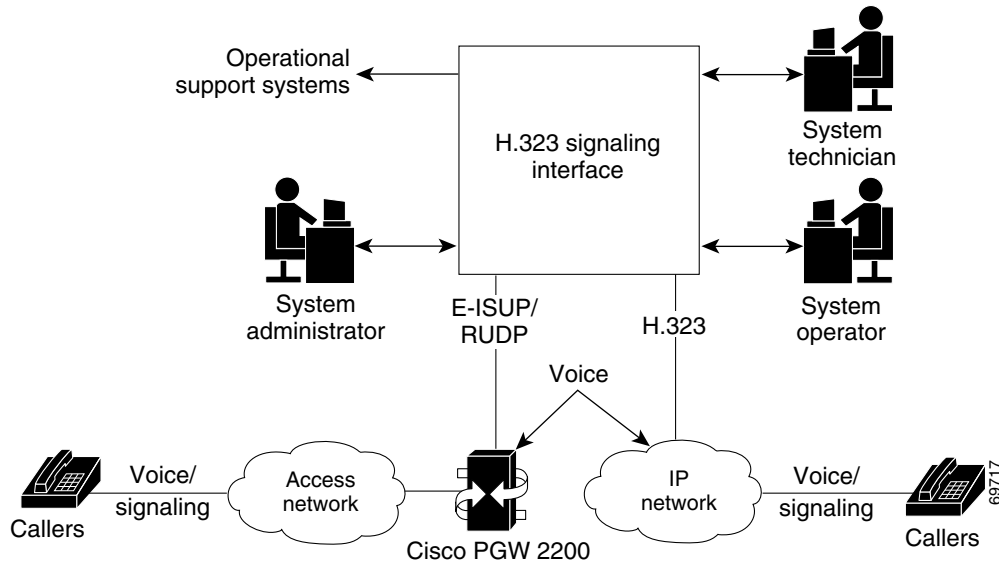

PGW 2200

The PGW 2200 consists of the hardware and software that perform the signaling and call control tasks (such as digit analysis, routing, and circuit selection) and seamlessly switch calls from the PSTN through to the IP network.

IP Network

The purpose of the Cisco HSI is to enable the PGW 2200 to interoperate with the H.323 network.

Cisco HSI System Description

The Cisco HSI system has two subsystems (see [Figure 1-2](#)):

- Operations, Administration, and Maintenance (OAM) subsystem
- Call control subsystem

Figure 1-2 Cisco HSI Subsystems

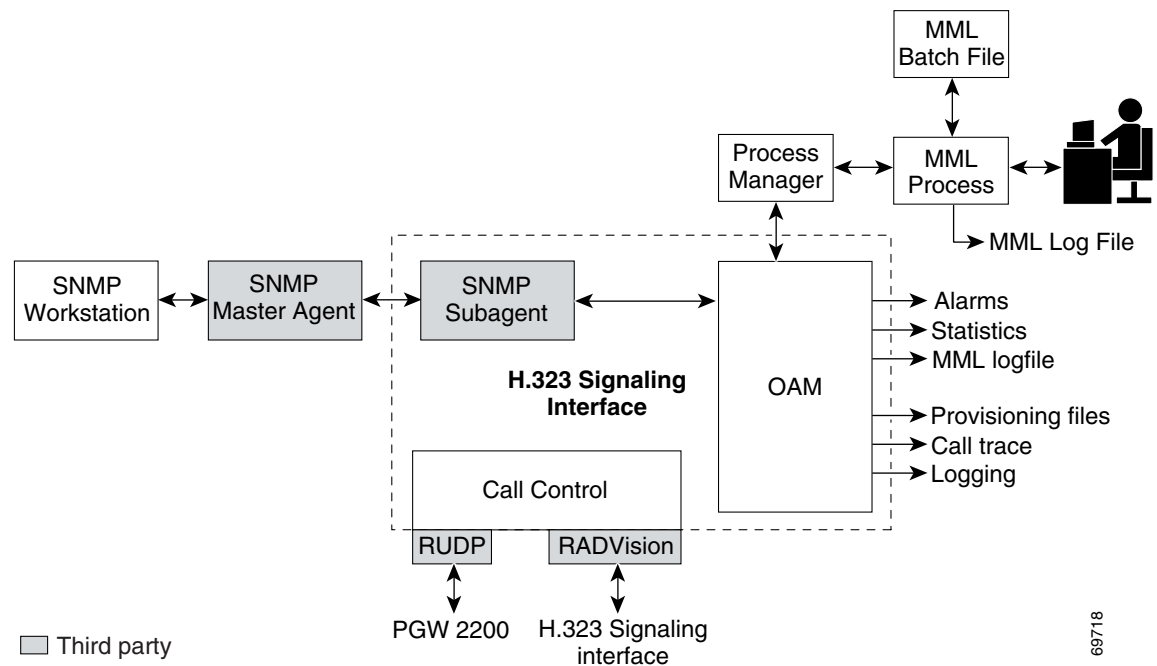

OAM Subsystem

The OAM subsystem provides the following services:

- Man-Machine Language (MML) interface that enables you to retrieve operational parameters and modify configuration values through direct input or through batch files
- SNMP interface that allows statistics and alarm retrieval
- Management to provide automatic restart of the Cisco HSI application and control over the running of the process
- Statistics, events, call trace, and alarm output to files
- Alarm events output to the MML interface
- Overload control

Call Control Subsystem

The call control subsystem provides the following services:

- Manages the Reliable User Data Protocol (RUDP) and H.323 stacks
- Implements Enhanced ISDN User Part (E-ISUP)
- Manages H.323 call control
- Performs the conversion of calls between H.323 and E-ISUP call control messages
- Provides call management and overload reduction actions

RUDP

RUDP transports the E-ISUP messages between the PGW 2200 and the Cisco HSI.

RUDP is a Cisco proprietary, connection-oriented, packet-based transport protocol.

RADVision H.323

The Cisco HSI 4.1 release uses the RADVision 4.1 H.323 stack. The HSI uses the H.225 (Q.931 and registration, admission, and status [RAS] protocol) and H.245 protocols to implement the H.323 gateway signaling function.

RADVision H.323 enables the creation of real-time voice H.323 calls over IP networks.

E-ISUP

E-ISUP is a proprietary Cisco protocol based on ISUP. E-ISUP is used for inter-PGW 2200 call control. E-ISUP uses a subset of ISUP messages. The main differences between ISUP and E-ISUP are as follows:

- E-ISUP is for the control of packet voice connection. It does not have circuit management messages such as circuit reset and blocking.
- E-ISUP is transported over RUDP in an IP network.
- E-ISUP enables PGW 2200s to transport Session Description Protocol (SDP) information (such as endpoint IP address and codec specifications) for call endpoints.

The Cisco HSI provides a conversion between the E-ISUP call control protocol originating from the PGW 2200 and the H.323 call control protocol originating from the IP network (see [Figure 1-1](#)).

New Features in Cisco HSI Release 4.1

The features introduced in the Cisco HSI 4.1 release are:

- Support of H.323 Version 4
- Invocation of Empty Capabilities Set
- Notify Support
- Disk Mirroring
- Additional security features

Operational Environment

This section provides operational environment requirements for the Cisco HSI.

Hardware Requirements

The hardware requirements for the Cisco HSI are documented in the *Cisco Media Gateway Controller Hardware Installation Guide*. See the section “Cisco MGC Host Platforms” in Chapter 1.

Software Requirements

The software requirements for the Cisco HSI are documented in the *Cisco Media Gateway Controller Software Release 9 Installation and Configuration Guide*.

Security

The application does not directly provide security features. All security must be implemented at the UNIX level.

Cisco HSI Recovery

The Cisco HSI automatically restarts the main application process if that process terminates.

**Note**

If the system is rebooted, the HSI is not started automatically unless the HSI was already activated prior to the reboot.

Cisco HSI System Limitations

The Cisco HSI does not implement security features.

**Note**

You cannot run the Cisco HSI on the same hardware platform with the Cisco PGW.
