



# Release Notes for Cisco Intrusion Prevention System 6.2(1)E3

---

**Published:** May 6, 2009, OL-15642-01

**Revised:** August 16, 2011

## Contents

- [IPS 6.2\(1\)E3 File List, page 2](#)
- [Supported Platforms, page 3](#)
- [Supported Servers, page 3](#)
- [ROMMON and TFTP, page 4](#)
- [IPS Management and Event Viewers, page 4](#)
- [New and Changed Information, page 5](#)
- [MySDN Decommissioned, page 5](#)
- [Cisco Security Intelligence Operations, page 6](#)
- [IPv6, Switches, and Lack of VACL Capture, page 6](#)
- [Before Upgrading to Cisco IPS 6.2\(1\)E3, page 7](#)
- [Upgrading to Cisco IPS 6.2\(1\)E3, page 15](#)
- [After Upgrading to Cisco IPS 6.2\(1\)E3, page 18](#)
- [Installing or Upgrading Cisco IME and Migrating Data Into IME, page 24](#)
- [Restrictions and Limitations, page 26](#)
- [Recovering the Password, page 28](#)
- [Caveats, page 35](#)
- [Related Documentation, page 40](#)
- [Obtaining Documentation and Submitting a Service Request, page 40](#)



---

**Americas Headquarters:**  
**Cisco Systems, Inc., 170 West Tasman Drive, San Jose, CA 95134-1706 USA**

© 2008-2010 Cisco Systems, Inc. All rights reserved.

**Caution**

The BIOS on Cisco IPS sensors is specific to Cisco IPS sensors and must only be upgraded under instructions from Cisco with BIOS files obtained from the Cisco website. Installing a non-Cisco or third-party BIOS on Cisco IPS sensors voids the warranty.

## IPS 6.2(1)E3 File List

The following files are part of Cisco IPS 6.2(1)E3:

- Readme
  - IPS-6.2-1-E3.readme.txt
- Minor Version Upgrade File
  - IPS-K9-6.2-1-E3.pkg
  - IPS-AIM-K9-6.2-1-E3.pkg
  - IPS-NME-K9-6.2-1-E3.pkg
- System Image Files
  - IPS-4240-K9-sys-1.1-a-6.2-1-E3.img
  - IPS-4255-K9-sys-1.1-a-6.2-1-E3.img
  - IPS-4260-K9-sys-1.1-a-6.2-1-E3.img
  - IPS-4270\_20-K9-sys-1.1-a-6.2-1-E3.img
  - WS-SVC-IDSM2-K9-sys-1.1-a-6.2-1-E3.bin.gz
  - IPS-SSC\_5-K9-sys-1.1-a-6.2-1-E3.img
  - IPS-SSM\_10-K9-sys-1.1-a-6.2-1-E3.img
  - IPS-SSM\_20-K9-sys-1.1-a-6.2-1-E3.img
  - IPS-SSM\_40-K9-sys-1.1-a-6.2-1-E3.img
  - IPS-AIM-K9-sys-1.1-a-6.2-1-E3.img
  - IPS-NME-K9-sys-1.1-a-6.2-1-E3.img
- Recovery Image Files
  - IPS-K9-r-1.1-a-6.2-1-E3.pkg
  - IPS-AIM-K9-r-1.1-a-6.2-1-E3.pkg
  - IPS-NME-K9-r-1.1-a-6.2-1-E3.pkg
  - SSC\_5 IPS-SSC\_5-K9-r-1.1-a-6.2-1-E3.pkg

**For More Information**

For the procedure for obtaining these files on Cisco.com, see [Obtaining Software on Cisco.com](#), page 10.

## Supported Platforms

**Note**

All IPS platforms allow ten concurrent CLI sessions.

**Note**

The AIM IPS and the NME IPS do not support the IPv6 features, because the routers in which they are installed do not send them IPv6 data. IPv6 inspection may work on the IDSM2, but we do not officially support it. There is no support for IPv6 on the management (command and control) interface. With ASA 8.2(1), the AIP SSM and AIP SSC-5 support IPv6 features.

Cisco IPS 6.2(1)E3 is supported on the following platforms:

- IPS 4240 Series Sensor Appliances
- IPS 4255 Series Sensor Appliances
- IPS 4260 Series Sensor Appliances
- IPS 4270-20 Series Sensor Appliances
- Intrusion Detection System Module (IDSM2) for Catalyst 6500 series switches
- ASA-SSC-AIP-5 Series Cisco ASA Advanced Inspection and Prevention Security Services Cards (AIP SSC-5)
- ASA-SSM-AIP-10 Series Cisco ASA Advanced Inspection and Prevention Security Service Modules (AIP SSM-10)
- ASA-SSM-AIP-20 Series Cisco ASA Advanced Inspection and Prevention Security Service Modules (AIP SSM-20)
- ASA-SSM-AIP-40 Series Cisco ASA Advanced Inspection and Prevention Security Service Modules (AIP SSM-40)
- Intrusion Prevention System Advanced Integration Modules (AIM IPS)
- Intrusion Prevention System Network Modules (NME IPS)

## Supported Servers

The following FTP servers are supported for IPS software updates:

- WU-FTPD 2.6.2 (Linux)
- Solaris 2.8
- Sambar 6.0 (Windows 2000)
- Serv-U 5.0 (Windows 2000)
- MS IIS 5.0 (Windows 2000)

The following HTTP/HTTPS servers are supported for IPS software updates:

- CMS - Apache Server (Tomcat)
- CMS - Apache Server (JRun)

## ROMMON and TFTP

ROMMON uses TFTP to download an image and launch it. TFTP does not address network issues such as latency or error recovery. It does implement a limited packet integrity check so that packets arriving in sequence with the correct integrity value have an extremely low probability of error. But TFTP does not offer pipelining so the total transfer time is equal to the number of packets to be transferred times the network average RTT. Because of this limitation, we recommend that the TFTP server be located on the same LAN segment as the sensor. Any network with an RTT less than a 100 milliseconds should provide reliable delivery of the image.

Some TFTP servers limit the maximum file size that can be transferred to ~32 MB. Therefore, we recommend the following TFTP servers:

- For Windows:  
Tftpd32 version 2.0, available at:  
<http://tftpd32.jounin.net/>
- For UNIX:  
Tftp-hpa series, available at:  
<http://www.kernel.org/pub/software/network/tftp/>

### For More Information

- For the procedure for downloading IPS software updates from Cisco.com, see [After Upgrading to Cisco IPS 6.2\(1\)E3, page 18](#).
- For the procedure for configuring automatic upgrades, for the CLI refer to [Configuring Automatic Upgrades](#), for IDM refer to [Configuring Automatic Update](#), and for IME refer to [Configuring Automatic Update](#).

## IPS Management and Event Viewers

Use the following tools for configuring Cisco IPS 6.2(1) sensors:

- Cisco IDM 6.2
- Cisco IME 6.2
- IPS CLI 6.2
- ASDM 5.2 and above
- CSM 3.2

Use the following tools for monitoring Cisco IPS 6.2(1) sensors:

- Cisco IME 6.2 and 7.0
- CSM 4.0



### Note

You may need to configure viewers that are already configured to monitor the Cisco IPS 6.1 sensors to accept a new SSL certificate for the Cisco IPS 6.2(1) sensors.

## New and Changed Information

Cisco IPS 6.2(1)E3 includes the following new features:

- Support for IPv6  
Cisco IPS software provides protection for both IPv4 and IPv6 networks.
- Atomic IP Advanced engine  
The Atomic IP Advanced engine enhances the detection capabilities of Cisco IPS platforms with native IPv6 inspection capabilities. The engine is active only in version 6.2 of IPS software and later.
- IME filtering, grouping, and reporting elements support IPv6 addresses in addition to IPv4 addresses.
- AIP SSC-5  
Advanced Inspection and Prevention Security Services Card. The IPS plug-in module in the Cisco ASA 5505 series adaptive security appliance. The AIP SSC-5 uses IPS services to stop malicious traffic, including worms and network viruses, before they can affect your network.
- 10GE interface card  
The 10GE interface card (part numbers IPS-2X10GE-SR-INT and IPS-2X10GE-SR-INT=) provides two 10000 Base-SX (fiber) interfaces. The IPS-4260 supports one 10GE interface card for a total of two 10GE fiber interfaces. The IPS 4270-20 supports up to two 10GE interface cards for a total of four 10GE fiber interfaces.
- The SMB engine has been replaced by the SMB Advanced engine. Even though the SMB engine is still visible in IDM, IME, and the CLI, its signatures have been obsoleted; that is, the new signatures have the obsoletes parameter set with the IDs of their corresponding old signatures. Use the new SMB Advanced engine to rewrite any custom signature that were in the SMB engine.

### For More Information

- For information on the SMB Advanced engine, refer to [Service SMB Advanced Engine](#).
- For information on the Atomic IP engines, refer to [Atomic Engine](#).
- For a list of IPv6 restrictions, see [Restrictions and Limitations, page 26](#).
- For more information on the AIP SSC-5, refer to [Introducing the Sensor](#) and [Installing the AIP SSC-5](#).
- For more information about the 10GE interface card, refer to [Installing and Removing Interface Cards in Cisco IPS 4260 and IPS 4270-20](#).

## MySDN Decommissioned

Because MySDN has been decommissioned, the URL in older versions of IDM and IME is no longer functional. If you are using IPS 6.0 or later, we recommend that you upgrade your version of IDM and IME.

You can upgrade to the following versions to get the functioning MySDN URL:

- IDM 7.0.3
- IME 7.0.3
- IPS 7.0(4), which contains IDM 7.0.4

If you are using version IPS 5.x, you must look up signature information manually at this URL:

<http://tools.cisco.com/security/center/search.x>

#### For More Information

For detailed information on MySDN, for IDM refer to [MySDN](#) and for IME refer to [MySDN](#).

## Cisco Security Intelligence Operations

The Cisco Security Intelligence Operations site on Cisco.com provides intelligence reports about current vulnerabilities and security threats. It also has reports on other security topics that help you protect your network and deploy your security systems to reduce organizational risk.

You should be aware of the most recent security threats so that you can most effectively secure and manage your network. Cisco Security Intelligence Operations contains the top ten intelligence reports listed by date, severity, urgency, and whether there is a new signature available to deal with the threat.

Cisco Security Intelligence Operations contains a Security News section that lists security articles of interest. There are related security tools and links.

You can access Cisco Security Intelligence Operations at this URL:

<http://tools.cisco.com/security/center/home.x>

Cisco Security Intelligence Operations is also a repository of information for individual signatures, including signature ID, type, structure, and description.

You can search for security alerts and signatures at this URL:

<http://tools.cisco.com/security/center/search.x>

## IPv6, Switches, and Lack of VACL Capture

VACLs on Catalyst switches do not have IPv6 support. The most common method for copying traffic to a sensor configured in Promiscuous mode is to use VACL capture. If you want to have IPv6 support, you can use SPAN ports.

However, you can only configure up to two monitor sessions on a switch unless you use the following configuration:

- Monitor session
- Multiple trunks to one or more sensors
- Restrict per trunk port which VLANs are allowed to perform monitoring of many VLANs to more than two different sensors or virtual sensors within one IPS

The following configuration uses one SPAN session to send all of the traffic on any of the specified VLANs to all of the specified ports. Each port configuration only allows a particular VLAN or VLANs to pass. Thus you can send data from different VLANs to different sensors or virtual sensors all with one SPAN configuration line:

```
clear trunk 4/1-4 1-4094
set trunk 4/1 on dot1q 930
set trunk 4/2 on dot1q 932
set trunk 4/3 on dot1q 960
set trunk 4/4 on dot1q 962
set span 930, 932, 960, 962 4/1-4 both
```

**Note**

The SPAN/Monitor configuration is valuable when you want to assign different IPS policies per VLAN or when you have more bandwidth to monitor than one interface can handle.

#### For More Information

For more information on configuring SPAN/monitor on switches, refer to the following sections in *Catalyst 6500 Series Software Configuration Guide, 8.7*:

- [Configuring SPAN, RSPAN and the Mini Protocol Analyzer](#)
- [Configuring SPAN on the Switch](#)
- [Configuring Ethernet VLAN Trunks](#)
- [Defining the Allowed VLANs on a Trunk](#)

## Before Upgrading to Cisco IPS 6.2(1)E3

This section describes the actions you should take before upgrading to Cisco IPS 6.2(1)E3. It contains the following topics:

- [Perform These Tasks, page 7](#)
- [Backing Up and Restoring the Configuration File Using a Remote Server, page 8](#)
- [Obtaining Software on Cisco.com, page 10](#)
- [IPS Software Versioning, page 11](#)
- [Software Release Examples, page 14](#)

## Perform These Tasks

Before you upgrade your sensors to Cisco IPS 6.2(1)E3, make sure you perform the following tasks:

- Check to make sure you have a valid Cisco Service for IPS service contract per sensor so that you can apply software upgrades.
- Created a backup copy of your configuration.
- Saved the output of the **show version** command.

If you need to downgrade a signature update, you will know what version you had, and you can then apply the configuration you saved when you backed up your configuration.

#### For More Information

- For more information on how to obtain a valid Cisco Service for IPS service contract, see [Service Programs for IPS Products, page 20](#).
- For the procedure for creating a backup copy of your configuration, see [Backing Up and Restoring the Configuration File Using a Remote Server, page 8](#).
- For the procedure for finding your Cisco IPS software version, for the CLI refer to [Displaying Version Information](#), for IDM refer to [IDM Home Window](#), and for IME refer to [Sensor Information Gadget](#).
- For the procedure for downgrading signature updates on your sensor, refer to [Upgrading, Downgrading, and Installing System Images](#).

## Backing Up and Restoring the Configuration File Using a Remote Server



### Note

We recommend copying the current configuration file to a remote server before upgrading.

Use the **copy** [**/erase**] *source\_url destination\_url keyword* command to copy the configuration file to a remote server. You can then restore the current configuration from the remote server. You are prompted to back up the current configuration first.

### Options

The following options apply:

- **/erase**—Erases the destination file before copying.  
This keyword only applies to the current-config; the backup-config is always overwritten. If this keyword is specified for destination current-config, the source configuration is applied to the system default configuration. If it is not specified for the destination current-config, the source configuration is merged with the current-config.
- *source\_url*—The location of the source file to be copied. It can be a URL or keyword.
- *destination\_url*—The location of the destination file to be copied. It can be a URL or a keyword.
- **current-config**—The current running configuration. The configuration becomes persistent as the commands are entered.
- **backup-config**—The storage location for the configuration backup.

The exact format of the source and destination URLs varies according to the file. Here are the valid types:

- **ftp**—Source or destination URL for an FTP network server. The syntax for this prefix is:  
ftp:[/[username@] location]/relativeDirectory]/filename  
ftp:[/[username@]location]//absoluteDirectory]/filename
- **scp**—Source or destination URL for the SCP network server. The syntax for this prefix is:  
scp:[/[username@] location]/relativeDirectory]/filename  
scp:[/[username@] location]//absoluteDirectory]/filename



### Note

If you use FTP or SCP protocol, you are prompted for a password. If you use SCP protocol, you must also add the remote host to the SSH known hosts list.

- **http**—Source URL for the web server. The syntax for this prefix is:  
http:[/[username@]location]/directory]/filename
- **https**—Source URL for the web server. The syntax for this prefix is:  
https:[/[username@]location]/directory]/filename



### Note

HTTP and HTTPS prompt for a password if a username is required to access the website. If you use HTTPS protocol, the remote host must be a TLS trusted host.

**Caution**

Copying a configuration file from another sensor may result in errors if the sensing interfaces and virtual sensors are not configured the same.

**Backing Up the Current Configuration to a Remote Server**

To back up your current configuration to a remote server, follow these steps:

**Step 1** Log in to the CLI using an account with administrator privileges.

**Step 2** Back up the current configuration to the remote server.

```
sensor# copy current-config scp://user@192.0.2.0//configuration/cfg current-config
Password: *****
Warning: Copying over the current configuration may leave the box in an unstable state.
Would you like to copy current-config to backup-config before proceeding? [yes]:
```

**Step 3** Enter **yes** to copy the current configuration to a backup configuration.

```
cfg          100% |*****| 36124          00:00
```

**Restoring the Current Configuration From a Backup File**

To restore your current configuration from a backup file, follow these steps:

**Step 1** Log in to the CLI using an account with administrator privileges.

**Step 2** Back up the current configuration to the remote server.

```
sensor# copy scp://user@192.0.2.0//configuration/cfg current-config
Password: *****
Warning: Copying over the current configuration may leave the box in an unstable state.
Would you like to copy current-config to backup-config before proceeding? [yes]:
```

**Step 3** Enter **yes** to copy the current configuration to a backup configuration.

```
cfg          100% |*****| 36124          00:00
```

```
Warning: Replacing existing network-settings may leave the box in an unstable state.
Would you like to replace existing network settings
(host-ipaddress/netmask/gateway/access-list) on sensor before proceeding? [no]:
sensor#
```

**Step 4** Enter **no** to retain the currently configured hostname, IP address, subnet mask, management interface, and access list. We recommend you retain this information to preserve access to your sensor after the rest of the configuration has been restored.

**For More Information**

For the procedure for adding trusted hosts, for the CLI refer to [Adding TLS Trusted Hosts](#), for IDM refer to [Configuring Trusted Hosts](#), and for IME refer to [Adding Trusted Hosts](#).

## Obtaining Software on Cisco.com

You can find major and minor updates, service packs, signature and signature engine updates, system and recovery files, firmware upgrades, and readmes on the Download Software site on Cisco.com. Signature updates are posted to Cisco.com approximately every week, more often if needed. Service packs are posted to Cisco.com as needed. Major and minor updates are also posted periodically. Check Cisco.com regularly for the latest IPS software.

**Note**

You must be logged in to Cisco.com to download software. You must have an active IPS maintenance contract and a Cisco.com password to download software. Beginning with Cisco IPS 5.x, you must have a license to apply signature updates.

**Downloading IPS Software**

To download software on Cisco.com, follow these steps:

- 
- Step 1** Log in to [Cisco.com](#).
  - Step 2** From the Support drop-down menu, choose **Download Software**.
  - Step 3** Under Select a Software Product Category, choose **Security Software**.
  - Step 4** Choose **Intrusion Prevention System (IPS)**.
  - Step 5** Enter your username and password.
  - Step 6** In the Download Software window, choose **IPS Appliances > Cisco Intrusion Prevention System** and then click the version you want to download.

**Note**

You must have an IPS subscription service license to download software.

- Step 7** Click the type of software file you need. The available files appear in a list in the right side of the window. You can sort by file name, file size, memory, and release date. And you can access the Release Notes and other product documentation.
- Step 8** Click the file you want to download. The file details appear.
- Step 9** Verify that it is the correct file, and click **Download**.
- Step 10** Click **Agree** to accept the software download rules. The first time you download a file from Cisco.com, you must fill in the Encryption Software Export Distribution Authorization form before you can download the software.
  - Fill out the form and click **Submit**. The Cisco Systems Inc. Encryption Software Usage Handling and Distribution Policy appears.
  - Read the policy and click **I Accept**. The Encryption Software Export/Distribution Form appears.

If you previously filled out the Encryption Software Export Distribution Authorization form, and read and accepted the Cisco Systems Inc. Encryption Software Usage Handling and Distribution Policy, these forms are not displayed again. The File Download dialog box appears.

- Step 11** Open the file or save it to your computer.
- Step 12** Follow the instructions in the Readme to install the update.



---

**Note** Major and minor updates, service packs, recovery files, signature and signature engine updates are the same for all sensors. System image files are unique per platform.

---

## IPS Software Versioning

When you download IPS software images from Cisco.com, you should understand the versioning scheme so that you know which files are base files, which are cumulative, and which are incremental.

### Major Update

A major update contains new functionality or an architectural change in the product. For example, the Cisco IPS 6.0 base version includes everything (except deprecated features) since the previous major release (the minor update features, service pack fixes, and signature updates) plus any new changes. Major update 6.0(1) requires 5.x. With each major update there are corresponding system and recovery packages.



---

**Note** The 6.0(1) major update is only used to upgrade 5.x sensors to 6.0(1). If you are reinstalling 6.0(1) on a sensor that already has 6.0(1) installed, use the system image or recovery procedures rather than the major update.

---

### Minor Update

A minor update is incremental to the major version. Minor updates are also base versions for service packs. The first minor update for 6.0 is 6.1(1). Minor updates are released for minor enhancements to the product. Minor updates contain all previous minor features (except deprecated features), service pack fixes, signature updates since the last major version, and the new minor features being released. You can install the minor updates on the previous major or minor version (and often even on earlier versions). The minimum supported version needed to upgrade to the newest minor version is listed in the Readme that accompanies the minor update. With each minor update there are corresponding system and recovery packages.

### Service Pack

A service pack is cumulative following a base version release (minor or major). Service packs are used for the release of defect fixes with no new enhancements. Service packs contain all service pack fixes since the last base version (minor or major) and the new defect fixes being released. Service packs require the minor version. The minimum supported version needed to upgrade to the newest service pack is listed in the Readme that accompanies the service pack. Service packs also include the latest engine update. For example, if service pack 6.0(3) is released, and E3 is the latest engine level, the service pack is released as 6.0(3)E3.

### Patch Release

A patch release is used to address defects that are identified in the upgrade binaries after a software release. Rather than waiting until the next major or minor update, or service pack to address these defects, a patch can be posted. Patches include all prior patch releases within the associated service pack level. The patches roll into the next official major or minor update, or service pack.

Before you can install a patch release, the most recent major or minor update, or service pack must be installed. For example, patch release 6.0(1p1) requires 6.0(1).



**Note** Upgrading to a newer patch does not require you to uninstall the old patch. For example, you can upgrade from patch 6.0(1p1) to 6.0(1p2) without first uninstalling 6.0(1p1).

Figure 1 illustrates what each part of the IPS software file represents for major and minor updates, service packs, and patch releases.

**Figure 1** *IPS Software File Name for Major and Minor Updates, Service Packs, and Patch Releases*

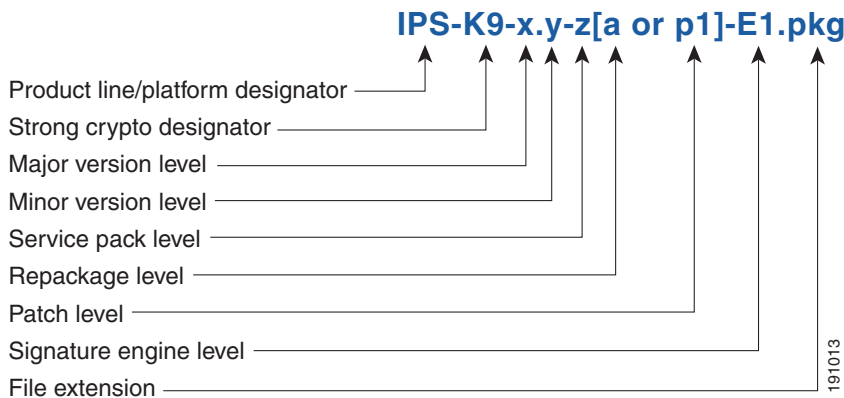

**Signature Update**

A signature update is a package file containing a set of rules designed to recognize malicious network activities. Signature updates are released independently from other software updates. Each time a major or minor update is released, you can install signature updates on the new version and the next oldest version for a period of at least six months. Signature updates are dependent on a required signature engine version. Because of this, a *req* designator lists the signature engine required to support a particular signature update.

Figure 2 illustrates what each part of the IPS software file represents for signature updates.

**Figure 2** *IPS Software File Name for Signature Updates*

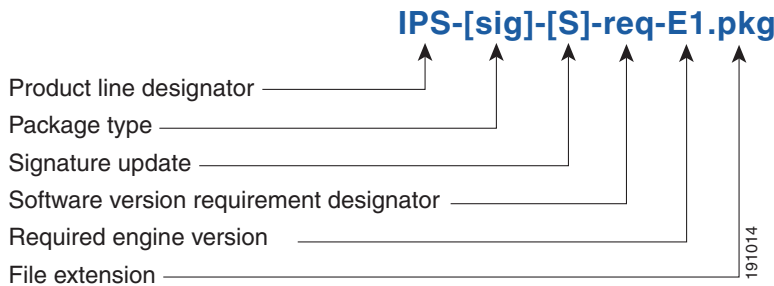

**Signature Engine Update**

A signature engine update is an executable file containing binary code to support new signature updates. Signature engine files require a specific service pack, which is also identified by the *req* designator.

Figure 3 illustrates what each part of the IPS software file represents for signature engine updates.

**Figure 3** *IPS Software File Name for Signature Engine Updates*

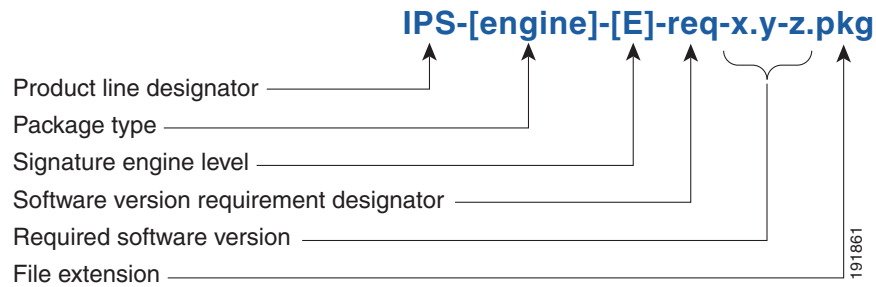

### Recovery and System Image Files

Recovery and system image files contain separate versions for the installer and the underlying application. The installer version contains a major and minor version field. The major version is incremented by one of any major changes to the image installer, for example, switching from .tar to rpm or changing kernels. The minor version can be incremented by any one of the following:

- Minor change to the installer, for example, a user prompt added.
- Repackages require the installer minor version to be incremented by one if the image file must be repackaged to address a defect or problem with the installer.

Figure 4 illustrates what each part of the IPS software file represents for recovery and system image files.

**Figure 4** *IPS Software File Name for Recovery and System Image Files*

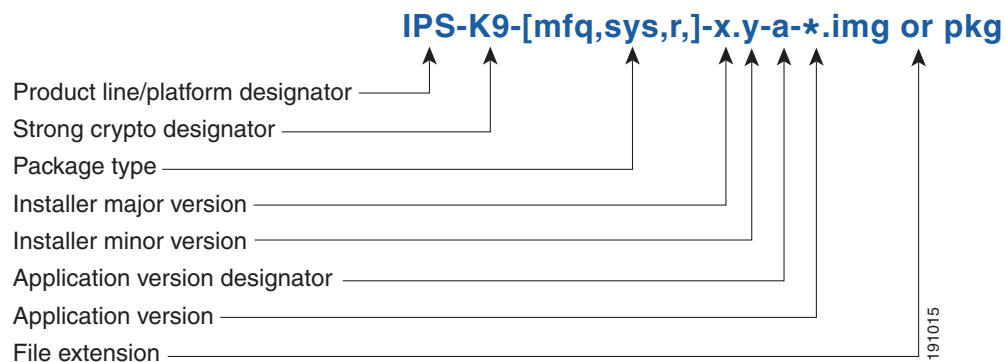

## Software Release Examples

Table 1 lists platform-independent Cisco IPS 6.x software release examples. Refer to the Readmes that accompany the software files for detailed instructions on how to install the files.

**Table 1 Platform-Independent Release Examples**

Release	Target Frequency	Identifier	Example Version	Example Filename
Signature update <sup>1</sup>	Weekly	sig	S353	IPS-sig-S353-req-E3.pkg
Signature engine update <sup>2</sup>	As needed	engine	E3	IPS-engine-E3-req-6.2-1.pkg
Service packs <sup>3</sup>	Semi-annually or as needed	—	6.1(3)	IPS-K9-6.2-3-E3.pkg
Minor version update <sup>4</sup>	Annually	—	6.1(1)	IPS-K9-6.2-1-E3.pkg  <b>Note</b> IPS-AIM-K9-6.1-1-E3.pkg is the minor version update for the AIM IPS. IPS-NME-K-9-6.1-1-E3.pkg is the minor version update for the NME IPS.
Major version update <sup>5</sup>	Annually	—	6.0(1)	IPS-K9-6.0-1-E3.pkg
Patch release <sup>6</sup>	As needed	patch	6.0(1p1)	IPS-K9-patch-6.2-1pl-E3.pkg
Recovery package <sup>7</sup>	Annually or as needed	r	1.1-6.1(1)	IPS-K9-r-1.1-a-6.2-1-E3.pkg

- Signature updates include the latest cumulative IPS signatures.
- Signature engine updates add new engines or engine parameters that are used by new signatures in later signature updates.
- Service packs include defect fixes.
- Minor versions include new minor version features and/or minor version functionality.
- Major versions include new major version functionality or new architecture.
- Patch releases are for interim fixes.
- The r 1.1 can be revised to r 1.2 if it is necessary to release a new recovery package that contains the same underlying application image. If there are defect fixes for the installer, for example, the underlying application version may still be 6.0(1), but the recovery partition image will be r 1.2.

Table 2 describes platform-dependent software release examples.

**Table 2 Platform-Dependent Release Examples**

Release	Target Frequency	Identifier	Supported Platform	Example Filename
System image <sup>1</sup>	Annually	sys	Separate file for each sensor platform	IPS-4240-K9-sys-1.1-a-6.2-1-E3.img
Maintenance partition image <sup>2</sup>	Annually	mp	IDS M2	c6svc-mp.2-1-2.bin.gz

**Table 2** Platform-Dependent Release Examples (continued)

Release	Target Frequency	Identifier	Supported Platform	Example Filename
Bootloader	As needed	bl	AIM IPS NME IPS	pse_aim_x.y.z.bin pse_nm_x.y.z.bin (where x, y, z is the release number)
Mini-kernel	As needed	mini-kernel	AIM IPS NME IPS	pse_mini_kernel_1.1.10.64.bz2

1. The system image includes the combined recovery and application image used to reimage an entire sensor.
2. The maintenance partition image includes the full image for the IDSM2 maintenance partition. The file is installed from but does not affect the IDSM2 application partition.

Table 3 describes the platform identifiers used in platform-specific names.

**Table 3** Platform Identifiers

Sensor Family	Identifier
IPS 4240 series	4240
IPS 4255 series	4255
IPS 4260 series	4260
IPS 4270-20 series	4270_20
IDS module for Catalyst 6K	IDSM2
IPS network module	AIM NME
adaptive security appliance modules	SSC_5 SSM_10 SSM_20 SSM_40

## Upgrading to Cisco IPS 6.2(1)E3

This section provides information on upgrading to Cisco IPS 6.2(1)E3, and contains the following topics:

- [Upgrade Notes and Caveats, page 15](#)
- [Upgrading to 6.2\(1\)E3, page 17](#)

## Upgrade Notes and Caveats

The following upgrade notes and caveats apply to upgrading your sensor to 6.2(1)E3:

- You must have a valid Cisco Service for IPS Maintenance contract per sensor to receive and use software upgrades from Cisco.com.
- The minimum required version for upgrading to 6.2(1)E3 is 6.0(1) or later, which is available as a download from Cisco.com.

- Use IPS-AIM-K9-6.2-1-E3.pkg to upgrade the AIM IPS and IPS-NME-K9-6.2-1-E3 to upgrade the NME IPS. For all other supported sensors, use the IPS-K9-6.2-1-E3.pkg upgrade file.
- Using automatic update:
  - If you configured automatic update for your sensor, copy the 6.2(1)E3 update files to the directory on the server that your sensor polls for updates.
  - If you are using automatic update with a mixture of IPS appliances or modules (AIM IPS or NME IPS), make sure you put all of the 6.2(1)E3 upgrade file on the automatic update server so that the modules can correctly detect which file needs to be automatically downloaded and installed. If you only put the 6.2(1)E3 upgrade file (IPS-K9-6.2-1-E3.pkg) on the server, the modules will download and try to install the wrong file.
  - When you upgrade the AIM IPS or the NME IPS using automatic update, you must disable heartbeat reset on the router before placing the upgrade file on your automatic update server. After the module has been automatically updated, you can reenale heartbeat reset. If you do not disable heartbeat reset, the upgrade can fail and leave the module in an unknown state, which can require a system reimage to recover.
- Using manual update:
  - When you upgrade the AIM IPS or the NME IPS using manual upgrade, you must disable heartbeat reset on the router before installing the upgrade. You can reenale heartbeat reset after you complete the upgrade. If you do not disable heartbeat reset, the upgrade can fail and leave the AIM IPS or the NME IPS in an unknown state, which can require a system reimage to recover.
- If you install an update on your sensor and the sensor is unusable after it reboots, you must reimage your sensor. You can reimage your sensor in the following ways:
  - For all sensors, use the **recover** command.
  - For IPS 4240, IPS 4255, IPS 4260, and IPS 4270-20, use the ROMMON to restore the system image.
  - For the AIM IPS and the NME IPS, use the bootloader.
  - For the IDSM2, reimage the application partition from the maintenance partition.
  - For the AIP SSM and the AIP SSC-5, reimage from the adaptive security appliance using the **hw-module module 1 recover configure/boot** command.

**Caution**

---

When you install the system image for your sensor, all accounts are removed and the default account and password are reset to **cisco**

---

**For More Information**

- For the procedures for reimaging sensors, refer to [Upgrading, Downgrading, and Installing System Images](#).
- For the procedure for disabling heartbeat reset, for the AIM IPS refer to [Enabling and Disabling Heartbeat Reset](#), and for the NME IPS refer to [Enabling and Disabling Heartbeat Reset](#).
- For more information on Cisco service contracts, see [Service Programs for IPS Products](#), page 20.
- For the procedure for configuring automatic upgrade, refer to [Configuring Automatic Upgrades](#).

## Upgrading to 6.2(1)E3

**Caution**

You must log in to Cisco.com using an account with cryptographic privileges to download software. The first time you download software on Cisco.com, you receive instructions for setting up an account with cryptographic privileges.

**Caution**

Do not change the filename. You must preserve the original filename for the sensor to accept the update.

To upgrade the sensor, follow these steps:

**Step 1** Download the appropriate file (for example, IPS-K9-6.2-1-E3.pkg) to an FTP, SCP, HTTP, or HTTPS server that is accessible from your sensor.

**Step 2** Log in to the CLI using an account with administrator privileges.

**Step 3** Enter configuration mode.

```
sensor# configure terminal
```

**Step 4** Upgrade the sensor.

```
sensor(config)# upgrade url/IPS-K9-6.2-1-E3.pkg
```

The URL points to where the update file is located, for example, to retrieve the update using FTP, enter the following:

```
sensor(config)# upgrade ftp://username@ip_address//directory/IPS-K9-6.2-1-E3.pkg
```

**Step 5** Enter the password when prompted.

```
Enter password: *****
```

**Step 6** Enter **yes** to complete the upgrade.

**Note**

Major updates, minor updates, and service packs may force a restart of the IPS processes or even force a reboot of the sensor to complete installation.

**Note**

The operating system is reimaged and all files that have been placed on the sensor through the service account are removed.

### For More Information

For the procedure for locating software on Cisco.com and obtaining an account with cryptographic privileges, see [Obtaining Software on Cisco.com, page 10](#).

## After Upgrading to Cisco IPS 6.2(1)E3

This section provides information about what to do after you install Cisco IPS 6.2(1)E3. It contains the following topics:

- [Comparing Configurations, page 18](#)
- [Importing a New SSL Certificate, page 18](#)
- [Logging In to IDM, page 18](#)
- [Licensing the Sensor, page 19](#)

### Comparing Configurations

Compare your backed up and saved 6.1 configuration with the output of the **show configuration** command after upgrading to 6.2(1)E3 to verify that all the configuration has been properly converted.

**Caution**

---

If the configuration is not properly converted, check the caveats for Cisco IPS 6.2(1)E3. or check Cisco.com for any upgrade issues that have been found. Contact the TAC if no DDTS refers to your situation.

---

**For More Information**

For a list of the caveats associated with this release, see [Caveats, page 35](#).

### Importing a New SSL Certificate

If necessary import the new SSL certificate for the upgraded sensor in to each tool being used to monitor the sensor.

**For More Information**

For the procedures for configuring TLS/SSL, for the CLI refer to [Configuring TLS](#), for IDM refer to [Configuring Trusted Hosts](#), and for IME refer to [Configuring Trusted Hosts](#).

### Logging In to IDM

IDM is a web-based, Java Web Start application that enables you to configure and manage your sensor. The web server for IDM resides on the sensor. You can access it through Internet Explorer or Firefox web browsers.

To log in to IDM, follow these steps:

---

**Step 1** Open a web browser and enter the sensor IP address. A Security Alert dialog box appears.

`https://sensor_ip_address`



---

**Note** IDM is already installed on the sensor.

---



**Note** The default IP address is 192.168.1.2/24,192.168.1.1, which you change to reflect your network environment when you initialize the sensor. When you change the web server port, you must specify the port in the URL address of your browser when you connect to IDM in the format `https://sensor_ip_address:port` (for example, `https://10.1.9.201:1040`).

- Step 2** Click **Yes** to accept the security certificate. The Cisco IPS Device Manager Version 6.2 window appears.
- Step 3** To launch IDM, click **Run IDM**. The JAVA loading message box appears, and then the Warning - Security dialog box appears.
- Step 4** To verify the security certificate, check the Always trust content from this publisher check box, and click **Yes**. The JAVA Web Start progress dialog box appears, and then the IDM on *ip\_address* dialog box appears.
- Step 5** To create a shortcut for IDM, click **Yes**. The Cisco IDM Launcher dialog box appears.



**Note** You must have JRE 1.5 (JAVA 5) installed to create shortcuts for IDM. If you have JRE 1.6 (JAVA 6) installed, the shortcut is created automatically.

- Step 6** To authenticate IDM, enter your username and password, and click **OK**. IDM begins to load. If you change panes from Home to Configuration or Monitoring before IDM has complete initialization, a Status dialog box appears with the following message:

Please wait while IDM is loading the current configuration from the sensor.

The main window of IDM appears.



**Note** Both the default username and password are **cisco**. You were prompted to change the password during sensor initialization.



**Note** If you created a shortcut, you can launch IDM by double-clicking the IDM shortcut icon. You can also close the Cisco IPS Device Manager Version 6.2 window. After you launch IDM, is it not necessary for this window to remain open.

## Licensing the Sensor

This section describes how to obtain a license key and how to license the sensor using the CLI, IDM, or IME. It contains the following topics:

- [Understanding the License, page 20](#)
- [Service Programs for IPS Products, page 20](#)
- [Obtaining and Installing the License Key, page 21](#)

## Understanding the License

Although the sensor functions without the license key, you must have a license key to obtain signature updates. To obtain a license key, you must have the following:

- Cisco Service for IPS service contract

Contact your reseller, Cisco service or product sales to purchase a contract.

- Your IPS device serial number

To find the IPS device serial number in IDM or IME, for IDM choose **Configuration > Sensor Management > Licensing**, and for IME choose **Configuration > sensor\_name > Sensor Management > Licensing**, or in the CLI use the **show version** command.

- Valid Cisco.com username and password

Trial license keys are also available. If you cannot get your sensor licensed because of problems with your contract, you can obtain a 60-day trial license that supports signature updates that require licensing.

You can obtain a license key from the Cisco.com licensing server, which is then delivered to the sensor.

Or, you can update the license key from a license key provided in a local file. Go to

<http://www.cisco.com/go/license> and click **IPS Signature Subscription Service** to apply for a license key.

You can view the status of the license key in these places:

- IDM Home window Licensing section on the Health tab
- IDM Licensing pane (**Configuration > Licensing**)
- IME Home page in the Device Details section on the Licensing tab
- License Notice at CLI login

Whenever you start IDM, IME, or the CLI, you are informed of your license status—whether you have a trial, invalid, or expired license key. With no license key, an invalid license key, or an expired license key, you can continue to use IDM, IME, and the CLI, but you cannot download signature updates.

If you already have a valid license on the sensor, you can click **Download** on the License pane to download a copy of your license key to the computer that IDM or IME is running on and save it to a local file. You can then replace a lost or corrupted license, or reinstall your license after you have reimaged the sensor.

## Service Programs for IPS Products

You must have a Cisco Services for IPS service contract for any IPS product so that you can download a license key and obtain the latest IPS signature updates. If you have a direct relationship with Cisco Systems, contact your account manager or service account manager to purchase the Cisco Services for IPS service contract. If you do not have a direct relationship with Cisco Systems, you can purchase the service account from a one-tier or two-tier partner.

When you purchase the following IPS products you must also purchase a Cisco Services for IPS service contract:

- IPS 4240
- IPS 4255
- IPS 4260
- IPS 4270-20
- AIM IPS

- IDSM2
- NME IPS

When you purchase an ASA 5500 series adaptive security appliance product that does not contain IPS, you must purchase a SMARTnet contract.



**Note** SMARTnet provides operating system updates, access to Cisco.com, access to TAC, and hardware replacement NBD on site.

When you purchase an ASA 5500 series adaptive security appliance product that ships with the AIP SSM or the AIP SSC-5 installed, or if you purchase them to add to your ASA 5500 series adaptive security appliance product, you must purchase the Cisco Services for IPS service contract.



**Note** Cisco Services for IPS provides IPS signature updates, operating system updates, access to Cisco.com, access to TAC, and hardware replacement NBD on site.

For example, if you purchased an ASA 5510 and then later wanted to add IPS and purchased an ASA-SSM-AIP-10-K9, you must now purchase the Cisco Services for IPS service contract. After you have the Cisco Services for IPS service contract, you must also have your product serial number to apply for the license key.



**Caution**

If you ever send your product for RMA, the serial number will change. You must then get a new license key for the new serial number.

## Obtaining and Installing the License Key

You can install the license key through the CLI, IDM, IME. This section describes how to obtain and install the license key, and contains the following topics:

- [Using IDM or IME, page 21](#)
- [Using the CLI, page 22](#)

### Using IDM or IME



**Note**

In addition to a valid Cisco.com username and password, you must also have a Cisco Services for IPS service contract before you can apply for a license key.

To obtain and install the license key, follow these steps:

- Step 1** Log in to IDM or IME using an account with administrator privileges.
- Step 2** For IDM choose **Configuration > Sensor Management > Licensing**. For IME choose **Configuration > sensor\_name > Sensor Management > Licensing**. The Licensing pane displays the status of the current license. If you have already installed your license, you can click **Download** to save it if needed.

- Step 3** Obtain a license key by doing one of the following:
- Click the **Cisco.com** radio button to obtain the license from Cisco.com. IDM or IME contacts the license server on Cisco.com and sends the server the serial number to obtain the license key. This is the default method. Go to Step 4.
  - Click the **License File** radio button to use a license file. To use this option, you must apply for a license key at this URL: [www.cisco.com/go/license](http://www.cisco.com/go/license). The license key is sent to you in e-mail and you save it to a drive that IDM or IME can access. This option is useful if your computer cannot access Cisco.com. Go to Step 7.
- Step 4** Click **Update License**, and in the Licensing dialog box, click **Yes** to continue. The Status dialog box informs you that the sensor is trying to connect to Cisco.com. An Information dialog box confirms that the license key has been updated.
- Step 5** Click **OK**.
- Step 6** Go to [www.cisco.com/go/license](http://www.cisco.com/go/license).
- Step 7** Fill in the required fields. Your license key will be sent to the e-mail address you specified.



---

**Caution** You must have the correct IPS device serial number because the license key only functions on the device with that number.

---

- Step 8** Save the license key to a hard-disk drive or a network drive that the client running IDM or IME can access.
- Step 9** Log in to IDM or IME.
- Step 10** For IDM choose **Configuration > Sensor Management > Licensing**. For IME choose **Configuration > sensor\_name > Sensor Management > Licensing**.
- Step 11** Under Update License, click the **License File** radio button.
- Step 12** In the Local File Path field, specify the path to the license file or click **Browse Local** to browse to the file.
- Step 13** Browse to the license file and click **Open**.
- Step 14** Click **Update License**.
- 

#### For More Information

For information on Cisco service contracts, see [Service Programs for IPS Products, page 20](#).

## Using the CLI

Use the **copy source-url license\_file\_name license-key** command to copy the license key to your sensor.

The following options apply:

- *source-url*—The location of the source file to be copied. It can be a URL or keyword.
- *destination-url*—The location of the destination file to be copied. It can be a URL or a keyword.
- **license-key**—The subscription license file.
- *license\_file\_name*—The name of the license file you receive.



#### Note

---

You cannot install an older license key over a newer license key.

---

The exact format of the source and destination URLs varies according to the file. Here are the valid types:

- **ftp:**—Source or destination URL for an FTP network server. The syntax for this prefix is:  
ftp:[//[username@] location]/relativeDirectory]/filename  
ftp:[//[username@]location]//absoluteDirectory]/filename
- **scp:**—Source or destination URL for the SCP network server. The syntax for this prefix is:  
scp:[//[username@] location]/relativeDirectory]/filename  
scp:[//[username@] location]//absoluteDirectory]/filename



**Note** If you use FTP or SCP protocol, you are prompted for a password. If you use SCP protocol, you must add the remote host to the SSH known hosts list.

- **http:**—Source URL for the web server. The syntax for this prefix is:  
http:[//[username@]location]/directory]/filename
- **https:**—Source URL for the web server. The syntax for this prefix is:  
https:[//[username@]location]/directory]/filename



**Note** If you use HTTPS protocol, the remote host must be a TLS trusted host.

### Installing the License Key

To install the license key, follow these steps:

- Step 1** Apply for the license key at this URL: [www.cisco.com/go/license](http://www.cisco.com/go/license).



**Note** In addition to a valid Cisco.com username and password, you must also have a Cisco Services for IPS service contract before you can apply for a license key.

- Step 2** Fill in the required fields. Your Cisco IPS Signature Subscription Service license key will be sent by e-mail to the e-mail address you specified.



**Note** You must have the correct IPS device serial number because the license key only functions on the device with that number.

- Step 3** Save the license key to a system that has a web server, FTP server, or SCP server.

- Step 4** Log in to the CLI using an account with administrator privileges.

- Step 5** Copy the license key to the sensor.

```
sensor# copy scp://user@10.89.147.3://tftpboot/dev.lic license-key
Password: *****
```

- Step 6** Verify the sensor is licensed.

```
sensor# show version
Application Partition:
```

```

Cisco Intrusion Prevention System, Version 6.2(1)E3

Host:
  Realm Keys          key1.0
Signature Definition:
  Signature Update    S391.0          2008-04-16
  Virus Update        V1.2            2005-11-24
OS Version:          2.4.30-IDS-smp-bigphys
Platform:            ASA-SSM-20
Serial Number:       P300000220
Sensor up-time is 3 days.
Using 1031888896 out of 2093682688 bytes of available memory (49% usage)
system is using 17.8M out of 29.0M bytes of available disk space (61% usage)
application-data is using 52.4M out of 166.6M bytes of available disk space (33% usage)
boot is using 37.8M out of 68.5M bytes of available disk space (58% usage)

MainApp      N-2007_JUN_19_16_45  (Release)  2007-06-19T17:10:20-0500  Running
AnalysisEngine N-2007_JUN_19_16_45  (Release)  2007-06-19T17:10:20-0500  Running
CLI          N-2007_JUN_19_16_45  (Release)  2007-06-19T17:10:20-0500

```

## Upgrade History:

```
IPS-K9-6.2-1-E3 15:36:05 UTC Thu Apr 24 2008
```

```
Recovery Partition Version 1.1 - 6.2(1)E3
```

```
Host Certificate Valid from: 25-Apr-2008 to 26-Apr-2010
```

```
sensor#
```

**Step 7** Copy your license key from a sensor to a server to keep a backup copy of the license.

```

sensor# copy license-key scp://user@10.89.147.3://tftpboot/dev.lic
Password: *****
sensor#

```

## Installing or Upgrading Cisco IME and Migrating Data Into IME

This section describes how to install and upgrade IME, and how to migrate data from IEV or a previous version of IME.

**Note**

You can use IME 6.2 or 7.0 to monitor 6.2(1)E3 sensors.

**Cisco IEV, Cisco IOS IPS, and CSM**

If you have a version of Cisco IPS Event Viewer installed, the Install wizard prompts you to remove it before installing IME.

IME event monitoring is also supported in IOS-IPS versions that support the Cisco IPS 5.x/6.x signature format. We recommend IOS-IPS 12.4(15)T4 if you intend to use IME to monitor an IOS IPS device.

Some of the new IME functionality including health monitoring is not supported.

**Caution**

Do not install IME on top of existing installations of CSM. You must uninstall CSM before installing IME. Do not install CSM on top of existing installations of IME.

**Installation Notes and Caveats**

Observe the following when installing or upgrading IME:

- You can install IME over all versions of IME but not over IEV. All alert database and user settings are preserved.
- IME detects previous versions of IEV and prompts you to manually remove the older version before installing IME or to install IME on another system. The installation program then stops.
- Make sure you close any open instances of IME before upgrading to a new version of IME.
- Disable any anti-virus or host-based intrusion detection software before beginning the installation, and close any open applications. The installer spawns a command shell application that may trigger your host-based detection software, which causes the installation to fail.
- You must be administrator to install IME.
- IME coexists with other instances of the MySQL database. If you have a MySQL database installed on your system, you do NOT have to uninstall it before installing IME.

**Installing or Upgrading IME**

To install IME, follow these steps:

- Step 1** From the Download Software site on Cisco.com, download the IME executable file to your computer, or start IDM in a browser window, and under Cisco IPS Manager Express, click **download** to install the IME executable file. IME-7.0.4.exe is an example of what the IME executable file might look like.
- Step 2** Double-click the executable file. The Cisco IPS Manager Express - InstallShield Wizard appears. You receive a warning if you have a previous version of Cisco IPS Event Viewer installed. Acknowledge the warning, and exit installation. Remove the older version of IEV, and then continue IME installation.
- Step 3** Click **Next** to start IME installation.
- Step 4** Accept the license agreement and click **Next**.
- Step 5** Click **Next** to choose the destination folder, click **Install** to install IME, and then click **Finish** to exit the wizard. The Cisco IME and Cisco IME Demo icons are now on your desktop.

**Note**

The first time you start IME, you are prompted to set up a password.

**Migrating IEV Data**

To migrate IEV 5.x events to IME, you must exit the installation and manually export the old events by using the IEV 5.x export function to move the data to local files. After installing IME, you can import these files to the new IME system.

**Note**

IME does not support import and migration functions for IEV 4.x.

To export event data from IEV 5.x to a local file:

- 
- Step 1** From IEV 5.x, choose **File > Database Administration > Export Database Tables**.
  - Step 2** Enter the file name and select the table(s).
  - Step 3** Click **OK**. The events in the selected table(s) are exported to the specified local file.
- 

#### Importing IEV Event Data In to IME

To import event data in to IME, follow these steps:

- 
- Step 1** From IME, choose **File > Import**.
  - Step 2** Select the file exported from IEV 5.x and click **Open**. The contents of the selected file are imported in to IME.
- 

#### For More Information

For more information about Cisco IME, refer to [Installing and Using Cisco Intrusion Prevention System Manager Express 6.2](#) or [Installing and Using Cisco Intrusion Prevention System Manager Express 7.0](#).

## Restrictions and Limitations

The following restrictions and limitations apply to Cisco IPS 6.2(1)E3 software and the products that run it:

- The AIP SSC-5 does not support virtualization, unretiring default retired signatures, creating custom signatures, adding signatures, cloning signatures, or anomaly detection.
- The AIP SSC-5 can take up to 20 minutes to come online when it reboots after the installation of a new system image. You must let the process complete before you can make configuration changes to the AIP SSC-5. If you try to modify and save configuration changes before the process is complete, you receive an error message.
- Anomaly detection does not support IPv6 traffic; only IPv4 traffic is directed to the anomaly detection processor.
- ICMP signature engines do not support ICMPv6, they are IPv4-specific, for example, the Traffic ICMP signature engine. ICMPv6 is covered by the Atomic IP Advanced signature engine.
- Rate limiting and blocking are not supported for IPv6 traffic. If a signature is configured with a block or rate limit event action and is triggered by IPv6 traffic, an alert is generated but the action is not carried out.
- IPv6 does not support the following event actions: Request Block Host, Request Block Connection, or Request Rate Limit.
- CSM and MARS do not support IPv6.
- The AIM IPS and the NME IPS do not support the IPv6 features, because the routers in which they are installed do not send them IPv6 data. IPv6 inspection may work on the IDSM2, but we do not officially support it. There is no support for IPv6 on the management (command and control) interface. With ASA 8.2(1), the AIP SSM and the AIP SSC-5 support IPv6 features.

- VACLs on Catalyst switches do not have IPv6 support. The most common method for copying traffic to a sensor configured in Promiscuous mode is to use VACL capture. If you want to have IPv6 support, you can use SPAN ports.
- The AIM IPS and the NME IPS do not support virtualization.
- When you reload the router, the AIM IPS and the NME IPS also reload. To ensure that there is no loss of data on the AIM IPS or the NME IPS, make sure you shut down the module using the **shutdown** command before you use the **reload** command to reboot the router.
- Do not deploy IOS IPS and the AIM IPS and the NME IPS at the same time.
- When the AIM IPS and the NME IPS are used with an IOS firewall, make sure SYN flood prevention is done by the IOS firewall.

The AIM IPS and the NME IPS and the IOS firewall complement abilities of each other to create security zones in the network and inspect traffic in those zones. Because the AIM IPS and the NME IPS and the IOS firewall operate independently, sometimes they are unaware of the activities of the other. In this situation, the IOS firewall is the best defense against a SYN flood attack.

- Cisco access routers only support one IDS/IPS per router.
- An IPS appliance can support both promiscuous and inline monitoring at the same time; however you must configure each physical interface in either promiscuous or inline mode. The sensor must contain at least two physical sensing interfaces to perform both promiscuous and inline monitoring. The exceptions to this are the AIP SSM-10, the AIP SSM-20, and the AIP SSM-40. The AIP SSM can support both promiscuous and inline monitoring on its single physical back plane interface inside the adaptive security appliance. The configuration on the main adaptive security appliance can be used to designate which packets/connections should be monitored by the AIP SSM as either promiscuous or inline.
- When deploying an IPS sensor monitoring two sides of a network device that does TCP sequence number randomization, we recommend using a virtual sensor for each side of the device.
- IDM does not support any non-English characters, such as the German umlaut or any other special language characters. If you enter such characters as a part of an object name through IDM, they are turned into something unrecognizable and you will not be able to delete or edit the resulting object through IDM or the CLI.

This is true for any string that is used by CLI as an identifier, for example, names of time periods, inspect maps, server and URL lists, and interfaces.

- You can only install eight IDSM2s per switch chassis.
- When SensorApp is reconfigured, there is a short period when SensorApp cannot respond to any queries. Wait a few minutes after reconfiguration is complete before querying SensorApp for additional information.
- IDM and IME launch MySDN from the last browser window you opened, which is the default setting for Windows. To change this default behavior, in Internet Explorer, choose **Tools > Internet Options**, and then click the **Advanced** tab. Scroll down and uncheck the **Reuse windows for launching shortcuts** check box.

#### For More Information

- For more information on interoperability between modules, refer to [Interoperability With Other IPS Modules](#).
- For more information about IPv6, switches, and lack of VACL capture, see [IPv6, Switches, and Lack of VACL Capture](#), page 6.

# Recovering the Password

For most IPS platforms, you can now recover the password on the sensor rather than using the service account or reimaging the sensor. This section describes how to recover the password for the various IPS platforms. It contains the following topics:

- [Understanding Password Recovery, page 28](#)
- [Recovering the Appliance Password, page 29](#)
- [Recovering the IDSM2 Password, page 30](#)
- [Password Recovery for the AIP SSM and the AIP SSC-5, page 31](#)
- [Recovering the AIM IPS Password, page 32](#)
- [Recovering the NME IPS Password, page 32](#)
- [Disabling Password Recovery, page 33](#)
- [Verifying the State of Password Recovery, page 34](#)
- [Troubleshooting Password Recovery, page 34](#)

## Understanding Password Recovery

Password recovery implementations vary according to IPS platform requirements. Password recovery is implemented only for the cisco administrative account and is enabled by default. The IPS administrator can then recover user passwords for other accounts using the CLI. The cisco user password reverts to **cisco** and must be changed after the next login.



**Note**

Administrators may need to disable the password recovery feature for security reasons.

[Table 4](#) lists the password recovery methods according to platform.

**Table 4 Password Recovery Methods According to Platform**

Platform	Description	Recovery Method
4200 series sensors	Standalone IPS appliances	GRUB prompt or ROMMON
AIP SSM AIP SSC-5	ASA 5500 series adaptive security appliance modules	Adaptive security appliance CLI command
IDSM2	Switch IPS module	Password recovery image file
AIM IPS NME IPS	Router IPS modules	Bootloader command

### For More Information

For more information on when and how to disable password recovery, see [Disabling Password Recovery, page 33](#).

## Recovering the Appliance Password

This section describes the two ways to recover the password for appliances. It contains the following topics:

- [Using the GRUB Menu, page 29](#)
- [Using ROMMON, page 29](#)

### Using the GRUB Menu

For 4200 series appliances, the password recovery is found in the GRUB menu, which appears during bootup. When the GRUB menu appears, press any key to pause the boot process.



#### Note

You must have a terminal server or direct serial connection to the appliance to use the GRUB menu to recover the password.

To recover the password on appliances, follow these steps:

**Step 1** Reboot the appliance.

The following menu appears:

```
GNU GRUB version 0.94 (632K lower / 523264K upper memory)
-----
0: Cisco IPS
1: Cisco IPS Recovery
2: Cisco IPS Clear Password (cisco)
-----
```

Use the ^ and v keys to select which entry is highlighted.  
Press enter to boot the selected OS, 'e' to edit the  
Commands before booting, or 'c' for a command-line.

Highlighted entry is 0:

**Step 2** Press any key to pause the boot process.

**Step 3** Choose **2: Cisco IPS Clear Password (cisco)**.

The password is reset to **cisco**. You can change the password the next time you log into the CLI.

#### For More Information

For more information on connecting an appliance to a terminal server, refer to [Connecting an Appliance to a Terminal Server](#).

### Using ROMMON

For the IPS 4240 and IPS 4255 you can use the ROMMON to recover the password. To access the ROMMON CLI, reboot the sensor from a terminal server or direct connection and interrupt the boot process.

To recover the password using the ROMMON CLI, follow these steps:

- 
- Step 1** Reboot the appliance.
- Step 2** To interrupt the boot process, press **ESC** or **Control-R** (terminal server) or send a **BREAK** command (direct connection).

The boot code either pauses for 10 seconds or displays something similar to one of the following:

- Evaluating boot options
- Use BREAK or ESC to interrupt boot

- Step 3** Enter the following commands to reset the password.

```
confreg 0x7
boot
```

#### Sample ROMMON session

```
Booting system, please wait...
CISCO SYSTEMS
Embedded BIOS Version 1.0(11)2 01/25/06 13:21:26.17
...
Evaluating BIOS Options...
Launch BIOS Extension to setup ROMMON
Cisco Systems ROMMON Version (1.0(11)2) #0: Thu Jan 26 10:43:08 PST 2006
Platform IPS-4240-K9
Use BREAK or ESC to interrupt boot.
Use SPACE to begin boot immediately.
Boot interrupted.
Management0/0
Link is UP
MAC Address:000b.fcfa.d155
Use ? for help.
rommon #0> confreg 0x7
Update Config Register (0x7) in NVRAM...
rommon #1> boot
```

---

## Recovering the IDSM2 Password

To recover the password for the IDSM2, you must install a special password recovery image file. This installation only resets the password, all other configuration remains intact. The password recovery image is version-dependent and can be found on the Cisco Download Software site. For IPS 6.x, download WS-SVC-IDSM2-K9-a-6.0-password-recovery.bin.gz. For IPS 7.x, download WS-SVC-IDSM2-K9-a-7.0-password-recovery.bin.gz.

FTP is the only supported protocol for image installations, so make sure you put the password recovery image file on an FTP server that is accessible to the switch. You must have administrative access to the Cisco 6500 series switch to recover the password on the IDSM2.

During the password recovery image installation, the following message appears:

```
Upgrading will wipe out the contents on the hard disk.
Do you want to proceed installing it [y|n]:
```

This message is in error. Installing the password recovery image does not remove any configuration, it only resets the login account.

Once you have downloaded the password recovery image file, follow the instructions to install the system image file but substitute the password recovery image file for the system image file. The IDSM2 should reboot in to the primary partition after installing the recovery image file. If it does not, enter the following command from the switch:

```
hw-module module module_number reset hdd:1
```

**Note**

The password is reset to **cisco**. Log in to the CLI with username **cisco** and password **cisco**. You can then change the password.

**For More Information**

- For the procedures for reimaging the IDSM2, refer to [Installing the IDSM2 System Image](#).
- For more information on downloading Cisco IPS software, see [Obtaining Software on Cisco.com](#), page 10.

## Password Recovery for the AIP SSM and the AIP SSC-5

You can reset the password to the default (**cisco**) for the AIP SSM and the AIP SSC-5 using the CLI or ASDM. Resetting the password causes the AIP SSM and the AIP SSC-5 to reboot. IPS services are not available during a reboot.

**Note**

To reset the password for the AIP SSM, you must have ASA 7.2.(2) or later. To reset the password for the AIP SSC-5, you must have ASA 8.2(1) or later.

Use the **hw-module module slot\_number password-reset** command to reset the password to the default **cisco**. The ASA 5500 series adaptive security appliance sets the ROMMON confreg bits to 0x7 and then reboots the sensor. The ROMMON bits cause the GRUB menu to default to option 2 (**reset password**).

If the module in the specified slot has an IPS version that does not support password recovery, the following error message is displayed:

```
ERROR: the module in slot <n> does not support password recovery.
```

**Using ASDM**

To reset the password in ASDM, follow these steps:

**Step 1** From the ASDM menu bar, choose **Tools > IPS Password Reset**.

**Note**

This option does not appear in the menu if there are no modules installed.

**Step 2** In the IPS Password Reset confirmation dialog box, click **OK** to reset the password to the default (**cisco**). A dialog box displays the success or failure of the password reset. If the reset fails, make sure you have ASA 7.2(2) or later on the adaptive security appliance and IPS 6.0 or later on the AIP SSM, and ASA 8.2(1) or later on the adaptive security appliance and IPS 6.2 or later on the AIP SSC-5.

**Step 3** Click **Close** to close the dialog box. the AIP SSM and the AIP SSC-5 reboot.

## Recovering the AIM IPS Password

To recover the password for the AIM IPS, use the **clear password** command. You must have console access to the AIM IPS and administrative access to the router.

To recover the password for the AIM IPS, follow these steps:

---

**Step 1** Log in to the router.

**Step 2** Enter privileged EXEC mode on the router.

```
router> enable
```

**Step 3** Confirm the module slot number in your router.

```
router# show run | include ids-sensor
interface IDS-Sensor0/0
router#
```

**Step 4** Session in to the AIM IPS.

```
router# service-module ids-sensor slot/port session
```

Example

```
router# service-module ids-sensor 0/0 session
```

**Step 5** Press **Control-shift-6** followed by **x** to navigate to the router CLI.

**Step 6** Reset the AIM IPS from the router console.

```
router# service-module ids-sensor 0/0 reset
```

**Step 7** Press **Enter** to return to the router console.

**Step 8** When prompted for boot options, enter **\*\*\*** quickly. You are now in the bootloader.

**Step 9** Clear the password.

```
ServicesEngine boot-loader# clear password
```

The AIM IPS reboots. The password is reset to **cisco**. Log in to the CLI with username **cisco** and password **cisco**. You can then change the password.

---

## Recovering the NME IPS Password

To recover the password for the NME IPS, use the **clear password** command. You must have console access to the NME IPS and administrative access to the router.

To recover the password for the NME IPS, follow these steps:

---

**Step 1** Log in to the router.

**Step 2** Enter privileged EXEC mode on the router.

```
router> enable
```

**Step 3** Confirm the module slot number in your router.

```
router# show run | include ids-sensor
interface IDS-Sensor1/0
router#
```

**Step 4** Session in to the NME IPS.

```
router# service-module ids-sensor slot/port session
```

Example

```
router# service-module ids-sensor 1/0 session
```

**Step 5** Press **Control-shift-6** followed by **x** to navigate to the router CLI.

**Step 6** Reset the NME IPS from the router console.

```
router# service-module ids-sensor 1/0 reset
```

**Step 7** Press **Enter** to return to the router console.

**Step 8** When prompted for boot options, enter **\*\*\*** quickly. You are now in the bootloader.

**Step 9** Clear the password.

```
ServicesEngine boot-loader# clear password
```

The NME IPS reboots. The password is reset to **cisco**. Log in to the CLI with username **cisco** and password **cisco**. You can then change the password.

## Disabling Password Recovery



### Caution

If you try to recover the password on a sensor on which password recovery is disabled, the process proceeds with no errors or warnings; however, the password is not reset. If you cannot log in to the sensor because you have forgotten the password, and password recovery is set to disabled, you must reimage your sensor.

Password recovery is enabled by default. You can disable password recovery through the CLI or IDM.

To disable password recovery in the CLI, follow these steps:

**Step 1** Log in to the CLI using an account with administrator privileges.

**Step 2** Enter global configuration mode.

```
sensor# configure terminal
```

**Step 3** Enter host mode.

```
sensor(config)# service host
```

**Step 4** Disable password recovery.

```
sensor(config-hos)# password-recovery disallowed
```

To disable password recovery in IDM, follow these steps:

- 
- Step 1** Log in to the CLI using an account with administrator privileges.
  - Step 2** Choose **Configuration > Sensor Setup > Network**. The Network pane appears.
  - Step 3** To disable password recovery, uncheck the **Allow Password Recovery** check box.
- 

#### For More Information

- If you are not certain about whether password recovery is enabled or disabled, see [Verifying the State of Password Recovery, page 34](#).
- For more information on reimaging sensors, refer to [Upgrading, Downgrading, and Installing System Images](#).

## Verifying the State of Password Recovery

Use the **show settings | include password** command to verify whether password recovery is enabled.

To verify whether password recovery is enabled, follow these steps:

- 
- Step 1** Log in to the CLI.
  - Step 2** Enter service host submode.
 

```
sensor# configure terminal
sensor (config)# service host
sensor (config-hos)#
```
  - Step 3** Verify the state of password recovery by using the **include** keyword to show settings in a filtered output.
 

```
sensor(config-hos)# show settings | include password
  password-recovery: allowed <defaulted>
sensor(config-hos)#
```
- 

## Troubleshooting Password Recovery

To troubleshoot password recovery, pay attention to the following:

- You cannot determine whether password recovery has been disabled in the sensor configuration from the ROMMON prompt, GRUB menu, switch CLI, or router CLI. If password recovery is attempted, it always appears to succeed. If it has been disabled, the password is not reset to **cisco**. The only option is to reimagine the sensor.
- You can disable password recovery in the host configuration. For the platforms that use external mechanisms, such as the AIMIPS and the NME IPS bootloader, ROMMON, and the maintenance partition for the IDSM2, although you can run commands to clear the password, if password recovery is disabled in the IPS, the IPS detects that password recovery is not allowed and rejects the external request.

To check the state of password recovery, use the **show settings | include password** command.

- When performing password recovery on the IDSM2, you see the following message: `Upgrading will wipe out the contents on the storage media. You can ignore this message. Only the password is reset when you use the specified password recovery image.`

#### For More Information

- For more information on reimaging sensors, refer to [Upgrading, Downgrading, and Installing System Images](#).
- For the procedure for disabling password recovery, see [Disabling Password Recovery, page 33](#).
- For the procedure for verifying the state of password recovery, see [Verifying the State of Password Recovery, page 34](#).

## Caveats

This section lists the resolved and known caveats, and contains the following topics:

- [Bug Toolkit, page 35](#)
- [Resolved Caveats, page 35](#)
- [Known Caveats, page 38](#)

## Bug Toolkit

Use the Bug Toolkit to search for known bugs based on software version, feature set, and keywords. The resulting matrix shows when each bug was integrated, or fixed if applicable. It also lets you save the results of a search in Bug Groups, and also create persistent Alert Agents that can feed those groups with new defect alerts.



#### Note

---

You must be logged in to Cisco.com to access the Bug Toolkit.

---

To access the Bug Toolkit, use this URL:

<http://tools.cisco.com/Support/BugToolKit/action.do?hdnAction=searchBugs>

## Resolved Caveats

The following known issues have been resolved in the 6.2(1) release:

- CSCsq94367—Multistring appears to be deleted twice
- CSCso09813—Missing victim context data in sig 5081
- CSCsq82903—Exact Match Offset Unintended behavior
- CSCsr04917—Signature 5565-4 Alerting twice
- CSCso31980—Fixed Engine "specify-service-ports" has a misleading guiName
- CSCsq94419—False Positive on 11022-1, 7202-0, and 11018.1
- CSCsq74297—SMB Advanced has infinite loop
- CSCsj18246—Event variables not tagged with the smallest locality

- CSCsr23555—IPS: zeroWindowProbe packets cause sequence number miscalculation
- CSCsr23025—IPS Signature 6967 E2 multi string not firing as package signature
- CSCsq97027—Abnormal Behavior in Engine MultiString
- CSCsm90428—String-tcp alert contains incorrect data in 'from target' context
- CSCso28141—Wrong attack context data captured
- CSCsq46856—H225 Engine Consumes Sensor Memory
- CSCsd19619—NO statistics on traffic under heavy load
- CSCsr81621—SensorApp core for 1315\_0\_ipv6.pcap in Proc6TcpTcb16dumpCurrentStateEv
- CSCsr74304—Virtual Sensor Stats Have No Service Granularity
- CSCsr84513—Fix aggressive mode transition logic
- CSCsr01778—Database shadow nodes contribute to decreased performance
- CSCso21050—Frequent error generation - SigEventList not empty
- CSCso76619—Bad frag/backlog handling causes excess dgram holding & missed 1st frags
- CSCsr49100—Signature 1102 false positive with E2 engine
- CSCsu05697—Improper calculation for triggering udp-length-mismatch
- CSCsu25729—Fixed-udp excluded ports parameter does not distinguish flow direction
- CSCsr94117—IOS and sensorApp do not process signatures the same way
- CSCsu36059—AIC HTTP Enforce Accept Content Types always enabled
- CSCso45473—Analysis Engine terminated prematurely
- CSCsr78743—InspectorAtomicL3L4 needs proper handling of IpHeaderLength param
- CSCsu42884—Repair HashTree::remove runtime fault
- CSCsu79570—Adjust default tcp-max-queue and BacklogQueue defaults
- CSCsu58580—Fixed-udp signatures perform double inspection
- CSCsu77935—4270 adds latency when under low load
- CSCsu95722—Signature validation in SMB Advanced should emit WARNING
- CSCsu74746—Error message starting SensorApp on backported engine
- CSCso96079—META alarms may have the wrong risk ratings
- CSCsr48923—Sig Update or Tuning causes abort in AtomicL3L4 Inspector ParmData logic
- CSCsv10964—Inline asymmetric mode not denying tcp resends
- CSCsj83029—CRAZYHAWK:sig 1308\_0 miscalculates checksums when modifying packets
- CSCsr29079—Quad GE NIC interface stops processing traffic
- CSCsu82973—XL driver not handling fragments properly
- CSCso49304—IPS - Large KB Thresholds represented as negatives
- CSCso85697—Certain traffic inline causes failure in updateProtocolState
- CSCsq03483—Kernel panic during sensor re-boot
- CSCsq20314—Show Version Upgrade History Timestamp Incorrect
- CSCsq22506—NAC throws error when shun list not empty on PIX at startup/reconnect
- CSCsq50873—Host stats causes invalid xml errors

- CSCsq87299—Cisco Autoupgrade errors need more detail
- CSCsr09502—ARC unable to rate limit on 2 or more interface/directions
- CSCsr07727—IPS 6.1.X Improper Signature Release Date
- CSCsr26125—Show tech output contains garbage characters
- CSCsr55036—IDSM-2 under promiscuous stress stopped responding
- CSCsi88201—Error message too cryptic for events with bad XML
- CSCsu24412—Cisco.com update leaves open https connection
- CSCsm48278—Invalid error message during upgrade scp command
- CSCsm70361—service external-product-interface config not carried forward on upgrade
- CSCsm72321—AIP module get stuck in high cpu due to mainApp infinite loop
- CSCsu90766—MainApp repeatedly logs warning: SensorApp status timed out

The following known issues have been resolved in the E3 engine release:

- CSCsq94367 —Multistring appears to be deleted twice
- CSCso09813—Missing victim context data in sig 5081
- CSCsq82903—Exact Match Offset Unintended behavior
- CSCsr04917—Signature 5565-4 Alerting twice
- CSCso31980—Fixed Engine "specify-service-ports" has a misleading guiName
- CSCsq94419—False Positive on 11022-1, 7202-0, and 11018.1
- CSCsq74297—SMB Advanced has infinite loop
- CSCsj18246 —Event variables not tagged with the smallest locality
- CSCsr23555—IPS: zeroWindowProbe packets cause sequence number miscalculation
- CSCsm90428—String-tcp alert contains incorrect data in 'from target' context
- CSCso28141—Wrong attack context data captured
- CSCsq46856—H225 Engine Consumes Sensor Memory
- CSCsd19619—NO statistics on traffic under heavy load
- CSCsr81621—SensorApp core for 1315\_0\_ipv6.pcap in Proc6TcpTcb16dumpCurrentStateEv
- CSCsr74304 —Virtual Sensor Stats Have No Service Granularity
- CSCsr84513—Fix aggressive mode transition logic
- CSCsr01778—Database shadow nodes contribute to decreased performance
- CSCso21050—Frequent error generation - SigEventList not empty
- CSCso76619—Bad frag/backlog handling causes excess dgram holding & missed 1st frags
- CSCsr49100—Signature 1102 false positive with E2 engine
- CSCsu05697—Improper calculation for triggering udp-length-mismatch
- CSCsr94117—IOS and sensorApp do not process signatures the same way
- CSCsu36059—AIC HTTP Enforce Accept Content Types always enabled
- CSCso45473—Analysis Engine terminated prematurely
- CSCsr78743—InspectorAtomicL3L4 needs proper handling of IpHeaderLength param
- CSCsu42884—Repair HashTree::remove runtime fault

- CSCsu79570—Adjust default tcp-max-queue and BacklogQueue defaults
- CSCsu58580—Fixed-udp signatures perform double inspection
- CSCsu77935—4270 adds latency when under low load
- CSCsu95722—Signature validation in SMB Advanced should emit WARNING
- CSCsu74746—Error message starting SensorApp on backported engine
- CSCso96079—META alarms may have the wrong risk ratings
- CSCsr48923—Sig Update or Tuning causes abort in AtomicL3L4 Inspector ParmData logic
- CSCsv10964—Inline asymmetric mode not denying tcp resends

The following known issues have been resolved for IDM in this release:

- CSCsm97366—Gettnng blank error message for custom sig creation
- CSCso07639—Main Help not working for Linux
- CSCso50942—Linux not reporting lost connection with sensor

## Known Caveats

The following known issues are found in Cisco IPS 6.2(1):

- CSCsg26929—Interface errors when enabled in cli and ifconfig up
- CSCsj40623—4260/4270 quad copper hw bypass has problems linking < 1000Mbps
- CSCsr02826—Missed Packet statistic does not work on AIM/NME
- CSCsv10548—SSM does not format backplane headers correctly in Promise
- CSCsg96871—AnalysisEngine InspectorServiceAICWeb::ToServiceInspect abort
- CSCsh45936—Leading Space in the uri-regex in Service-HTTP Works Ambiguously
- CSCsh89833—Delete event variable referenced by filter or sig from IDM
- CSCsi21029—GRE tunnels blocked by sensorApp inspection defect
- CSCsi60530—69xx firing but reporting wrong interface
- CSCsi73502—6.0(2)E1: No warning message when removing sensor used by ASA
- CSCsj14632—IP fragmented attacks through IPv4-in-IPv6 tunnel can be missed
- CSCsj35723—Sigs not alarming after default service sig sig0
- CSCsj57474—Frag traffic with dot1q headers misses a few sweep and atomic-ip sigs
- CSCsj70643—Normalizer signatures not modifying-packet-inline
- CSCsj82458—global-block-timeout allows values outside supported range
- CSCsl69776—AD is not generating an alert for every worm attacker
- CSCsm37654—Signature 1220.0 does not alarm
- CSCsm37826—Signature 1300 does not always alarm on a 4260
- CSCsm37943—Tcp Timeout Sigs do not produce alarms in promic
- CSCsm46158—Critical memory condition can cause race condition
- CSCsm47102—Signature 1308 does not function
- CSCso20750—modify-packet-inline computing incorrect checksum

- CSCso60709—Flood net Engine Sigs 69xx are not firing in promiscuous mode
- CSCso74628—AIM and NME underperforming in promiscuous mode
- CSCso98858—config change with bypass off triggers ASA failover
- CSCsq19704—meta sigs modified to replace meta-components only fire post restart
- CSCsu10359—Fragmented traffic may cause false negative
- CSCsu86596—Fixed UDP Engine does not properly handle start of packet ("^") in regex
- CSCsv01700—Analysis engine is down when Denied attackers are configured repeatedly
- CSCsv29654—Sig 5575 it is firing also for the return traffic
- CSCsh50760—NAC causes high mainApp usage
- CSCsl66235—Setup errors after defaulting sensor config via IDM
- CSCsl75224—cli command no mars-category causes sensor connection closed
- CSCsq18457—Unauthenticated Ntp settings lost after recover application-partition
- CSCsq53214—IPS reports different sig version in CT and CLI
- CSCsu48178—excessive https failures results in too many open files
- CSCsv26568—IPS SNMP InterfaceGroup OID does not show correct Virtual Sensor
- CSCsv28527—4260 shows incorrect available memory

The following known issues are found in the E3 engine release:

- CSCsg96871—AnalysisEngine InspectorServiceAICWeb::ToServiceInspect abort
- CSCsh45936—Leading Space in the uri-regex in Service-HTTP Works Ambiguously
- CSCsh89833—Delete event variable referenced by filter or sig from IDM
- CSCsi21029—GRE tunnels blocked by sensorApp inspection defect
- CSCsi60530—69xx firing but reporting wrong interface
- CSCsi73502—6.0(2)E1: No warning message when removing sensor used by ASA
- CSCsj14632—IP fragmented attacks through IPv4-in-IPv6 tunnel can be missed
- CSCsj35723—Sigs not alarming after default service sig sig0
- CSCsj57474—Frag traffic with dot1q headers misses a few sweep and atomic-ip sigs
- CSCsj70643—Normalizer signatures not modifying-packet-inline
- CSCsj82458—global-block-timeout allows values outside supported range
- CSCsl69776—AD is not generating an alert for every worm attacker
- CSCsm37654—Signature 1220.0 does not alarm
- CSCsm37826—Signature 1300 does not always alarm on a 4260
- CSCsm37943—Tcp Timeout Sigs do not produce alarms in promic
- CSCsm46158—Critical memory condition can cause race condition
- CSCsm47102—Signature 1308 does not function
- CSCso20750—modify-packet-inline computing incorrect checksum
- CSCso60709—Flood net Engine Sigs 69xx are not firing in promiscuous mode
- CSCso74628—AIM and NME underperforming in promiscuous mode
- CSCso98858—config change with bypass off triggers ASA failover

- CSCsq19704—meta sigs modified to replace meta-components only fire post restart
- CSCsu10359—Fragmented traffic may cause false negative
- CSCsu86596—Fixed UDP Engine does not properly handle start of packet ("^") in regex
- CSCsv01700—Analysis engine is down when Denied attackers are configured repeatedly
- CSCsv29654—Sig 5575 it is firing also for the return traffic

The following known issues are found in IDM 6.2(1)E3:

- CSCso96654—Editing EventActionRules removes all like Sig Actions
- CSCsq89977—IDM unable to edit multistring sig regex list entry
- CSCsr82134—IDM is allowing user to delete Risk Category that is in use
- CSCsu08058—Signatures Restore Default makes no changes if modified
- CSCsu21774—Better handling needed for Signature editing
- CSCsu47761—creating advanced atomic sig. results in blank main screen
- CSCsu93404—Unable to install a Trial License from CCO

The following known issue for the AIP SSC-5 is found in this release:

- CSCsy93548—SSC goes unresponsive after IPS image is applied

## Related Documentation

For more information on Cisco IPS 6.2(1)E3, refer to the following documentation found at this URL:

[http://www.cisco.com/en/US/products/hw/vpndevc/ps4077/tsd\\_products\\_support\\_series\\_home.html](http://www.cisco.com/en/US/products/hw/vpndevc/ps4077/tsd_products_support_series_home.html)

- *Documentation Roadmap for Cisco Intrusion Prevention System 6.2*
- *Installing and Using Cisco Intrusion Prevention System Device Manager 6.2*
- *Installing and Using Cisco Intrusion Prevention System Manager Express 6.2*
- *Cisco Intrusion Prevention System Command Reference 6.2*
- *Configuring the Cisco Intrusion Prevention System Sensor Using the Command Line Interface 6.2*
- *Installing Cisco Intrusion Prevention System Appliances and Modules*
- *Installing and Removing Interface Cards in Cisco IPS-4260 and IPS 4270-20*
- *Regulatory Compliance and Safety Information for the Cisco Intrusion Prevention System 4200 Series Appliance Sensor*

## Obtaining Documentation and Submitting a Service Request

For information on obtaining documentation, submitting a service request, and gathering additional information, see the monthly *What's New in Cisco Product Documentation*, which also lists all new and revised Cisco technical documentation, at:

<http://www.cisco.com/en/US/docs/general/whatsnew/whatsnew.html>

Subscribe to the *What's New in Cisco Product Documentation* as a Really Simple Syndication (RSS) feed and set content to be delivered directly to your desktop using a reader application. The RSS feeds are a free service and Cisco currently supports RSS Version 2.0.

---

This document is to be used in conjunction with the documents listed in the “[Related Documentation](#)” section.

Cisco and the Cisco Logo are trademarks of Cisco Systems, Inc. and/or its affiliates in the U.S. and other countries. A listing of Cisco's trademarks can be found at [www.cisco.com/go/trademarks](http://www.cisco.com/go/trademarks). Third party trademarks mentioned are the property of their respective owners. The use of the word partner does not imply a partnership relationship between Cisco and any other company. (1005R)

Copyright © 2009-2011 Cisco Systems, Inc. All rights reserved.

