



CHAPTER 10

Installing NM-CIDS

**Note**

The number of concurrent CLI sessions is limited based on the platform. IDS-4215 and NM-CIDS are limited to three concurrent CLI sessions. All other platforms allow ten concurrent sessions.

**Note**

In Cisco IOS documentation, NM-CIDS is referred to as the Cisco IDS network module.

**Note**

NM-CIDS does not support inline (IPS) mode. It can only be configured for promiscuous (IDS) mode.

**Caution**

Although NM-CIDS has a compact flash slot, a compact flash device is not used. Removing the compact flash cover and installing a compact flash device is not supported. NM-CIDS does not operate with a compact flash device installed.

This chapter lists the software and hardware requirements of NM-CIDS, and describes how to install and remove it. It contains the following sections:

- [Specifications, page 10-2](#)
- [Software and Hardware Requirements, page 10-2](#)
- [Hardware Architecture, page 10-3](#)
- [Front Panel Features, page 10-4](#)
- [Interfaces, page 10-5](#)
- [Installation and Removal Instructions, page 10-5](#)

Specifications

Table 10-1 lists the specifications for NM-CIDS.

Table 10-1 NM-CIDS Specifications

Specification	Description
Dimensions (H x W x D)	1.55 x 7.10 x 7.2 in. (3.9 x 18.0 x 19.3 cm)
Weight	1.5 lb (0.7 kg) (maximum)
Operating temperature	+32° to +104°F (+0° to +40°C)
Nonoperating temperature	−40° to +185°F (−40° to +85°C)
Humidity	5% to 95% noncondensing
Operating altitude	0 to 10,000 ft (0 to 3,000 m)

Software and Hardware Requirements

NM-CIDS has the following software and hardware requirements.

NM-CIDS supports the following software:

- Cisco IOS software 12.2(15)ZJ or later
- Cisco IOS software 12.3(4)T or later
- Cisco IDS software 4.1 or later



Caution

Do not confuse Cisco IOS IDS (a software-based intrusion-detection application that runs in the Cisco IOS) with the IDS that runs on NM-CIDS. NM-CIDS runs Cisco IPS 5.1. Because performance can be reduced and duplicate alarms can be generated, we recommend that you do not run Cisco IOS IDS and Cisco IPS 51 simultaneously.

NM-CIDS supports the following feature sets:

- IOS IP/FW/IDS
- IOS IP/FW/IDS PLUS IPSEC 56
- IOS IP/FW/IDS PLUS IPSEC 3DES
- IOS IP/IPX/AT/DEC/FW/IDS PLUS
- IOS ENTERPRISE/FW/IDS PLUS IPSEC 56
- IOS ENTERPRISE/FW/IDS PLUS IPSEC 3DES
- IOS Advanced Security
- IOS Advanced IP
- IOS Advanced Enterprise

Table 10-2 lists supported and unsupported platforms for NM-CIDS.

Table 10-2 Supported and Unsupported Platforms

Router	NM-CIDS
Cisco 2600 series	No
Cisco 2600XM series	Yes
Cisco 2691	Yes
Cisco 3620	No
Cisco 3631	No
Cisco 3640, Cisco 3640A	No
Cisco 3660	Yes
Cisco 3725	Yes
Cisco 3745	Yes



Note

The supported Cisco series routers only support one NM-CIDS per chassis.

Table 10-3 lists the hardware specifications for NM-CIDS.

Table 10-3 Hardware Requirements

Feature	Description
Processor	500 Mhz Intel Mobile Pentium III
Default SDRAM	512 MB
Maximum DSRAM	512 MB
Internal disk storage	NM-CIDS 20-GB IDE

Hardware Architecture

NM-CIDS has the following hardware architecture:

- Back-to-back Ethernet, which provides interface-level connectivity to the router.
- 100-Mbps full-duplex interface between the router and the module.
- Back-to-back UART, which provides console access from router side.
- Console access to the module from the router.
- External FE interface, which provides a command and control interface.

Figure 10-1 shows the hardware architecture of NM-CIDS.

Figure 10-1 NM-CIDS Hardware Architecture

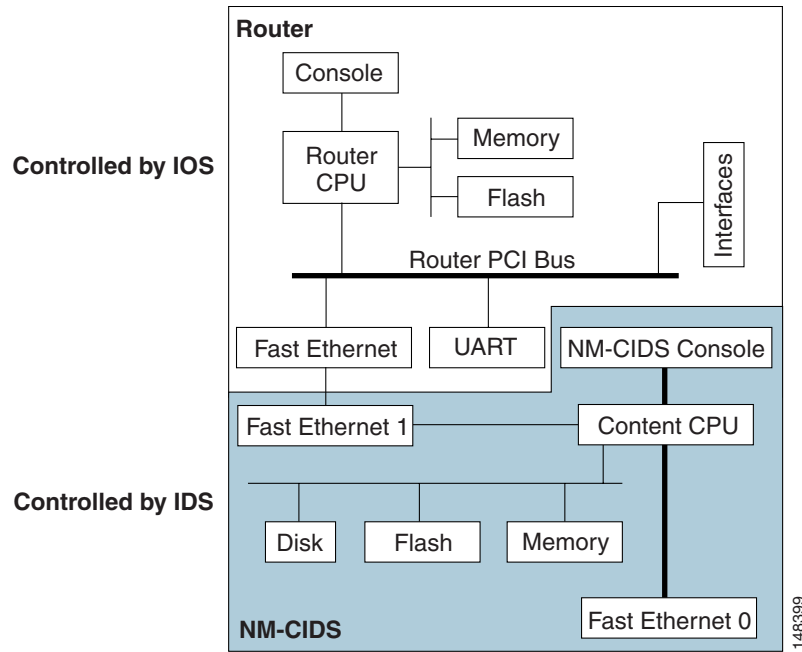

Front Panel Features

Figure 10-2 shows the front panel features of the NM-CIDS.

Figure 10-2 Front Panel Features

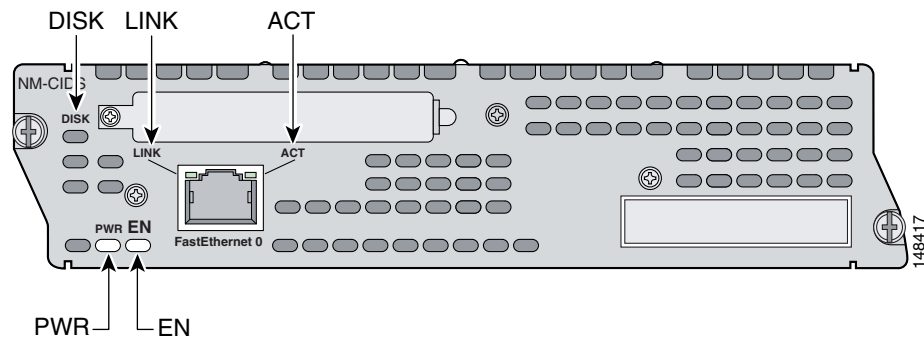

Table 10-4 describes the NM-CIDS states as indicated by the status indicators.

Table 10-4 Status Indicators

Indicator	Description
ACT	Activity on the fast ethernet connection.
DISK	Activity on the IDS hard-disk drive.
EN	NM-CIDS has passed self-test and is available to the router.
LINK	Fast Ethernet connection is available to NM-CIDS.
PWR	Power is available to NM-CIDS.

Interfaces

The router-side fast ethernet interface is known as “interface IDS-Sensor.” This interface name appears in the **show interface** and **show controller** commands. You must assign the IP address to the interface to get console access to IDS.



Caution

We recommend that you assign a loopback address on the monitoring interface, otherwise if the IP address is advertised through routing updates, the monitoring interface can become vulnerable to attacks.

For More Information

For the procedure for assigning the IP address to gain access to the console and for setting up a loopback address, refer to [Configuring IDS-Interfaces on the Router](#).

Installation and Removal Instructions

You must install NM-CIDS offline in Cisco 2650XM, 2651XM, and 2961 series routers.



Caution

To avoid damaging NM-CIDS, you must turn OFF electrical power and disconnect network cables before you insert NM-CIDS into a chassis slot or remove NM-CIDS from a chassis slot.

Cisco 3660 and Cisco 3700 series routers lets you replace network modules without switching off the router or affecting the operation of other interfaces. OIR provides uninterrupted operation to network users, maintains routing information, and ensures session preservation.



Note

Cisco 2600, 3600, and 3700 series routers support only one NM-CIDS per chassis.



Caution

Unlike other network modules, NM-CIDS uses a hard-disk drive. Online removal of hard-disk drives without proper shutdown can result in file system corruption and might render the hard-disk drive unusable. The operating system on NM-CIDS must be shut down in an orderly fashion before it is removed.

This section contains the following topics:

- [Required Tools, page 10-6](#)
- [Installing NM-CIDS, page 10-6](#)
- [Removing NM-CIDS, page 10-9](#)
- [Blank Network Module Panels, page 10-12](#)

Required Tools

You need the following tools and equipment to install NM-CIDS in a Cisco modular router chassis slot:

- #1 Phillips screwdriver or small flat-blade screwdriver
- ESD-preventive wrist strap
- Tape for DC circuit breaker handle

Installing NM-CIDS

This section describes how to install NM-CIDS off line and using OIR support, and contains the following topics:

- [Installing NM-CIDS Offline, page 10-6](#)
- [Installing NM-CIDS Using OIR Support, page 10-8](#)

Installing NM-CIDS Offline

You can install NM-CIDS in the chassis either before or after mounting the router, whichever is more convenient.



Warning

Only trained and qualified personnel should be allowed to install or replace this equipment. To see translations of the warnings that appear in this publication, refer to the Regulatory Compliance and Safety Information document that accompanied this device.



Caution

ESD can damage equipment and impair electrical circuitry. Always follow ESD prevention procedures when removing and replacing cards.

To install NM-CIDS, follow these steps:

-
- Step 1** Turn OFF electrical power to the router.
To channel ESD voltages to ground, do not unplug the power cable.
 - Step 2** Remove all network interface cables, including telephone cables, from the back panel.

The following warning applies to routers that use a DC power supply:



Warning

Before performing any of the following procedures, ensure that power is removed from the DC circuit. To ensure that all power is OFF, locate the circuit breaker on the panel board that services the DC circuit, switch the circuit breaker to the OFF position, and tape the switch handle of the circuit breaker in the OFF position.

- Step 3** Using either a #1 Phillips screwdriver or a small flat-blade screwdriver, remove the blank filler panel from the chassis slot where you plan to install NM-CIDS.
Save the blank panel for future use.
- Step 4** Align NM-CIDS with the guides in the chassis and slide it gently into the slot.

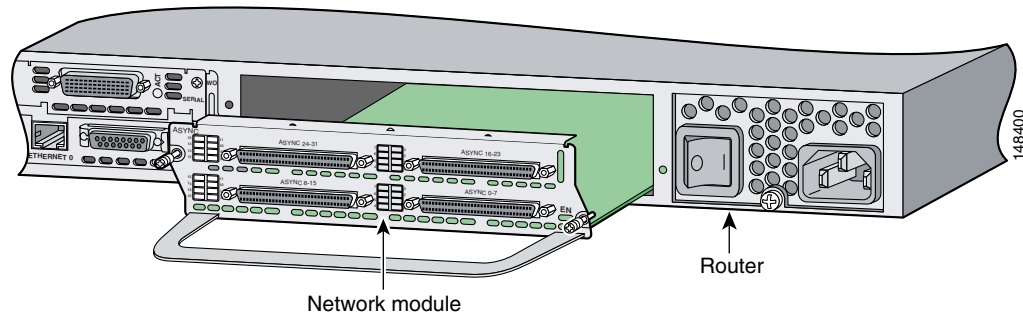

- Step 5** Push NM-CIDS into place until you feel its edge connector mate securely with the connector on the motherboard.
- Step 6** Fasten the captive mounting screws of NM-CIDS into the holes in the chassis, using a Phillips or flat-blade screwdriver.
- Step 7** If the router was previously running, reinstall the network interface cables and turn ON power to the router.

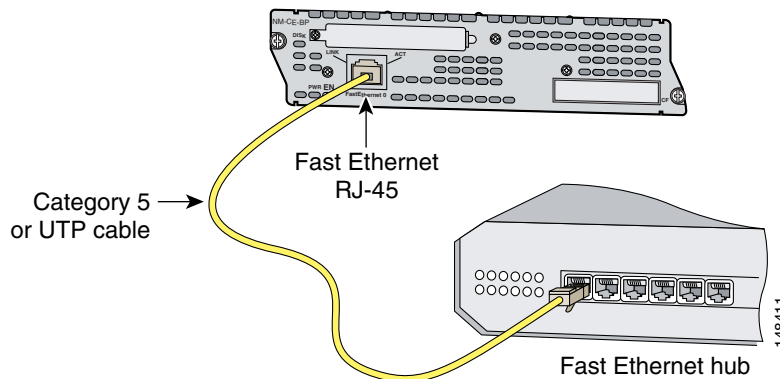

The following warning applies to routers that use a DC power supply:



Warning

After wiring the DC power supply, remove the tape from the circuit breaker switch handle and reinstate power by moving the handle of the circuit breaker to the ON position.

- Step 8** Connect the command and control port to a hub or switch.

- Step 9** Check that NM-CIDS indicators light up, and that the Active/Ready indicators on the front panel also light up.
- Step 10** Initialize NM-CIDS.
- Step 11** Upgrade NM-CIDS to the most recent Cisco software.
You are now ready to configure intrusion detection on NM-CIDS.

For More Information

- For more information on ESD-controlled environments, see [Site and Safety Guidelines](#), page 1-30.
- For the procedure for using the **setup** command to initialize NM-CIDS, see [Initializing NM-CIDS](#), page 11-32.
- For the procedure for obtaining the latest IPS software, see [Obtaining Cisco IPS Software](#), page 13-1.
- For the procedure for using HTTPS to log in to IDM, refer to [Logging In to IDM](#).
- For the procedures for configuring intrusion prevention on your sensor, refer to the following documents:
 - [Installing and Using Cisco Intrusion Prevention System Device Manager 6.0](#)
 - [Configuring the Cisco Intrusion Prevention System Sensor Using the Command Line Interface 6.0](#)

Installing NM-CIDS Using OIR Support

To install NM-CIDS using OIR support, follow these steps:

- Step 1** Align NM-CIDS with the guides in the chassis slot and slide it gently into the slot.

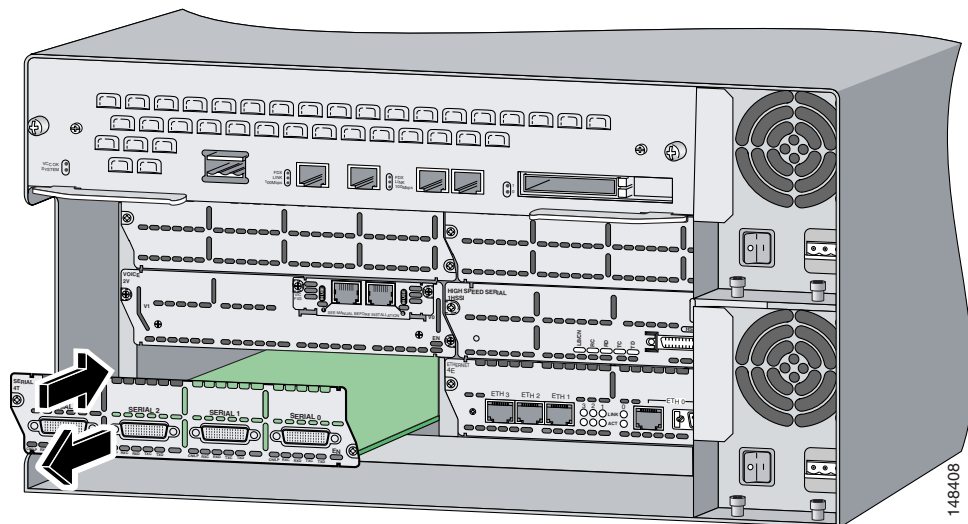

- Step 2** Push NM-CIDS into place until you feel its edge connector mate securely with the connector on the backplane.
- Step 3** Tighten the two captive screws on the faceplate.

Step 4 Connect the command and control port to a hub or switch.

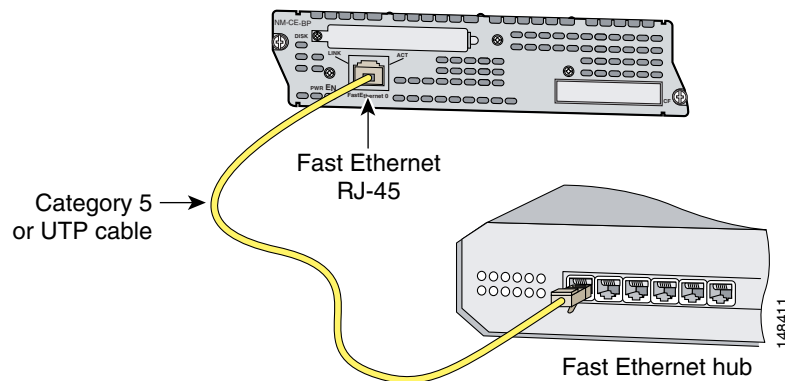

Step 5 Verify that NM-CIDS indicators light up, and that the Active/Ready indicators on the front panel also light up.

Step 6 Initialize NM-CIDS.

Step 7 Upgrade NM-CIDS to the most recent Cisco IPS software.

You are now ready to configure intrusion detection on NM-CIDS.

For More Information

- For the procedure for using the **setup** command to initialize NM-CIDS, see [Initializing NM-CIDS, page 11-32](#).
- For the procedure for obtaining the latest IPS software, see [Obtaining Cisco IPS Software, page 13-1](#).
- For the procedure for using HTTPS to log in to IDM, refer to [Logging In to IDM](#).
- For the procedures for configuring intrusion prevention on your sensor, refer to the following documents:
 - [Installing and Using Cisco Intrusion Prevention System Device Manager 6.0](#)
 - [Configuring the Cisco Intrusion Prevention System Sensor Using the Command Line Interface 6.0](#)

Removing NM-CIDS

This section describes how to remove NM-CIDS offline or using OIR support, and contains the following topics:

- [Removing NM-CIDS Offline, page 10-10](#)
- [Removing NM-CIDS Using OIR Support, page 10-10](#)

Removing NM-CIDS Offline

You must turn off all power to the router before removing NM-CIDS.

To remove NM-CIDS from the router chassis, follow these steps:

Step 1 Prepare NM-CIDS to be powered off:

```
router# service-module IDS-Sensor slot_number/0 shutdown
Trying 10.10.10.1, 2129 ... Open
```

Wait for the shutdown message before continuing with Step 2:

```
%SERVICEMODULE-5-SHUTDOWN2:Service module IDS-Sensor1/0 shutdown complete
```

Step 2 Turn OFF electrical power to the router.

To channel ESD voltages to ground, do not unplug the power cable.

Step 3 Unplug the command and control network interface cable from NM-CIDS.

Step 4 Loosen the two captive screws holding NM-CIDS in the chassis slot.

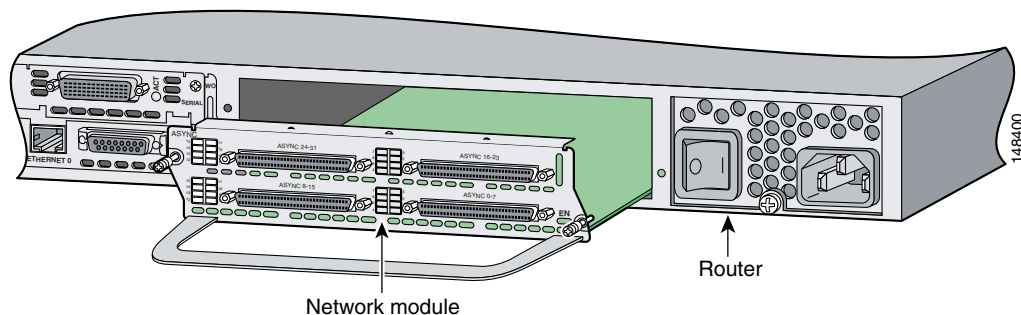

Step 5 Slide NM-CIDS out of the slot.



Note Either install a replacement NM-CIDS or install a blank panel.

For More Information

- For the procedure for installing replacement NM-CIDS, see [Installing NM-CIDS Offline, page 10-6](#).
- For the procedure for installing a blank panel, see [Blank Network Module Panels, page 10-12](#).

Removing NM-CIDS Using OIR Support



Caution

Cisco 3660 and Cisco 3700 series routers support OIR with similar modules only. If you remove an NM-CIDS, install another NM-CIDS in its place.

To remove NM-CIDS with OIR support, follow these steps:

Step 1 Prepare NM-CIDS to be powered off:

```
router# service-module IDS-Sensor slot_number/0 shutdown
Trying 10.10.10.1, 2129 ... Open
```

Wait for the shutdown message before continuing with Step 2:

```
%SERVICEMODULE-5-SHUTDOWN2:Service module IDS-Sensor1/0 shutdown complete
```

Step 2 Unplug the command and control network interface cable from NM-CIDS.

Step 3 Loosen the two captive screws holding NM-CIDS in the chassis slot.

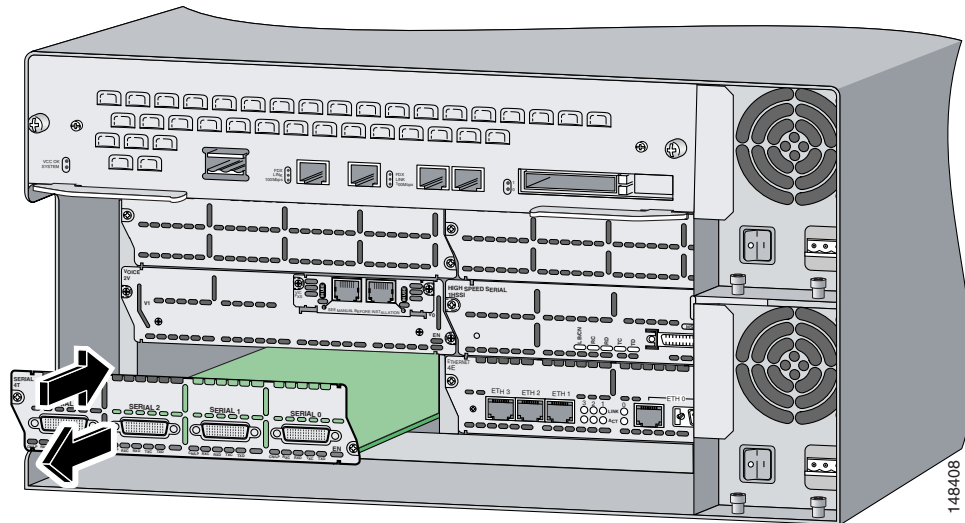

Step 4 Slide NM-CIDS out of the slot.



Note Either install a replacement NM-CIDS or install a blank panel.

For More Information

- For the procedure for installing replacement NM-CIDS, see [Installing NM-CIDS Offline](#), page 10-6.
- For the procedure for installing a blank panel, see [Blank Network Module Panels](#), page 10-12.

Blank Network Module Panels

If the router is not fully configured with network modules, make sure that blank panels fill the unoccupied chassis slots to provide proper airflow as shown in [Figure 10-3](#).

Figure 10-3 Blank Network Module Panel

