



Upgrading Memory in Cisco 800 Series Routers

This document describes how to upgrade flash memory and dynamic RAM (DRAM) for the Cisco 800 series routers:

- | | |
|-------------------------|---------------------|
| • Cisco 801–804 routers | • Cisco 836 routers |
| • Cisco 805 routers | • Cisco 837 routers |
| • Cisco 806 routers | • Cisco 851 routers |
| • Cisco 811–813 routers | • Cisco 857 routers |
| • Cisco 826 routers | • Cisco 871 routers |
| • Cisco 827 routers | • Cisco 876 routers |
| • Cisco 828 routers | • Cisco 877 routers |
| • Cisco 831 routers | • Cisco 878 routers |



Note

The memory on the Cisco SOHO routers cannot be upgraded.



Note

To upgrade memory in Cisco 880 series routers, see the [Installing Memory and Power Over Ethernet in Cisco 880 Series Integrated Services Routers](#) document at:
<http://www.cisco.com/en/US/docs/routers/access/800/860-880-890/hardware/installation/memory/880FRU.html>

Organization

The following sections are included in this document:

- [Warning and Safety Information](#)
- [Opening the Chassis](#)
- [Upgrading the Flash Memory](#)
- [Upgrading the DRAM](#)



Americas Headquarters:

Cisco Systems, Inc., 170 West Tasman Drive, San Jose, CA 95134-1706 USA

- [Closing the Chassis](#)

Warning and Safety Information

To see translations of the warnings that appear in this publication, refer to the *Regulatory Compliance and Safety Information* (RCSI) document that accompanied your Cisco router. The following warning information is included in the RCSI:



Warning

Only trained and qualified personnel should be allowed to install, replace, or service this equipment. Statement 1030



Warning

During this procedure, wear grounding wrist straps to avoid ESD damage to the card. Do not directly touch the backplane with your hand or any metal tool, or you could shock yourself. Statement 94

Opening the Chassis

To upgrade the flash memory and dynamic RAM (DRAM), you must open the router chassis. You must provide a number 1 Phillips screwdriver and an antistatic mat.

The model shown in the following procedure is a Cisco 804 router, but the other Cisco 800 series routers are similar to it. Follow these steps to open the chassis:

- Step 1** Make sure that the power switch is turned to standby and that the power supply cable is disconnected.
- Step 2** Disconnect all cables from the router back panel.
- Step 3** Use the Phillips screwdriver to remove the two screws. [Figure 1](#) shows the chassis screw locations. The chassis screw locations are the same on all Cisco 800 series routers.

Figure 1 Removing the Chassis Screws

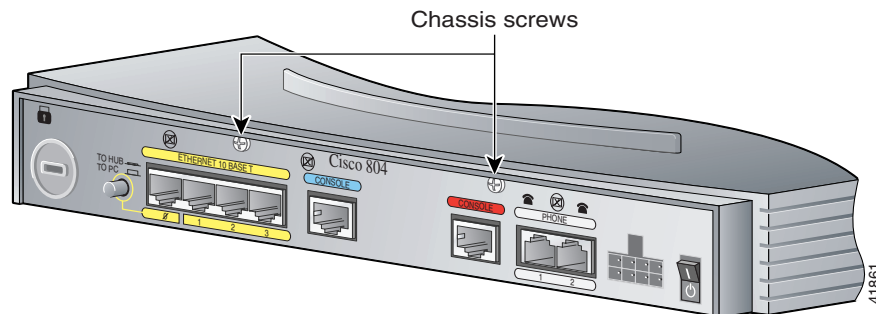

- Step 4** Gently push the top of the router away from you and then lift it up from the bottom of the router.
- Step 5** Place the router bottom on an antistatic mat.

Upgrading the Flash Memory

This section describes how to upgrade the flash memory in a Cisco 800 series router.



Note

The Cisco SOHO series routers do not support flash and StrataFlash memory upgrade.

Table 1 shows the flash memory options for each Cisco 800 series router platform.

Table 1 Flash Memory Options

Platform	Flash Memory Card Options	Default Flash Memory	Maximum Flash Memory
Cisco 801–804 routers	4 MB or 8 MB	8 MB (4 MB of onboard flash memory and a 4-MB flash memory card)	12 MB
Cisco 805 routers	4 MB or 8 MB	8 MB (4 MB of onboard flash memory and a 4-MB flash memory card)	12 MB
Cisco 806 routers	8 MB	8 MB (onboard flash only)	16 MB
Cisco 811–813 routers	4 MB or 8 MB	8 MB (4 MB of onboard flash memory and a 4-MB flash memory card)	12 MB
Cisco 826, 827, and 828 routers	4 MB or 8 MB	8 MB (onboard flash only)	16 MB
Cisco 827-4V routers	4 MB or 8 MB	12 MB (8 MB onboard flash memory and 4-MB flash memory card)	16 MB
Cisco 831, 836, and 837 routers	4 MB, 8 MB, or 16 MB	12 MB (8 MB onboard flash memory and a 4-MB flash memory card)	24 MB

Table 1 Flash Memory Options (continued)

Platform	Flash Memory Card Options	Default Flash Memory	Maximum Flash Memory
Cisco 851 and 857 routers	4 MB, 16 MB, or 32 MB	20 MB (onboard flash memory only)	20 MB
Cisco 871, 876, 877, and 878 routers	4 MB, 16 MB, or 32 MB	24 MB (20 MB of onboard flash memory and a 4-MB flash memory card)	52 MB

You can order upgrade kits and have trained and qualified personnel add the flash memory.

Table 2 identifies the flash memory upgrade kits available for the Cisco 801–806, 811–813, and 826–828 routers.

Table 2 Flash Memory Upgrade Kits for Cisco 801–806, 811–813, and 826–828 Routers

Description	Cisco Part Number
4-MB flash memory module	MEM800-4F=
8-MB flash memory module	MEM800-8F=

Table 4 identifies the flash memory upgrade kits available for the Cisco 831, 836, and 837 routers.

Table 3 Flash Memory Upgrade Kits for Cisco 831, 836, and 837 Routers

Description	Cisco Part Number
4-MB flash memory module	MEM830-4F=
8-MB flash memory module	MEM830-8F=
16-MB flash memory module	MEM830-16F=

Table 4 identifies the flash memory upgrade kits available for the Cisco 871, 876, 877, 878 routers.

Table 4 Flash Memory Upgrade Kits for Cisco 871, 876, 877, 878 Routers

Description	Cisco Part Number
4-MB flash memory module	MEM870-4F=
8-MB flash memory module	MEM870-8F=
16-MB flash memory module	MEM870-16F=
32-MB flash memory module	MEM870-32F=

Locating the Flash Memory Slot

Figure 2 shows where the flash memory module can be installed on the router motherboard. The flash memory slot location is similar on all Cisco 800 series routers. The connector type may vary for some Cisco 800 series routers and will look slightly different from the one illustrated below.

Figure 2 Location of Flash Memory Slot

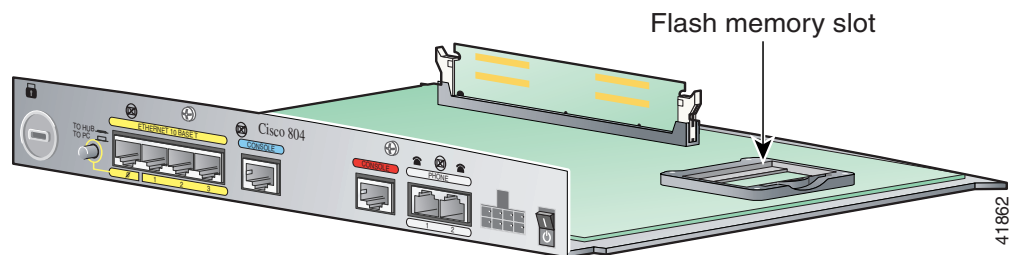

Locating the StrataFlash Memory Slot

Figure 3 shows where the StrataFlash memory module can be installed on the router motherboard. The StrataFlash memory slot location is similar on all Cisco 800 series routers. The orientation of the connector may vary for some Cisco 800 series routers, with the opening turned inward instead of outward as illustrated below.

Figure 3 Location of StrataFlash Memory Slot

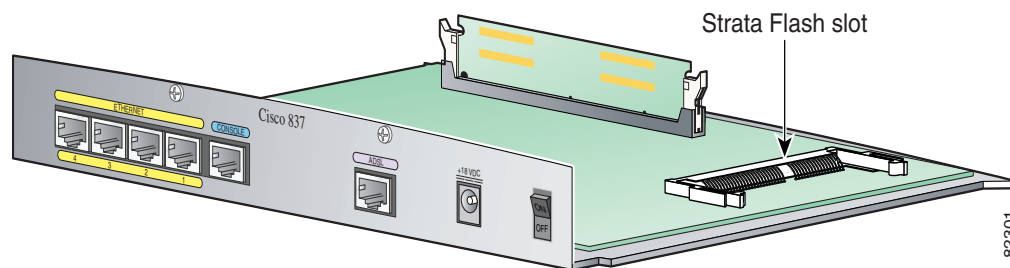

Installing Flash Memory

To upgrade the flash memory, you must install a mini-flash memory module on the router motherboard, as shown in Figure 4.

Figure 4 *Mini-Flash Memory Module*

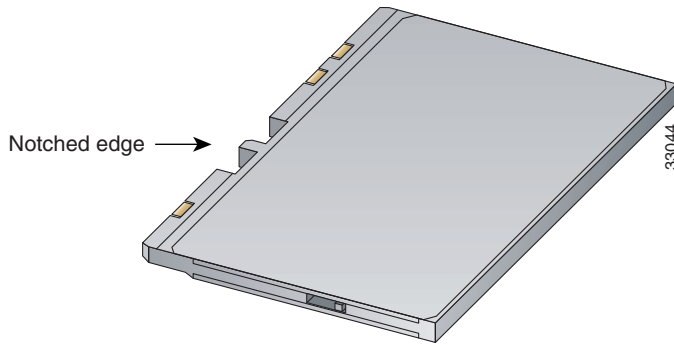

Installing StrataFlash Memory

To upgrade the StrataFlash memory, you must install a StrataFlash memory module on the router motherboard, as shown in [Figure 5](#).

Figure 5 *StrataFlash Memory Module*

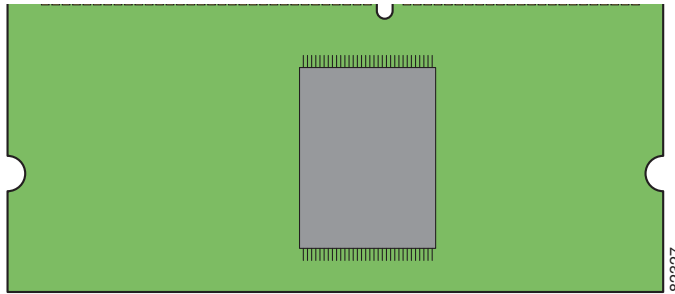

Installing a Mini-Flash Memory Module

Follow these steps to install a mini-flash memory module:

-
- Step 1** Insert the notched edge of the module into the slot at an angle, as shown in [Figure 6](#).

Figure 6 *Installing a Mini-Flash Memory Module*

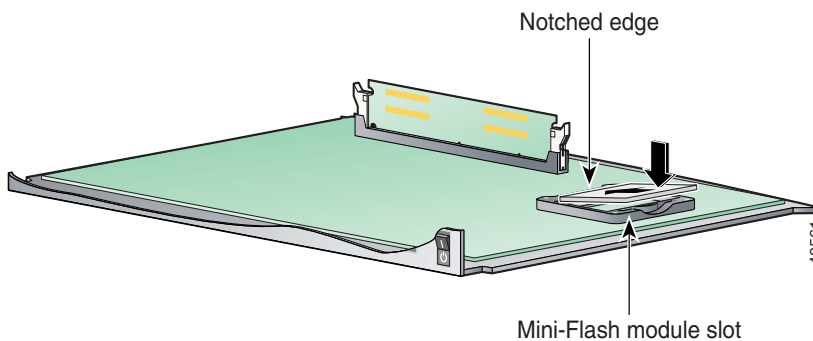

- Step 2** Firmly press down the unnotched edge of the module until you hear a click.

Removing a Mini-Flash Memory Module

Follow these steps to remove a mini-flash memory module:

- Step 1** Put your finger on the mini-flash module release lever and push up. See [Figure 7](#).

Figure 7 Removing a Mini-Flash Module

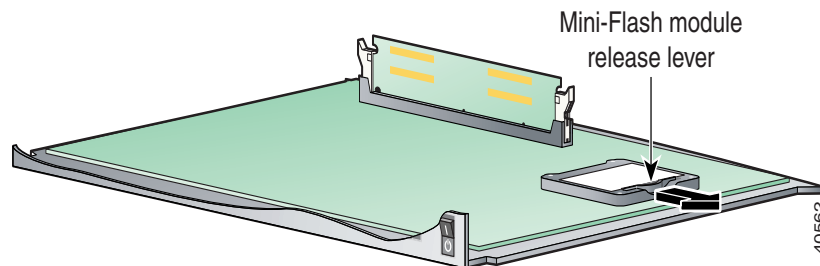

- Step 2** Firmly pull the release lever away from the module until the module pops up and away from the module slot.

Installing a StrataFlash Memory Module

Follow these steps to install a StrataFlash memory module:

- Step 1** Insert the notched edge of the module into the slot at an angle, as shown in [Figure 8](#). Make sure the module is fully seated and makes good contact.

Figure 8 Installing a StrataFlash Memory Module

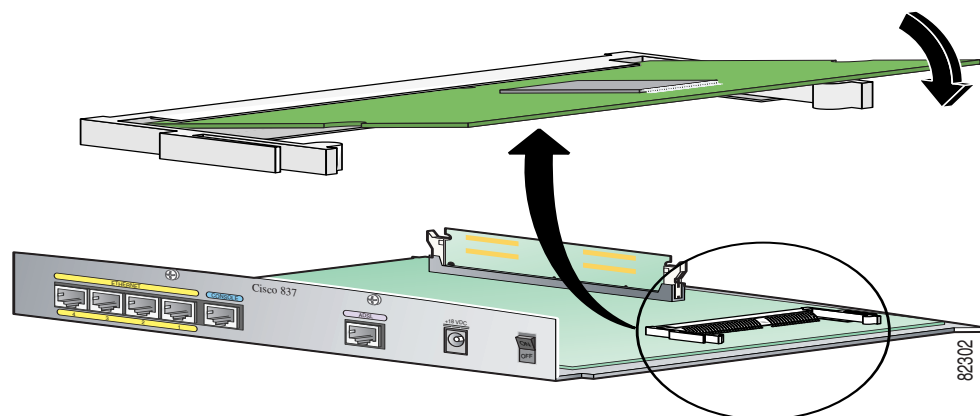

- Step 2** Firmly press down the unnotched edge of the module until you hear a click. The indents must be fully in the notches.

Removing a StrataFlash Memory Module

Follow these steps to remove a StrataFlash memory module:

- Step 1** Place your thumbs on the levers at the two sides of the slot, and push open, as shown in [Figure 9](#).

Figure 9 Removing a StrataFlash Memory Module

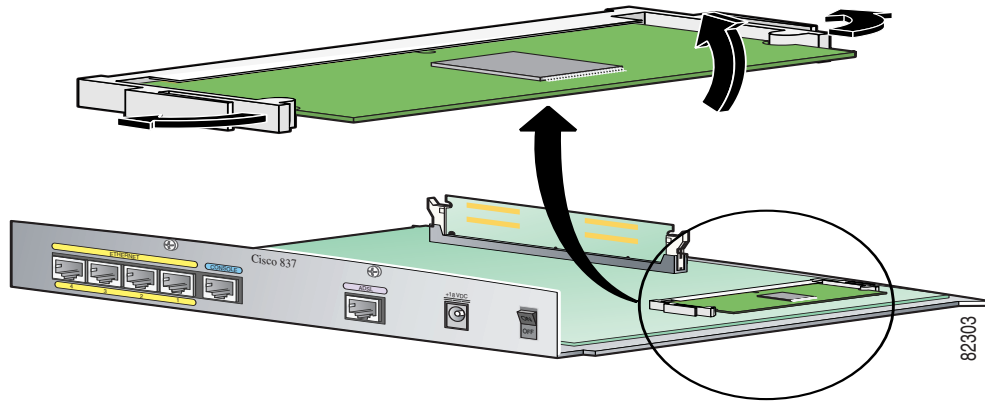

- Step 2** Firmly pull the release lever away from the module until the module pops up. You can then remove the module from the module slot.

Upgrading the DRAM

This section describes how to upgrade the DRAM in Cisco 800 series routers. Check the board to see whether it already has a DRAM module.



Note The Cisco SOHO series routers do not support DRAM upgrade.

[Table 5](#) shows the DRAM memory options for each model of the Cisco 800 series routers.

Table 5 DRAM Memory Options

Platform	DRAM Memory Card Options	Default DRAM Memory	Maximum DRAM Memory
Cisco 801–804 routers	4 MB or 8 MB	8 MB (4 MB of onboard DRAM and a 4-MB DRAM memory card)	12 MB
Cisco 805 routers	4 MB or 8 MB	8 MB (onboard DRAM only)	16 MB
Cisco 806 routers	4 MB, 8 MB, or 16 MB	32 MB (16 MB of onboard DRAM and a 16-MB DRAM memory card)	32 MB

Table 5 DRAM Memory Options (continued)

Platform	DRAM Memory Card Options	Default DRAM Memory	Maximum DRAM Memory
Cisco 811–813 routers	4 MB or 8 MB	8 MB (onboard DRAM only)	16 MB
Cisco 826, 827, and 827H routers	4 MB, 8 MB, or 16 MB	The default memory depends on the firmware: <ul style="list-style-type: none"> For Cisco IOS Base IP and IP firmware, 20 MB (16 MB of onboard DRAM and a 4-MB DRAM memory card) For Cisco IOS IP Plus and 3DES firmware, 24 MB (16 MB of onboard DRAM and an 8-MB DRAM memory card) 	32 MB
Cisco 827-4V routers	4 MB, 8 MB, 16 MB, or 32 MB	48 MB (16 MB onboard DRAM and 32-MB DRAM memory card)	48 MB
Cisco 828 Router	4 MB, 8 MB, or 16 MB	The default memory depends on the firmware: <ul style="list-style-type: none"> For Cisco IOS Base IP and IP firmware, 20 MB (16 MB of onboard DRAM and a 4-MB DRAM memory card) For Cisco IOS 3DES and IP Plus firmware, 24 MB (16 MB of onboard DRAM and an 8-MB DRAM memory card) 	32 MB
Cisco 831 ¹ , 836, and 837 routers	4 MB, 8 MB, or 16 MB	64 MB (onboard DRAM only)	80 MB
Cisco 851 and 857 routers	64 MB or 128 MB	64 MB (onboard DRAM only)	64 MB
Cisco 871, 876, 877, and 878 routers	64 MB or 128 MB	128 MB (onboard DRAM only)	256 MB

1. early 831 versions shipped with only 32MB onboard DRAM

Because of the height restriction of the actual DRAM component, you must order the additional DRAM from Cisco Systems.

You can order upgrade kits and have trained and qualified personnel add the memory.

Table 7 identifies the DRAM upgrade kits available for Cisco 801–806, 811–813, 826–828, 831, 836, and 837 routers.

Table 6 *Dynamic RAM Upgrade Kits for Cisco 801–806, 811–813, and 826–828, 831, 836, and 837 Routers*

Description	Cisco Part Number
4-MB DRAM module	MEM800-4D=
8-MB DRAM module	MEM800-8D=
16-MB DRAM module	MEM820-16D=

Table 7 identifies the DRAM upgrade kits available for Cisco 871, 876, 877, 878 routers.

Table 7 *Dynamic RAM Upgrade Kits for Cisco 871, 876, 877, 878 Routers*

Description	Cisco Part Number
64-MB DRAM module	MEM870-64D=
128-MB DRAM module	MEM870-128D=

Locating the DRAM Slot

Figure 10 shows where the DRAM module can be installed on the router motherboard. The DRAM socket location is similar on all Cisco 800 series routers.

Figure 10 *Location of DRAM*

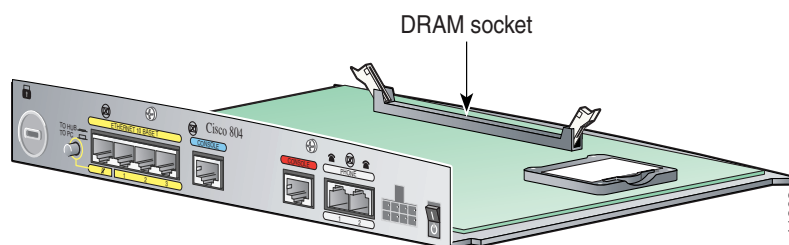

Installing the DRAM

To upgrade the DRAM, you must install the dual in-line memory module (DIMM) on the router motherboard.

Follow these steps to install a DIMM:

- Step 1** If a DIMM is already installed in the slot, firmly push the slot guides away from the DIMM and down toward the motherboard, as shown in Figure 11, until the DIMM pops out of the slot.

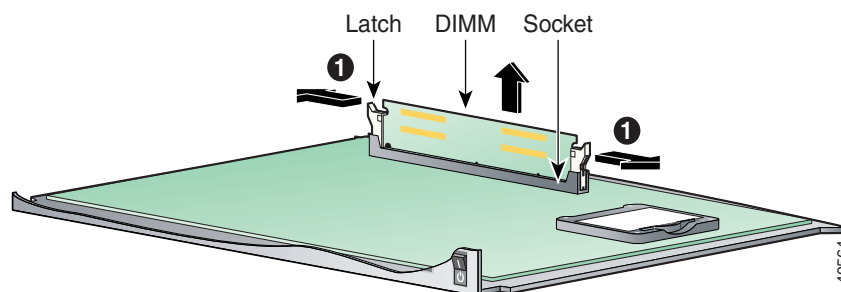
Figure 11 Removing a DIMM

- Step 2** Insert the new DIMM into the slot, making sure that the notches on the edge of the DIMM are inserted over the bars inside the slot, as shown in [Figure 12](#).

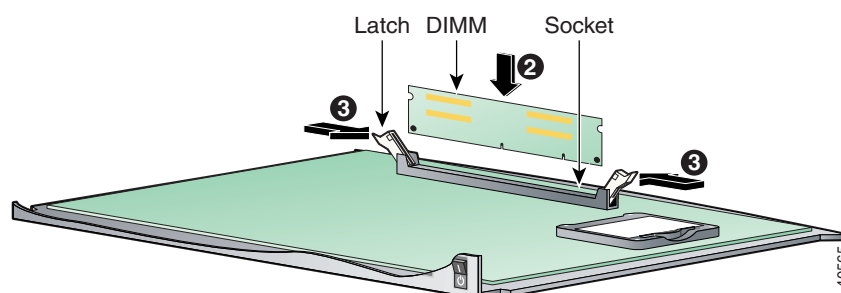

Note The DIMM orientation for the Cisco 801–804 and 805 routers is 180 degrees opposite the DIMM orientation for the Cisco 827 router.

Figure 12 Installing a DIMM

- Step 3** Firmly press the DIMM into the slot until the two slot guides on each side move up and over the DIMM edges, and you hear a click. If the guides do not move up and over the DIMM edges, move them with your hands.

Closing the Chassis

Follows these steps to close the chassis:

- Step 1** Place the router cover upside down, with the front of the cover facing you. Notice the two rectangular tabs near the bottom of the front cover.
- Step 2** Pick up the router bottom and turn it upside down, with the back panel facing away from you. Notice the two hooks along the router bottom.
- Step 3** Hold the front of the router bottom at an angle so that the hooks slip under the tabs on the front cover, as shown in [Figure 13](#).

Figure 13 Closing the Chassis

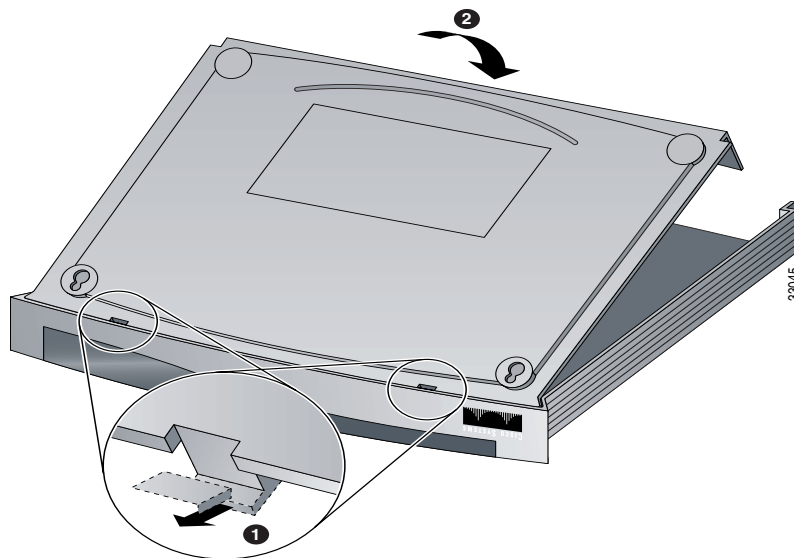

- Step 4** Lower the back of the router bottom.
The router bottom and the bottom of the front cover should be aligned.
- Step 5** Turn the router chassis over so that the back panel is facing you.
- Step 6** Replace the two screws that you removed when you opened the chassis. (See [Figure 1 on page 2.](#))

This document is to be used in conjunction with the other documents for the router you are upgrading.

CCDE, CCENT, Cisco Eos, Cisco Lumin, Cisco Nexus, Cisco StadiumVision, the Cisco logo, DCE, and Welcome to the Human Network are trademarks; Changing the Way We Work, Live, Play, and Learn is a service mark; and Access Registrar, Aironet, AsyncOS, Bringing the Meeting To You, Catalyst, CCDA, CCDP, CCIE, CCIP, CCNA, CCNP, CCSP, CCVP, Cisco, the Cisco Certified Internetwork Expert logo, Cisco IOS, Cisco Press, Cisco Systems, Cisco Systems Capital, the Cisco Systems logo, Cisco Unity, Collaboration Without Limitation, EtherFast, EtherSwitch, Event Center, Fast Step, Follow Me Browsing, FormShare, GigaDrive, HomeLink, Internet Quotient, IOS, iPhone, iQ Expertise, the iQ logo, iQ Net Readiness Scorecard, iQuick Study, IronPort, the IronPort logo, LightStream, Linksys, MediaTone, MeetingPlace, MGX, Networkers, Networking Academy, Network Registrar, PCNow, PIX, PowerPanels, ProConnect, ScriptShare, SenderBase, SMARTnet, Spectrum Expert, StackWise, The Fastest Way to Increase Your Internet Quotient, TransPath, WebEx, and the WebEx logo are registered trademarks of Cisco Systems, Inc. and/or its affiliates in the United States and certain other countries.

All other trademarks mentioned in this document or Website are the property of their respective owners. The use of the word partner does not imply a partnership relationship between Cisco and any other company. (0805R)

Upgrading Memory in Cisco 800 Series Routers
Copyright © 2005, Cisco Systems, Inc.
All rights reserved.