



MPLS Label Switching Router MIB

The MPLS Label Switching Router MIB (MPLS-LSR-MIB) allows you to use the Simple Network Management Protocol (SNMP) to remotely monitor a label switching router (LSR) that is using the Multiprotocol Label Switching (MPLS) technology. The MPLS-LSR-MIB mirrors a portion of the Cisco MPLS subsystem; specifically, it mirrors the MPLS Forwarding Infrastructure (MFI).

Feature History for MPLS Label Switching Router MIB

Release	Modification
12.0(14)ST	This feature was introduced on Cisco IOS Release 12.0(14)ST
12.2(2)T	This feature was integrated into Cisco IOS Release 12.2(2)T.
12.0(22)S	This feature was implemented on the Cisco 12000 series routers and integrated into Cisco IOS Release 12.0(22)S.
12.2(14)S	This feature was integrated into Cisco IOS Release 12.2(14)S and implemented on Cisco 7200 and Cisco 7500 series routers.
12.2(25)S	This feature was updated to work in the MPLS High Availability environment with the Cisco 7500 series routers.

Finding Support Information for Platforms and Cisco IOS Software Images

Use Cisco Feature Navigator to find information about platform support and Cisco IOS software image support. Access Cisco Feature Navigator at <http://www.cisco.com/go/fn>. You must have an account on Cisco.com. If you do not have an account or have forgotten your username or password, click **Cancel** at the login dialog box and follow the instructions that appear.



Corporate Headquarters:
Cisco Systems, Inc., 170 West Tasman Drive, San Jose, CA 95134-1706 USA

Copyright © 2004 Cisco Systems, Inc. All rights reserved.

Contents

This document includes the following major sections:

- [Information About MPLS Label Switching Router MIB, page 2](#)
- [How to Configure the MPLS LSR MIB, page 14](#)
- [Configuration Examples for the MPLS LSR MIB, page 16](#)
- [Additional References, page 16](#)
- [Command Reference, page 18](#)
- [Glossary, page 19](#)

Information About MPLS Label Switching Router MIB

The MPLS-LSR-MIB contains managed objects that support the retrieval of label switching information from a router. The MIB is based on Revision 05 of the IETF MPLS-LSR-MIB. This implementation enables a network administrator to get information on the status, character, and performance of the following:

- MPLS-capable interfaces on the LSR
- Incoming MPLS segments (labels) at an LSR and their associated parameters
- Outgoing segments (labels) at an LSR and their associated parameters

In addition, the network administrator can retrieve the status of cross-connect table entries that associate MPLS segments with each other.

Figure 1 shows the association of the cross-connect table with incoming and outgoing segments (labels).

Figure 1 Label Forwarding with the Cross-Connect Table

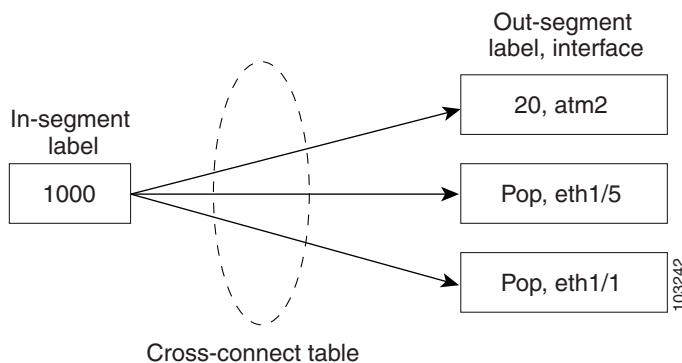

Note

The out-segment table does not display “no label” entries. Labels that are displayed as “POP” are the special MPLS label 3.

The notation used in the MPLS-LSR-MIB follows the conventions defined in Abstract System Notation One (ASN.1). ASN.1 defines an Open System Interconnection (OSI) language used to describe data types independently from particular computer structures and presentation techniques. Each object in the MIB incorporates a DESCRIPTION field that includes an explanation of the object’s meaning and usage,

which, together with the other characteristics of the object (SYNTAX, MAX-ACCESS, and INDEX) provides sufficient information for management application development, as well as for documentation and testing.

The MPLS-LSR-MIB represents an ASN.1 notation reflecting an idealized MPLS LSR.

A network administrator can access the entries (objects) in the MPLS-LSR-MIB by means of any SNMP-based network management system (NMS). The network administrator can retrieve information in the MPLS-LSR-MIB using standard SNMP **get** and **getnext** operations.

Typically, SNMP runs as a low-priority process. The response time for the MPLS-LSR-MIB is expected to be similar to that for other MIBs. The size and structure of the MIB and other MIBs in the system influence response time when you retrieve information from the management database. Traffic through the LSR also affects SNMP performance. The busier the switch is with forwarding activities, the greater the possibility of lower SNMP performance.

MPLS-LSR-MIB Elements

The top-level components of the MPLS-LSR-MIB consist of

- Tables and scalars (mplsLsrObjects)
- Traps (mplsLsrNotifications and mplsLsrNotifyPrefix)
- Conformance (mplsLsrConformance)

This Cisco implementation does not support the notifications defined in the MIB, nor does it support the labelStackTable or the trafficParamTable.

MPLS-LSR-MIB Tables

The Cisco implementation of the MPLS-LSR-MIB supports four main tables:

- Interface configuration
- In-segment
- Out-segment
- Cross-connect

The MIB contains three supplementary tables to supply performance information. This implementation does not support the label stack and traffic parameter tables.

The following sections list the MPLS-LSR-MIB tables (main and supplementary), their functions, table objects that are supported, and table objects that are *not* supported.

MPLS interface configuration table (mplsInterfaceConfTable)

Provides information for each MPLS-capable interface on an LSR.

Supports:

- A unique interface index or zero
- Minimum and maximum values for an MPLS label received on the interface
- Minimum and maximum values for an MPLS label sent from the interface
- A value for an MPLS label sent from the interface
- Per platform (0) or per interface (1) setting
- The storage type

Does not support:

- The total usable bandwidth on the interface
- The difference between the total usable bandwidth and the bandwidth in use

MPLS interface performance table (mplsInterfacePerfTable)

Augments the MPLS interface configuration table.

Supports:

- The number of labels in the incoming direction in use
- The number of top-most labels in outgoing label stacks in use

Does not support

- The number of top-most labels in outgoing label stacks in use
- The number of labeled packets discarded because no cross-connect entries exist
- The number of outgoing MPLS packets requiring fragmentation for transmission

MPLS in-segment table (mplsInSegmentTable)

Contains a description of incoming segments (labels) at an LSR and their associated parameters.

Administrative and operational status objects for this table control packet transmission. If administrative and operational status objects are down, the LSR does not forward packets. If these status objects are up, the LSR forwards packets.

Supports:

- A unique index identifier
- The incoming label
- The number of labels to pop from the incoming segment
- An address family number from the Internet Assigned Number Authority (IANA)
- A segment cross-connect entry association
- The segment owner
- The storage type
- The administrative status
- The operational status



Note

The administrative status and operational status are always up for inSegments in the Cisco implementation. Otherwise, these entries do not appear in the table.

Does not support:

- A pointer to a traffic parameter table entry (set to the default 0.0)

MPLS in-segment performance table (mplsInSegmentPerfTable)

Augments the MPLS in-segment table, providing performance information and counters for incoming segments on an LSR.

Supports:

- The number of 32-bit octets received
- The number of 64-bit octets received
- The time of the last system failure that corresponded to one or more incoming segment discontinuities

**Note**

The lastFailure parameter is set to zero because it has no meaning in the Cisco implementation.

Does not support:

- The total number of packets received
- The number of packets with errors
- The number of labeled packets discarded with no errors

MPLS out-segment table (mplsOutSegmentTable)

Contains a description of outgoing segments from an LSR and their associated parameters.

Administrative and operational status objects for this table control packet transmission. If administrative and operational status objects are down, the LSR does not forward packets. If these values are up, the LSR forwards packets.

Supports:

- A unique index identifier
- An interface index of the outgoing interface
- An indication of whether or not a top label is pushed onto the outgoing packet's label stack
- The label to push onto the outgoing packet's label stack (if the previous value is true)
- The next hop address type
- The IPv4 address of the next hop
- The segment cross-connect entry association
- The segment owner
- The storage type
- The administrative status
- The operational status

**Note**

The administrative and operational status entries are always up in the Cisco implementation. Otherwise, the administrative and operational status entries do not appear in the table.

Does not support:

- An IPv6 address of the next hop.
- A pointer to a traffic parameter table entry (set to the default 0.0).

MPLS out-segment performance table (mplsOutSegmentPerfTable)

Augments the MPLS out-segment table, providing performance information and counters for outgoing segments on an LSR.

Supports:

- The number of 32-bit octets sent
- The time of the last system failure that corresponded to one or more outgoing segment discontinuities

Does not support:

- The number of packets sent.
- The number of packets that could not be sent because of errors
- The number of packets discarded with no errors.
- The number of 64-bit octets sent

MPLS cross-connect table (mplsXCTable)

Associates inSegments (labels) to outSegments (labels) to show the manager how the LSR is currently swapping these labels.

A row in this table consists of one cross-connect entry that is indexed by the cross-connect index, the interface index of the incoming segment, the incoming label, and the out-segment index.

The administrative and operational objects for this table control packet forwarding to and from a cross-connect entry (XCEntry). The administrative status and operational status are always up in the Cisco implementation. Otherwise, the LSR would not forward packets.

Supports:

- A unique index identifier for a group of cross-connect segments
- A label switched path (LSP) to which the cross-connect entry belongs
- An index to the MPLS label stack table that identifies the stack of labels to be pushed under the top label
- An indication whether or not to restore the cross-connect entry after a failure (the default value is false)
- The cross-connect owner
- The storage type
- The administrative status (if up)
- Tunnel IDs (the tunnel instance for the MPLS TE tunnel entry)
- The operational status (if up)

**Note**

The administrative status and operational status are always up in the Cisco implementation. Otherwise, these status entries do not appear in the table.

Does not support:

NA

Information from Scalar Objects

The MPLS-LSR-MIB supports several scalar objects. In the Cisco implementation of the MIB, the following scalar objects are hard-coded to the value indicated and are read-only objects:

- `mplsOutSegmentIndexNext (0)`—The value for the out-segment index when an LSR creates a new entry in the MPLS out-segment table. The 0 indicates that this is not implemented because modifications to this table are not allowed.
- `mplsXCTIndexNext (0)`—The value for the cross-connect index when an LSR creates an entry in the MPLS cross-connect table. The 0 indicates that no unassigned values are available.
- `mplsMaxLabelDepth(2)`—The value for the maximum stack depth.
- `mplsLabelStackIndexNext (0)`—The value for the label stack index when an LSR creates entries in the MPLS label stack table. The 0 indicates that no unassigned values are available.
- `mplsTrafficParamIndexNext (0)`—The value for the traffic parameter index when an LSR creates entries in the MPLS traffic parameter table. The 0 indicates that no unassigned values are available.

The following scalar objects do not contain information for the MPLS-LSR-MIB and are coded as false:

- `mplsInSegmentTrapEnable (false)`—In-segment traps are not sent when this value is false.
- `mplsOutSegmentTrapEnable (false)`—Out-segment traps are not sent when this value is false.
- `mplsXCTrapEnable (false)`—Cross-connect traps are not sent when this value is false.

No trap information exists to support the MIB. Therefore, the following traps are not supported:

- `mplsInSegmentUp`
- `mplsInSegmentDown`
- `mplsOutSegmentUp`
- `mplsOutSegmentDown`
- `mplsXCUp`
- `mplsXCDown`

Linking Table Elements

In the cross-connect table, cross-connect entries associate incoming segments and interfaces with outgoing segments and interfaces. The following objects index the cross-connect entry:

- Cross-connect index—A unique identifier for a group of cross-connect entries in the cross-connect table. In the Cisco implementation, this value is always the same as that for the outSegmentIndex, unless there is no label or if the label has been popped.
- Interface index of the in-segment—A unique index for an entry in the in-segment table that represents an incoming MPLS interface. The value 0 means platform wide, for any entries that apply to all interfaces.
- Incoming label—An entry in the in-segment table that represents the label on the incoming packet.
- Out-segment index—A unique identifier for an entry in the out-segment table that contains a top label for the outgoing packet's label stack and an interface index of the outgoing interface.

Figure 2 shows the links between the in-segment and the out-segment in the cross-connect table.

Figure 2 Cross-Connect Table Links

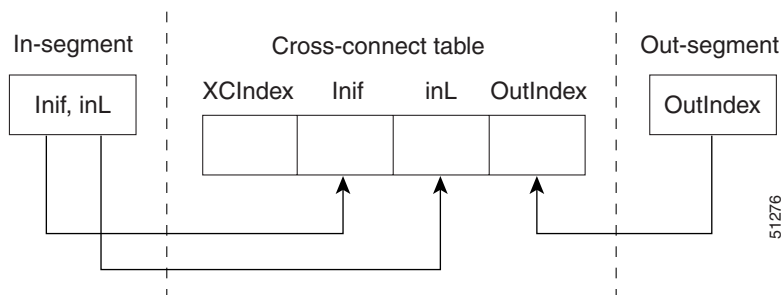

Table 1 shows the cross-connect table links you might see in the output from SNMP **get** operations on the MPLS-LSR-MIB objects that index a cross-connect entry. These objects include

- In-Segment Values—mplsInSegmentIfIndex and mplsInSegmentLabel
- Cross-Connect Entry—mplsXCIndex
- Out-Segment Values—mplsOutSegmentIndex

Table 1 MPLS LSR Output Showing Cross-Connect Table Links

In-Segment Values	Cross-Connect Entry	Out-Segment Values
0 ¹ , 1000	500 ² , 0, 1000, 0 ²	—
	501, 0, 1000, 501	501 = Pop (topLabel), Eth 1/5
	502, 0, 1000, 502	502 = Pop (topLabel), Eth, 1/1)

1. All MPLS-enabled interfaces can receive incoming labels.
2. For this implementation of the MPLS-LSR-MIB, the cross-connect index and the out-segment index are the same. If there is no outsegment, the value will be zero.



Note

The OutSegmentIndex object is not the label. The label can be retrieved from the mplsOutSegmentTopLabel object.

Interface Configuration Table and Interface MIB Links

The MPLS interface configuration table lists interfaces that support MPLS technology. An LSR creates an entry dynamically in this table for each MPLS-capable interface. An interface becomes MPLS-capable when MPLS is enabled on that interface. A non-zero index for an entry in this table points to the ifIndex for the corresponding interface entry in the ifTable of the Interfaces Group MIB.

The ifTable contains information on each interface in the network. Its definition of an interface includes any sublayers of the internetwork layer of the interface. MPLS interfaces fit into this definition of an interface. Therefore, each MPLS-enabled interface is represented by an entry in the ifTable.

The interrelation of entries in the ifTable is defined by the interfaces stack group of the Interfaces Group MIB. Figure 3 shows how the stack table might appear for MPLS interfaces. The underlying layer refers to any interface that is defined for MPLS internetworking, for example, ATM, Frame Relay, or Ethernet.

Figure 3 Interface Group MIB Stack Table for MPLS Interfaces

MPLS-interface ifType = mpls(166)
Underlying Layer . . .

51273



Note

Tunnel interfaces are included in the MPLS list for the current implementation.

The incoming and outgoing packets include a reference to the interface index for the ifTable of the Interfaces Group MIB. Figure 4 shows the links between MPLS-LSR-MIB objects and the Interfaces Group MIB.

Figure 4 MPLS-LSR-MIB and Interfaces Group MIB Links

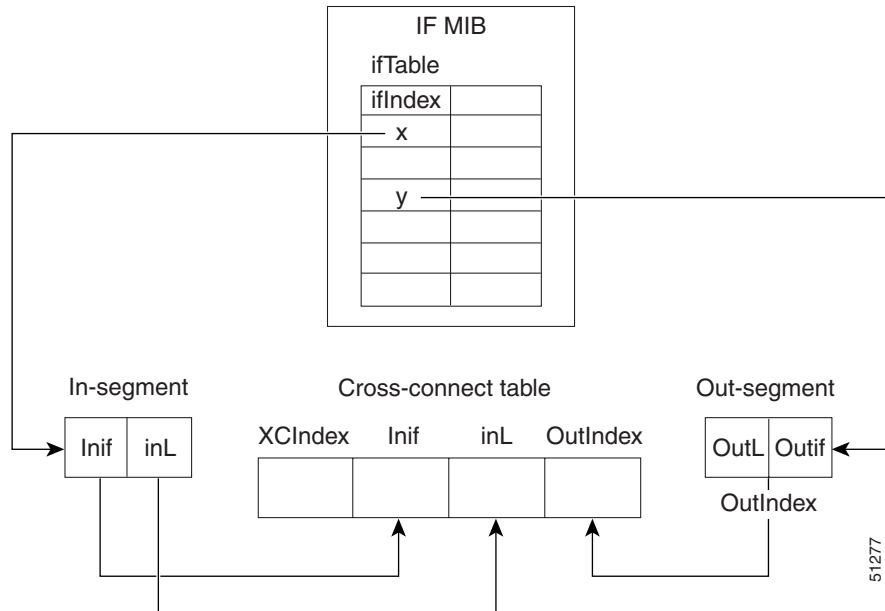

- For the Interfaces Group MIB (IF MIB):
 - ifTable represents the MPLS interface table.
 - ifIndex represents the index to an entry in the MPLS interface table.
- For the In-segment:
 - Inif represents the interface on the incoming segment (references an index entry in the ifTable).
 - inL represents the label on the incoming segment.
- For the Out-segment:
 - OutL represents the label on the outgoing segment.
 - Outif represents the interface on the outgoing segment (references an index entry in the ifTable).
- For the Cross-connect table:
 - XCIndex represents the index to an entry in the MPLS cross-connect table.
 - Inif represents the interface on the incoming segment.
 - inL represents the MPLS label on the incoming segment.
 - OutIndex represents an index to an entry in the MPLS out-segment table.

Using the MPLS-LSR-MIB

The MPLS-LSR-MIB enables you to display the contents of the MPLS Label Forwarding Information Base (LFIB). It gives you the same information that you can obtain using the CLI command **show mpls forwarding-table**.

However, the MPLS-LSR-MIB approach offers these advantages over the CLI command approach:

- A more efficient use of network bandwidth
- Greater interoperability among vendors
- Greater security (SNMP Version 3)

The following paragraphs describe the MPLS-LSR-MIB structure and show, through the use of an example, how the two approaches to the information display compare.

MPLS-LSR-MIB Structure

MIB structure is represented by a tree hierarchy. Branches along the tree have short text strings and integers to identify them. Text strings describe object names, and integers allow computer software to encode compact representations of the names.

The MPLS-LSR-MIB falls on the experimental branch of the Internet MIB hierarchy. The experimental branch of the Internet MIB hierarchy is represented by the object identifier 1.3.6.1.3. This branch can also be represented by its object name *iso.org.dod.internet.experimental*. The MPLS-LSR-MIB is identified by the object name *mplsLsrMIB*, which is denoted by the number 96. Therefore, objects in the MPLS-LSR-MIB can be identified in either of the following ways:

- The object identifier—1.3.6.1.3.96.[MIB-variable]
- The object name—*iso.org.dod.internet.experimental.mplsLsrMIB.[MIB-variable]*

To display a *MIB-variable*, you enter an SNMP **get** command with an object identifier. Object identifiers are defined by the MPLS-LSR-MIB.

[Figure 5](#) shows the position of the MPLS-LSR-MIB in the Internet MIB hierarchy.

Figure 5 *MPLS-LSR-MIB in the Internet MIB Hierarchy*

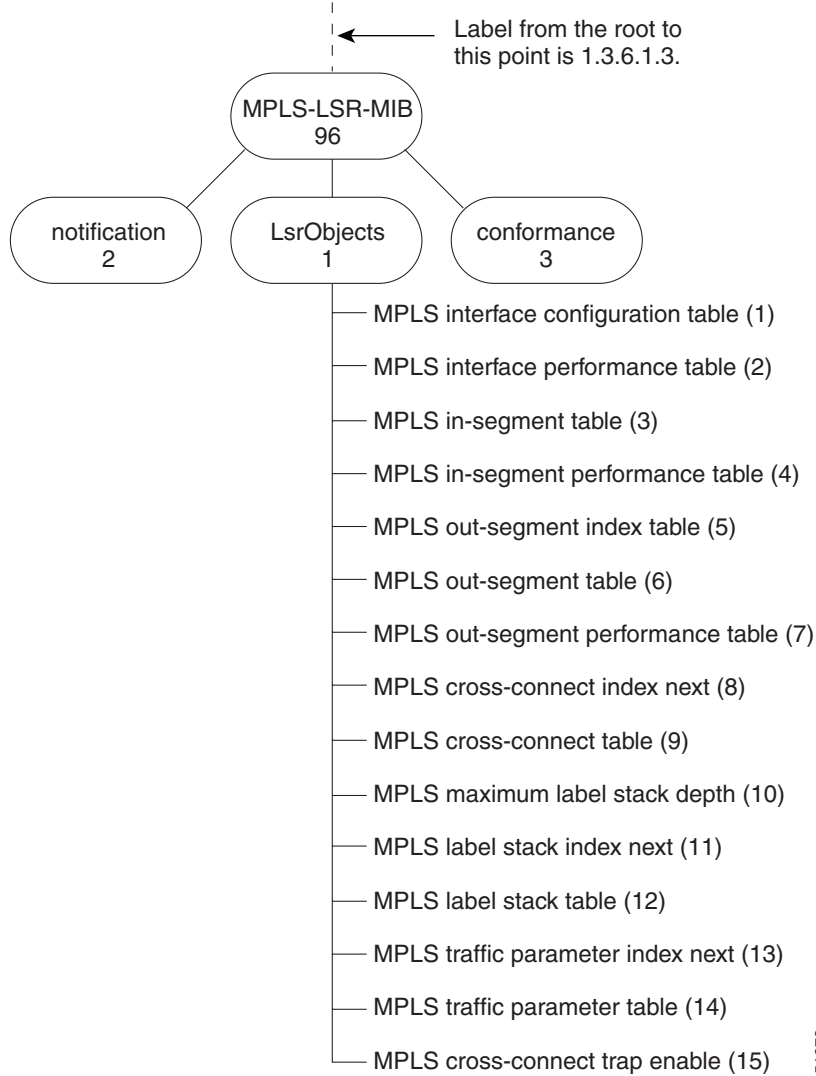

51272

CLI Commands and the MPLS-LSR-MIB

The MPLS LFIB is the component of the Cisco MPLS subsystem that contains management information for LSRs. You can access this management information by means of either of the following:

- Using the **show mpls forwarding-table** CLI command
- Entering SNMP **get** commands on a network manager

The following examples show how you can gather LSR management information using both methods.

CLI Command Output

A **show mpls forwarding-table** CLI command allows you to look at label forwarding information for a packet on a specific MPLS LSR.

```
Router# show mpls forwarding-table
Local  Outgoing      Prefix          Bytes Label  Outgoing  Next Hop
Label  Label or VC   or Tunnel Id    Switched     interface
19     Pop Label     10.3.4.0/24     0            Et1/4     10.22.23.23
22     23           172.16.14.14/32 0            AT2/0.1   point2point
       1/36        192.168.14.14/32 0            AT2/0.2   point2point
```

MPLS-LSR-MIB Output

SNMP commands on MIB objects also allow you to look at the label forwarding information for a specific MPLS LSR.

You can do a walk-through of the MIB by running a command such as **getmany -v2c public mplsLsrMIB** on a network manager where **getmany** does repeated SNMP **getnext** operations to retrieve the contents of the MPLS-LSR-MIB.

```
mplsXCOperStatus.9729.0.19.9729 = up(1)
mplsXCOperStatus.11265.0.22.11265 = up(1)
mplsXCOperStatus.11266.0.22.11266 = up(1)
```

You can continue to scan the output of the **getmany** command for the following (from the MPLS out-segment table):

- Out-segment's top label objects (mplsOutSegmentTopLabel)

```
mplsOutSegmentTopLabel.9729 = 3
mplsOutSegmentTopLabel.11265 = 23
mplsOutSegmentTopLabel.11266 = 65572
```



Note

65572 is 1/36 in label form (1 is the high-order 16 bits. 36 is the low-order 16 bits.)

- Out-segment's interface index (mplsOutSegmentIfIndex)

```
mplsOutSegmentIfIndex.9729 = 7
mplsOutSegmentIfIndex.11265 = 28
mplsOutSegmentIfIndex.11266 = 31
```

Benefits

The benefits described in the following paragraphs are available to you with the MPLS-LSR-MIB.

Troubleshooting LSR Problems

By monitoring the cross-connect entries and the associated incoming and outgoing segments, you can see which labels are installed and how they are being swapped. Use the MPLS-LSR-MIB in place of the **show mpls forwarding** CLI command.

Monitoring of LSR Traffic Loads

By monitoring interface and packet operations on an MPLS LSR, you can identify high- and low-traffic patterns, as well as traffic distributions.

Improvement of Network Performance

By identifying potentially high-traffic areas, you can set up load sharing to improve network performance.

Verification of LSR Configuration

By comparing results from SNMP **get** commands and the **show mpls forwarding** CLI command, you can verify your LSR configuration.

Displaying of Active Label Switched Paths

By monitoring the cross-connect entries and the associated incoming segments and outgoing segments, you can determine the active LSPs.

How to Configure the MPLS LSR MIB

See the following sections for configuration tasks for the MPLS-LSR-MIB feature. Each task in the list is identified as either optional or required.

- [Enabling the SNMP Agent](#) (required)
- [Verifying That the SNMP Agent Has Been Enabled](#) (optional)

Prerequisites

The MPLS-LSR-MIB requires the following:

- SNMP installed and enabled on the LSR
- MPLS enabled on the LSR
- 60K of memory



Note Additional capacity is not required for runtime dynamic random-access memory (DRAM).

Enabling the SNMP Agent

The SNMP agent for the MPLS-LSR-MIB is disabled by default. To enable the SNMP agent, perform the following steps:

SUMMARY STEPS

1. **enable**
2. **show running-config**
3. **configure terminal**
4. **snmp-server community** *string* [**view** *view-name*] [**ro**] [*number*]
5. **end**
6. **write memory**

DETAILED STEPS

	Command or Action	Purpose
Step 1	enable Example: Router> enable	Enables privileged EXEC mode. <ul style="list-style-type: none">• Enter your password if prompted.
Step 2	show running-config Example: Router# show running-config	Displays the running configuration of the router to determine if an SNMP agent is already running on the device. If no SNMP information is displayed, continue with the next step. If any SNMP information is displayed, you can modify the information or change it as desired.
Step 3	configure terminal Example: Router# configure terminal	Enters global configuration mode.
Step 4	snmp-server community <i>string</i> [view <i>view-name</i>] [ro] [<i>number</i>] Example: Router(config)# snmp-server community public ro	Configures read-only (ro) SNMP community strings.
Step 5	end Example: Router(config)# end	Exits to privileged EXEC mode.
Step 6	write memory Example: Router# write memory	Writes the modified SNMP configuration into NVRAM of the router, permanently saving the SNMP settings.

Verifying That the SNMP Agent Has Been Enabled

To verify that the SNMP agent has been enabled, perform the following steps:

Step 1 Access the router through a Telnet session:

```
Prompt# telnet xxx.xxx.xxx.xxx
```

where *xxx.xxx.xxx.xxx* represents the IP address of the target device.

Step 2 Enter privileged mode:

```
Router# enable
```

Step 3 Display the running configuration and look for SNMP information:

```
Router# show running-configuration
...
...
snmp-server community public RO
```

If you see any “snmp-server” statements, SNMP has been enabled on the router.

Configuration Examples for the MPLS LSR MIB

The following example shows how to enable an SNMP agent.

```
Router# configure terminal
Router(config)# snmp-server community
```

In the following example, SNMPv1 and SNMPv2C are enabled. The configuration permits any SNMP manager to access all objects with read-only permissions using the community string *public*.

```
Router(config)# snmp-server community public
```

In the following example, read-only access is allowed for all objects to members of access list 4 that specify the *comaccess* community string. No other SNMP managers have access to any objects.

```
Router(config)# snmp-server community comaccess ro 4
```

Additional References

The following sections provide references related to the MPLS LSR MIB:

- [Related Documents, page 17](#)
- [Standards, page 17](#)
- [MIBs, page 17](#)
- [RFCs, page 17](#)
- [Technical Assistance, page 17](#)

Related Documents

Related Topic	Document Title
Configuring SNMP using Cisco IOS software	<ul style="list-style-type: none"> • <i>Cisco IOS Configuration Fundamentals Configuration Guide, Release 12.2</i>, Configuring SNMP Support • <i>Cisco IOS Configuration Fundamentals Command Reference, Release 12.2</i>, SNMP Commands

Standards

Standards	Title
draft-ietf-mpls-lsr-mib-05.txt	<i>MPLS Label Switch Router Management Information Base Using SMIv2</i>
draft-ietf-mpls-arch-07.txt	<i>Multiprocol Label Switching Architecture</i>

MIBs

MIBs	MIBs Link
<ul style="list-style-type: none"> • MPLS Label Switching Router MIB (MPLS-LSR-MIB) 	<p>To locate and download MIBs for selected platforms, Cisco IOS releases, and feature sets, use Cisco MIB Locator found at the following URL:</p> <p>http://www.cisco.com/go/mibs</p>

RFCs

RFCs	Title
The LSR implementation supporting the MPLS-LSR-MIB is in full compliance with all provisions of Section 10 of RFC 2026.	<i>The Internet Standards Process</i>

Technical Assistance

Description	Link
Technical Assistance Center (TAC) home page, containing 30,000 pages of searchable technical content, including links to products, technologies, solutions, technical tips, and tools. Registered Cisco.com users can log in from this page to access even more content.	http://www.cisco.com/public/support/tac/home.shtml

Command Reference

None

Glossary

cross-connect (XC)—An association of insegments and incoming MPLS interfaces to outsegments and outgoing MPLS interfaces.

IETF—Internet Engineering Task Force. A task force (consisting of more than 80 working groups) that is developing standards for the Internet and the IP suite of protocols.

inSegment—A label on an incoming packet that is used to determine the forwarding of the packet.

Internet Engineering Task Force—See IETF.

label—A short, fixed length identifier that is used to determine the forwarding of a packet.

Label Distribution Protocol—See LDP.

label switched path—See LSP.

label switching—A term used to describe the forwarding of IP (or other network layer) packets using a label swapping algorithm based on network layer routing algorithms. The forwarding of these packets uses the exact match algorithm and rewrites the label.

label switching router—See LSR.

LDP—Label Distribution Protocol. A standard protocol between MPLS-enabled routers that is used for the negotiation of the labels (addresses) used to forward packets.

LSP—label switched path. A sequence of hops in which a packet travels from one router to another router by means of label switching mechanisms. A label-switched path can be established dynamically, based on normal routing mechanisms, or through configuration.

LSR—label switching router. A device that forwards MPLS packets based on the value of a fixed-length label encapsulated in each packet.

MFI—MPLS Forwarding Infrastructure. In the Cisco MPLS subsystem, the data structure for storing information about incoming and outgoing labels and associated equivalent packets suitable for labeling.

Management Information Base—See MIB.

MIB—Management Information Base. Database of network management information that is used and maintained by a network management protocol such as SNMP. The value of a MIB object can be changed or retrieved by means of SNMP commands, usually through a network management system. MIB objects are organized in a tree structure that includes public (standard) and private (proprietary) branches.

MPLS—Multiprotocol Label Switching. MPLS is a method for forwarding packets (frames) through a network. It enables routers at the edge of a network to apply labels to packets (frames). ATM switches or existing routers in the network core can switch packets according to the labels with minimal lookup overhead.

MPLS interface—An interface on which MPLS traffic is enabled.

Multiprotocol Label Switching—See MPLS.

notification request—Message sent by an SNMP agent to a network management station, console, or terminal, indicating that a significant event occurred. SNMP notification requests are more reliable than traps, because a notification request from an SNMP agent requires that the SNMP manager acknowledge receipt of the notification request. The manager replies with an SNMP response protocol data unit (PDU). If the manager does not receive a notification message from an SNMP agent, it does not send a response. If the sender (SNMP agent) never receives a response, the notification request can be sent again. Thus, a notification request is more likely than a trap to reach its intended destination.

outSegment—A label on an outgoing packet.

Simple Network Management Protocol—See SNMP.

SNMP—Simple Network Management Protocol. Management protocol used almost exclusively in TCP/IP networks. SNMP provides a means for monitoring and controlling network devices, and for managing configurations, statistics collection, performance, and security.

trap—Message sent by an SNMP agent to a network management station, console, or terminal, indicating that a significant event occurred. Traps are less reliable than notification requests, because the receiver does not send an acknowledgment when it receives a trap. The sender cannot determine if the trap was received.

CCVP, the Cisco logo, and Welcome to the Human Network are trademarks of Cisco Systems, Inc.; Changing the Way We Work, Live, Play, and Learn is a service mark of Cisco Systems, Inc.; and Access Registrar, Aironet, Catalyst, CCDA, CCDP, CCIE, CCIP, CCNA, CCNP, CCSP, Cisco, the Cisco Certified Internetwork Expert logo, Cisco IOS, Cisco Press, Cisco Systems, Cisco Systems Capital, the Cisco Systems logo, Cisco Unity, Enterprise/Solver, EtherChannel, EtherFast, EtherSwitch, Fast Step, Follow Me Browsing, FormShare, GigaDrive, HomeLink, Internet Quotient, IOS, iPhone, IP/TV, iQ Expertise, the iQ logo, iQ Net Readiness Scorecard, iQuick Study, LightStream, Linksys, MeetingPlace, MGX, Networkers, Networking Academy, Network Registrar, PLX, ProConnect, ScriptShare, SMARTnet, StackWise, The Fastest Way to Increase Your Internet Quotient, and TransPath are registered trademarks of Cisco Systems, Inc. and/or its affiliates in the United States and certain other countries.

All other trademarks mentioned in this document or Website are the property of their respective owners. The use of the word partner does not imply a partnership relationship between Cisco and any other company. (0711R)

Copyright © 2004 Cisco Systems, Inc. All rights reserved.