



NetFlow on Logical Interfaces: Frame Relay, Asynchronous Transfer Mode, Inter-Switch Link, 802.1q, Multilink Point to Point Protocol, General Routing Encapsulation, Layer 2 Tunneling Protocol, Multiprotocol Label Switching VPNs, and Tunnel

Last Updated: March 2006

INTRODUCTION

NetFlow is a Cisco IOS® Software feature, designed to track, document and—optionally—accelerate the flow of IP packets as they traverse a network. NetFlow services are available on Cisco IOS Software-based routers, as well as the Cisco Catalyst® 5000 and 6000 series switches.

NetFlow provides two key benefits to the end user. First, by tracking IP flows, NetFlow produces a detailed record of traffic flows on a network. This record can be used for a variety of purposes, including accounting, billing, network planning, traffic engineering, and user/application monitoring.

Second, because NetFlow keeps a cache of active IP flows, it can be used in conjunction with Cisco Express Forwarding as a highly optimized routing cache, accelerating the flow of data as it passes from interface to interface. In addition, because the first packet of an IP flow is evaluated against any existing access control lists (ACLs), all subsequent packets belonging to the same flow are processed as “preauthenticated.” This further speeds packet processing, without any loss in security.

NetFlow data records can be exported to an external UNIX workstation running the Cisco NetFlow FlowCollector application. These exported records can be analyzed by the Cisco Network Data Analyzer program or by a variety of third-party applications.

OBJECTIVES

This paper examines how NetFlow is implemented on logical interfaces. Logical interfaces can be divided into two groups:

- Subinterfaces, such as those encountered on Frame Relay or ATM
- Virtual interfaces, found in technologies like L2TP, GRE tunnels, or MPLS-VPN

While the implementation of NetFlow on physical interfaces is straightforward, deploying NetFlow on logical interfaces often raises numerous questions.

- How is NetFlow configured on a logical interface?
- What does the output look like?
- Are there any anomalies in this type of implementation?

METHODOLOGY

Cisco has tested nine different scenarios:

- Frame Relay subinterfaces
- ATM subinterfaces
- Inter-Switch Link (ISL) subinterfaces
- 802.1q subinterfaces

- Multilink PPP interfaces
- Generic Routing Encapsulation (GRE) tunnel interfaces
- Layer 2 Tunneling Protocol (L2TP) VPDN-group interfaces
- MPLS-VPN interfaces
- Tunnel Hopping (packet arrived on one tunnel interface of a router, and was routed to a different tunnel interface on the same router)

All tests were conducted using Cisco IOS Software Release 12.1(5)T.

The testbeds were kept as simple as possible, as were the router configurations and the number of flows traversing the devices within the testbed. This was intentional. The simplicity of the configurations should enhance the clarity of the results.

As an example, in almost all real-world deployments, a GRE tunnel will be secured with some encryption scheme. However, since encryption would not have changed the output data of NetFlow, encryption was not implemented on the GRE tunnels in the testbed.

TEST RESULTS

Overview

Testing yielded very few surprises. Results were consistent with the intuitive expectations of how NetFlow should work on logical interfaces.

Before proceeding to the individual test results, here is a discussion of the NetFlow output produced by the command `sh ip cache flow`:

Figure 1. Sample NetFlow Output

Line	7200-netflow#sh ip cache flow															
1	IP packet size distribution (1693 total packets):															
2	1-32	64	96	128	160	192	224	256	288	320	352	384	416	448	480	
3	.000	.190	.190	.615	.000	.000	.000	.000	.000	.000	.000	.000	.000	.000	.000	
4	512	544	576	1024	1536	2048	2560	3072	3584	4096	4608					
5	.000	.000	.003	.000	.000	.000	.000	.000	.000	.000	.000					
6	IP Flow Switching Cache, 4456704 bytes															
7	2 active, 65534 inactive, 7 added															
8	120 ager polls, 0 flow alloc failures															
9	Active flows timeout in 30 minutes															
10	Inactive flows timeout in 15 seconds															
11	last clearing of statistics 00:03:18															
12	Protocol	Total	Flows	Packets	Bytes	Packets	Active (Sec)	Idle (Sec)								
13	-----	Flows	/Sec	/Flow	/Pkt	/Sec	/Flow	/Flow								
14	TCP-Telnet	3	0.0	12	106	0.1	4.2	15.8								
15	ICMP	2	0.0	500	100	5.2	2.6	15.4								
16	Total:	5	0.0	207	100	5.4	3.6	15.6								
17	SrcIfl	SrcIPaddress	DstIfl	DstIPaddress	Pr	SrcP	DstP	Pkts								
18	Se3/0.16	10.1.10.1	Fa4/0	192.168.10.1	01	0000	0800	650								
19	Se3/0.16	10.1.10.1	Fa4/0	192.168.10.1	06	0017	2AFF	6								

The first portion of the output—Lines 1-5—is the packet size distribution. What percentage of packets of each size has passed through this router? This information can be very useful for network troubleshooting, traffic engineering, and capacity planning.

Lines 6-8 describe the parameters assigned to NetFlow itself. The default number of flows that NetFlow can cache is 65536. In this case, two of these cache entries were in use, and 65534 were available for new flows. The size of the NetFlow cache can be modified with the command `ip flow-cache entries <number>`, where <number> is a value between 1024 and 524288.

Lines 9-11 show how long a particular flow will stay in the cache. In this example, if there had been no activity on the flow for 15 seconds, the entry would have been purged from the cache. If an entry has been in the cache for 30 minutes, it is purged—even if there is still traffic for it. A new cache entry is built upon the receipt of the next packet for that particular flow. Connection-oriented entries, such as telnet or FTP, are purged as soon as the session is closed.

Lines 12-16 provide a breakdown of flows by protocol. Again, this is an ideal tool for the network administrator, because it provides traffic distribution by type. This information can be used very effectively in application monitoring.

Lines 17-19 show the actual NetFlow cache entries. This portion of the NetFlow output will be the focus of the subsequent sections of this paper.

For purposes of clarity and brevity only selected portions of router configurations and router console output will be displayed in the remainder of this paper. For complete configurations and console output please refer to the appendices.

Frame Relay

Figure 2 shows a simplified diagram of the Frame Relay testbed.

Figure 2. Frame Relay Testbed

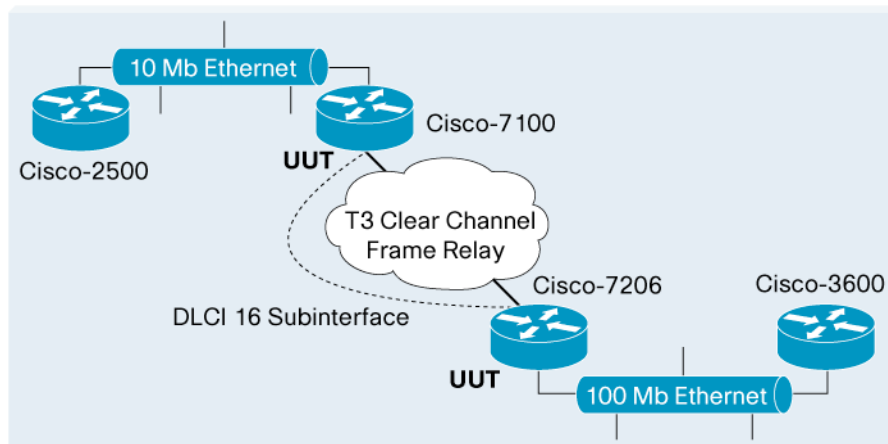

As seen in Figure 2, there were two different units under test (UUTs): the 7206 and the 7140. These are the relevant portions of the configuration for both units.

Figure 3. 7206 Frame Relay Configuration

```
7206
!  
ip cef  
!
```

```

interface Serial3/0
 ip address 172.16.10.2 255.255.255.0
 encapsulation frame-relay
 ip route-cache flow
 no keepalive
 framing c-bit
 cablelength 10
 dsu bandwidth 44210
 frame-relay map ip 172.16.10.1 17 broadcast
!
interface Serial3/0.16 point-to-point
 ip address 172.16.11.2 255.255.255.0
 frame-relay interface-dlci 16
!

```

Figure 4. 7140 Frame Relay Configuration

```

7140
!
ip cef
!
interface Serial1/1
 ip address 172.16.10.1 255.255.255.0
 encapsulation frame-relay
 ip route-cache flow
 no keepalive
 framing c-bit
 dsu bandwidth 44210
 cablelength 10
 frame-relay map ip 172.16.10.2 17 broadcast
!
interface Serial1/1.16 point-to-point
 ip address 172.16.11.1 255.255.255.0
 frame-relay interface-dlci 16
!

```

Both UUTs had a physical serial port using Frame Relay encapsulation. They also had a subinterface defined between them using interface-dlci 16.

In most tests, to keep the results simple and informative, the number of flows traversing the two routers was limited to:

- A series of pings from the 2500 to the 3640
- A telnet session from the 3640 to the 2500

The NetFlow cache on a router can be displayed with the command `sh ip cache flow`. This was the output from both routers:

Figure 5. 7140 Frame Relay NetFlow Output

```
7100-NetFlow#sh ip cache flow
SrcIf          SrcIPAddress  DstIf          DstIPAddress  Pr SrcP DstP  Pkts
Se1/1.16      192.168.10.1 Fa0/0          10.1.10.1     01 0000 0000    5
Se1/1.16      192.168.10.1 Fa0/0          10.1.10.1     06 2AFF 0017    4
```

Figure 6. 7206 Frame Relay NetFlow Output

```
7200-netflow#sh ip cache flow
SrcIf          SrcIPAddress  DstIf          DstIPAddress  Pr SrcP DstP  Pkts
Se3/0.16      10.1.10.1    Fa4/0          192.168.10.1  01 0000 0800  650
Se3/0.16      10.1.10.1    Fa4/0          192.168.10.1  06 0017 2AFF    6
```

A closer look at the flow table for the 7206 router (Figure 6) provides the following information:

- A packet had arrived on interface Se3/0.16, which is the Frame Relay subinterface
- The packet was sourced from IP address 10.1.10.1, and was sent out on interface Fa4/0 to IP address 192.168.10.1
- The Protocol type was 01, which is ICMP
- Although ICMP doesn't normally use port numbers, the ICMP packet type (0800) was parsed as the destination port. This was an ICMP PING echo request packet
- Finally, there was a packet count of 650 packets having traversed this flow

Similarly, examining the second line:

- A packet was received on Frame Relay subinterface Se3/0.16
- As before, the packet was sourced from IP address 10.1.10.1, and was sent out on interface Fa4/0 to IP address 192.168.10.1
- The Protocol type was 06, which is TCP
- The source and destination TCP port numbers were 0017 and 2AFF hex, respectively. Port 0017 is a reserved TCP port. Therefore, 192.168.10.1 had an open telnet session to 10.1.10.1
- Only six packets had used this flow thus far

Although the goal was to track flows on the subinterfaces, the command `ip route-cache flow` was issued on the physical serial port Se3/0. At present, using NetFlow on a per-subinterface basis is not supported. When enabling NetFlow on the physical port, NetFlow records for all subinterfaces associated with that port are received. This is not necessarily a problem. In most situations where NetFlow is used (traffic engineering, billing, etc.), that level of granular detail is needed.

Since both the ping and the Telnet session were part of a two-way flow of traffic, we might expect four NetFlow records, rather than two. For each traffic type, one flow represents traffic on the way out; another flow represents traffic on the way back. However, with one exception to be discussed later, NetFlow only track flows on the physical ingress port, not the egress port. In this example, NetFlow had been disabled intentionally on interface Fa4/0, so that this issue could be illustrated. In order to track the two-way nature of IP traffic flows, it is necessary to enable NetFlow on all interfaces of a router.

This is why there were two UUTs in this particular testbed. Without enabling NetFlow on all interfaces, only half of the story was obtained. The output line from the 7140 represents the "echo reply" to the "echo request" seen on the 7206:

Figure 7. Corresponding Flow from 7140 Router

SrcIf	SrcIPaddress	DstIf	DstIPaddress	Pr	SrcP	DstP	Pkts
Se1/1.16	192.168.10.1	Fa0/0	10.1.10.1	01	0000	0000	5

In the configuration of both the 7206 and the 7140, ip cef was globally enabled. This was a very important step, since NetFlow works hand-in-hand with CEF (Cisco Express Forwarding) switching to provide flow acceleration. If global CEF is not enabled before creating subinterfaces, Cisco IOS Software will frequently append the command no ip route-cache cef to the subinterface description when is created. This behavior can interfere with proper NetFlow flow acceleration.

Equally important is what was **not** seen in the NetFlow output. Although NetFlow was enabled on the Se3/0 interface and the packet (physically) arrived on this interface, nevertheless no NetFlow record existed citing Se3/0 as the source interface. NetFlow correctly understood that the packet “belonged” to the subinterface. This is only mentioned since, later in this paper, there will be situations where the same traffic appears on both the physical interface and the logical one. Thus, there is a danger of counting the same traffic twice. However, in this example, there was no danger of double counting.

ATM

The ATM test case was remarkably similar to the Frame Relay one. However, in this example, NetFlow was enabled on the Ethernet interfaces as well as the ATM interfaces. As mentioned in the last section, this should give a more complete picture of traffic flow. Thus, in this configuration, only one UUT was needed to get a complete picture of the traffic traversing the router.

Figure 8. ATM Testbed

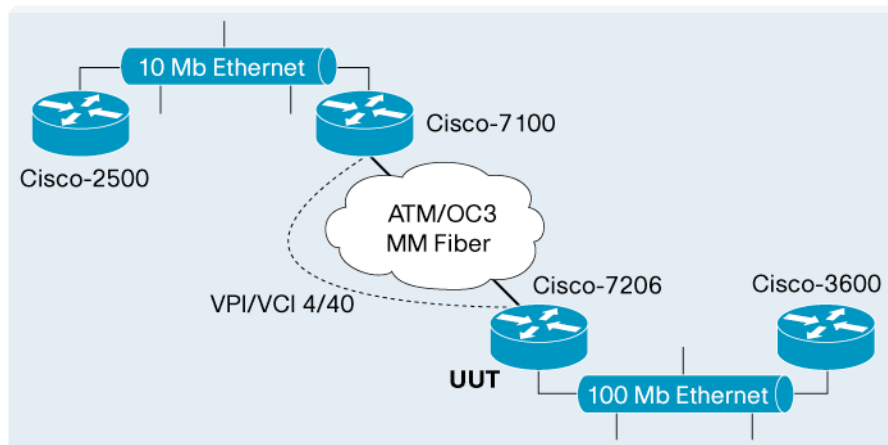

Relevant portions of the ATM configuration are reproduced here:

Figure 9. 7206 ATM Configuration

```
7206
!
interface ATM1/0
 no ip address
 ip route-cache flow
 no atm ilmi-keepalive
!
```

```

interface ATM1/0.1 point-to-point
 ip address 172.16.11.2 255.255.255.0
 pvc 4/40
  encapsulation aal5snap
!
!
interface FastEthernet4/0
 ip address 192.168.10.2 255.255.255.0
 ip route-cache flow
 half-duplex
!

```

This was the output from the ATM unit under test:

Figure 10. 7206 ATM NetFlow Output

```

7200-netflow#sh ip cache flow

```

SrcIf	SrcIPAddress	DstIf	DstIPAddress	Pr	SrcP	DstP	Pkts
AT1/0.1	10.1.10.1	Fa4/0	192.168.10.1	01	0000	0800	1131
Fa4/0	192.168.10.1	AT1/0.1	10.1.10.1	01	0000	0000	1131
Fa4/0	192.168.10.1	AT1/0.1	10.1.10.1	06	2AF8	0017	3
AT1/0.1	10.1.10.1	Fa4/0	192.168.10.1	06	0017	2AF8	3

In this configuration, ip route-cache flow was enabled on the physical interface to gain information about IP flows on the subinterfaces. Even though the ATM parent interface did not have an IP address assigned, it was still the correct place to enable ip route-cache flow.

Having enabled NetFlow on both the ATM and Ethernet interfaces, a more complete picture of the traffic flows through this router was obtained. For example, in the route cache, an ICMP flow (ping echo request) arrived on interface ATM1/0.1 from IP address 10.1.10.1 destined for IP address 192.168.10.1 on interface Fa4/0. Because there was some visibility of flows on the Ethernet port, the ICMP echo reply, which arrived on interface Fa4/0 destined for interface AT1/0.1, could be seen.

With NetFlow enabled on all applicable interfaces, there was no need for the output of both routers (as in the Frame Relay example) to track the flow of IP packets.

INTER-SWITCH LINK (ISL)

ISL is a Cisco proprietary protocol that appends tags to individual frames so that multiple virtual LANs (VLANs) can coexist on the same physical media.

In order to test ISL, the layout of the testbed was altered slightly. Figure 11 shows a revised diagram of the ISL test.

Figure 11. ISL Testbed

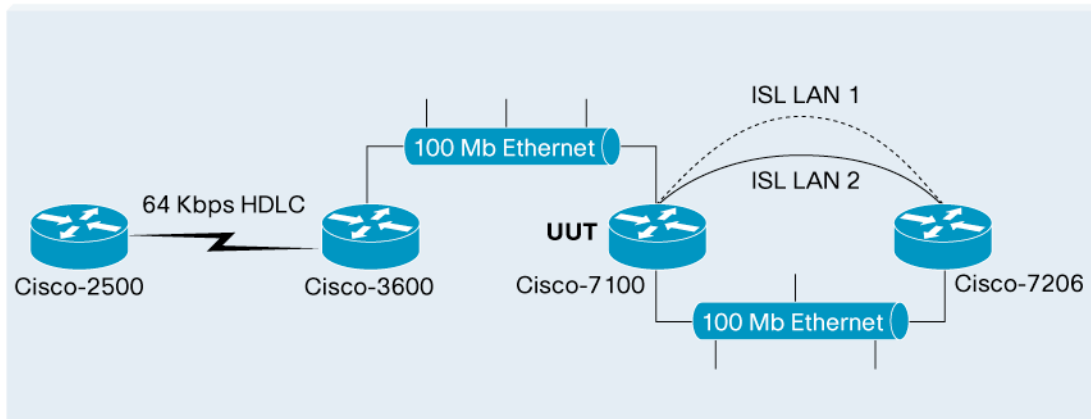

Figure 12 shows the relevant portion of the 7140 configuration. Note once again that NetFlow was enabled on the parent Ethernet interface, not on the subinterfaces.

Figure 12. 7140 ISL Configuration

```
!  
interface FastEthernet0/1  
no ip address  
ip route-cache flow  
duplex auto  
speed auto  
!  
interface FastEthernet0/1.1  
encapsulation isl 1  
ip address 192.168.10.1 255.255.255.0  
no ip redirects  
!  
interface FastEthernet0/1.2  
encapsulation isl 2  
ip address 192.168.11.1 255.255.255.0  
no ip redirects  
!
```

The output of the 7140 provided another interesting point about how NetFlow services act on virtual interfaces.

Figure 13. 7140 ISL NetFlow Output

SrcIf	SrcIPAddress	DstIf	DstIPAddress	Pr	SrcP	DstP	Pkts
Fa0/0	172.16.10.1	Fa0/1.1	192.168.10.2	06	2AF8	0017	2
Fa0/1.2	192.168.10.2	Fa0/0	172.16.10.1	06	0017	2AF8	1
Fa0/0	10.1.10.1	Fa0/1.2	192.168.11.2	01	0000	0800	6459
Fa0/1.2	192.168.11.2	Fa0/0	10.1.10.1	01	0000	0000	3230
Fa0/1.1	192.168.11.2	Fa0/0	10.1.10.1	01	0000	0000	5000

With two different IP flows having traversed this router, we could have expected to see four NetFlow cache records. However, we could clearly see five different records. What caused this?

On the echo reply ping packets, the 7206 router—which was the destination of the ping (192.168.11.2)—had two equal cost paths back to the source (10.1.10.1). Because the 7206 was the destination of the ping, the ping packets were process-switched, rather than fast-switched. As a result, the 7206 decided to load-share the responses across these paths. Thus, some of the responses were received on Fa0/1.1 and other responses on Fa0/1.2. (The numbers of echo requests versus echo replies didn't match exactly, since this was a snapshot of the NetFlow cache during ongoing testing.) Indeed, if there had been a little more traffic on the concurrent telnet session, we may have seen six different flows crossing this router.

From a NetFlow point of view, a flow is a unique combination of the source and destination IP addresses, source and destination TCP/UDP port numbers, IP protocol type, IP Type of Service, and input interface. Even though all the other fields match, because the input interfaces differed, NetFlow treated the echo responses as two separate flows.

This is not necessarily a problem, and it can be quite useful in some cases. For example, a network administrator can use this kind of detail to analyze the effectiveness of load-sharing performance.

802.1Q

The 802.1q test case was a small variation of the ISL case, since both ISL and 802.1q have a similar purpose: to isolate traffic that shares the same physical media using tags.

Figure 14. 802.1q Testbed

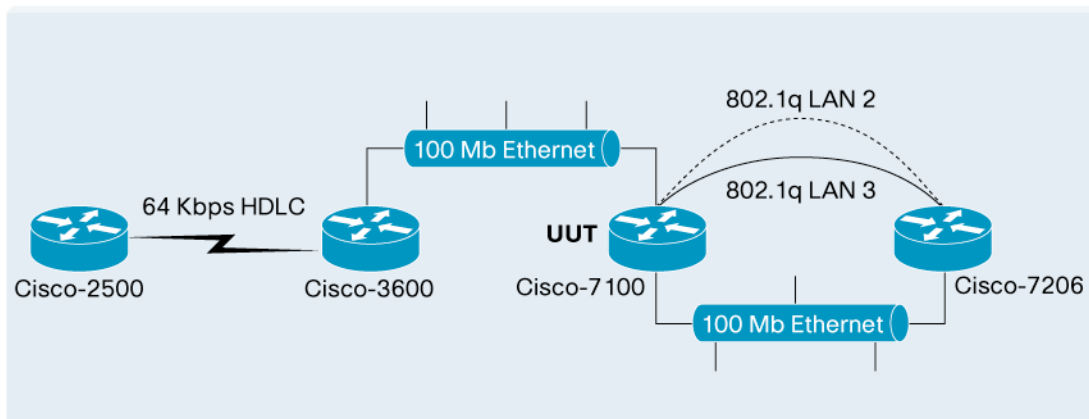

The testbed was almost identical to the previous ISL testbed:

The configuration was also very similar.

Figure 15. 7140 802.1q Configuration

```
!  
interface FastEthernet0/0  
 ip address 172.16.10.2 255.255.255.0  
 ip route-cache flow  
 duplex auto  
 speed auto  
!  
interface FastEthernet0/1  
 no ip address  
 ip route-cache flow  
 duplex auto  
 speed auto  
!  
interface FastEthernet0/1.1  
 encapsulation dot1Q 3  
 ip address 192.168.10.1 255.255.255.0  
 no ip redirects  
!  
interface FastEthernet0/1.2  
 encapsulation dot1Q 2  
 ip address 192.168.11.1 255.255.255.0  
 no ip redirects  
!
```

As expected from the discussion of load sharing in the previous section, six different NetFlow cache entries were seen.

Figure 16. 7140 802.1q NetFlow Output

SrcIf	SrcIPAddress	DstIf	DstIPAddress	Pr	SrcP	DstP	Pkts
Fa0/0	10.1.10.1	Fa0/1.1	192.168.10.2	01	0000	0800	3629
Fa0/1.2	192.168.10.2	Fa0/0	10.1.10.1	01	0000	0000	1908
Fa0/1.1	192.168.10.2	Fa0/0	10.1.10.1	01	0000	0000	1916
Fa0/0	10.1.10.1	Fa0/1.1	192.168.10.2	06	0017	2AF8	30
Fa0/1.1	192.168.10.2	Fa0/0	10.1.10.1	06	2AF8	0017	21
Fa0/1.2	192.168.10.2	Fa0/0	10.1.10.1	06	2AF8	0017	29

In this particular case, there was enough Telnet traffic for the 7206 to have load-shared its responses. Thus, six different IP flows were observed.

MULTILINK PPP

A multilink interface allows several serial lines to be bound together into a logical interface called a multilink-group. PPP traffic is distributed across interfaces within the group—either by fragmentation or load sharing. This allows for greater aggregate bandwidth than any of the individual links could provide. It also has the added benefit of reducing the number of interfaces which need to be managed on a router.

This discussion of multilink interfaces moves away from the concept of subinterfaces (which are tied to a physical “parent” port) and towards more “purely logical” type interfaces. With this conceptual change also come some changes in the manner in which NetFlow services are configured.

This is a diagram of the testbed:

Figure 17. Multilink PPP Testbed

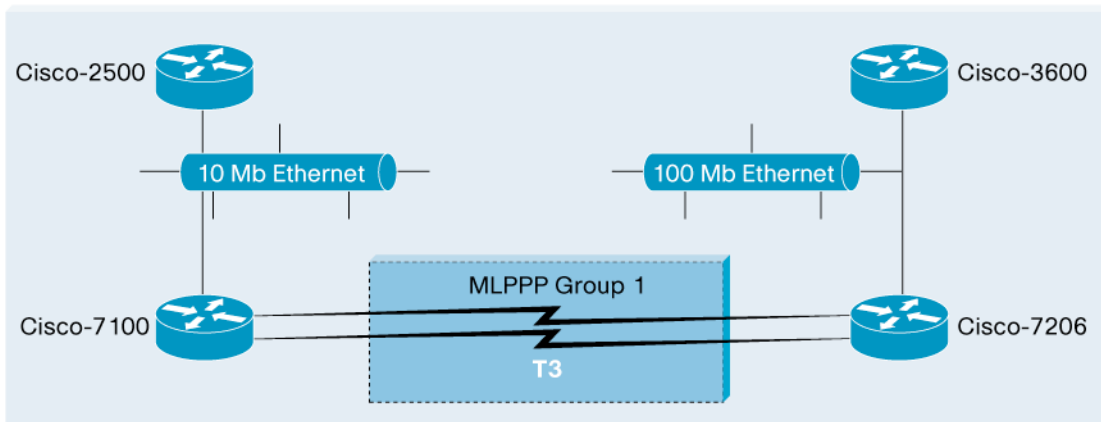

This is the relevant portion of the 7206 configuration.

Figure 18. 7206 Multilink PPP Configuration

```
interface Multilink1
 ip address 172.16.11.2 255.255.255.0
 ip route-cache flow
 ppp chap hostname 7206
 ppp multilink
 multilink-group 1
!
interface Serial2/0
 no ip address
 encapsulation ppp
 ip route-cache flow
 framing c-bit
 cablelength 10
 dsu bandwidth 44210
 ppp chap hostname 7206
 ppp multilink
 multilink-group 1
!
interface Serial3/0
 no ip address
 encapsulation ppp
```

```

ip route-cache flow
no keepalive
framing c-bit
cablelength 10
dsu bandwidth 44210
ppp chap hostname 7206
ppp multilink
multilink-group 1
!

```

Note that although ip route-cache flow was enabled on the serial interfaces, these interfaces did not show up in the NetFlow cache. In this configuration, it was not necessary to enable NetFlow on the serial interfaces. NetFlow was enabled on these interfaces solely to illustrate this point.

In the case of Multilink, the relevant configuration was the enabling of NetFlow on the Multilink interface itself. This contrasts with previous cases, where NetFlow was configured on the physical port to enable the caching on the logical interfaces. In this case, NetFlow was enabled directly on the logical multilink interface.

As seen in the results, the multilink interface MU1 was also logged as the source or destination of the IP flows:

Figure 19. 7206 Multilink PPP NetFlow Output

SrcIf	SrcIPAddress	DstIf	DstIPAddress	Pr	SrcP	DstP	Pkts
Mu1	10.1.10.1	Fa4/0	192.168.10.1	01	0000	0800	1971
Fa4/0	192.168.10.1	Mu1	10.1.10.1	01	0000	0000	2152
Mu1	10.1.10.1	Fa4/0	192.168.10.1	06	0017	2B05	8
Fa4/0	192.168.10.1	Mu1	10.1.10.1	06	2B05	0017	10

GENERIC ROUTING ENCAPSULATION (GRE)

In the past, it has been very difficult to route private enterprise traffic across the public service provider Internet. This is because many enterprise sites use the private address space defined in RFC 1918. These private addresses are not allowed to traverse the public Internet. GRE is one of several possible solutions to this problem.

GRE is a method of encapsulating protocol packets within IP. It is most frequently used for Virtual Private Networking (VPN), because it allows private enterprise traffic to be tunneled across the public Internet. Private traffic is directed across the tunnel interface by the routing table. In this test case, static routes direct the traffic across the tunnel.

As mentioned previously, the GRE tunnel in this testbed was not encrypted. Encryption would have added a few flows at the beginning of the connection setup (as the peer routers exchanged encryption keys), but would not have significantly changed the output.

Conceptually, the testbed looked like this:

Figure 20. GRE Testbed

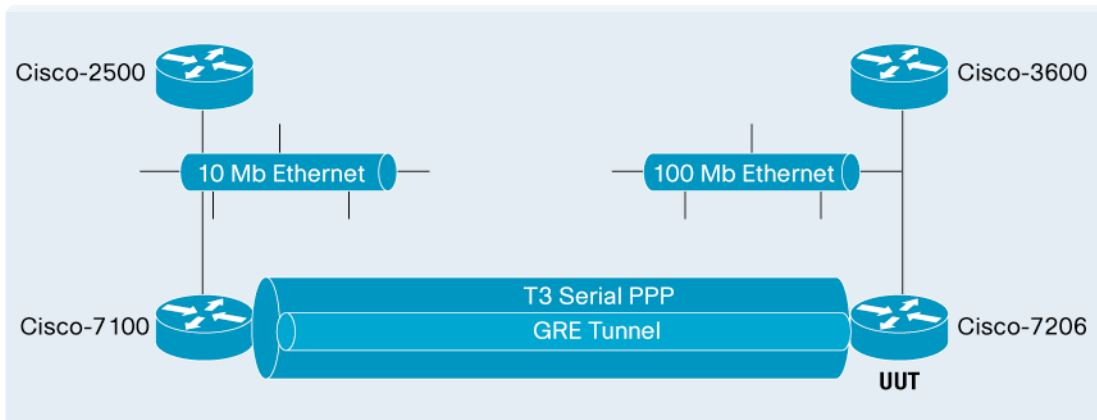

This is the relevant setup on the UUT, the 7206 router:

Figure 21. 7206 GRE Configuration

```
!
interface Tunnel0
 ip address 172.16.12.2 255.255.255.0
 ip route-cache flow
 tunnel source 172.16.11.2
 tunnel destination 172.16.11.1
!
ip route 10.1.10.0 255.255.255.0 Tunnel0
```

In this instance, NetFlow was enabled on the logical tunnel interface. This was similar to the configuration of multilink, and in contrast to ATM, ISL, and other subinterfaces.

The GRE tunnel added some new flows to the output:

Figure 22. 7206 GRE NetFlow Output

SrcIf	SrcIPAddress	DstIf	DstIPAddress	Pr	SrcP	DstP	Pkts
Se2/0	172.16.11.1	Local	172.16.11.2	2F	0000	0000	6300
Se2/0	172.16.11.1	Local	172.16.11.2	2F	0000	0000	29
Tu0	10.1.10.1	Fa4/0	192.168.10.1	01	0000	0800	6305
Fa4/0	192.168.10.1	Tu0	10.1.10.1	01	0000	0000	6305
Fa4/0	192.168.10.1	Tu0	10.1.10.1	06	2AF8	0017	34
Tu0	10.1.10.1	Fa4/0	192.168.10.1	06	0017	2AF8	29

The flows with protocol type 2F were the GRE tunnel flows themselves.

This particular testbed introduced a few anomalies that must be examined.

First, 6300 packets were received from IP address 172.16.11.1 on interface Se2/0. This was the other endpoint of the tunnel (on the 7140 router). Also, 6305 packets were received on Tu0 (the tunnel interface). It is vital to understand that the 6300 packets seen on interface Se2/0 were actually the same IP packets seen in the tunnel, just encapsulated in GRE.

Second, the first two lines of the output were identical (except for packet count):

Figure 23. NetFlow GRE Tunnel Flow Records

SrcIf	SrcIPAddress	DstIf	DstIPAddress	Pr	SrcP	DstP	Pkts
Se2/0	172.16.11.1	Local	172.16.11.2	2F	0000	0000	6300
Se2/0	172.16.11.1	Local	172.16.11.2	2F	0000	0000	29

Why, then, were they counted as different IP flows?

Remember the definition of a NetFlow IP flow: a unique combination of the source and destination IP addresses, source and destination TCP/UDP port numbers, IP protocol type, IP Type of Service, and the input interface.

In order to understand this cache entry, more information was needed. This was obtained with the command `sh ip cache verbose flow`. Here was the output of this command (edited for readability):

Figure 24. NetFlow Verbose Output

SrcIf	SrcIPAddress	DstIf	DstIPAddress	Pr	TOS	Flgs	Pkts
Se2/0	172.16.11.1	Local	172.16.11.2	2F	00	10	1098
Se2/0	172.16.11.1	Local	172.16.11.2	2F	C0	10	7

Port	Msk	AS	Port	Msk	AS	NextHop	B/Pk	Active
0000	/0	0	0000	/0	0	0.0.0.0	0	6.6
0000	/0	0	0000	/0	0	0.0.0.0	0	0.6

Note that the two flows had different Types of Service (ToS), which made them unique from a NetFlow point of view.

Finally, although there were complete records of the ping and Telnet sessions within the output, only one side of the GRE tunnel conversation itself was seen. This was a result of two factors.

- In most cases, NetFlow only tracks ingress traffic
- The 7206 router itself was the end-point of the tunnel

In order to view the NetFlow records for both sides of the tunnel connection, it was necessary to view the NetFlow cache on the 7140 router as well. There should have been two corresponding GRE records in that cache.

Figure 25. Corresponding 7140 GRE Flow Records

SrcIf	SrcIPAddress	DstIf	DstIPAddress	Pr	SrcP	DstP	Pkts
Se1/0	172.16.11.2	Local	172.16.11.1	2F	0000	0000	4707
Se1/0	172.16.11.2	Local	172.16.11.1	2F	0000	0000	26

LAYER 2 TUNNELING PROTOCOL

Layer 2 Tunneling Protocol (L2TP) is conceptually similar to GRE. As with GRE, L2TP can be used to tunnel private enterprise traffic across the public Internet. However, since L2TP tunnels PPP frames, it can benefit from the services that PPP provides, including multiprotocol encapsulation and negotiation, authentication, authorization, and accounting (AAA).

In a typical L2TP environment, a user dials into a special device known as an L2TP Access Concentrator (LAC) and is tunneled via the LAC to an L2TP Network Server (LNS), which acts as the endpoint for the user's PPP session.

L2TP provides a particularly interesting case, because the L2TP interfaces—where NetFlow caching would be enabled—are not preconfigured, but created dynamically from a virtual-template.

The lab setup had to be changed significantly to simulate this environment. A Cisco 7507 was added as the UUT. Also, the 7200 acting as the LAC was loaded with a special version of code that allowed it to spoof the behavior of a user dialing into a LAC server. So, while this was an emulated environment, the traffic received at the LNS was identical to what it would see in the real world.

Figure 26. L2TP Testbed

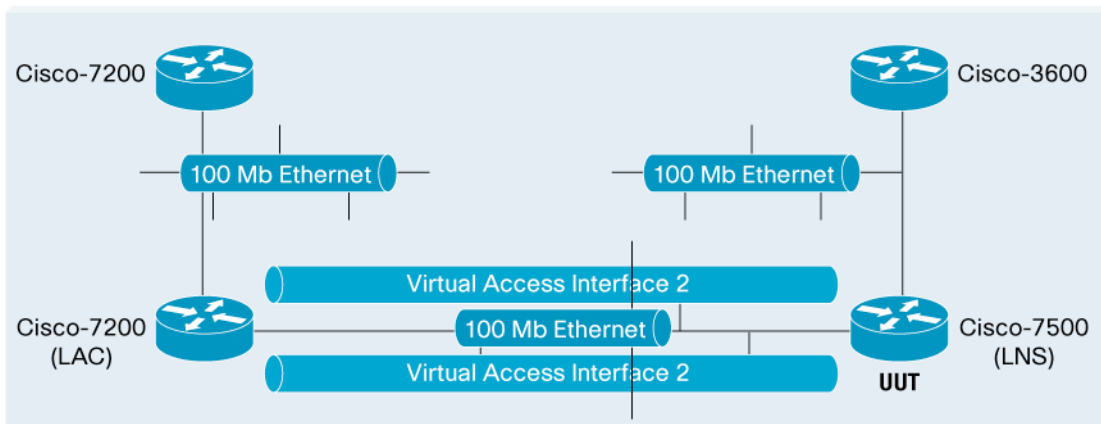

The configuration of the 7500 is detailed below. In this case, ip route cache flow was enabled on the Virtual-Template1 interface. As each call came in from the LAC, a Virtual-Access interface was created, based upon the contents of the Virtual-Template. Because of this dependency, each new Virtual-Access interface would automatically have NetFlow enabled.

Figure 27. 7500 LNS L2TP Configuration

```
ip cef
vpdn enable
no vpdn logging
!
vpdn-group 1
! Default L2TP VPDN group
accept-dialin
protocol l2tp
virtual-template 1
local name lns1
lcp renegotiation always
!
!
interface Virtual-Template1
ip unnumbered Loopback0
```

ip route-cache flow

```
load-interval 30
no keepalive
peer default ip address pool vpdn
ppp authentication chap
!
```

As is illustrated in the output below, NetFlow had no problem tracking the flows on the Virtual-Access interfaces, correctly identifying them as either the source or destination of IP traffic.

Figure 28. 7500 L2TP NetFlow Output

SrcIf	SrcIPAddress	DstIf	DstIPAddress	Pr	SrcP	DstP	Pkts
Fa0/1/0	10.3.1.1	Local	10.3.1.2	11	06A5	06A5	1010
Vi2	10.8.1.1	Fa4/1/0	15.2.254.254	06	0017	2AFB	520
Fa4/1/0	15.2.254.254	Vi2	10.8.1.1	06	2AFB	0017	144
Vi1	10.2.1.2	Fa4/1/0	15.1.254.254	01	0000	0800	504
Fa4/1/0	15.1.254.254	Vi1	10.2.1.2	01	0000	0000	504

As was the case with the GRE tunnel, a single entry represented the L2TP tunnel traffic itself. (Protocol 0x11 hex or 17 decimal which is UDP; port 0x06A5 hex or 1701 decimal, which is L2TP). Although there were two tunnels in the testbed, they were represented by a single flow in the output. The tunnel and session IDs that distinguish the individual tunnels were much further down in the payload of the UDP packet.

MULTIPROTOCOL LABEL SWITCHING-VIRTUAL PRIVATE NETWORK (MPLS-VPN)

Multiprotocol Label Switching is a standards-based extension of the Cisco IOS Software concept of tag-switching. In a typical implementation, IP traffic, as it is sent into a service provider's network, passes through a special router, known as a provider's edge (PE) router. This router assigns a special tag to the packet, which determines its next-hop destination. Because the routers within the service provider's core network are no longer routing this packet based on IP address, but on the information in the tag, this allows the service provider to offer a variety of value added services based on the tag. Quality of service (QoS) is one such service; a Virtual Private Network (VPN) is another.

MPLS provides a low-overhead alternative to the tunneling of private enterprise traffic across the public Internet. Because MPLS routers route based on tags rather than IP addresses, the private address scheme of the enterprise is hidden from the routers. Thus, a service provider can carry this private enterprise traffic across its public Internet core.

From a NetFlow point of view, the problem with MPLS is that it appends labels to the IP packets, so NetFlow can't easily read them and determine if they are part of an existing flow.

The solution to this problem was introduced in Cisco IOS Software Release 12.1(5)T with the new command `mpls netflow egress`. When using this command, NetFlow looks at MPLS packets on the egress port (after the label has been stripped), rather than the ingress port. This is currently the only instance in which NetFlow tracks egress traffic.

To simulate this behavior, Cisco constructed the following testbed.

Figure 29. MPLS-VPN Testbed

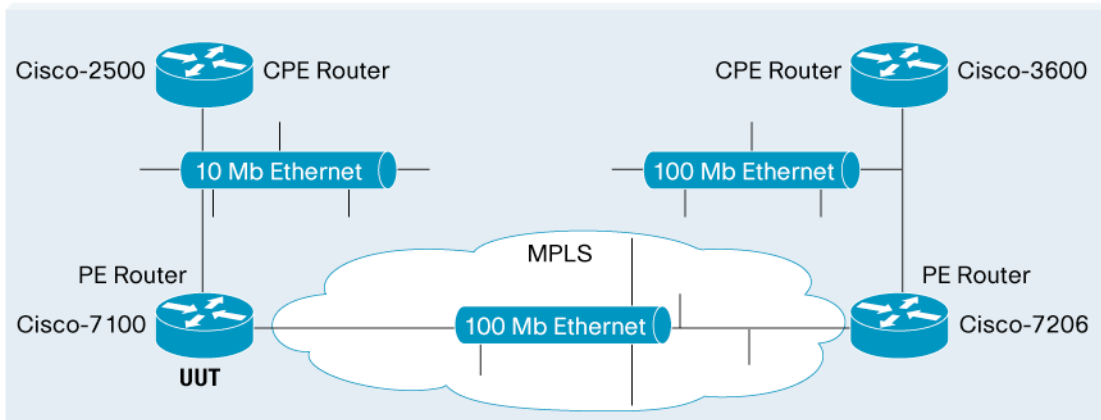

Granted, there was not much value in applying MPLS labels in this simple setup. However, the setup was sufficient for illustrating how mpls netflow egress works.

In this testbed, the 7140 played the role of the PE router. The relevant portions of the configuration are:

Figure 30. 7140 MPLS-VPN Configuration

```
ip vrf green
 rd 300:1
 route-target export 300:1
 route-target import 300:1
ip cef
!
interface FastEthernet0/0
 ip vrf forwarding green
 ip address 10.1.10.2 255.255.255.0
 ip route-cache flow
 duplex auto
 speed 10
 mpls netflow egress
!
interface FastEthernet0/1
 ip address 172.16.10.1 255.255.255.0
 duplex auto
 speed auto
 tag-switching ip
!
```

A VPN routing/forwarding (VRF) interface called “green” was created and associated with Fa0/0. On Fa0/0, which went to the customer premises equipment (CPE) 2500 router, both ip route-cache flow and mpls netflow egress were enabled. This provided visibility into both IP flows coming from the customer premises, as well as MPLS-VPN IP flows destined towards the customer premises.

Figure 31. 7140 MPLS-VPN NetFlow Output

SrcIf	SrcIPAddress	DstIf	DstIPAddress	Pr	SrcP	DstP	Pkts
Fa0/0	10.1.10.1	Fa0/1	192.168.10.1	01	0000	0800	2681
Fa0/1	192.168.10.1	Fa0/0	10.1.10.1	01	0000	0000	2786
Fa0/0	10.1.10.1	Fa0/1	192.168.10.1	06	0017	2AFA	8
Fa0/1	192.168.10.1	Fa0/0	10.1.10.1	06	2AFA	0017	10

Note: An MPLS VRF, itself, is not an interface. Thus, “vrf green” was not reported as a source interface for the NetFlow IP flows. Rather, the interface with which the VRF was associated was displayed.

It was anticipated that flows originating on Fa0/0 would have been seen, since ip route-cache flow was enabled on the Fa0/0 interface. Nevertheless, the ability to see the flows originating from Fa0/1 destined towards Fa0/0 was new behavior, based upon the implementation of mpls netflow egress. Both ingress and egress traffic can be tracked by configuration on a single interface. Indeed, examining Fa0/1—the MPLS ingress interface—it can be seen that it did not mention NetFlow at all.

TUNNEL HOPPING

This unusual case was added to the testbed in order to see whether NetFlow behavior changes when both the ingress and the egress ports were non-physical. In all other test cases, the IP flows were between a logical interface and a physical interface. In this instance, IP traffic was flowing from one logical interface to a different logical interface.

This is a conceptual diagram of the setup:

Figure 32. Tunnel Hopping Testbed

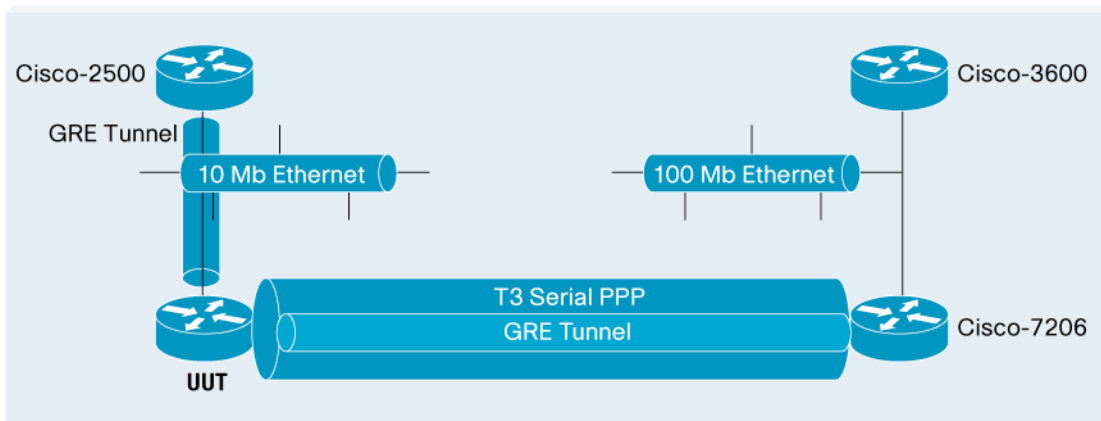

This time, the 7140 was configured with two different tunnels, to the 7206 and the 2500, respectively:

Figure 33. 7140 Tunnel Hopping Configuration

```
!  
interface Tunnel0  
ip address 172.16.12.1 255.255.255.0  
ip route-cache flow  
tunnel source 172.16.11.1  
tunnel destination 172.16.11.2
```

```

!
interface Tunnell
 ip address 10.1.20.2 255.255.255.0
 ip route-cache flow
 tunnel source 10.1.10.2
 tunnel destination 10.1.10.1
!

```

After generating some traffic which should have crossed the two tunnel interfaces, the following output was captured:

Figure 34. 7140 Tunnel Hopping NetFlow Output

```
7100-NetFlow#sh ip cache verbose flow
```

SrcIf	SrcIPAddress	DstIf	DstIPAddress	Pr	TOS	Flgs	Pkts
Fa0/0	10.1.10.1	Local	10.1.10.2	2F	00	10	3056
Se1/0	172.16.11.2	Local	172.16.11.1	2F	00	10	3055
Fa0/0	10.1.10.1	Local	10.1.10.2	2F	C0	10	15
Se1/0	172.16.11.2	Local	172.16.11.1	2F	C0	10	21
Tu0	192.168.30.1	Tu1	10.1.20.1	01	00	10	3058
Tu1	10.1.20.1	Tu0	192.168.30.1	01	00	10	3215
Tu0	192.168.20.1	Tu1	10.1.30.1	06	C0	18	21
Tu1	10.1.30.1	Tu0	192.168.20.1	06	C0	18	15

Port	Msk	AS	Port	Msk	AS	NextHop	B/Pk	Active
0000	/0	0	0000	/0	0	0.0.0.0	124	20.9
0000	/0	0	0000	/0	0	0.0.0.0	124	20.9
0000	/0	0	0000	/0	0	0.0.0.0	281	27.0
0000	/0	0	0000	/0	0	0.0.0.0	64	27.2
0000	/0	0	0000	/0	0	0.0.0.0	100	21.0
0000	/0	0	0800	/0	0	0.0.0.0	100	22.0
2AFA	/0	0	0017	/0	0	0.0.0.0	40	27.2
0017	/0	0	2AFA	/0	0	0.0.0.0	257	27.0

As is apparent, the NetFlow output did not change significantly when traffic transited between one logical interface and another. As discussed in the section on GRE tunneling, there were four NetFlow entries relating to the physical ports that terminate the tunnels. As discussed, there were four entries—even though there are only two tunnels—because the ToS bits were different. Each was treated as a separate NetFlow IP flow.

As for the actual traffic that traversed the tunnels, NetFlow cached the flows as being received on Tu0 and exiting on Tu1, and vice-versa. This was consistent with expectations.

CONCLUSION

In all test scenarios implemented, NetFlow operated properly on logical interfaces. The following chart summarizes the test results:

Test Case	Where NetFlow is Enabled:	Operated Properly	Special Considerations
Frame Relay subinterface	Frame Relay parent interface	YES	Will receive NetFlow records for all subinterfaces on the same physical interface
ATM subinterface	ATM parent interface	YES	Will receive NetFlow records for all subinterfaces on the same physical interface
ISL subinterface	ISL parent interface	YES	Will receive NetFlow records for all subinterfaces on the same physical interface
802.1q subinterface	802.1q parent interface	YES	Will receive NetFlow records for all subinterfaces on the same physical interface
Multilink PPP interface	Multilink interface	YES	None
GRE Tunnel interface	Tunnel interface	YES	Be careful about counting same packets twice. Only see ingress point of the tunnel. Enable NetFlow on tunnel peer for a complete picture.
L2TP Tunnel	Virtual-Template interface	YES	Same as GRE test case
MPLS-VPN	On interface associated with MPLS VRF	YES	Only instance where NetFlow tracks egress packets
Tunnel Hopping	Tunnel Interface	YES	Same as GRE test case

During testing, a few caveats were discovered, which are reiterated here:

- In the case of subinterfaces, NetFlow is enabled on the actual physical interface itself—not the subinterface.
- When enabling NetFlow on a physical interface, NetFlow records for all subinterfaces associated with that physical interface will be obtained.
- For logical interface types, NetFlow is enabled on the logical—not the physical—interface.
- NetFlow works in conjunction with Cisco CEF switching. When enabling NetFlow, ip cef should also be enabled.
- NetFlow always tracks flows on the ingress interface, with one exception: MPLS-VPNs, where NetFlow can be configured to track egress traffic. When tracking flows on ingress interfaces, it is usually a good idea to implement NetFlow on all interfaces of a router, in order to get a complete picture of the traffic flow.
- When the NetFlow device itself (a router, for example) is the endpoint of the traffic flow, only an ingress flow will be captured. In such cases, it may be necessary to enable NetFlow on several devices to get a complete record of traffic flow.
- In some scenarios, such as GRE, one IP flow may be encapsulated within a different IP flow. In such cases, care must be taken to avoid counting the same packets twice.
- A NetFlow IP flow is determined by a combination of the source and destination IP addresses, source and destination TCP/UDP port numbers, IP protocol type, IP Type of Service, and the input interface. If any of these factors are unique, a new IP flow record is created.

In conclusion, though this paper does not examine every type of logical interface that can be implemented on Cisco IOS Software, it reveals results of tests conducted with some common deployments. In each case, NetFlow provided consistently accurate results.

APPENDIX

Appendix A: Frame Relay Configurations and Console Output

2500 Configuration:

```
2500-NetFlow#sh run
Building configuration...
```

```
Current configuration : 589 bytes
```

```
!
version 12.1
no service single-slot-reload-enable
no service pad
service timestamps debug uptime
service timestamps log uptime
no service password-encryption
!
hostname 2500-NetFlow
!
logging rate-limit console 10 except errors
enable secret 5 $1$5790$qdhDIaRrMXMHdrmA4eFc./
!
ip subnet-zero
no ip finger
no ip domain-lookup
!
interface Ethernet0
 ip address 10.1.10.1 255.255.255.0
!
interface Serial0
 no ip address
 shutdown
!
no ip http server
ip classless
ip route 0.0.0.0 0.0.0.0 10.1.10.2
!
line con 0
 transport input none
line 1 16
line aux 0
line vty 0 4
```

```
login
```

```
!
```

```
end
```

7100 Configuration:

```
7100-NetFlow#sh run
```

```
Building configuration...
```

```
Current configuration : 1370 bytes
```

```
!
```

```
version 12.1
```

```
no service single-slot-reload-enable
```

```
service timestamps debug uptime
```

```
service timestamps log uptime
```

```
no service password-encryption
```

```
!
```

```
hostname 7100-NetFlow
```

```
!
```

```
boot system flash slot0:/c7100-js-mz.121-5.T.bin
```

```
logging rate-limit console 10 except errors
```

```
enable secret 5 $1$sL55$VzvKQXi/0SXj/V.WkqM7J1
```

```
!
```

```
ip subnet-zero
```

```
!
```

```
no ip finger
```

```
no ip domain-lookup
```

```
!
```

```
ip cef
```

```
call rsvp-sync
```

```
cns event-service server
```

```
!
```

```
interface FastEthernet0/0
```

```
ip address 10.1.10.2 255.255.255.0
```

```
duplex auto
```

```
speed 10
```

```
!
```

```
interface FastEthernet0/1
```

```
no ip address
```

```
shutdown
```

```
duplex auto
```

```
speed auto
```

```
!
interface Serial1/0
  no ip address
  framing c-bit
  cablelength 10
  dsu bandwidth 44210
!
interface Serial1/1
  ip address 172.16.10.1 255.255.255.0
  encapsulation frame-relay
  ip route-cache flow
  no keepalive
  framing c-bit
  cablelength 10
  dsu bandwidth 44210
  frame-relay map ip 172.16.10.2 17 broadcast
!
interface Serial1/1.16 point-to-point
  ip address 172.16.11.1 255.255.255.0
  frame-relay interface-dlci 16
!
interface ATM4/0
  no ip address
  shutdown
  no atm ilmi-keepalive
!
router bgp 111
  bgp log-neighbor-changes
  redistribute connected
  redistribute static
  neighbor 172.16.11.2 remote-as 222
!
ip kerberos source-interface any
ip classless
no ip http server
!
line con 0
  transport input none
line aux 0
line vty 0 4
  login
```

```
line vty 5 15
```

```
login
```

```
!
```

```
end
```

7206 Configuration:

```
7200-netflow#sh run
```

```
Building configuration...
```

```
Current configuration : 1139 bytes
```

```
!
```

```
version 12.1
```

```
service timestamps debug uptime
```

```
service timestamps log uptime
```

```
no service password-encryption
```

```
!
```

```
hostname 7200-netflow
```

```
!
```

```
boot system flash slot0:c7200-is-mz.121-5a.bin
```

```
enable secret 5 $1$LsiL$09X3YbqL7sd9o/fndrGI01
```

```
!
```

```
ip subnet-zero
```

```
ip cef
```

```
no ip finger
```

```
no ip domain-lookup
```

```
ip host PAGENT-SECURITY-V3 92.16.52.64 54.73.0.0
```

```
!
```

```
interface FastEthernet0/0
```

```
no ip address
```

```
shutdown
```

```
half-duplex
```

```
!
```

```
interface Serial3/0
```

```
ip address 172.16.10.2 255.255.255.0
```

```
encapsulation frame-relay
```

```
ip route-cache flow
```

```
no keepalive
```

```
framing c-bit
```

```
cablelength 10
```

```
dsu bandwidth 44210
```

```
frame-relay map ip 172.16.10.1 17 broadcast
```



```
!  
interface Serial3/0.16 point-to-point  
 ip address 172.16.11.2 255.255.255.0  
 frame-relay interface-dlci 16  
!  
interface FastEthernet4/0  
 ip address 192.168.10.2 255.255.255.0  
 half-duplex  
!  
router bgp 222  
 bgp log-neighbor-changes  
 redistribute connected  
 redistribute static  
 neighbor 172.16.11.1 remote-as 111  
!  
ip classless  
ip flow-export version 5 peer-as  
no ip http server  
!  
line con 0  
 exec-timeout 0 0  
 transport input none  
line aux 0  
line vty 0 4  
 login  
!  
no scheduler max-task-time  
end
```

3640 Configuration:

```
3640-NetFlow#sh run  
Building configuration...
```

```
Current configuration : 1013 bytes
```

```
!  
version 12.1  
no service single-slot-reload-enable  
service timestamps debug uptime  
service timestamps log uptime  
no service password-encryption  
!
```

```
hostname 3640-NetFlow
!
boot system flash slot0:c3640-i-mz.121-5.T.bin
logging rate-limit console 10 except errors
enable secret 5 $1$SNMK$SPKZRgaYV4UAjPZ/Ggtlh0
!
ip subnet-zero
ip cef
!
no ip finger
no ip domain-lookup
!
interface Ethernet0/0
  no ip address
  shutdown
  half-duplex
!
interface Serial0/0
  no ip address
  encapsulation lapb multi
  shutdown
!
interface Ethernet0/1
  no ip address
  shutdown
  half-duplex
!
interface FastEthernet2/0
  ip address 192.168.10.1 255.255.255.0
  duplex auto
  speed auto
!
interface Serial3/0
  no ip address
  shutdown
!
interface Serial3/1
  no ip address
  shutdown
!
interface Serial3/2
```

```

no ip address
shutdown
!
interface Serial3/3
no ip address
shutdown
!
ip classless
ip route 0.0.0.0 0.0.0.0 192.168.10.2
no ip http server
!
!
line con 0
transport input none
line aux 0
line vty 0 4
password lab
login
!
end

```

7100 Cache Output:

7100-NetFlow#sh ip cache flow

IP packet size distribution (1715 total packets):

```

1-32  64  96  128  160  192  224  256  288  320  352  384  416  448  480
.000 .204 .186 .609 .000 .000 .000 .000 .000 .000 .000 .000 .000 .000 .000

512  544  576 1024 1536 2048 2560 3072 3584 4096 4608
.000 .000 .000 .000 .000 .000 .000 .000 .000 .000 .000

```

```

IP Flow Switching Cache, 4456704 bytes
2 active, 65534 inactive, 9 added
150 ager polls, 0 flow alloc failures
Active flows timeout in 30 minutes
Inactive flows timeout in 15 seconds
last clearing of statistics 00:03:53

```

Protocol	Total Flows	Flows /Sec	Packets /Flow	Bytes /Pkt	Packets /Sec	Active(Sec) /Flow	Idle(Sec) /Flow
TCP-Telnet	4	0.0	14	41	0.2	3.8	15.5
ICMP	3	0.0	550	87	7.1	2.8	15.3
Total:	7	0.0	243	85	7.4	3.4	15.4

SrcIf	SrcIPAddress	DstIf	DstIPAddress	Pr	SrcP	DstP	Pkts
Se1/1.16	192.168.10.1	Fa0/0	10.1.10.1	01	0000	0000	5
Se1/1.16	192.168.10.1	Fa0/0	10.1.10.1	06	2AFF	0017	4

7206 Cache Output:

7200-netflow#sh ip cache flow

IP packet size distribution (1693 total packets):

1-32	64	96	128	160	192	224	256	288	320	352	384	416	448	480
.000	.190	.190	.615	.000	.000	.000	.000	.000	.000	.000	.000	.000	.000	.000
512	544	576	1024	1536	2048	2560	3072	3584	4096	4608				
.000	.000	.003	.000	.000	.000	.000	.000	.000	.000	.000				

IP Flow Switching Cache, 4456704 bytes

2 active, 65534 inactive, 7 added

120 ager polls, 0 flow alloc failures

Active flows timeout in 30 minutes

Inactive flows timeout in 15 seconds

last clearing of statistics 00:03:18

Protocol	Total	Flows	Packets	Bytes	Packets	Active(Sec)	Idle(Sec)
-----	Flows	/Sec	/Flow	/Pkt	/Sec	/Flow	/Flow
TCP-Telnet	3	0.0	12	106	0.1	4.2	15.8
ICMP	2	0.0	500	100	5.2	2.6	15.4
Total:	5	0.0	207	100	5.4	3.6	15.6

SrcIf	SrcIPAddress	DstIf	DstIPAddress	Pr	SrcP	DstP	Pkts
Se3/0.16	10.1.10.1	Fa4/0	192.168.10.1	01	0000	0800	650
Se3/0.16	10.1.10.1	Fa4/0	192.168.10.1	06	0017	2AFF	6

Appendix B: ATM Configurations and Console Output

2500 Configuration:

2500-NetFlow#sh run

Building configuration...

Current configuration : 603 bytes

!

version 12.1

no service single-slot-reload-enable

no service pad

service timestamps debug uptime

service timestamps log uptime

no service password-encryption

```
!
hostname 2500-NetFlow
!
logging rate-limit console 10 except errors
enable secret 5 $1$5790$qdhdIaRrMXMHdrmA4eFc./
!
ip subnet-zero
no ip finger
no ip domain-lookup
!
interface Ethernet0
 ip address 10.1.10.1 255.255.255.0
!
interface Serial0
 no ip address
 shutdown
!
no ip http server
ip classless
ip route 0.0.0.0 0.0.0.0 10.1.10.2
!
line con 0
 transport input none
line 1 16
line aux 0
line vty 0 4
 password lab
 login
!
end
```

7100 Configuration:

```
7100-NetFlow#sh run
Building configuration...
```

Current configuration:

```
!
version 12.1
service timestamps debug uptime
service timestamps log uptime
no service password-encryption
```

```
!
hostname 7100-NetFlow
!
boot system flash slot0:/c7100-js-mz.121-5.T.bin
enable secret 5 $1$sL55$VzvKQXi/0SXj/V.WkqM7J1
!
ip subnet-zero
no ip finger
no ip domain-lookup
!
ip cef
cns event-service server
!
interface FastEthernet0/0
 ip address 10.1.10.2 255.255.255.0
 ip route-cache flow
 duplex auto
 speed 10
!
interface FastEthernet0/1
 no ip address
 shutdown
 duplex auto
 speed auto
!
interface Serial11/0
 no ip address
 shutdown
 framing c-bit
 cablelength 10
 dsu bandwidth 44210
!
interface Serial11/1
 no ip address
 no keepalive
 shutdown
 framing c-bit
 cablelength 10
 dsu bandwidth 44210
!
interface ATM4/0
```

```
no ip address
ip route-cache flow
atm clock INTERNAL
no atm ilmi-keepalive
!
interface ATM4/0.1 point-to-point
ip address 172.16.11.1 255.255.255.0
pvc 4/40
encapsulation aal5snap
!
!
router bgp 111
bgp log-neighbor-changes
redistribute connected
redistribute static
neighbor 172.16.11.2 remote-as 222
!
ip classless
no ip http server
!
map-list atm-in
ip 172.16.11.2 atm-vc 1 broadcast
!
line con 0
transport input none
line aux 0
line vty 0 4
password lab
login
line vty 5 15
login
!
end
```

7206 Configuration:

```
7200-netflow#sh run
Building configuration...
```

```
Current configuration : 1225 bytes
```

```
!
version 12.1
```

```
service timestamps debug uptime
service timestamps log uptime
no service password-encryption
!
hostname 7200-netflow
!
boot system flash slot0:c7200-is-mz.121-5a.bin
enable secret 5 $1$LsiL$09X3YbqL7sd9o/fndrGI01
!
ip subnet-zero
no ip finger
no ip domain-lookup
ip host PAGENT-SECURITY-V3 92.16.52.64 54.73.0.0
!
ip cef
!
interface FastEthernet0/0
  no ip address
  shutdown
  half-duplex
!
interface ATM1/0
  no ip address
  ip route-cache flow
  no atm ilmi-keepalive
!
interface ATM1/0.1 point-to-point
  ip address 172.16.11.2 255.255.255.0
  pvc 4/40
    encapsulation aal5snap
!
!
interface Serial2/0
  no ip address
  shutdown
  framing c-bit
  cablelength 10
  dsu bandwidth 44210
!
interface Serial3/0
  no ip address
```



```
no keepalive
shutdown
framing c-bit
cablelength 10
dsu bandwidth 44210
!
interface FastEthernet4/0
 ip address 192.168.10.2 255.255.255.0
 ip route-cache flow
 half-duplex
!
router bgp 222
 bgp log-neighbor-changes
 redistribute connected
 redistribute static
 neighbor 172.16.11.1 remote-as 111
!
ip classless
ip flow-export version 5 peer-as
no ip http server
!
line con 0
 exec-timeout 0 0
 transport input none
line aux 0
line vty 0 4
 login
!
no scheduler max-task-time
end
```

3640 Configuration:

```
3640-NetFlow#sh run
Building configuration...
```

```
Current configuration : 1047 bytes
```

```
!
version 12.1
no service single-slot-reload-enable
service timestamps debug uptime
service timestamps log uptime
```

```
no service password-encryption
!
hostname 3640-NetFlow
!
boot system flash slot0:c3640-i-mz.121-5.T.bin
logging rate-limit console 10 except errors
enable secret 5 $1$SNMK$SPKZRgaYV4UAjPZ/Ggtlh0
!
ip subnet-zero
ip cef
!
no ip finger
no ip domain-lookup
!
interface Ethernet0/0
  no ip address
  shutdown
  half-duplex
!
interface Serial0/0
  no ip address
  encapsulation lapb multi
  shutdown
  no fair-queue
!
interface Ethernet0/1
  no ip address
  shutdown
  half-duplex
!
interface FastEthernet2/0
  ip address 192.168.10.1 255.255.255.0
  duplex auto
  speed auto
!
interface Serial3/0
  no ip address
  shutdown
  clockrate 64000
!
interface Serial3/1
```

```

no ip address
shutdown
!
interface Serial3/2
no ip address
shutdown
!
interface Serial3/3
no ip address
shutdown
!
ip classless
ip route 0.0.0.0 0.0.0.0 192.168.10.2
no ip http server
!
line con 0
transport input none
line aux 0
line vty 0 4
password lab
login
!
end

```

7206 Console Output:

```
7200-netflow#sh ip cache flow
```

```
IP packet size distribution (2035 total packets):
```

1-32	64	96	128	160	192	224	256	288	320	352	384	416	448	480
.000	.059	.000	.936	.000	.000	.000	.000	.000	.000	.000	.000	.000	.000	.001
512	544	576	1024	1536	2048	2560	3072	3584	4096	4608				
.000	.000	.001	.000	.000	.000	.000	.000	.000	.000	.000				

```

IP Flow Switching Cache, 4456704 bytes
4 active, 65532 inactive, 14 added
247 ager polls, 0 flow alloc failures
Active flows timeout in 30 minutes
Inactive flows timeout in 15 seconds
last clearing of statistics never

```

Protocol	Total	Flows	Packets	Bytes	Packets	Active(Sec)	Idle(Sec)
-----	Flows	/Sec	/Flow	/Pkt	/Sec	/Flow	/Flow
TCP-Telnet	8	0.0	15	58	0.0	7.5	15.4
TCP-BGP	1	0.0	1	44	0.0	0.0	15.3
ICMP	1	0.0	14	100	0.0	7.3	15.9
Total:	10	0.0	13	62	0.1	6.7	15.4

SrcIf	SrcIPaddress	DstIf	DstIPaddress	Pr	SrcP	DstP	Pkts
AT1/0.1	10.1.10.1	Fa4/0	192.168.10.1	01	0000	0800	1131
Fa4/0	192.168.10.1	AT1/0.1	10.1.10.1	01	0000	0000	1131

SrcIf	SrcIPaddress	DstIf	DstIPaddress	Pr	SrcP	DstP	Pkts
Fa4/0	192.168.10.1	AT1/0.1	10.1.10.1	06	2AF8	0017	3
AT1/0.1	10.1.10.1	Fa4/0	192.168.10.1	06	0017	2AF8	3

7200-netflow#sh ip cache verbose flow

IP packet size distribution (3437 total packets):

1-32	64	96	128	160	192	224	256	288	320	352	384	416	448	480
.000	.035	.000	.962	.000	.000	.000	.000	.000	.000	.000	.000	.000	.000	.000

512	544	576	1024	1536	2048	2560	3072	3584	4096	4608
.000	.000	.000	.000	.000	.000	.000	.000	.000	.000	.000

IP Flow Switching Cache, 4456704 bytes

4 active, 65532 inactive, 14 added

263 ager polls, 0 flow alloc failures

Active flows timeout in 30 minutes

Inactive flows timeout in 15 seconds

last clearing of statistics never

Protocol	Total	Flows	Packets	Bytes	Packets	Active(Sec)	Idle(Sec)
-----	Flows	/Sec	/Flow	/Pkt	/Sec	/Flow	/Flow
TCP-Telnet	8	0.0	15	58	0.0	7.5	15.4
TCP-BGP	1	0.0	1	44	0.0	0.0	15.3
ICMP	1	0.0	14	100	0.0	7.3	15.9
Total:	10	0.0	13	62	0.1	6.7	15.4

SrcIf	SrcIPaddress	DstIf	DstIPaddress	Pr	TOS	Flgs	Pkts
Port Msk AS		Port Msk AS	NextHop			B/Pk	Active
AT1/0.1	10.1.10.1	Fa4/0	192.168.10.1	01	00	10	1833

SrcIf	SrcIPAddress	DstIf	DstIPAddress	Pr	TOS	Flgs	Pkts
Port Msk AS		Port Msk AS	NextHop			B/Pk	Active
0000 /0 0		0800 /0 0	0.0.0.0			100	10.7
Fa4/0	192.168.10.1	AT1/0.1	10.1.10.1	01	00	10	1997
0000 /0 0		0000 /0 0	0.0.0.0			100	11.6
Fa4/0	192.168.10.1	AT1/0.1	10.1.10.1	06	C0	18	3
2AF8 /0 0		0017 /0 0	0.0.0.0			40	0.3
AT1/0.1	10.1.10.1	Fa4/0	192.168.10.1	06	C0	18	3
0017 /0 0		2AF8 /0 0	0.0.0.0			362	0.1

Appendix C: ISL Configurations and Console Output

2500 Configuration:

2500-NetFlow#sh run

Building configuration...

Current configuration : 749 bytes

```

!
version 12.1
no service single-slot-reload-enable
no service pad
service timestamps debug uptime
service timestamps log uptime
no service password-encryption
!
hostname 2500-NetFlow
!
logging rate-limit console 10 except errors
enable secret 5 $1$82e6$7Dn5eXb/eKfmeteFDPL4s/
!
ip subnet-zero
no ip finger
no ip domain-lookup
!
interface Ethernet0
 no ip address
 shutdown
!
interface Serial0
 ip address 10.1.10.1 255.255.255.0
!
no ip http server

```

```
ip classless
ip route 172.16.10.0 255.255.255.0 10.1.10.2
ip route 192.168.10.0 255.255.255.0 10.1.10.2 2
ip route 192.168.11.0 255.255.255.0 10.1.10.2 2
!
line con 0
  session-timeout 30
  exec-timeout 30 0
  transport input none
line 1 16
line aux 0
line vty 0 4
  password lab
  login
!
end
```

7140 Configuration:

```
7100-NetFlow#sh run
Building configuration...
```

Current configuration:

```
!
version 12.1
service timestamps debug uptime
service timestamps log uptime
no service password-encryption
!
hostname 7100-NetFlow
!
enable secret 5 $1$gPlv$88wlang25SKOiRmZxgBjf0
!
ip subnet-zero
no ip domain-lookup
!
cns event-service server
!
interface FastEthernet0/0
  ip address 172.16.10.2 255.255.255.0
  duplex auto
  speed auto
```

```
!
interface FastEthernet0/1
  no ip address
  ip route-cache flow
  duplex auto
  speed auto
!
interface FastEthernet0/1.1
  encapsulation isl 1
  ip address 192.168.10.1 255.255.255.0
  no ip redirects
!
interface FastEthernet0/1.2
  encapsulation isl 2
  ip address 192.168.11.1 255.255.255.0
  no ip redirects
!
interface Serial1/0
  no ip address
  shutdown
  framing c-bit
  cablelength 10
  dsu bandwidth 44210
!
interface Serial1/1
  no ip address
  shutdown
  framing c-bit
  cablelength 10
  dsu bandwidth 44210
!
interface ATM4/0
  no ip address
  shutdown
  no atm ilmi-keepalive
!
ip classless
ip route 10.1.10.0 255.255.255.0 172.16.10.1
ip flow-export version 5
no ip http server
!
```

```
line con 0
  session-timeout 30
  exec-timeout 30 0
  transport input none
line aux 0
line vty 0 4
  password lab
  login
!
end
```

7206 Configuration:

```
7206-NetFlow#sh run
Building configuration...
```

```
Current configuration : 1246 bytes
```

```
!
version 12.1
service timestamps debug uptime
service timestamps log uptime
no service password-encryption
!
hostname 7206-NetFlow
!
enable secret 5 $1$nP0o$b3aY8J2vAabcnXkg1ePsj.
!
ip subnet-zero
no ip finger
no ip domain-lookup
!
interface FastEthernet0/0
  no ip address
  ip route-cache flow
  half-duplex
!
interface FastEthernet0/0.1
  encapsulation isl 1
  ip address 192.168.10.2 255.255.255.0
  no ip redirects
!
interface FastEthernet0/0.2
```



```
encapsulation isl 2
ip address 192.168.11.2 255.255.255.0
no ip redirects
!
interface ATM1/0
no ip address
shutdown
no atm ilmi-keepalive
!
interface Serial2/0
no ip address
shutdown
framing c-bit
cablelength 10
dsu bandwidth 44210
!
interface Serial3/0
no ip address
shutdown
framing c-bit
cablelength 10
dsu bandwidth 44210
!
interface FastEthernet4/0
no ip address
shutdown
half-duplex
!
ip classless
ip route 10.1.10.0 255.255.255.0 192.168.10.1
ip route 10.1.10.0 255.255.255.0 192.168.11.1
ip route 172.16.10.0 255.255.255.0 192.168.11.1
ip route 172.16.10.0 255.255.255.0 192.168.10.1
ip flow-export version 5
no ip http server
!
line con 0
session-timeout 30
exec-timeout 30 0
transport input none
line aux 0
```

```
line vty 0 4
 password lab
 login
 !
end
```

3640 Configuration:

```
3640-NetFlow#sh run
Building configuration...
```

```
Current configuration : 1075 bytes
!
version 12.1
no service single-slot-reload-enable
service timestamps debug uptime
service timestamps log uptime
no service password-encryption
!
hostname 3640-NetFlow
!
logging rate-limit console 10 except errors
enable secret 5 $1$j1K.$1goM8tHXR9C0wMcfhvUOE.
!
ip subnet-zero
!
no ip finger
no ip domain-lookup
!
interface Ethernet0/0
 no ip address
 shutdown
 half-duplex
!
interface Serial0/0
 no ip address
 shutdown
 no fair-queue
!
interface Ethernet0/1
 no ip address
 shutdown
```

```
half-duplex
!
interface FastEthernet2/0
 ip address 172.16.10.1 255.255.255.0
 duplex auto
 speed auto
!
interface Serial3/0
 ip address 10.1.10.2 255.255.255.0
 clockrate 64000
!
interface Serial3/1
 no ip address
 shutdown
!
interface Serial3/2
 no ip address
 shutdown
!
interface Serial3/3
 no ip address
 shutdown
!
ip classless
ip route 192.168.10.0 255.255.255.0 172.16.10.2
ip route 192.168.11.0 255.255.255.0 172.16.10.2
no ip http server
!
line con 0
 session-timeout 30
 exec-timeout 30 0
 transport input none
line aux 0
line vty 0 4
 password lab
 login
!
end
```

7140 NetFlow Output:

7100-NetFlow#sh ip cache verbose flow

IP packet size distribution (35680 total packets):

1-32	64	96	128	160	192	224	256	288	320	352	384	416	448	480
.000	.032	.031	.936	.000	.000	.000	.000	.000	.000	.000	.000	.000	.000	.000
512	544	576	1024	1536	2048	2560	3072	3584	4096	4608				
.000	.000	.000	.000	.000	.000	.000	.000	.000	.000	.000	.000	.000	.000	.000

IP Flow Switching Cache, 4456704 bytes

3 active, 65533 inactive, 30 added
 841 ager polls, 0 flow alloc failures
 Active flows timeout in 30 minutes
 Inactive flows timeout in 15 seconds
 last clearing of statistics never

Protocol	Total	Flows	Packets	Bytes	Packets	Active(Sec)	Idle(Sec)
-----	Flows	/Sec	/Flow	/Pkt	/Sec	/Flow	/Flow
TCP-Telnet	16	0.0	11	61	0.0	7.3	13.8
ICMP	11	0.0	3109	97	5.8	28.0	15.3
Total:	27	0.0	1273	97	5.9	15.8	14.4

SrcIf	SrcIPAddress	DstIf	DstIPAddress	Pr	TOS	Flgs	Pkts
Port Msk AS		Port Msk AS	NextHop			B/Pk	Active
Fa0/0	10.1.10.1	Fa0/1.2	192.168.11.2	01	00	10	853
0000 /0 0		0800 /0 0	0.0.0.0			100	4.5

SrcIf	SrcIPAddress	DstIf	DstIPAddress	Pr	TOS	Flgs	Pkts
Port Msk AS		Port Msk AS	NextHop			B/Pk	Active
Fa0/1.2	192.168.11.2	Fa0/0	10.1.10.1	01	00	10	427
0000 /0 0		0000 /0 0	0.0.0.0			100	4.5
Fa0/1.1	192.168.11.2	Fa0/0	10.1.10.1	01	00	10	492
0000 /0 0		0000 /0 0	0.0.0.0			100	5.2

7100-NetFlow#sh ip cache verbose flow

IP packet size distribution (42536 total packets):

1-32	64	96	128	160	192	224	256	288	320	352	384	416	448	480
.000	.027	.026	.945	.000	.000	.000	.000	.000	.000	.000	.000	.000	.000	.000
512	544	576	1024	1536	2048	2560	3072	3584	4096	4608				
.000	.000	.000	.000	.000	.000	.000	.000	.000	.000	.000	.000	.000	.000	.000

IP Flow Switching Cache, 4456704 bytes
 6 active, 65530 inactive, 33 added
 930 aged polls, 0 flow alloc failures
 Active flows timeout in 30 minutes
 Inactive flows timeout in 15 seconds
 last clearing of statistics never

Protocol	Total	Flows	Packets	Bytes	Packets	Active(Sec)	Idle(Sec)
-----	Flows	/Sec	/Flow	/Pkt	/Sec	/Flow	/Flow
TCP-Telnet	16	0.0	11	61	0.0	7.3	13.8
ICMP	11	0.0	3109	97	5.8	28.0	15.3
Total:	27	0.0	1273	97	5.8	15.8	14.4

SrcIf	SrcIPAddress	DstIf	DstIPAddress	Pr	TOS	Flgs	Pkts	Port	Msk
AS	Port	Msk	AS	NextHop	B/Pk	Active			
Fa0/0	172.16.10.1	Fa0/1.1	192.168.10.2	06	C0	18	10	2AF8	/0
0	0017	/0	0	0.0.0.0	40	3.8			

SrcIf	SrcIPAddress	DstIf	DstIPAddress	Pr	TOS	Flgs	Pkts	Port	Msk
AS	Port	Msk	AS	NextHop	B/Pk	Active			
Fa0/1.1	192.168.10.2	Fa0/0	172.16.10.1	06	C0	18	4	0017	/0
0	2AF8	/0	0	0.0.0.0	282	2.6			
Fa0/1.2	192.168.10.2	Fa0/0	172.16.10.1	06	C0	18	4	0017	/0
0	2AF8	/0	0	0.0.0.0	203	3.7			
Fa0/0	10.1.10.1	Fa0/1.2	192.168.11.2	01	00	10	4412	0000	/0
0	0800	/0	0	0.0.0.0	100	23.5			
Fa0/1.2	192.168.11.2	Fa0/0	10.1.10.1	01	00	10	2206	0000	/0
0	0000	/0	0	0.0.0.0	100	23.5			
Fa0/1.1	192.168.11.2	Fa0/0	10.1.10.1	01	00	10	2206	0000	/0
0	0000	/0	0	0.0.0.0	100	23.5			

7100-NetFlow#sh ip cache flo
 7100-NetFlow#sh ip cache flow

IP packet size distribution (46915 total packets):

1-32	64	96	128	160	192	224	256	288	320	352	384	416	448	480
.000	.025	.023	.950	.000	.000	.000	.000	.000	.000	.000	.000	.000	.000	.000
512	544	576	1024	1536	2048	2560	3072	3584	4096	4608				
.000	.000	.000	.000	.000	.000	.000	.000	.000	.000	.000				

IP Flow Switching Cache, 4456704 bytes
 5 active, 65531 inactive, 35 added

991 ager polls, 0 flow alloc failures

Active flows timeout in 30 minutes

Inactive flows timeout in 15 seconds

last clearing of statistics never

Protocol	Total	Flows	Packets	Bytes	Packets	Active(Sec)	Idle(Sec)
-----	Flows	/Sec	/Flow	/Pkt	/Sec	/Flow	/Flow
TCP-Telnet	19	0.0	10	67	0.0	6.7	14.0
ICMP	11	0.0	3109	97	5.8	28.0	15.3
Total:	30	0.0	1146	97	5.8	14.5	14.5

SrcIf	SrcIPAddress	DstIf	DstIPAddress	Pr	SrcP	DstP	Pkts
Fa0/0	172.16.10.1	Fa0/1.1	192.168.10.2	06	2AF8	0017	2
Fa0/1.2	192.168.10.2	Fa0/0	172.16.10.1	06	0017	2AF8	1
Fa0/0	10.1.10.1	Fa0/1.2	192.168.11.2	01	0000	0800	6459

SrcIf	SrcIPAddress	DstIf	DstIPAddress	Pr	SrcP	DstP	Pkts
Fa0/1.2	192.168.11.2	Fa0/0	10.1.10.1	01	0000	0000	3230
Fa0/1.1	192.168.11.2	Fa0/0	10.1.10.1	01	0000	0000	5000

Appendix D: 802.1q Configurations and Console Output

2500 Configuration:

```
2500-NetFlow#sh run
```

```
Building configuration...
```

```
Current configuration : 749 bytes
```

```
!
```

```
version 12.1
```

```
no service single-slot-reload-enable
```

```
no service pad
```

```
service timestamps debug uptime
```

```
service timestamps log uptime
```

```
no service password-encryption
```

```
!
```

```
hostname 2500-NetFlow
```

```
!
```

```
logging rate-limit console 10 except errors
```

```
enable secret 5 $1$82e6$7Dn5eXb/eKfmeteFDPL4s/
```

```
!
```

```
ip subnet-zero
```

```
no ip finger
```

```
no ip domain-lookup
```

```
!  
interface Ethernet0  
  no ip address  
  shutdown  
!  
interface Serial0  
  ip address 10.1.10.1 255.255.255.0  
!  
no ip http server  
ip classless  
ip route 172.16.10.0 255.255.255.0 10.1.10.2  
ip route 192.168.10.0 255.255.255.0 10.1.10.2 2  
ip route 192.168.11.0 255.255.255.0 10.1.10.2 2  
!  
line con 0  
  session-timeout 30  
  exec-timeout 30 0  
  transport input none  
line 1 16  
line aux 0  
line vty 0 4  
  password lab  
  login  
!  
end
```

7140 Configuration:

```
7100-NetFlow#sh run  
Building configuration...
```

Current configuration:

```
!  
version 12.1  
service timestamps debug uptime  
service timestamps log uptime  
no service password-encryption  
!  
hostname 7100-NetFlow  
!  
enable secret 5 $1$gPlv$88w1ang25SKOiRmZxgBjf0  
!
```

```
ip subnet-zero
no ip domain-lookup
!
ip cef
cns event-service server
!
interface FastEthernet0/0
 ip address 172.16.10.2 255.255.255.0
 ip route-cache flow
 duplex auto
 speed auto
!
interface FastEthernet0/1
 no ip address
 ip route-cache flow
 duplex auto
 speed auto
!
interface FastEthernet0/1.1
 encapsulation dot1Q 3
 ip address 192.168.10.1 255.255.255.0
 no ip redirects
!
interface FastEthernet0/1.2
 encapsulation dot1Q 2
 ip address 192.168.11.1 255.255.255.0
 no ip redirects
!
interface Serial1/0
 no ip address
 shutdown
 framing c-bit
 cablelength 10
 dsu bandwidth 44210
!
interface Serial1/1
 no ip address
 shutdown
 framing c-bit
 cablelength 10
 dsu bandwidth 44210
```



```
!  
interface ATM4/0  
  no ip address  
  shutdown  
  no atm ilmi-keepalive  
!  
ip classless  
ip route 10.1.10.0 255.255.255.0 172.16.10.1  
ip flow-export version 5  
no ip http server  
!  
line con 0  
  session-timeout 30  
  exec-timeout 30 0  
  transport input none  
line aux 0  
line vty 0 4  
  password lab  
  login  
!  
end
```

7206 Configuration:

```
7206-NetFlow#sh run  
Building configuration...
```

```
Current configuration : 1442 bytes
```

```
!  
version 12.1  
no service single-slot-reload-enable  
service timestamps debug uptime  
service timestamps log uptime  
no service password-encryption  
!  
hostname 7206-NetFlow  
!  
logging rate-limit console 10 except errors  
enable secret 5 $1$nP0o$b3aY8J2vAabcnXkg1ePsj.  
!  
ip subnet-zero  
!
```

```
no ip finger
no ip domain-lookup
!
ip cef
call rsvp-sync
cns event-service server
!
interface FastEthernet0/0
  no ip address
  duplex half
!
interface FastEthernet0/0.1
  encapsulation dot1Q 3
  ip address 192.168.10.2 255.255.255.0
  no ip redirects
!
interface FastEthernet0/0.2
  encapsulation dot1Q 2
  ip address 192.168.11.2 255.255.255.0
  no ip redirects
!
interface ATM1/0
  no ip address
  shutdown
  no atm ilmi-keepalive
!
interface Serial2/0
  no ip address
  shutdown
  framing c-bit
  cablelength 10
  dsu bandwidth 44210
!
interface Serial3/0
  no ip address
  shutdown
  framing c-bit
  cablelength 10
  dsu bandwidth 44210
!
interface FastEthernet4/0
```

```
no ip address
shutdown
duplex half
!
ip kerberos source-interface any
ip classless
ip route 10.1.10.0 255.255.255.0 192.168.10.1
ip route 10.1.10.0 255.255.255.0 192.168.11.1
ip route 172.16.10.0 255.255.255.0 192.168.11.1
ip route 172.16.10.0 255.255.255.0 192.168.10.1
ip flow-export version 5
no ip http server
!
gatekeeper
shutdown
!
!
line con 0
  session-timeout 30
  exec-timeout 30 0
  transport input none
line aux 0
line vty 0 4
  password lab
  login
line vty 5 15
  login
!
end
```

3640 Configuration:

```
3640-NetFlow#sh run
Building configuration...
```

```
Current configuration : 1075 bytes
!
version 12.1
no service single-slot-reload-enable
service timestamps debug uptime
service timestamps log uptime
no service password-encryption
```

```
!
hostname 3640-NetFlow
!
logging rate-limit console 10 except errors
enable secret 5 $1$j1K.$1goM8tHXR9C0wMcfhvUOE.
!
ip subnet-zero
!
no ip finger
no ip domain-lookup
!
interface Ethernet0/0
  no ip address
  shutdown
  half-duplex
!
interface Serial0/0
  no ip address
  shutdown
  no fair-queue
!
interface Ethernet0/1
  no ip address
  shutdown
  half-duplex
!
interface FastEthernet2/0
  ip address 172.16.10.1 255.255.255.0
  duplex auto
  speed auto
!
interface Serial3/0
  ip address 10.1.10.2 255.255.255.0
  clockrate 64000
!
interface Serial3/1
  no ip address
  shutdown
!
interface Serial3/2
  no ip address
```

```

shutdown
!
interface Serial3/3
  no ip address
  shutdown
!
ip classless
ip route 192.168.10.0 255.255.255.0 172.16.10.2
ip route 192.168.11.0 255.255.255.0 172.16.10.2
no ip http server
!
line con 0
  session-timeout 30
  exec-timeout 30 0
  transport input none
line aux 0
line vty 0 4
  password lab
  login
!
end

```

7140 NetFlow Output:

7100-NetFlow#sh ip cache flow

IP packet size distribution (57722 total packets):

```

  1-32  64  96 128 160 192 224 256 288 320 352 384 416 448 480
  .000 .023 .019 .956 .000 .000 .000 .000 .000 .000 .000 .000 .000 .000 .000

    512 544 576 1024 1536 2048 2560 3072 3584 4096 4608
    .000 .000 .000 .000 .000 .000 .000 .000 .000 .000 .000

```

IP Flow Switching Cache, 4456704 bytes

```

 6 active, 65530 inactive, 54 added
1418 aged polls, 0 flow alloc failures
Active flows timeout in 30 minutes
Inactive flows timeout in 15 seconds
last clearing of statistics never

```

Protocol	Total	Flows	Packets	Bytes	Packets	Active(Sec)	Idle(Sec)
-----	Flows	/Sec	/Flow	/Pkt	/Sec	/Flow	/Flow
TCP-Telnet	34	0.0	11	58	0.0	6.5	13.0
ICMP	14	0.0	3871	98	6.9	33.4	15.4
Total:	48	0.0	1137	98	7.0	14.3	13.7

SrcIf	SrcIPAddress	DstIf	DstIPAddress	Pr	SrcP	DstP	Pkts
Fa0/0	172.16.10.1	Fa0/1.1	192.168.10.2	06	2AF9	0017	3
Fa0/1.1	192.168.10.2	Fa0/0	172.16.10.1	06	0017	2AF9	2
Fa0/1.2	192.168.10.2	Fa0/0	172.16.10.1	06	0017	2AF9	2

SrcIf	SrcIPAddress	DstIf	DstIPAddress	Pr	SrcP	DstP	Pkts
Fa0/0	10.1.10.1	Fa0/1.2	192.168.11.2	01	0000	0800	1765
Fa0/1.2	192.168.11.2	Fa0/0	10.1.10.1	01	0000	0000	952
Fa0/1.1	192.168.11.2	Fa0/0	10.1.10.1	01	0000	0000	952

7100-NetFlow#sh ip cache verbose flow

IP packet size distribution (67485 total packets):

1-32	64	96	128	160	192	224	256	288	320	352	384	416	448	480
.000	.020	.016	.962	.000	.000	.000	.000	.000	.000	.000	.000	.000	.000	.000
512	544	576	1024	1536	2048	2560	3072	3584	4096	4608				
.000	.000	.000	.000	.000	.000	.000	.000	.000	.000	.000				

IP Flow Switching Cache, 4456704 bytes

6 active, 65530 inactive, 57 added

1546 ager polls, 0 flow alloc failures

Active flows timeout in 30 minutes

Inactive flows timeout in 15 seconds

last clearing of statistics never

Protocol	Total Flows	Flows /Sec	Packets /Flow	Bytes /Pkt	Packets /Sec	Active(Flow)	Idle(Flow)
TCP-Telnet	37	0.0	10	61	0.0	5.9	13.2
ICMP	14	0.0	3871	98	6.9	33.4	15.4
Total:	51	0.0	1070	98	7.0	13.5	13.8

SrcIf	SrcIPAddress	DstIf	DstIPAddress	Pr	TOS	Flgs	Pkts	Port	Msk
AS	Port Msk	AS	NextHop	B/Pk	Active				
Fa0/0	172.16.10.1	Fa0/1.1	192.168.10.2	06	C0	18	4	2AF9	/0
0	0017 /0	0	0.0.0.0	40	0.9				

SrcIf	SrcIPAddress	DstIf	DstIPAddress	Pr	TOS	Flgs	Pkts	Port	Msk
AS	Port Msk	AS	NextHop	B/Pk	Active				
Fa0/1.1	192.168.10.2	Fa0/0	172.16.10.1	06	C0	18	1	0017	/0
0	2AF9 /0	0	0.0.0.0	427	0.0				
Fa0/1.2	192.168.10.2	Fa0/0	172.16.10.1	06	C0	18	1	0017	/0

0	2AF9 /0	0	0.0.0.0	137	0.0	
Fa0/0	10.1.10.1	Fa0/1.2	192.168.11.2	01 00 10	6697 0000	/0
0	0800 /0	0	0.0.0.0	100	35.8	
Fa0/1.2	192.168.11.2	Fa0/0	10.1.10.1	01 00 10	3348 0000	/0
0	0000 /0	0	0.0.0.0	100	35.8	
Fa0/1.1	192.168.11.2	Fa0/0	10.1.10.1	01 00 10	3349 0000	/0
0	0000 /0	0	0.0.0.0	100	35.8	

Appendix E: Multilink PPP Configurations and Console Output

2500 Configuration:

2500-NetFlow#sh run

Building configuration...

Current configuration : 603 bytes

```

!
version 12.1
no service single-slot-reload-enable
no service pad
service timestamps debug uptime
service timestamps log uptime
no service password-encryption
!
hostname 2500-NetFlow
!
logging rate-limit console 10 except errors
enable secret 5 $1$5790$qdhdIaRrMXMHdrmA4eFc./
!
ip subnet-zero
no ip finger
no ip domain-lookup
!
interface Ethernet0
 ip address 10.1.10.1 255.255.255.0
!
interface Serial0
 no ip address
 shutdown
!
no ip http server
ip classless
ip route 0.0.0.0 0.0.0.0 10.1.10.2

```

```
!  
line con 0  
  transport input none  
line 1 16  
line aux 0  
line vty 0 4  
  password lab  
  login  
!  
end
```

7140 Configuration:

```
7100-NetFlow#sh run  
Building configuration...
```

Current configuration : 1603 bytes

```
!  
version 12.1  
no service single-slot-reload-enable  
service timestamps debug uptime  
service timestamps log uptime  
no service password-encryption  
!  
hostname 7100-NetFlow  
!  
boot system flash slot0:/c7100-js-mz.121-5.T.bin  
logging rate-limit console 10 except errors  
enable secret 5 $1$sL55$VzvKQXi/0SXj/V.WkqM7J1  
!  
ip subnet-zero  
!  
no ip finger  
no ip domain-lookup  
!  
ip cef  
call rsvp-sync  
cns event-service server  
!  
interface Multilink1  
  ip address 172.16.11.1 255.255.255.0  
  ip route-cache flow
```



```
ppp chap hostname 7100
ppp multilink
multilink-group 1
!
interface FastEthernet0/0
ip address 10.1.10.2 255.255.255.0
duplex auto
speed 10
!
interface FastEthernet0/1
no ip address
shutdown
duplex auto
speed auto
!
interface Serial1/0
no ip address
encapsulation ppp
ip route-cache flow
framing c-bit
cablelength 10
dsu bandwidth 44210
ppp chap hostname 7100
ppp multilink
multilink-group 1
!
interface Serial1/1
no ip address
encapsulation ppp
ip route-cache flow
no keepalive
framing c-bit
cablelength 10
dsu bandwidth 44210
ppp chap hostname 7100
ppp multilink
multilink-group 1
!
interface ATM4/0
no ip address
shutdown
```

```
atm clock INTERNAL
no atm ilmi-keepalive
!
router bgp 111
  bgp log-neighbor-changes
  redistribute connected
  redistribute static
  neighbor 172.16.11.2 remote-as 222
!
ip kerberos source-interface any
ip classless
no ip http server
!
map-list atm-in
  ip 172.16.11.2 atm-vc 1 broadcast
!
line con 0
  transport input none
line aux 0
line vty 0 4
  password lab
  login
line vty 5 15
  login
!
end
```

7206 Configuration:

```
7200-netflow#sh run
Building configuration...
```

```
Current configuration : 1432 bytes
```

```
!
version 12.1
service timestamps debug uptime
service timestamps log uptime
no service password-encryption
!
hostname 7200-netflow
!
boot system flash slot0:c7200-is-mz.121-5a.bin
```

```
enable secret 5 $1$LsiL$09X3YbqL7sd9o/fndrGI01
!
ip subnet-zero
no ip finger
no ip domain-lookup
ip host PAGENT-SECURITY-V3 92.16.52.64 54.73.0.0
!
ip cef
!
interface Multilink1
 ip address 172.16.11.2 255.255.255.0
 ip route-cache flow
 ppp chap hostname 7206
 ppp multilink
 multilink-group 1
!
interface FastEthernet0/0
 no ip address
 shutdown
 half-duplex
!
interface ATM1/0
 no ip address
 shutdown
 no atm ilmi-keepalive
!
interface Serial2/0
 no ip address
 encapsulation ppp
 ip route-cache flow
 framing c-bit
 cablelength 10
 dsu bandwidth 44210
 ppp chap hostname 7206
 ppp multilink
 multilink-group 1
!
interface Serial3/0
 no ip address
 encapsulation ppp
 ip route-cache flow
```

```
no keepalive
framing c-bit
cablelength 10
dsu bandwidth 44210
ppp chap hostname 7206
ppp multilink
multilink-group 1
!
interface FastEthernet4/0
ip address 192.168.10.2 255.255.255.0
ip route-cache flow
half-duplex
!
router bgp 222
bgp log-neighbor-changes
redistribute connected
redistribute static
neighbor 172.16.11.1 remote-as 111
!
ip classless
ip flow-export version 5 peer-as
no ip http server
!
line con 0
exec-timeout 0 0
transport input none
line aux 0
line vty 0 4
login
!
no scheduler max-task-time
end
```

3640 Configuration:

```
3640-NetFlow#sh run
Building configuration...
```

```
Current configuration : 1034 bytes
!
version 12.1
no service single-slot-reload-enable
```

```
service timestamps debug uptime
service timestamps log uptime
no service password-encryption
!
hostname 3640-NetFlow
!
boot system flash slot0:c3640-i-mz.121-5.T.bin
logging rate-limit console 10 except errors
enable secret 5 $1$SNMK$SPKZRgaYV4UAjPZ/Ggtlh0
!
ip subnet-zero
ip cef
!
no ip finger
no ip domain-lookup
!
interface Ethernet0/0
  no ip address
  shutdown
  half-duplex
!
interface Serial0/0
  no ip address
  encapsulation lapb multi
  shutdown
!
interface Ethernet0/1
  no ip address
  shutdown
  half-duplex
!
interface FastEthernet2/0
  ip address 192.168.10.1 255.255.255.0
  ip route-cache flow
  duplex auto
  speed auto
!
interface Serial3/0
  no ip address
  shutdown
!
```

```

interface Serial3/1
  no ip address
  shutdown
!
interface Serial3/2
  no ip address
  shutdown
!
interface Serial3/3
  no ip address
  shutdown
!
ip classless
ip route 0.0.0.0 0.0.0.0 192.168.10.2
no ip http server
!
line con 0
  transport input none
line aux 0
line vty 0 4
  password lab
  login
!
end

```

7206 NetFlow Output:

```
7200-netflow#sh ip cache flow
```

```
IP packet size distribution (4033 total packets):
```

1-32	64	96	128	160	192	224	256	288	320	352	384	416	448	480
.000	.023	.000	.974	.000	.000	.000	.000	.000	.000	.000	.000	.000	.000	.000
512	544	576	1024	1536	2048	2560	3072	3584	4096	4608				
.000	.000	.000	.000	.000	.000	.000	.000	.000	.000	.000				

```

IP Flow Switching Cache, 4456704 bytes
  4 active, 65532 inactive, 8 added
  152 ager polls, 0 flow alloc failures
  Active flows timeout in 30 minutes
  Inactive flows timeout in 15 seconds
  last clearing of statistics 00:02:13

```

Protocol	Total	Flows	Packets	Bytes	Packets	Active(Sec)	Idle(Sec)
-----	Flows	/Sec	/Flow	/Pkt	/Sec	/Flow	/Flow
TCP-Telnet	4	0.0	21	43	0.6	11.9	15.1
Total:	4	0.0	21	43	0.6	11.9	15.1

SrcIf	SrcIPAddress	DstIf	DstIPAddress	Pr	SrcP	DstP	Pkts
Mu1	10.1.10.1	Fa4/0	192.168.10.1	01	0000	0800	1971
Fa4/0	192.168.10.1	Mu1	10.1.10.1	01	0000	0000	2152
Mu1	10.1.10.1	Fa4/0	192.168.10.1	06	0017	2B05	8
Fa4/0	192.168.10.1	Mu1	10.1.10.1	06	2B05	0017	10

Appendix F: GRE Configurations and Console Output

2500 Configuration:

2500-NetFlow#sh run

Building configuration...

Current configuration : 603 bytes

!

version 12.1

no service single-slot-reload-enable

no service pad

service timestamps debug uptime

service timestamps log uptime

no service password-encryption

!

hostname 2500-NetFlow

!

logging rate-limit console 10 except errors

enable secret 5 \$1\$5790\$qdhDIaRrMXMHdrmA4eFc./

!

ip subnet-zero

no ip finger

no ip domain-lookup

!

interface Ethernet0

ip address 10.1.10.1 255.255.255.0

!

interface Serial0

no ip address

shutdown

!

```
no ip http server
ip classless
ip route 0.0.0.0 0.0.0.0 10.1.10.2
!
line con 0
  transport input none
line 1 16
line aux 0
line vty 0 4
  password lab
  login
!
end
```

7140 Configuration:

```
7100-NetFlow#sh run
Building configuration...
```

```
Current configuration : 1402 bytes
!
version 12.1
no service single-slot-reload-enable
service timestamps debug uptime
service timestamps log uptime
no service password-encryption
!
hostname 7100-NetFlow
!
boot system flash slot0:/c7100-js-mz.121-5.T.bin
logging rate-limit console 10 except errors
enable secret 5 $1$sL55$VzvKQXi/0SXj/V.WkqM7J1
!
ip subnet-zero
!
!
no ip finger
no ip domain-lookup
!
ip cef
call rsvp-sync
cns event-service server
```



```
!  
interface Tunnel0  
 ip address 172.16.12.1 255.255.255.0  
 ip route-cache flow  
 tunnel source 172.16.11.1  
 tunnel destination 172.16.11.2
```

```
!  
interface FastEthernet0/0  
 ip address 10.1.10.2 255.255.255.0  
 ip route-cache flow  
 duplex auto  
 speed 10
```

```
!  
interface FastEthernet0/1  
 no ip address  
 shutdown  
 duplex auto  
 speed auto
```

```
!  
interface Serial1/0  
 ip address 172.16.11.1 255.255.255.0  
 encapsulation ppp  
 ip route-cache flow  
 framing c-bit  
 cablelength 10  
 dsu bandwidth 44210  
 clock source internal
```

```
!  
interface Serial1/1  
 no ip address  
 encapsulation ppp  
 ip route-cache flow  
 shutdown  
 framing c-bit  
 cablelength 10  
 dsu bandwidth 44210
```

```
!  
interface ATM4/0  
 no ip address  
 shutdown  
 atm clock INTERNAL
```

```
no atm ilmi-keepalive
!
ip kerberos source-interface any
ip classless
ip route 192.168.10.0 255.255.255.0 Tunnel0
ip flow-export version 5
no ip http server
!
line con 0
  transport input none
line aux 0
line vty 0 4
  password lab
  login
line vty 5 15
  login
!
end
```

7206 Configuration:

```
7200-netflow#sh run
Building configuration...
```

Current configuration : 1234 bytes

```
!
version 12.1
service timestamps debug uptime
service timestamps log uptime
no service password-encryption
!
hostname 7200-netflow
!
boot system flash slot0:c7200-is-mz.121-5a.bin
enable secret 5 $1$LsiL$09X3YbqL7sd9o/fndrGI01
!
ip subnet-zero
ip cef
no ip finger
no ip domain-lookup
ip host PAGENT-SECURITY-V3 92.16.52.64 54.73.0.0
!
```

```
interface Tunnel0
 ip address 172.16.12.2 255.255.255.0
 ip route-cache flow
 tunnel source 172.16.11.2
 tunnel destination 172.16.11.1
!
interface FastEthernet0/0
 no ip address
 shutdown
 half-duplex
!
interface ATM1/0
 no ip address
 shutdown
 no atm ilmi-keepalive
!
interface Serial2/0
 ip address 172.16.11.2 255.255.255.0
 encapsulation ppp
 ip route-cache flow
 framing c-bit
 cablelength 10
 dsu bandwidth 44210
!
interface Serial3/0
 no ip address
 encapsulation ppp
 ip route-cache flow
 shutdown
 framing c-bit
 cablelength 10
 dsu bandwidth 44210
!
interface FastEthernet4/0
 ip address 192.168.10.2 255.255.255.0
 ip route-cache flow
 half-duplex
!
ip classless
ip route 10.1.10.0 255.255.255.0 Tunnel0
ip flow-export version 5
```

```
no ip http server
!  
line con 0
  exec-timeout 0 0
  transport input none
line aux 0
line vty 0 4
  login
!  
no scheduler max-task-time
end
```

3640 Configuration:

```
3640-NetFlow#sh run
Building configuration...
```

```
Current configuration : 1068 bytes
!  
version 12.1
no service single-slot-reload-enable
service timestamps debug uptime
service timestamps log uptime
no service password-encryption
!  
hostname 3640-NetFlow
!  
boot system flash slot0:c3640-i-mz.121-5.T.bin
logging rate-limit console 10 except errors
enable secret 5 $1$SNMK$SPKZRgaYV4UAjPZ/Ggt1h0
!  
ip subnet-zero
ip cef
!  
no ip finger
no ip domain-lookup
!  
interface Ethernet0/0
  no ip address
  shutdown
  half-duplex
!
```

```
interface Serial0/0
  no ip address
  encapsulation lapb multi
  shutdown
  no fair-queue
!
interface Ethernet0/1
  no ip address
  shutdown
  half-duplex
!
interface FastEthernet2/0
  ip address 192.168.10.1 255.255.255.0
  ip route-cache flow
  duplex auto
  speed auto
!
interface Serial3/0
  no ip address
  shutdown
  clockrate 64000
!
interface Serial3/1
  no ip address
  shutdown
!
interface Serial3/2
  no ip address
  shutdown
!
interface Serial3/3
  no ip address
  shutdown
!
ip classless
ip route 0.0.0.0 0.0.0.0 192.168.10.2
no ip http server
!
line con 0
  transport input none
line aux 0
```

```

line vty 0 4
 password lab
 login
!
end

```

7200 NetFlow Output:

```
7200-netflow#sh ip cache verbose flow
```

```
IP packet size distribution (18048 total packets):
```

```

 1-32  64  96 128 160 192 224 256 288 320 352 384 416 448 480
 .000 .000 .000 1.00 .000 .000 .000 .000 .000 .000 .000 .000 .000 .000 .000

 512 544 576 1024 1536 2048 2560 3072 3584 4096 4608
 .000 .000 .000 .000 .000 .000 .000 .000 .000 .000 .000

```

```

IP Flow Switching Cache, 4456704 bytes
 0 active, 65536 inactive, 9 added
 312 ager polls, 0 flow alloc failures
 Active flows timeout in 30 minutes
 Inactive flows timeout in 15 seconds
 last clearing of statistics never

```

Protocol	Total Flows	Flows /Sec	Packets /Flow	Bytes /Pkt	Packets /Sec	Active(Sec) /Flow	Idle(Sec) /Flow
ICMP	6	0.0	3008	100	15.6	18.7	15.3
GRE	3	0.0	3008	0	7.8	18.7	15.3
Total:	9	0.0	3008	66	23.5	18.7	15.3

```

SrcIf          SrcIPAddress      DstIf          DstIPAddress    Pr TOS Flgs Pkts
Port Msk AS          Port Msk AS      NextHop         B/Pk Active

```

```
7200-netflow#sh ip cache verbose flow
```

```
IP packet size distribution (19991 total packets):
```

```

 1-32  64  96 128 160 192 224 256 288 320 352 384 416 448 480
 .000 .004 .000 .994 .000 .000 .000 .000 .000 .000 .000 .000 .000 .000 .000

 512 544 576 1024 1536 2048 2560 3072 3584 4096 4608
 .000 .000 .000 .000 .000 .000 .000 .000 .000 .000 .000

```

```

IP Flow Switching Cache, 4456704 bytes
 6 active, 65530 inactive, 18 added
 433 ager polls, 0 flow alloc failures
 Active flows timeout in 30 minutes

```

Inactive flows timeout in 15 seconds

last clearing of statistics never

Protocol	Total	Flows	Packets	Bytes	Packets	Active(Sec)	Idle(Sec)
-----	Flows	/Sec	/Flow	/Pkt	/Sec	/Flow	/Flow
TCP-Telnet	2	0.0	48	91	0.0	15.5	15.6
ICMP	6	0.0	3008	100	14.9	18.7	15.3
GRE	4	0.0	2266	0	7.4	17.9	15.3
Total:	12	0.0	2267	66	22.4	17.9	15.4

SrcIf	SrcIPAddress	DstIf	DstIPAddress	Pr	TOS	Flgs	Pkts	Port	Msk
AS Port Msk AS	NextHop	B/Pk	Active						
Se2/0	172.16.11.1	Local	172.16.11.2	2F	00	10	1098	0000	/0
0 0000 /0 0	0.0.0.0	0	6.6						
Se2/0	172.16.11.1	Local	172.16.11.2	2F	C0	10	7	0000	/0
0 0000 /0 0	0.0.0.0	0	0.6						
Tu0	10.1.10.1	Fa4/0	192.168.10.1	01	00	10	1102		
0000 /0 0		0800 /0 0	0.0.0.0			100	6.6		
Fa4/0	192.168.10.1	Tu0	10.1.10.1	01	00	10	1102		
0000 /0 0		0000 /0 0	0.0.0.0			100	6.6		
Fa4/0	192.168.10.1	Tu0	10.1.10.1	06	C0	18	8		
2AF8 /0 0		0017 /0 0	0.0.0.0			40	1.1		
Tu0	10.1.10.1	Fa4/0	192.168.10.1	06	C0	18	7		
0017 /0 0		2AF8 /0 0	0.0.0.0			379	0.6		

7200-netflow#sh ip cache flow

IP packet size distribution (30443 total packets):

1-32	64	96	128	160	192	224	256	288	320	352	384	416	448	480
.000	.004	.000	.994	.000	.000	.000	.000	.000	.000	.000	.000	.000	.000	.000
512	544	576	1024	1536	2048	2560	3072	3584	4096	4608				
.000	.000	.000	.000	.000	.000	.000	.000	.000	.000	.000				

IP Flow Switching Cache, 4456704 bytes

6 active, 65530 inactive, 18 added

619 ager polls, 0 flow alloc failures

Active flows timeout in 30 minutes

Inactive flows timeout in 15 seconds

last clearing of statistics never

Protocol	Total	Flows	Packets	Bytes	Packets	Active(Sec)	Idle(Sec)
-----	Flows	/Sec	/Flow	/Pkt	/Sec	/Flow	/Flow
TCP-Telnet	2	0.0	48	91	0.0	15.5	15.6
ICMP	6	0.0	3008	100	14.5	18.7	15.3

GRE	4	0.0	2266	0	7.3	17.9	15.3
Total:	12	0.0	2267	66	21.9	17.9	15.4

SrcIf	SrcIPAddress	DstIf	DstIPAddress	Pr	SrcP	DstP	Pkts
Se2/0	172.16.11.1	Local	172.16.11.2	2F	0000	0000	6300
Se2/0	172.16.11.1	Local	172.16.11.2	2F	0000	0000	29
Tu0	10.1.10.1	Fa4/0	192.168.10.1	01	0000	0800	6305
Fa4/0	192.168.10.1	Tu0	10.1.10.1	01	0000	0000	6305
Fa4/0	192.168.10.1	Tu0	10.1.10.1	06	2AF8	0017	34
Tu0	10.1.10.1	Fa4/0	192.168.10.1	06	0017	2AF8	29

Appendix G: L2TP Configurations and Console Output

7206 Client Configuration:

```
7200-NetFlow-client#sh run
Building configuration...
```

Current configuration:

```
!
version 12.0
service timestamps debug uptime
service timestamps log uptime
no service password-encryption
!
hostname 7200-NetFlow-client
!
enable password lab
!
ip subnet-zero
!
interface Loopback0
 ip address 10.8.1.1 255.255.255.0
 no ip directed-broadcast
!
interface FastEthernet0/0
 ip address 10.2.1.2 255.255.255.0
 no ip directed-broadcast
!
interface Serial2/0
 no ip address
 no ip directed-broadcast
 no ip mroute-cache
```



```
shutdown
no fair-queue
!
interface Serial2/1
no ip address
no ip directed-broadcast
shutdown
!
interface Serial2/2
no ip address
no ip directed-broadcast
shutdown
!
interface Serial2/3
no ip address
no ip directed-broadcast
shutdown
!
interface FastEthernet4/0
no ip address
no ip directed-broadcast
shutdown
!
interface Serial6/0
no ip address
no ip directed-broadcast
shutdown
!
interface Serial6/1
no ip address
no ip directed-broadcast
shutdown
!
interface Serial6/2
no ip address
no ip directed-broadcast
shutdown
!
interface Serial6/3
no ip address
no ip directed-broadcast
```

```
shutdown
!
ip default-gateway 10.2.1.1
ip classless
ip route 0.0.0.0 0.0.0.0 10.2.1.1
no ip http server
!
line con 0
  transport input none
line aux 0
line vty 0 4
  password lab
  login
!
end
```

7206 LAC Configuration:

```
lacl#sh run
Building configuration...
```

Current configuration:

```
!
version 12.1
service timestamps debug uptime
service timestamps log uptime
no service password-encryption
service internal
!
hostname lacl
!
enable secret 5 $1$nP0o$b3aY8J2vAabcnXkglePsj.
!
username lacl password 0 cisco
username lns1 password 0 cisco
!
ip subnet-zero
ip cef
no ip finger
no ip domain-lookup
ip host PAGENT-SECURITY-V3 11.81.82.4 75.87.0.0
!
```

```
vpdn enable
no vpdn logging
!
vpdn-group 1
  request-dialin
  protocol l2tp
  pool-member 2
  initiate-to ip 10.3.1.2 priority 1
  local name lacl
  l2tp tunnel hello 0
  scalability virtual-template 1
  scalability one-session-per-tunnel
!
interface FastEthernet0/0
  ip address 10.2.1.1 255.255.255.0
  no keepalive
  half-duplex
!
interface ATM1/0
  no ip address
  shutdown
  no atm ilmi-keepalive
!
interface Serial2/0
  no ip address
  shutdown
  framing c-bit
  cablelength 10
  dsu bandwidth 44210
!
interface Serial3/0
  no ip address
  shutdown
  framing c-bit
  cablelength 10
  dsu bandwidth 44210
!
interface FastEthernet4/0
  ip address 10.3.1.1 255.255.255.0
  full-duplex
!
```

```
interface Virtual-Template1
 ip address negotiated
 ip mroute-cache
 no keepalive
 no peer default ip address
 ppp authentication chap
!
interface Dialer2
 ip address 15.1.0.1 255.0.0.0
 encapsulation ppp
 no logging event link-status
 no keepalive
 dialer remote-name lns1
 dialer pool 2
 dialer idle-timeout 2147483
 dialer string 12345
 dialer max-call 4096
 dialer vpdn scalability
 dialer-group 1
 no fair-queue
 pulse-time 0
 no cdp enable
 ppp authentication chap
!
ip classless
ip route 10.8.1.0 255.255.255.0 10.2.1.2
ip route 15.1.0.0 255.255.0.0 Dialer2
ip flow-export version 5
no ip http server
!
dialer-list 1 protocol ip permit
!
line con 0
 session-timeout 30
 exec-timeout 30 0
 transport input none
line aux 0
line vty 0 4
 password lab
```

```
login
```

```
!
```

```
end
```

7500 LNS Configuration:

```
lns1#sh run
```

```
Building configuration...
```

```
Current configuration : 1946 bytes
```

```
!
```

```
version 12.1
```

```
no service pad
```

```
service timestamps debug uptime
```

```
service timestamps log uptime
```

```
no service password-encryption
```

```
no service dhcp
```

```
!
```

```
hostname lns1
```

```
!
```

```
boot system slot0:rsp-jsv-mz.121-4.4.T
```

```
!
```

```
username lac1 password 0 cisco
```

```
username lns1 password 0 cisco
```

```
username lac2 password 0 cisco
```

```
!
```

```
ip subnet-zero
```

```
no ip finger
```

```
no ip domain-lookup
```

```
!
```

```
ip cef
```

```
vpdn enable
```

```
no vpdn logging
```

```
!
```

```
vpdn-group 1
```

```
! Default L2TP VPDN group
```

```
accept-dialin
```

```
protocol l2tp
```

```
virtual-template 1
```

```
local name lns1
```

```
lcp renegotiation always
```

```
!
```

```
cns event-service server
!
interface Loopback0
 ip address 1.0.0.1 255.0.0.0
!
interface FastEthernet0/0/0
 ip address 10.4.1.2 255.255.255.0
 no ip route-cache distributed
 full-duplex
!
interface FastEthernet0/1/0
 ip address 10.3.1.2 255.255.255.0
 ip route-cache flow
 no ip route-cache distributed
 full-duplex
!
interface FastEthernet4/0/0
 mac-address 0000.2222.0000
 ip address 10.5.1.1 255.255.255.0
 ip load-sharing per-packet
 no ip route-cache distributed
 no keepalive
 full-duplex
!
interface FastEthernet4/1/0
 mac-address 0000.3333.0000
 ip address 10.6.1.1 255.255.255.0
 ip load-sharing per-packet
 ip route-cache flow
 no ip route-cache distributed
 half-duplex
!
interface Virtual-Template1
 ip unnumbered Loopback0
 ip route-cache flow
 load-interval 30
 no keepalive
 peer default ip address pool vpdn
 ppp authentication chap
!
ip local pool vpdn 5.1.0.1 5.1.7.208
```

```
ip kerberos source-interface any
ip classless
ip route 10.2.1.0 255.255.255.0 Virtual-Template1
ip route 10.2.1.0 255.255.255.0 5.1.0.1
ip route 10.8.1.0 255.255.255.0 5.1.0.2
ip route 15.1.0.0 255.255.0.0 10.6.1.2
ip route 15.2.254.0 255.255.255.0 10.6.1.2
ip route 20.1.0.0 255.255.0.0 10.6.1.2
ip route 20.1.0.0 255.255.0.0 10.5.1.2
no ip http server
!
alias exec ss show vpdn session | include L2TP
alias exec scp show proc cpu | include CPU
!
line con 0
  exec-timeout 0 0
  transport input none
line aux 0
line vty 0 4
  login
!
end
```

3640 Client Configuration:

```
3640-NetFlow#sh run
Building configuration...
```

```
Current configuration : 1118 bytes
!
version 12.1
no service single-slot-reload-enable
service timestamps debug uptime
service timestamps log uptime
no service password-encryption
!
hostname 3640-NetFlow
!
logging rate-limit console 10 except errors
enable secret 5 $1$j1k.$1goM8tHXR9C0wMcfhvUOE.
!
ip subnet-zero
```

```
!
no ip finger
no ip domain-lookup
!
interface Loopback0
 ip address 15.1.254.254 255.255.0.0
!
interface Loopback1
 ip address 15.2.254.254 255.255.255.0
!
interface Ethernet0/0
 no ip address
 shutdown
 half-duplex
!
interface Serial0/0
 no ip address
 shutdown
 no fair-queue
!
interface Ethernet0/1
 no ip address
 shutdown
 half-duplex
!
interface FastEthernet2/0
 ip address 10.6.1.2 255.255.255.0
 speed auto
 half-duplex
!
interface Serial3/0
 no ip address
!
interface Serial3/1
 no ip address
 shutdown
!
interface Serial3/2
 no ip address
 shutdown
!
```



```

interface Serial3/3
  no ip address
  shutdown
!
ip default-gateway 10.6.1.1
ip classless
ip route 0.0.0.0 0.0.0.0 10.6.1.1
no ip http server
!
line con 0
  session-timeout 30
  exec-timeout 30 0
  transport input none
line aux 0
line vty 0 4
  password lab
  login
!
end

```

7500 NetFlow Output:

lnsl#sh ip cache verbose flow

IP packet size distribution (55453 total packets):

```

  1-32  64   96  128  160  192  224  256  288  320  352  384  416  448  480
  .000 .219 .007 .767 .005 .000 .000 .000 .000 .000 .000 .000 .000 .000 .000

  512  544  576 1024 1536 2048 2560 3072 3584 4096 4608
  .000 .000 .000 .000 .000 .000 .000 .000 .000 .000 .000

```

IP Flow Switching Cache, 4456704 bytes
 5 active, 65531 inactive, 52 added
 7287 aged polls, 0 flow alloc failures
 Active flows timeout in 30 minutes
 Inactive flows timeout in 15 seconds
 last clearing of statistics never

Protocol	Total	Flows	Packets	Bytes	Packets	Active(Sec)	Idle(Sec)
-----	Flows	/Sec	/Flow	/Pkt	/Sec	/Flow	/Flow
TCP-Telnet	18	0.0	650	40	1.0	222.3	9.3
UDP-other	12	0.0	5	80	0.0	2.4	15.6
ICMP	17	0.0	2465	99	3.7	147.5	15.4
Total:	47	0.0	1142	87	4.8	139.1	13.2

SrcIf	SrcIPAddress	DstIf	DstIPAddress	Pr	TOS	Flgs	Pkts
Port	Msk	AS	NextHop			B/Pk	Active
Fa0/1/0	10.3.1.1	Local	10.3.1.2	11	00	10	722

SrcIf	SrcIPAddress	DstIf	DstIPAddress	Pr	TOS	Flgs	Pkts
Port	Msk	AS	NextHop			B/Pk	Active
06A5 /0 0		06A5 /0 0	0.0.0.0			111	29.2
Vi2	10.8.1.1	Fa4/1/0	15.2.254.254	06	C0	18	395
0017 /0 0		2AFB /0 0	0.0.0.0			41	30.0
Fa4/1/0	15.2.254.254	Vi2	10.8.1.1	06	C0	18	119
2AFB /0 0		0017 /0 0	0.0.0.0			40	30.0
Vi1	10.2.1.2	Fa4/1/0	15.1.254.254	01	00	10	366
0000 /0 0		0800 /0 0	0.0.0.0			100	14.6
Fa4/1/0	15.1.254.254	Vi1	10.2.1.2	01	00	10	366
0000 /0 0		0000 /0 0	0.0.0.0			100	14.6

lnsl#sh ip cache flow

IP packet size distribution (56201 total packets):

1-32	64	96	128	160	192	224	256	288	320	352	384	416	448	480
.000	.219	.009	.762	.008	.000	.000	.000	.000	.000	.000	.000	.000	.000	.000
512	544	576	1024	1536	2048	2560	3072	3584	4096	4608				
.000	.000	.000	.000	.000	.000	.000	.000	.000	.000	.000				

IP Flow Switching Cache, 4456704 bytes

5 active, 65531 inactive, 52 added

7317 ager polls, 0 flow alloc failures

Active flows timeout in 30 minutes

Inactive flows timeout in 15 seconds

last clearing of statistics never

Protocol	Total	Flows	Packets	Bytes	Packets	Active(Sec)	Idle(Sec)
-----	Flows	/Sec	/Flow	/Pkt	/Sec	/Flow	/Flow
TCP-Telnet	18	0.0	650	40	1.0	222.3	9.3
UDP-other	12	0.0	5	80	0.0	2.4	15.6
ICMP	17	0.0	2465	99	3.7	147.5	15.4
Total:	47	0.0	1142	87	4.8	139.1	13.2

SrcIf	SrcIPAddress	DstIf	DstIPAddress	Pr	SrcP	DstP	Pkts
Fa0/1/0	10.3.1.1	Local	10.3.1.2	11	06A5	06A5	1010
Vi2	10.8.1.1	Fa4/1/0	15.2.254.254	06	0017	2AFB	520

SrcIf	SrcIPAddress	DstIf	DstIPAddress	Pr	SrcP	DstP	Pkts
Fa4/1/0	15.2.254.254	Vi2	10.8.1.1	06	2AFB	0017	144
Vi1	10.2.1.2	Fa4/1/0	15.1.254.254	01	0000	0800	504
Fa4/1/0	15.1.254.254	Vi1	10.2.1.2	01	0000	0000	504

Appendix H: MPLS-VPN Configurations and Console Output

2500 Configuration:

2500-NetFlow#sh run

Building configuration...

Current configuration : 596 bytes

```

!
version 12.1
no service single-slot-reload-enable
no service pad
service timestamps debug uptime
service timestamps log uptime
no service password-encryption
!
hostname 2500-NetFlow
!
logging rate-limit console 10 except errors
enable secret 5 $1$5790$qdhDIaRrMXMHdrmA4eFc./
!
ip subnet-zero
no ip finger
no ip domain-lookup
!
interface Ethernet0
 ip address 10.1.10.1 255.255.255.0
!
interface Serial0
 no ip address
 shutdown
!
router rip
 version 2
 network 10.0.0.0
!
no ip http server
ip classless

```

```
!  
line con 0  
  transport input none  
line 1 16  
line aux 0  
line vty 0 4  
  login  
!  
end
```

7140 Configuration:

```
7100-NetFlow#sh run  
Building configuration...
```

```
Current configuration : 1936 bytes
```

```
!  
version 12.1  
no service single-slot-reload-enable  
service timestamps debug uptime  
service timestamps log uptime  
no service password-encryption  
!  
hostname 7100-NetFlow  
!  
boot system flash slot0:/c7100-js-mz.121-5.T.bin  
logging rate-limit console 10 except errors  
enable secret 5 $1$sL55$VzvKQXi/0SXj/V.WkqM7J1  
!  
ip subnet-zero  
!  
no ip finger  
no ip domain-lookup  
!  
ip vrf green  
  rd 300:1  
  route-target export 300:1  
  route-target import 300:1  
ip cef  
call rsvp-sync  
cns event-service server  
!
```

```
interface Loopback0
 ip address 172.16.30.1 255.255.255.255
```

```
!
```

```
interface FastEthernet0/0
 ip vrf forwarding green
 ip address 10.1.10.2 255.255.255.0
 ip route-cache flow
 duplex auto
 speed 10
 mpls netflow egress
```

```
!
```

```
interface FastEthernet0/1
 ip address 172.16.10.1 255.255.255.0
 duplex auto
 speed auto
 tag-switching ip
```

```
!
```

```
interface Serial1/0
 no ip address
 shutdown
 framing c-bit
 cablelength 10
 dsu bandwidth 44210
```

```
!
```

```
interface Serial1/1
 no ip address
 ip route-cache flow
 no keepalive
 shutdown
 framing c-bit
 cablelength 10
 dsu bandwidth 44210
```

```
!
```

```
interface ATM4/0
 no ip address
 shutdown
 no atm ilmi-keepalive
```

```
!
```

```
router ospf 1
 router-id 172.16.30.1
 log-adjacency-changes
```

```
network 172.16.0.0 0.0.255.255 area 0
!
router rip
version 2
!
address-family ipv4 vrf green
version 2
redistribute connected
redistribute bgp 6 metric 2
network 10.0.0.0
no auto-summary
exit-address-family
!
router bgp 6
bgp log-neighbor-changes
neighbor 172.16.20.2 remote-as 6
neighbor 172.16.20.2 update-source Loopback0
!
address-family ipv4 vrf green
redistribute rip metric 2
no auto-summary
no synchronization
exit-address-family
!
address-family vpnv4
neighbor 172.16.20.2 activate
neighbor 172.16.20.2 send-community both
exit-address-family
!
ip kerberos source-interface any
ip classless
no ip http server
!
line con 0
transport input none
line aux 0
line vty 0 4
login
line vty 5 15
```

```
login
```

```
!
```

```
end
```

7206 Configuration:

```
7200-netflow#sh run
```

```
Building configuration...
```

```
Current configuration : 2074 bytes
```

```
!
```

```
version 12.1
```

```
no service single-slot-reload-enable
```

```
service timestamps debug uptime
```

```
service timestamps log uptime
```

```
no service password-encryption
```

```
!
```

```
hostname 7200-netflow
```

```
!
```

```
boot system flash slot0:c7200-js-mz.121-5.T1.bin
```

```
logging rate-limit console 10 except errors
```

```
enable secret 5 $1$LsiL$09X3YbqL7sd9o/fndrGI01
```

```
!
```

```
ip subnet-zero
```

```
!
```

```
no ip finger
```

```
no ip domain-lookup
```

```
ip host PAGENT-SECURITY-V3 92.16.52.64 54.73.0.0
```

```
!
```

```
ip vrf green
```

```
rd 300:1
```

```
route-target export 300:1
```

```
route-target import 300:1
```

```
ip cef
```

```
call rsvp-sync
```

```
cns event-service server
```

```
!
```

```
interface Loopback0
```

```
ip address 172.16.20.2 255.255.255.255
```

```
!
```

```
interface FastEthernet0/0
```

```
ip address 172.16.10.2 255.255.255.0
```

```
duplex half
tag-switching ip
!
interface ATM1/0
no ip address
shutdown
no atm ilmi-keepalive
!
interface Serial2/0
no ip address
shutdown
framing c-bit
cablelength 10
dsu bandwidth 44210
!
interface Serial3/0
no ip address
ip route-cache flow
no keepalive
shutdown
framing c-bit
cablelength 10
dsu bandwidth 44210
!
interface FastEthernet4/0
ip vrf forwarding green
ip address 192.168.10.2 255.255.255.0
ip route-cache flow
duplex half
mpls netflow egress
!
router ospf 1
router-id 172.16.20.2
log-adjacency-changes
network 172.16.0.0 0.0.255.255 area 0
!
router rip
version 2
!
address-family ipv4 vrf green
version 2
```



```
redistribute connected
redistribute bgp 6 metric 2
network 192.168.10.0
no auto-summary
exit-address-family
!
router bgp 6
  bgp log-neighbor-changes
  neighbor 172.16.30.1 remote-as 6
  !
  address-family ipv4 vrf green
    redistribute rip metric 2
    no auto-summary
    no synchronization
    exit-address-family
  !
  address-family vpnv4
    neighbor 172.16.30.1 activate
    neighbor 172.16.30.1 send-community both
    exit-address-family
  !
ip kerberos source-interface any
ip classless
ip route 172.21.200.0 255.255.255.0 10.0.154.1
ip flow-export version 5 peer-as
no ip http server
!
gatekeeper
  shutdown
!
line con 0
  exec-timeout 0 0
  transport input none
line aux 0
line vty 0 4
  login
line vty 5 15
  login
!
no scheduler max-task-time
end
```

3640 Configuration:

3640-NetFlow#sh run

Building configuration...

Current configuration : 1064 bytes

!

version 12.1

no service single-slot-reload-enable

service timestamps debug uptime

service timestamps log uptime

no service password-encryption

!

hostname 3640-NetFlow

!

boot system flash slot0:c3640-i-mz.121-5.T.bin

logging rate-limit console 10 except errors

enable secret 5 \$1\$SNMK\$SPKZRgaYV4UAjPZ/Ggt1h0

!

ip subnet-zero

ip cef

!

no ip finger

no ip domain-lookup

!

interface Ethernet0/0

no ip address

shutdown

half-duplex

!

interface Serial0/0

no ip address

encapsulation lapb multi

shutdown

!

interface Ethernet0/1

no ip address

shutdown

half-duplex

!

interface FastEthernet2/0

ip address 192.168.10.1 255.255.255.0

```
duplex auto
speed auto
!
interface Serial3/0
  no ip address
  shutdown
  clockrate 64000
!
interface Serial3/1
  no ip address
  shutdown
!
interface Serial3/2
  no ip address
  shutdown
!
interface Serial3/3
  no ip address
  shutdown
!
router rip
  version 2
  redistribute connected
  network 192.168.10.0
!
ip classless
no ip http server
!
line con 0
  transport input none
line aux 0
line vty 0 4
  password lab
  login
!
end
```

7140 NetFlow Output:

7100-NetFlow#sh ip cache verbose flow

IP packet size distribution (270663 total packets):

1-32	64	96	128	160	192	224	256	288	320	352	384	416	448	480
.000	.001	.000	.998	.000	.000	.000	.000	.000	.000	.000	.000	.000	.000	.000
512	544	576	1024	1536	2048	2560	3072	3584	4096	4608				
.000	.000	.000	.000	.000	.000	.000	.000	.000	.000	.000				

IP Flow Switching Cache, 4456704 bytes

4 active, 65532 inactive, 141 added
 3870 aged polls, 0 flow alloc failures
 Active flows timeout in 30 minutes
 Inactive flows timeout in 15 seconds
 last clearing of statistics never

Protocol	Total	Flows	Packets	Bytes	Packets	Active(Sec)	Idle(Sec)
-----	Flows	/Sec	/Flow	/Pkt	/Sec	/Flow	/Flow
TCP-Telnet	12	0.0	18	73	0.0	7.4	10.6
TCP-BGP	32	0.0	1	52	0.0	0.1	15.3
TCP-other	47	0.0	1	49	0.0	4.9	15.4
UDP-other	2	0.0	2	493	0.0	22.5	15.3
ICMP	44	0.0	6091	100	95.7	30.7	15.5
Total:	137	0.0	1959	99	95.8	12.6	15.0

SrcIf	SrcIPAddress	DstIf	DstIPAddress	Pr	TOS	Flgs	Pkts
Port Msk AS		Port Msk AS	NextHop			B/Pk	Active
Fa0/0	10.1.10.1	Fa0/1	192.168.10.1	01	00	10	1390
0000 /0 0		0800 /0 0	0.0.0.0			100	7.1
Fa0/1	192.168.10.1	Fa0/0	10.1.10.1	01	00	10	1390
0000 /24 0		0000 /24 0	10.1.10.1			100	7.1
Fa0/0	10.1.10.1	Fa0/1	192.168.10.1	06	C0	18	5
0017 /0 0		2AFA /0 0	0.0.0.0			275	1.3
Fa0/1	192.168.10.1	Fa0/0	10.1.10.1	06	C0	18	6
2AFA /24 0		0017 /24 0	10.1.10.1			40	1.5

7100-NetFlow#sh ip cache flow

IP packet size distribution (273361 total packets):

1-32	64	96	128	160	192	224	256	288	320	352	384	416	448	480
.000	.001	.000	.998	.000	.000	.000	.000	.000	.000	.000	.000	.000	.000	.000
512	544	576	1024	1536	2048	2560	3072	3584	4096	4608				
.000	.000	.000	.000	.000	.000	.000	.000	.000	.000	.000				

IP Flow Switching Cache, 4456704 bytes
 4 active, 65532 inactive, 141 added
 3898 aged polls, 0 flow alloc failures
 Active flows timeout in 30 minutes
 Inactive flows timeout in 15 seconds
 last clearing of statistics never

Protocol	Total	Flows	Packets	Bytes	Packets	Active(Sec)	Idle(Sec)
-----	Flows	/Sec	/Flow	/Pkt	/Sec	/Flow	/Flow
TCP-Telnet	12	0.0	18	73	0.0	7.4	10.6
TCP-BGP	32	0.0	1	52	0.0	0.1	15.3
TCP-other	47	0.0	1	49	0.0	4.9	15.4
UDP-other	2	0.0	2	493	0.0	22.5	15.3
ICMP	44	0.0	6091	100	95.3	30.7	15.5
Total:	137	0.0	1959	99	95.5	12.6	15.0

SrcIf	SrcIPAddress	DstIf	DstIPAddress	Pr	SrcP	DstP	Pkts
SrcIf	SrcIPAddress	DstIf	DstIPAddress	Pr	SrcP	DstP	Pkts
Fa0/0	10.1.10.1	Fa0/1	192.168.10.1	01	0000	0800	2681
Fa0/1	192.168.10.1	Fa0/0	10.1.10.1	01	0000	0000	2786
Fa0/0	10.1.10.1	Fa0/1	192.168.10.1	06	0017	2AFA	8
Fa0/1	192.168.10.1	Fa0/0	10.1.10.1	06	2AFA	0017	10

Appendix I: Tunnel Hopping Configurations and Console Output

2500 Configuration:

```
2500-NetFlow#sh run
Building configuration...
```

```
Current configuration : 813 bytes
!
version 12.1
no service single-slot-reload-enable
no service pad
service timestamps debug uptime
service timestamps log uptime
no service password-encryption
!
hostname 2500-NetFlow
!
logging rate-limit console 10 except errors
```

```
enable secret 5 $1$5790$qdhDIaRrMXMHdrmA4eFc./
```

```
!
```

```
ip subnet-zero
```

```
no ip finger
```

```
no ip domain-lookup
```

```
!
```

```
interface Loopback0
```

```
ip address 10.1.30.1 255.255.255.0
```

```
!
```

```
interface Tunnel0
```

```
ip address 10.1.20.1 255.255.255.0
```

```
tunnel source 10.1.10.1
```

```
tunnel destination 10.1.10.2
```

```
!
```

```
interface Ethernet0
```

```
ip address 10.1.10.1 255.255.255.0
```

```
!
```

```
interface Serial0
```

```
no ip address
```

```
shutdown
```

```
!
```

```
no ip http server
```

```
ip classless
```

```
ip route 0.0.0.0 0.0.0.0 10.1.10.2
```

```
ip route 192.168.0.0 255.255.0.0 Tunnel0
```

```
!
```

```
line con 0
```

```
transport input none
```

```
line 1 16
```

```
line aux 0
```

```
line vty 0 4
```

```
password lab
```

```
login
```

```
!
```

```
end
```

7140 Configuration:

```
7100-NetFlow#sh run
```

```
Building configuration...
```

```
Current configuration : 1663 bytes
```

```
!
version 12.1
no service single-slot-reload-enable
service timestamps debug uptime
service timestamps log uptime
no service password-encryption
!
hostname 7100-NetFlow
!
boot system flash slot0:/c7100-js-mz.121-5.T.bin
logging rate-limit console 10 except errors
enable secret 5 $1$sL55$VzvKQXi/0SXj/V.WkqM7J1
!
ip subnet-zero
!
no ip finger
no ip domain-lookup
!
ip cef
call rsvp-sync
cns event-service server
!
interface Tunnel0
 ip address 172.16.12.1 255.255.255.0
 ip route-cache flow
 tunnel source 172.16.11.1
 tunnel destination 172.16.11.2
!
interface Tunnell
 ip address 10.1.20.2 255.255.255.0
 ip route-cache flow
 tunnel source 10.1.10.2
 tunnel destination 10.1.10.1
!
interface FastEthernet0/0
 ip address 10.1.10.2 255.255.255.0
 ip route-cache flow
 duplex auto
 speed 10
!
interface FastEthernet0/1
```

```

no ip address
shutdown
duplex auto
speed auto
!
interface Serial1/0
ip address 172.16.11.1 255.255.255.0
encapsulation ppp
ip route-cache flow
framing c-bit
cablelength 10
dsu bandwidth 44210
clock source internal
!
interface Serial1/1
no ip address
encapsulation ppp
ip route-cache flow
shutdown
framing c-bit
cablelength 10
dsu bandwidth 44210
!
interface ATM4/0
no ip address
shutdown
atm clock INTERNAL
no atm ilmi-keepalive
!
ip kerberos source-interface any
ip classless
ip route 10.1.30.0 255.255.255.0 Tunnel1
ip route 192.168.10.0 255.255.255.0 Tunnel0
ip route 192.168.20.0 255.255.255.0 Tunnel0
ip route 192.168.30.0 255.255.255.0 Tunnel0
ip flow-export version 5
no ip http server
!
line con 0
transport input none
line aux 0

```



```
line vty 0 4
 password lab
 login
line vty 5 15
 login
!
end
```

7206 Configuration:

```
7200-netflow#sh run
Building configuration...
```

```
Current configuration : 1501 bytes
```

```
!
version 12.1
service timestamps debug uptime
service timestamps log uptime
no service password-encryption
!
hostname 7200-netflow
!
boot system flash slot0:c7200-is-mz.121-5a.bin
enable secret 5 $1$LsiL$09X3YbqL7sd9o/fndrGI01
!
ip subnet-zero
ip cef
no ip finger
no ip domain-lookup
ip host PAGENT-SECURITY-V3 92.16.52.64 54.73.0.0
!
interface Tunnel0
 ip address 172.16.12.2 255.255.255.0
 ip route-cache flow
 tunnel source 172.16.11.2
 tunnel destination 172.16.11.1
!
interface Tunnell
 ip address 192.168.20.2 255.255.255.0
 ip route-cache flow
 tunnel source 192.168.10.2
 tunnel destination 192.168.10.1
```

```
!  
interface FastEthernet0/0  
  no ip address  
  shutdown  
  half-duplex  
!  
interface ATM1/0  
  no ip address  
  shutdown  
  no atm ilmi-keepalive  
!  
interface Serial2/0  
  ip address 172.16.11.2 255.255.255.0  
  encapsulation ppp  
  ip route-cache flow  
  framing c-bit  
  cablelength 10  
  dsu bandwidth 44210  
!  
interface Serial3/0  
  no ip address  
  encapsulation ppp  
  ip route-cache flow  
  shutdown  
  framing c-bit  
  cablelength 10  
  dsu bandwidth 44210  
!  
interface FastEthernet4/0  
  ip address 192.168.10.2 255.255.255.0  
  ip route-cache flow  
  half-duplex  
!  
ip classless  
ip route 10.1.10.0 255.255.255.0 Tunnel0  
ip route 10.1.20.0 255.255.255.0 Tunnel0  
ip route 10.1.30.0 255.255.255.0 Tunnel0  
ip route 192.168.30.0 255.255.255.0 Tunnel1  
ip flow-export version 5  
no ip http server  
!
```

```
line con 0
  exec-timeout 0 0
  transport input none
line aux 0
line vty 0 4
  login
!
no scheduler max-task-time
end
```

3640 Configuration:

```
3640-NetFlow#sh run
Building configuration...
```

```
Current configuration : 1265 bytes
```

```
!
version 12.1
no service single-slot-reload-enable
service timestamps debug uptime
service timestamps log uptime
no service password-encryption
!
hostname 3640-NetFlow
!
boot system flash slot0:c3640-i-mz.121-5.T.bin
logging rate-limit console 10 except errors
enable secret 5 $1$SNMK$SPKZRgaYV4UAjPZ/Ggt1h0
!
ip subnet-zero
ip cef
!
no ip finger
no ip domain-lookup
!
interface Loopback0
  ip address 192.168.30.1 255.255.255.0
!
interface Tunnel0
  ip address 192.168.20.1 255.255.255.0
  ip route-cache flow
  tunnel source 192.168.10.1
```

```
tunnel destination 192.168.10.2
!
interface Ethernet0/0
no ip address
shutdown
half-duplex
!
interface Serial0/0
no ip address
encapsulation lapb multi
shutdown
no fair-queue
!
interface Ethernet0/1
no ip address
shutdown
half-duplex
!
interface FastEthernet2/0
ip address 192.168.10.1 255.255.255.0
ip route-cache flow
duplex auto
speed auto
!
interface Serial3/0
no ip address
shutdown
clockrate 64000
!
interface Serial3/1
no ip address
shutdown
!
interface Serial3/2
no ip address
shutdown
!
interface Serial3/3
no ip address
shutdown
!
```

```

ip classless
ip route 0.0.0.0 0.0.0.0 Tunnel0
no ip http server
!
line con 0
  transport input none
line aux 0
line vty 0 4
  password lab
  login
!
end

```

7140 NetFlow Output:

7100-NetFlow#sh ip cache verbose flow

IP packet size distribution (246737 total packets):

```

 1-32  64  96 128 160 192 224 256 288 320 352 384 416 448 480
 .000 .002 .000 .996 .000 .000 .000 .000 .000 .000 .000 .000 .000 .000 .000

 512  544  576 1024 1536 2048 2560 3072 3584 4096 4608
 .000 .000 .000 .000 .000 .000 .000 .000 .000 .000 .000

```

```

IP Flow Switching Cache, 4456704 bytes
 8 active, 65528 inactive, 204 added
5567 ager polls, 0 flow alloc failures
Active flows timeout in 30 minutes
Inactive flows timeout in 15 seconds
last clearing of statistics never

```

Protocol	Total	Flows	Packets	Bytes	Packets	Active(Sec)	Idle(Sec)
-----	Flows	/Sec	/Flow	/Pkt	/Sec	/Flow	/Flow
TCP-Telnet	18	0.0	22	89	0.0	9.3	12.3
UDP-other	59	0.0	1	91	0.0	1.2	15.5
ICMP	42	0.0	3002	99	23.4	21.2	15.4
GRE	77	0.0	1643	106	23.5	15.0	15.5
Total:	196	0.0	1291	103	47.1	11.7	15.2

SrcIf	SrcIPAddress	DstIf	DstIPAddress	Pr	TOS	Flgs	Pkts
Port Msk AS		Port Msk AS	NextHop			B/Pk	Active
Fa0/0	10.1.10.1	Local	10.1.10.2	2F	00	10	3056
0000 /0 0		0000 /0 0	0.0.0.0			124	20.9
Se1/0	172.16.11.2	Local	172.16.11.1	2F	00	10	3055

```

0000 /0 0          0000 /0 0      0.0.0.0          124    20.9
Fa0/0          10.1.10.1      Local          10.1.10.2      2F C0 10    15
0000 /0 0          0000 /0 0      0.0.0.0          281    27.0
Se1/0          172.16.11.2    Local          172.16.11.1    2F C0 10    21
0000 /0 0          0000 /0 0      0.0.0.0          64     27.2
Tu0            192.168.30.1   Tu1            10.1.20.1      01 00 10    3058
0000 /0 0          0000 /0 0      0.0.0.0          100    21.0
Tu1            10.1.20.1      Tu0            192.168.30.1   01 00 10    3215
0000 /0 0          0800 /0 0      0.0.0.0          100    22.0
Tu0            192.168.20.1   Tu1            10.1.30.1      06 C0 18    21
2AFA /0 0          0017 /0 0      0.0.0.0          40     27.2
Tu1            10.1.30.1      Tu0            192.168.20.1   06 C0 18    15
0017 /0 0          2AFA /0 0      0.0.0.0          257    27.0

```

7100-NetFlow#sh ip cache flow

IP packet size distribution (251645 total packets):

```

 1-32  64  96 128 160 192 224 256 288 320 352 384 416 448 480
 .000 .002 .000 .996 .000 .000 .000 .000 .000 .000 .000 .000 .000 .000 .000

 512  544  576 1024 1536 2048 2560 3072 3584 4096 4608
 .000 .000 .000 .000 .000 .000 .000 .000 .000 .000 .000

```

IP Flow Switching Cache, 4456704 bytes
 8 active, 65528 inactive, 204 added
 5631 ager polls, 0 flow alloc failures
 Active flows timeout in 30 minutes
 Inactive flows timeout in 15 seconds
 last clearing of statistics never

Protocol	Total	Flows	Packets	Bytes	Packets	Active(Sec)	Idle(Sec)
-----	Flows	/Sec	/Flow	/Pkt	/Sec	/Flow	/Flow
TCP-Telnet	18	0.0	22	89	0.0	9.3	12.3
UDP-other	59	0.0	1	91	0.0	1.2	15.5
ICMP	42	0.0	3002	99	23.4	21.2	15.4
GRE	77	0.0	1643	106	23.5	15.0	15.5
Total:	196	0.0	1291	103	47.0	11.7	15.2

SrcIf	SrcIPAddress	DstIf	DstIPAddress	Pr	SrcP	DstP	Pkts
Fa0/0	10.1.10.1	Local	10.1.10.2	2F	0000	0000	4300
Se1/0	172.16.11.2	Local	172.16.11.1	2F	0000	0000	4300
Fa0/0	10.1.10.1	Local	10.1.10.2	2F	0000	0000	19
Se1/0	172.16.11.2	Local	172.16.11.1	2F	0000	0000	27
Tu0	192.168.30.1	Tu1	10.1.20.1	01	0000	0000	4302

Tu1	10.1.20.1	Tu0	192.168.30.1	01 0000 0800	4303
Tu0	192.168.20.1	Tu1	10.1.30.1	06 2AFA 0017	27
Tu1	10.1.30.1	Tu0	192.168.20.1	06 0017 2AFA	19



Corporate Headquarters

Cisco Systems, Inc.
 170 West Tasman Drive
 San Jose, CA 95134-1706
 USA
 www.cisco.com
 Tel: 408 526-4000
 800 553-NETS (6387)
 Fax: 408 526-4100

European Headquarters

Cisco Systems International BV
 Haarlerbergpark
 Haarlerbergweg 13-19
 1101 CH Amsterdam
 The Netherlands
 www-europe.cisco.com
 Tel: 31 0 20 357 1000
 Fax: 31 0 20 357 1100

Americas Headquarters

Cisco Systems, Inc.
 170 West Tasman Drive
 San Jose, CA 95134-1706
 USA
 www.cisco.com
 Tel: 408 526-7660
 Fax: 408 527-0883

Asia Pacific Headquarters

Cisco Systems, Inc.
 168 Robinson Road
 #28-01 Capital Tower
 Singapore 068912
 www.cisco.com
 Tel: +65 6317 7777
 Fax: +65 6317 7799

Cisco Systems has more than 200 offices in the following countries and regions. Addresses, phone numbers, and fax numbers are listed on **the Cisco Website at www.cisco.com/go/offices.**

Argentina • Australia • Austria • Belgium • Brazil • Bulgaria • Canada • Chile • China PRC • Colombia • Costa Rica • Croatia • Cyprus
 Czech Republic • Denmark • Dubai, UAE • Finland • France • Germany • Greece • Hong Kong SAR • Hungary • India • Indonesia • Ireland • Israel
 Italy • Japan • Korea • Luxembourg • Malaysia • Mexico • The Netherlands • New Zealand • Norway • Peru • Philippines • Poland • Portugal
 Puerto Rico • Romania • Russia • Saudi Arabia • Scotland • Singapore • Slovakia • Slovenia • South Africa • Spain • Sweden • Switzerland • Taiwan
 Thailand • Turkey • Ukraine • United Kingdom • United States • Venezuela • Vietnam • Zimbabwe

Copyright © 2006 Cisco Systems, Inc. All rights reserved. CCSP, CCVP, the Cisco Square Bridge logo, Follow Me Browsing, and StackWise are trademarks of Cisco Systems, Inc.; Changing the Way We Work, Live, Play, and Learn, and iQuick Study are service marks of Cisco Systems, Inc.; and Access Registrar, Aironet, BPX, Catalyst, CCDA, CCDP, CCIE, CCIP, CCNA, CCNP, Cisco, the Cisco Certified Internetwork Expert logo, Cisco IOS, Cisco Press, Cisco Systems, Cisco Systems Capital, the Cisco Systems logo, Cisco Unity, Enterprise/Solver, EtherChannel, EtherFast, EtherSwitch, Fast Step, FormShare, GigaDrive, GigaStack, HomeLink, Internet Quotient, IOS, IP/TV, iQ Expertise, the iQ logo, iQ Net Readiness Scorecard, LightStream, Linksys, MeetingPlace, MGX, the Networkers logo, Networking Academy, Network Registrar, Packet, PIX, Post-Routing, Pre-Routing, ProConnect, RateMUX, ScriptShare, SlideCast, SMARTnet, The Fastest Way to Increase Your Internet Quotient, and TransPath are registered trademarks of Cisco Systems, Inc. and/or its affiliates in the United States and certain other countries.

All other trademarks mentioned in this document or Website are the property of their respective owners. The use of the word partner does not imply a partnership relationship between Cisco and any other company. (0601R)