

# CSNA Configuration Relationships

This scenario illustrates the Cisco SNA (CSNA) configuration of the router and relates the router configuration to the XCA Major Node and Switched Major Node definitions of Virtual Telecommunications Access Method (VTAM), the OS/390 Input/Output Configuration Program (IOCP) generation commands, and the PC setup. Figure 1 shows the major configuration parameters of the Channel Interface Processor (CIP) and the Token Ring interfaces and how they are logically combined using the source-bridge command. Figure 2 details the relationships between configuration parameters. In this scenario, the CIP connects to the host via an ESCON Director and the PC establishes a Logical Link Control type 2 (LLC2) session with the host via Token Ring using CSNA in the router. This document assumes knowledge of the command structure but not the parameter relationships.

Figure 1 CSNA Network Scenario

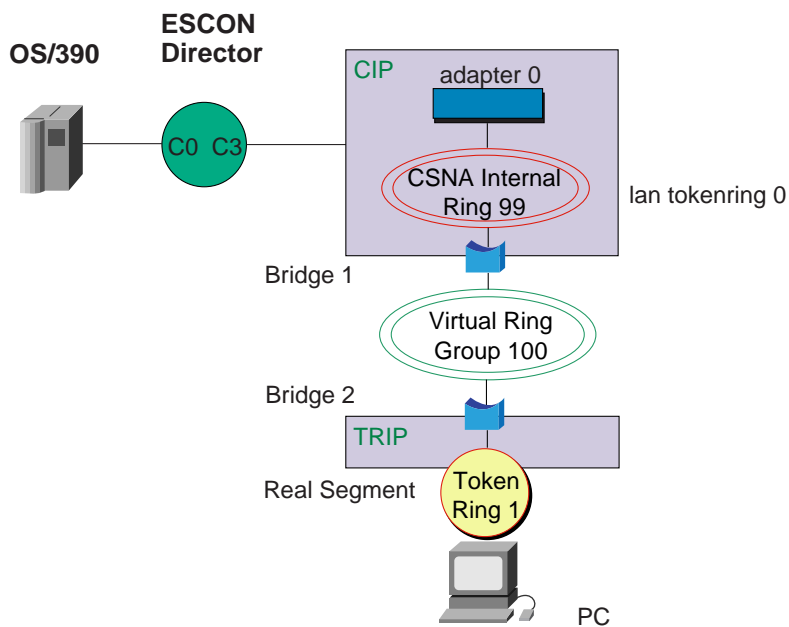
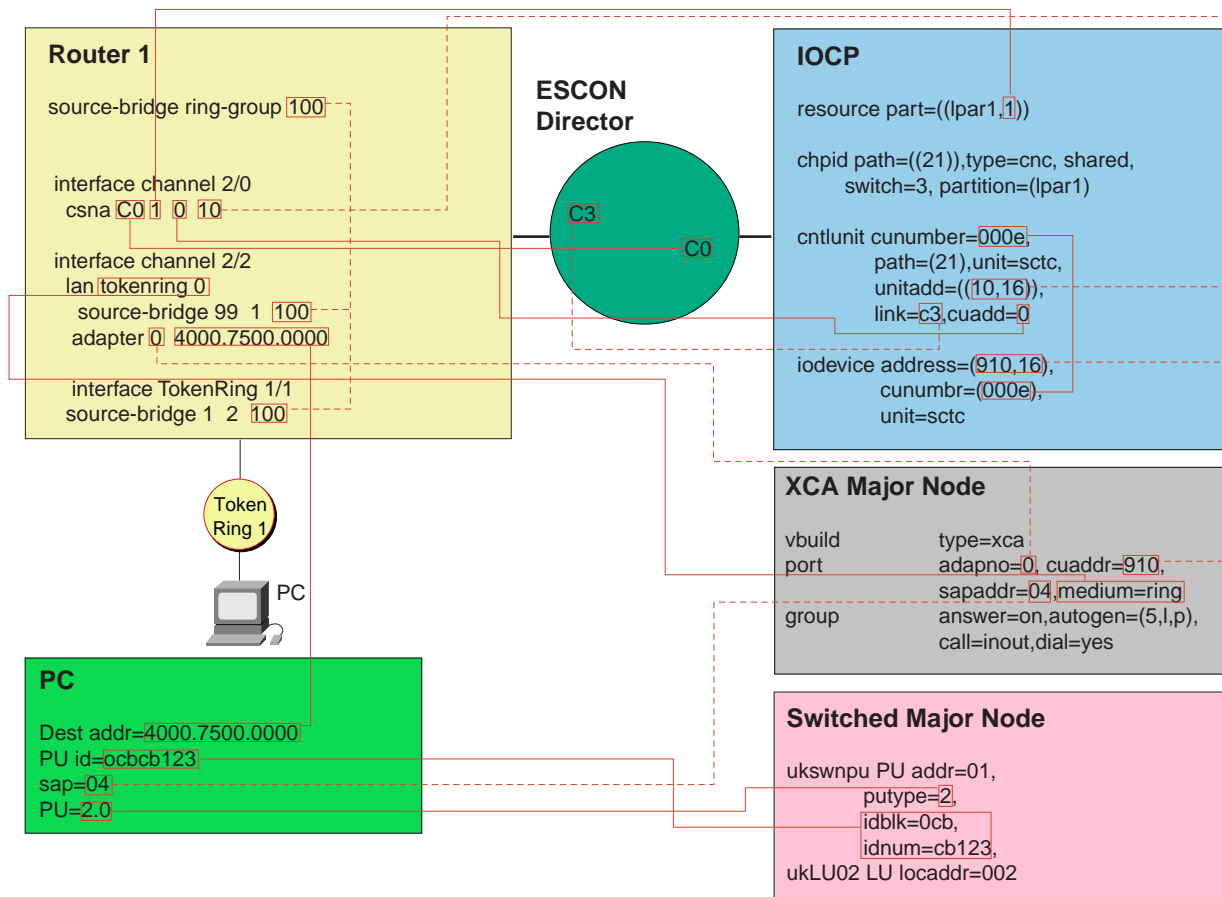

Figure 2 CSNA Parameter Relationships



Corporate Headquarters  
Cisco Systems, Inc.  
170 West Tasman Drive  
San Jose, CA 95134-1706  
USA  
<http://www.cisco.com>  
Tel: 408 526-4000  
800 553-NETS (6387)  
Fax: 408 526-4100

European Headquarters  
Cisco Systems Europe  
11, Rue Camille Desmoulins  
92782 Issy Les Moulineaux  
Cedex 9  
France  
<http://www-europe.cisco.com>  
Tel: 33 1 58 04 60 00  
Fax: 33 1 58 04 61 00

Americas  
Headquarters  
Cisco Systems, Inc.  
170 West Tasman Drive  
San Jose, CA 95134-1706  
USA  
<http://www.cisco.com>  
Tel: 408 526-7660  
Fax: 408 527-0883

Asia Headquarters  
Nihon Cisco Systems K.K.  
Fuji Building, 9th Floor  
3-2-3 Marunouchi  
Chiyoda-ku, Tokyo 100  
Japan  
<http://www.cisco.com>  
Tel: 81 3 5219 6250  
Fax: 81 3 5219 6001

Cisco Systems has more than 200 offices in the following countries. Addresses, phone numbers, and fax numbers are listed on the Cisco Connection Online Web site at <http://www.cisco.com/go/offices>.

Argentina • Australia • Austria • Belgium • Brazil • Canada • Chile • China • Colombia • Costa Rica • Croatia • Czech Republic • Denmark • Dubai, UAE  
Finland • France • Germany • Greece • Hong Kong • Hungary • India • Indonesia • Ireland • Israel • Italy • Japan • Korea • Luxembourg • Malaysia  
Mexico • The Netherlands • New Zealand • Norway • Peru • Philippines • Poland • Portugal • Puerto Rico • Romania • Russia • Saudi Arabia • Singapore  
Slovakia • Slovenia • South Africa • Spain • Sweden • Switzerland • Taiwan • Thailand • Turkey • Ukraine • United Kingdom • United States • Venezuela

Copyright © 2000, Cisco Systems, Inc. All rights reserved. Printed in the USA. Cisco, Cisco Systems, and the Cisco Systems logo are registered trademarks of Cisco Systems, Inc. or its affiliates in the U.S. and certain other countries. All other trademarks mentioned in this document are the property of their respective owners. The use of the word partner does not imply a partnership relationship between Cisco and any of its resellers. (9912R) SPS 4/00