

Why should I Care about Cisco Mobile Ad Hoc Networking (MANET) Enhancements for Router-Radio Links?

Cisco MANET enhancements address the challenges faced when merging IP routing and mobile radio communications in ad hoc networking applications. With this release, Cisco provides capabilities that enable:

- Optimal route selection based on Layer 2 feedback from the radio network
- Faster convergence when nodes join and leave the network
- Efficient integration of point-to-point, directional radio topologies with multi hop routing
- Flow-controlled communications between the radio and its partner router

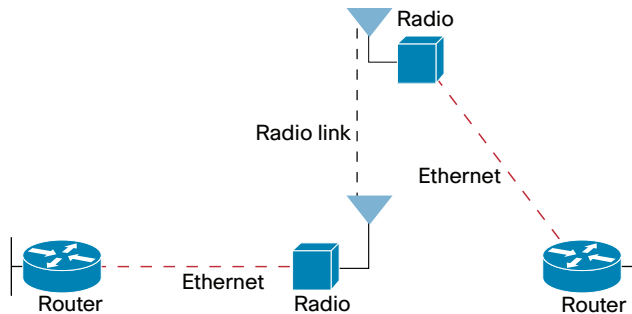

What Problems Need to be Solved?

- Fluctuations in radio link quality impact throughput and need to be factored into routing "best path" selection
- The self-forming, self-healing nature of a MANET requires immediate recognition of topology changes to ensure fast convergence
- Directional radios form point-to-point networks with neighbors, which increases the size of the router's database and reduces routing efficiency
- Radios need to control the rate at which routers send information, to minimize the need for queuing within the radio

Manet Enhancements for Router-Radio Links

The solution employs PPP-over-Ethernet (PPPoE) sessions to enable intra-nodal communications between a router and its partner radio. A PPPoE session is established between router and radio on behalf of every other router/radio neighbor located in the MANET. Once the PPPoE sessions are established, a PPP session is established end to end.

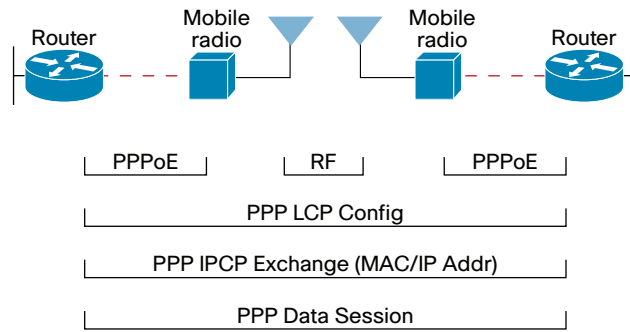

- Neighbor Up/Down Signaling: enables Cisco routers to provide faster network convergence by reacting to link status signals generated by the radio, rather than waiting for protocol timers to expire. The routing protocols (OSPFv3 or EIGRP) respond immediately to these link status signals by expediting adjacency formation or tear-down.
- Link Quality Metrics Reporting: the PPPoE protocol has been extended to enable a radio to report link quality metric information to a router. Cisco routers have been enhanced so that OSPFv3 or EIGRP routing protocols can factor link quality metrics into route cost calculations.
- PPPoE Credit-Based Flow Control: this PPPoE extension allows a receiver to control the rate at which a sender can transmit data for each PPPoE session, so that the need for queuing in the radio is minimized.
- Virtual Multipoint Interface (VMI): aggregates per-neighbor PPPoE sessions and maps these to appear as a single point-to-multipoint, multi-access, broadcast-capable network.

What are the Benefits of Cisco MANET Enhancements?

- Enables network-based applications and information to be delivered reliably and quickly over directional radio links
- Provides faster convergence and optimal route selection so that delay-sensitive traffic, such as voice and video, are not disrupted
- Reduces impact on radio equipment by minimizing the need for internal queuing/buffering; also provides consistent Quality of Service for networks with multiple radios

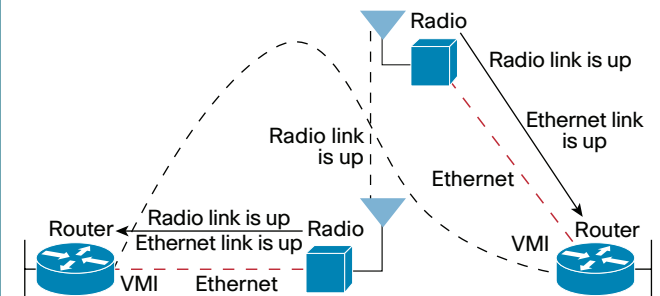

Why Cisco?

Cisco Transportable Service-Oriented Network Architecture (T-SONA) extends the benefits of intelligent information networks to highly mobile users. As the global leader in mission-critical networking and IP communications, Cisco is uniquely positioned to deliver reliable and efficient converged voice, video, and data solutions to organizations around the world. Cisco solutions are backed by award-winning technical support and advanced services.