



Cisco Cable Clock Card Hardware Installation Guide for the Cisco uBR7246VXR Universal Broadband Router

Product Numbers: UBR-CLK-T1(=)
Platforms Supported: Cisco uBR7246 VXR

Americas Headquarters
Cisco Systems, Inc.
170 West Tasman Drive
San Jose, CA 95134-1706
USA
<http://www.cisco.com>
Tel: 408 526-4000
800 553-NETS (6387)
Fax: 408 527-0883

Text Part Number: OL-26705-01

THE SPECIFICATIONS AND INFORMATION REGARDING THE PRODUCTS IN THIS MANUAL ARE SUBJECT TO CHANGE WITHOUT NOTICE. ALL STATEMENTS, INFORMATION, AND RECOMMENDATIONS IN THIS MANUAL ARE BELIEVED TO BE ACCURATE BUT ARE PRESENTED WITHOUT WARRANTY OF ANY KIND, EXPRESS OR IMPLIED. USERS MUST TAKE FULL RESPONSIBILITY FOR THEIR APPLICATION OF ANY PRODUCTS.

THE SOFTWARE LICENSE AND LIMITED WARRANTY FOR THE ACCOMPANYING PRODUCT ARE SET FORTH IN THE INFORMATION PACKET THAT SHIPPED WITH THE PRODUCT AND ARE INCORPORATED HEREIN BY THIS REFERENCE. IF YOU ARE UNABLE TO LOCATE THE SOFTWARE LICENSE OR LIMITED WARRANTY, CONTACT YOUR CISCO REPRESENTATIVE FOR A COPY.

The following information is for FCC compliance of Class A devices: This equipment has been tested and found to comply with the limits for a Class A digital device, pursuant to part 15 of the FCC rules. These limits are designed to provide reasonable protection against harmful interference when the equipment is operated in a commercial environment. This equipment generates, uses, and can radiate radio-frequency energy and, if not installed and used in accordance with the instruction manual, may cause harmful interference to radio communications. Operation of this equipment in a residential area is likely to cause harmful interference, in which case users will be required to correct the interference at their own expense.

The following information is for FCC compliance of Class B devices: The equipment described in this manual generates and may radiate radio-frequency energy. If it is not installed in accordance with Cisco's installation instructions, it may cause interference with radio and television reception. This equipment has been tested and found to comply with the limits for a Class B digital device in accordance with the specifications in part 15 of the FCC rules. These specifications are designed to provide reasonable protection against such interference in a residential installation. However, there is no guarantee that interference will not occur in a particular installation.

Modifying the equipment without Cisco's written authorization may result in the equipment no longer complying with FCC requirements for Class A or Class B digital devices. In that event, your right to use the equipment may be limited by FCC regulations, and you may be required to correct any interference to radio or television communications at your own expense.

You can determine whether your equipment is causing interference by turning it off. If the interference stops, it was probably caused by the Cisco equipment or one of its peripheral devices. If the equipment causes interference to radio or television reception, try to correct the interference by using one or more of the following measures:

- Turn the television or radio antenna until the interference stops.
- Move the equipment to one side or the other of the television or radio.
- Move the equipment farther away from the television or radio.
- Plug the equipment into an outlet that is on a different circuit from the television or radio. (That is, make certain the equipment and the television or radio are on circuits controlled by different circuit breakers or fuses.)

Modifications to this product not authorized by Cisco Systems, Inc. could void the FCC approval and negate your authority to operate the product.

The Cisco implementation of TCP header compression is an adaptation of a program developed by the University of California, Berkeley (UCB) as part of UCB's public domain version of the UNIX operating system. All rights reserved. Copyright © 1981, Regents of the University of California.

NOTWITHSTANDING ANY OTHER WARRANTY HEREIN, ALL DOCUMENT FILES AND SOFTWARE OF THESE SUPPLIERS ARE PROVIDED "AS IS" WITH ALL FAULTS. CISCO AND THE ABOVE-NAMED SUPPLIERS DISCLAIM ALL WARRANTIES, EXPRESSED OR IMPLIED, INCLUDING, WITHOUT LIMITATION, THOSE OF MERCHANTABILITY, FITNESS FOR A PARTICULAR PURPOSE AND NONINFRINGEMENT OR ARISING FROM A COURSE OF DEALING, USAGE, OR TRADE PRACTICE.

IN NO EVENT SHALL CISCO OR ITS SUPPLIERS BE LIABLE FOR ANY INDIRECT, SPECIAL, CONSEQUENTIAL, OR INCIDENTAL DAMAGES, INCLUDING, WITHOUT LIMITATION, LOST PROFITS OR LOSS OR DAMAGE TO DATA ARISING OUT OF THE USE OR INABILITY TO USE THIS MANUAL, EVEN IF CISCO OR ITS SUPPLIERS HAVE BEEN ADVISED OF THE POSSIBILITY OF SUCH DAMAGES.

Cisco and the Cisco logo are trademarks or registered trademarks of Cisco and/or its affiliates in the U.S. and other countries. To view a list of Cisco trademarks, go to this URL: www.cisco.com/go/trademarks. Third-party trademarks mentioned are the property of their respective owners. The use of the word partner does not imply a partnership relationship between Cisco and any other company. (1110R)

Cisco Cable Clock Card Hardware Installation Guide for the Cisco uBR7246VXR Universal Broadband Router

Copyright © 2009 Cisco Systems, Inc. All rights reserved.



CONTENTS

Preface v

- Objectives i-v
- Organization i-v
- Related Documentation i-vi
- Obtaining Documentation and Submitting a Service Request i-vi

CHAPTER 1

Overview 1-1

- Clock Card Overview 1-1
- Clock Source Overview 1-2
 - Modes of Operation 1-2
- Interface Specifications and Pinouts 1-3
- LEDs 1-4
- Clock Card Location in the Cisco uBR7246 VXR Chassis 1-5

CHAPTER 2

Preparing for Installation 2-1

- Required Tools and Equipment 2-1
- Software Requirements 2-1
- Safety Guidelines 2-2
 - Safety Warnings 2-2
 - Electrical Equipment Guidelines 2-3
 - Preventing Electrostatic Discharge Damage 2-4
- FCC Class A Compliance 2-4

CHAPTER 3

Removing and Installing the Clock Card 3-1

- Installation Overview 3-1
- Handling the Clock Card 3-2
- Online Insertion and Removal 3-2
- Warnings and Cautions 3-2
- Clock Card Removal and Installation 3-3
 - Cisco uBR7246 VXR—Removing a Clock Card 3-4
 - Cisco uBR7246 VXR—Installing a Clock Card 3-5
- Connecting a Clock Card Interface Cable 3-6

CHAPTER 4

Configuring the Clock Card 4-1

Minimum Software Requirements 4-1

Configuration and Diagnostic Cisco IOS Commands for the Clock Card 4-2

APPENDIX A

Clock Source Paths A-1



Preface

This preface describes the objectives and organization of this document and explains how to find additional information on related products and services. This preface contains the following sections:

- [Objectives, page v](#)
- [Organization, page v](#)
- [Related Documentation, page vi](#)
- [Obtaining Documentation and Submitting a Service Request, page vi](#)

Objectives

This document describes how to install and configure the Cisco Cable Clock Card field-replaceable unit used in the Cisco uBR7246 VXR universal broadband router.

Organization

This document contains the following chapters:

Section	Title	Description
Chapter 1	Overview	Describes the clock card and its supported features, LED displays and behavior, and interfaces.
Chapter 2	Preparing for Installation	Describes specific software and hardware requirements, safety considerations, tools required, and procedures you should perform <i>before the actual installation</i> .
Chapter 3	Removing and Installing the Clock Card	Describes the procedures for installing and removing the clock card in the Cisco uBR7246 VXR.
Chapter 4	Configuring the Clock Card	Provides instructions for configuring the clock card in the Cisco uBR7246 VXR.
Appendix A	Clock Source Paths	Provides schematic representations of the various circuit paths established by the clock card in a Cisco uBR7246 VXR, depending on your external connection(s) and configuration.

Related Documentation

Your router and the Cisco IOS software running on it contain extensive features and functionality, which are documented in the following resources:

- Cisco IOS software:

For configuration information and support, refer to the modular configuration and modular command reference publications in the Cisco IOS software configuration documentation set that corresponds to the software release installed on your Cisco hardware.



Note You can access Cisco IOS software configuration and hardware installation and maintenance documentation on the World Wide Web at <http://www.cisco.com>, <http://www-china.cisco.com>, or <http://www-europe.cisco.com>

- Cisco uBR7246 VXR universal broadband router:
 - For hardware installation, troubleshooting, and maintenance information, refer to the *Cisco uBR7200 Series Universal Broadband Router Hardware Installation Guide*.
 - For software configuration information, including detailed configuration information for the Cisco Cable Clock Card, refer to the *Cisco uBR7200 Series Universal Broadband Router Software Configuration Guide*.
 - For international agency compliance, safety, and statutory information for WAN interfaces, refer to the *Regulatory Compliance and Safety Information* appendix in the *Cisco uBR7200 Series Universal Broadband Router Hardware Installation Guide*.
- To view Cisco documentation or obtain general information about the documentation, refer to the “[Obtaining Documentation and Submitting a Service Request](#)” section, next.

Obtaining Documentation and Submitting a Service Request

For information on obtaining documentation, submitting a service request, and gathering additional information, see the monthly *What's New in Cisco Product Documentation*, which also lists all new and revised Cisco technical documentation, at:

<http://www.cisco.com/en/US/docs/general/whatsnew/whatsnew.html>

Subscribe to the *What's New in Cisco Product Documentation* as an RSS feed and set content to be delivered directly to your desktop using a reader application. The RSS feeds are a free service. Cisco currently supports RSS Version 2.0.



CHAPTER 1

Overview

This chapter describes the Cisco Cable Clock Card and contains the following sections:

- [Clock Card Overview, page 1-1](#)
- [Clock Source Overview, page 1-2](#)
- [Interface Specifications and Pinouts, page 1-3](#)
- [LEDs, page 1-4](#)
- [Clock Card Location in the Cisco uBR7246 VXR Chassis, page 1-5](#)

Clock Card Overview

The Cisco Cable Clock Card (see [Figure 1-1](#)) is a dual-port field-replaceable component that is designed to provide a reliable national clock signal to your Cisco uBR7246 VXR universal broadband router. The primary and secondary DB-15 interfaces on the front of the clock card connect to external T1 clock signal sources.

When installed in the Cisco uBR7246 VXR chassis, the clock card can propagate a national clock signal throughout the router's midplane by locking onto an external T1 signal originating over the PSTN, locking onto a T1 clock signal originating from a port adapter installed in the same chassis, or by connecting to a Global Positioning System (GPS) receiver generating a T1 clock signal.

Figure 1-1 Clock Card—Faceplate View

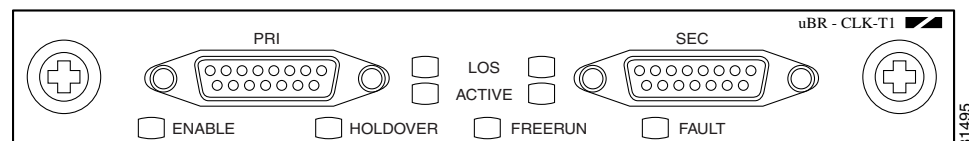

Caution

Do not attempt to remove or install the clock card unless you have first powered off the Cisco uBR7246 VXR.



Note

The Cisco Cable Clock Card does not support an E1 interface.

Clock Source Overview

There are three methods used to acquire and distribute both the primary and secondary national clock sources on the Cisco uBR7246 VXR. Using one of these three methods, the clock card can propagate a national clock signal throughout the chassis midplane to a supported cable interface line card, thus synchronizing communications over all cable interfaces in the Cisco uBR7246 VXR to other routers.

To use a national clock source, the cable interface line card must be one of the following models:

- Cisco uBR-MC16S
- Cisco uBR-MC16E
- Cisco uBR-MC28C
- Cisco uBR-MC28U/X

The three methods used to acquire a national clock signal are:

- Connecting to external T1 source signals from the Public Switched Telephone Network (PSTN)
- Propagating the clock signal from an active T1 connection originating on a port adapter installed in the same Cisco uBR7246 VXR
- Connecting to an external GPS receiver generating the appropriate T1 clock signal

External clock sources must conform to the following minimum specifications:

- Traceable to Stratum 1 clock signal

**Note**

A Stratum 1 clock has a long-term accuracy of 10^{-11} . Stratum 1 clocks are generally used for synchronizing a few master sites in a digital telecommunications network. The synchronized signals propagate the time standard throughout the network.

- Wander on the reference input must not exceed ANSI T1.101 section 7.2.2, time deviation for Type III DS1 reference signals
- Jitter must not exceed the maximum allowable specified in GR-499-CORE section 7.2 for DS1 rates

**Note**

When installed in a Cisco uBR7246 VXR chassis, the clock card operates with a Cisco uBR-MC16S or Cisco uBR-MC16E cable modem card using Cisco IOS Release 12.1(1a)T1 or later, as well as Cisco IOS Release 12.1(2)EC1 or later. The clock card also operates with a Cisco uBR-MC28C cable modem card using Cisco IOS Release 12.1(3a)EC1 or later. You can use other cable interface cards, such as the Cisco uBR-MC16C, with the clock card, but these other cable interfaces will not synchronize their downstream SYNC messages with the external clock source.

Modes of Operation

The clock card can provide timing reference to the Cisco uBR7246 VXR in a number of ways:

- Locked to either primary or secondary signal—The clock card remains in continuous contact with the primary and/or secondary external Stratum 1 clock source until a loss of service occurs, at which time the clock card assumes either holdover or freerun operation. This is the normal mode of operation for the clock card.

- Holdover mode (crystal stabilized)—The clock card enters holdover mode when a loss of service to the current primary and/or secondary external Stratum 1 clock source has occurred, providing that a connection to the external clock source was active and stable for at least 25 seconds. Holdover mode provides a reliable Stratum 3 clock to the Cisco uBR7246 VXR for up to 72 hours after a loss of external service.



Note Holdover mode features 1 ppm maximum drift per day accuracy. A Stratum 3 clock has a long-term accuracy of 10^{-9} .

- Free running crystal source—The clock card enters freerun mode when it is unable to establish reliable service with either the primary or secondary external clock source when the Cisco uBR7246 VXR is powered on. This is the least stable of all operating modes.



Note The clock card features a minimum freerun frequency accuracy of 4.6 ppm.

- Locked to midplane TDM bus clock—If no connection to an external clock source can be established, the clock card can lock on to a T1 clock signal originating from a T1 port adapter installed in the same Cisco uBR7246 VXR and drive the TDM bus, which can then be used by cable modem cards in the Cisco uBR7246 VXR transporting traffic using the TDM bus.

If the primary external clock source experiences a loss of service, the clock card enters holdover mode. After a few seconds of running in holdover mode, the clock card will switch to the secondary external clock source, if one has been connected. The clock card will switch back to the primary external clock source at its first opportunity to restore a reliable connection.

Interface Specifications and Pinouts

The interfaces on the front of the clock card are receive-only DB-15 connectors that enable you to connect your Cisco uBR7246 VXR to external T1 national clock sources originating over the PSTN or a GPS receiver. After you have successfully connected to a primary and or secondary external clock source, you can synchronize data, voice over IP (VoIP) and video communications to other routers around the corner, around the country, and around the world.

The primary and secondary DB-15 interfaces on the front of the clock card connect to external clock signal sources via standard DB-15 T1 interface cables.



Warning

To reduce the risk of fire, use only No. 26 AWG or larger telecommunication line cord.

Figure 1-2 DB-15 T1 Clock Card Interface

Table 1-1 lists connector pinouts for the DB-15 T1 clock card interface.

Table 1-1 DB-15 T1 Clock Card Interface

Clock Card End		External Clock Source End	
Pin ¹	Signal	Pin	Signal
1	Transmit Tip	3	Receive Tip
3	Receive Tip	1	Transmit Tip
9	Transmit Ring	11	Receive Ring
11	Receive Ring	9	Transmit Ring

1. Any pins not described in this table are not connected.

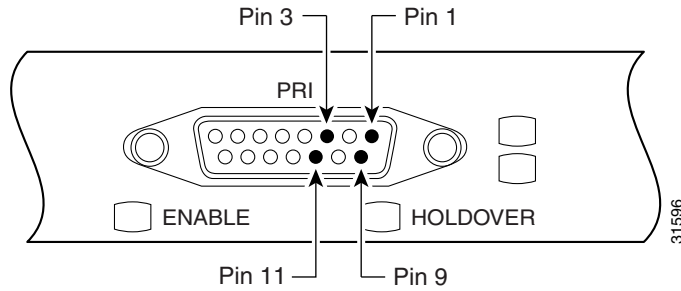
**Note**

Cisco provides DSU/CSU cables. You can use a DA-15 female to pigtail cable, 24.6 feet (7.5 m), CAB-SDS6 cable, COM-T1 Product Number. For pinouts, refer to: <http://www.cisco.com/univercd/cc/td/doc/product/core/cis7505/ipicg/>

LEDs

The clock card features “ACTIVE” and Loss of Service (“LOS”) status indicators for both the primary and secondary clock source connectors. In addition, the clock card features single “ENABLE,” “HOLDOVER,” “FREERUN,” and “FAULT” LEDs. (These LEDs are shown in Figure 1-3.)

Figure 1-3 LEDs on the Clock Card—Faceplate View

Table 1-2 describes the purpose and behavior of each LED on the clock card.

Table 1-2 Clock Card LED Descriptions

LED	Color	Description
LOS (Primary)	Yellow	Indicates that the clock card has lost contact with the primary external clock source.
LOS (Secondary)	Yellow	Indicates that the clock card has lost contact with the secondary external clock source.
ACTIVE (Primary)	Green	Indicates that the clock card is currently locked to the primary external clock source signal.
ACTIVE (Secondary)	Green	Indicates that the clock card is currently locked to the secondary external clock source signal.
ENABLE	Green	Indicates that the clock card is correctly installed in and recognized by the Cisco uBR7246 VXR chassis.
HOLDOVER	Yellow	Indicates that the clock card has lost contact with the current primary and/or secondary external clock source(s) and has entered holdover mode. This means that the clock card was locked to an external clock signal for at least 25 seconds before losing contact and has temporarily become the clock source for the Cisco uBR7246 VXR.
FREERUN	Yellow	Indicates that the clock card has lost contact with both the primary and secondary external clock sources and has inadequate storage from prior connection to enter holdover mode. Unlike holdover mode, entering freerun mode means that the clock card was initially unable to lock on to either a primary or secondary external clock signal. Note Freerun mode is most commonly encountered at startup when the clock card is unable to recognize an external clock source.
FAULT	Amber	Indicates a hardware failure with the clock card circuitry.

Clock Card Location in the Cisco uBR7246 VXR Chassis

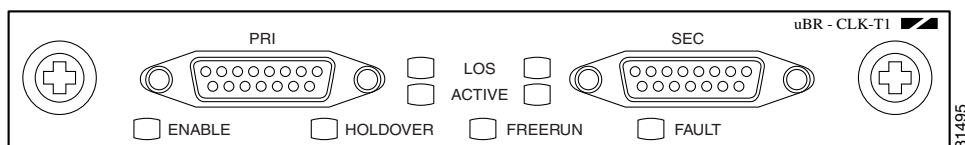
The chassis slot of the Cisco uBR7246 VXR chassis into which the clock card can be installed is on the left side of the chassis immediately below port adapter slot 1. [Figure 1-4](#) shows a Cisco uBR7246 VXR with the clock card installed.

Figure 1-4 Clock Card Location in the Cisco uBR7246 VXR

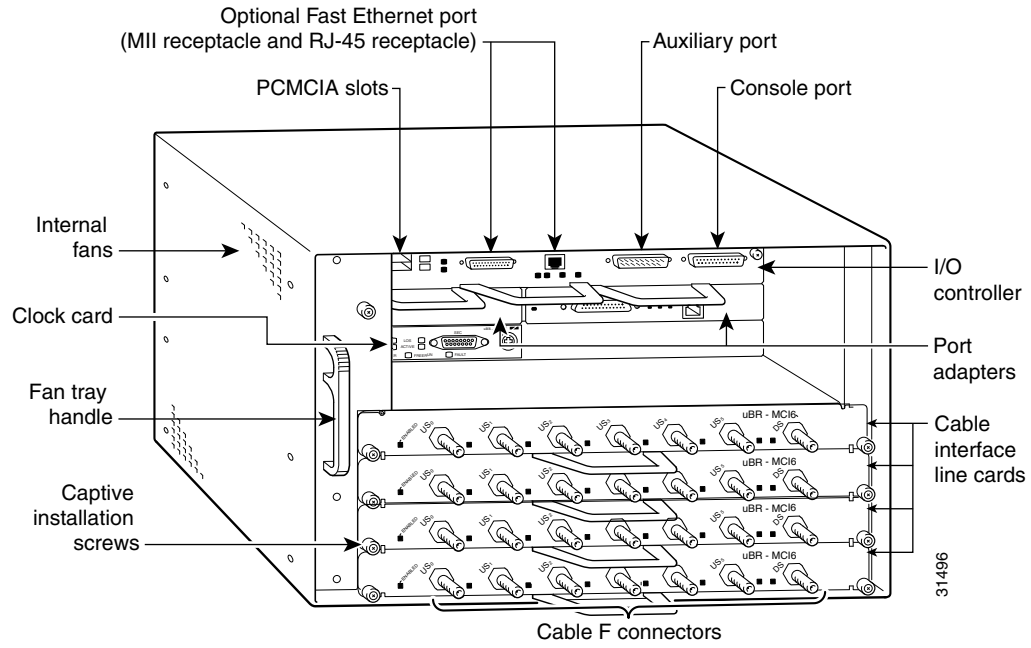



CHAPTER 2

Preparing for Installation

This chapter describes the general equipment, safety, and site preparation requirements for installing the Cisco Cable Clock Card. This chapter contains the following sections:

- [Required Tools and Equipment, page 2-1](#)
- [Software Requirements, page 2-1](#)
- [Safety Guidelines, page 2-2](#)
- [FCC Class A Compliance, page 2-4](#)

Required Tools and Equipment

You need the following tools and parts to install a Cisco Cable Clock Card. If you need additional equipment, contact a service representative for ordering information.

- Cisco uBR7246 VXR universal broadband router
- UBR-CLK-T1(=) Cisco Cable Clock Card
- Cables appropriate for the clock card's interfaces; Cisco provides DSU/CSU cables. You can use a DA-15 female to pigtail cable, 24.6 feet (7.5 m), CAB-SDS6 cable, COM-T1Product Number. For pinouts, refer to:
<http://www.cisco.com/univercd/cc/td/doc/product/core/cis7505/ipicg/>
- Number 2 Phillips screwdriver
- Your own electrostatic discharge (ESD)-prevention equipment or the disposable grounding wrist strap included with all upgrade kits, field-replaceable units (FRUs), and spares
- Antistatic mat
- Antistatic container

Software Requirements

Cisco IOS Release 12.1(1a)T1 or later, as well as Cisco IOS Release 12.1(2)EC1 or later, are the minimum Cisco IOS software releases required to use the clock card with a Cisco uBR-MC16S or Cisco uBR-MC16E cable modem card. Cisco IOS Release 12.1(3a)EC1 or later is the minimum Cisco IOS software release required to use the clock card with a Cisco uBR-MC28C cable modem card.



Note

You can use other cable interface cards, such as the Cisco uBR-MC16C, with the clock card, but these other cable interfaces will not synchronize their downstream SYNC messages with the external clock source.

Safety Guidelines

This section provides safety guidelines that you should follow when working with any equipment that connects to electrical power or telephone wiring.

Safety Warnings

Safety warnings appear throughout this publication in procedures that, if performed incorrectly, might harm you. A warning symbol precedes each warning statement.



Warning

This warning symbol means danger. You are in a situation that could cause bodily injury. Before you work on any equipment, be aware of the hazards involved with electrical circuitry and be familiar with standard practices for preventing accidents. To see translations of the warnings that appear in this publication, refer to the Regulatory Compliance and Safety Information document that accompanied this device.

Waarschuwing

Dit waarschuwingssymbool betekent gevaar. U verkeert in een situatie die lichamelijk letsel kan veroorzaken. Voordat u aan enige apparatuur gaat werken, dient u zich bewust te zijn van de bij elektrische schakelingen betrokken risico's en dient u op de hoogte te zijn van standaard maatregelen om ongelukken te voorkomen. Voor vertalingen van de waarschuwingen die in deze publicatie verschijnen, kunt u het document *Regulatory Compliance and Safety Information* (Informatie over naleving van veiligheids- en andere voorschriften) raadplegen dat bij dit toestel is ingesloten.

Varoitus

Tämä varoitusmerkki merkitsee vaaraa. Olet tilanteessa, joka voi johtaa ruumiinvammaan. Ennen kuin työskentelet minkään laitteiston parissa, ota selvää sähkökytkentöihin liittyvistä vaaroista ja tavanomaisista onnettomuuksien ehkäisykeinoista. Tässä julkaisussa esiintyvien varoitusten käännökset löydät laitteen mukana olevasta *Regulatory Compliance and Safety Information* -kirjasta (määräysten noudattaminen ja tietoa turvallisuudesta).

Attention

Ce symbole d'avertissement indique un danger. Vous vous trouvez dans une situation pouvant causer des blessures ou des dommages corporels. Avant de travailler sur un équipement, soyez conscient des dangers posés par les circuits électriques et familiarisez-vous avec les procédures couramment utilisées pour éviter les accidents. Pour prendre connaissance des traductions d'avertissements figurant dans cette publication, consultez le document *Regulatory Compliance and Safety Information* (Conformité aux règlements et consignes de sécurité) qui accompagne cet appareil.

Warnung

Dieses Warnsymbol bedeutet Gefahr. Sie befinden sich in einer Situation, die zu einer Körperverletzung führen könnte. Bevor Sie mit der Arbeit an irgendeinem Gerät beginnen, seien Sie sich der mit elektrischen Stromkreisen verbundenen Gefahren und der Standardpraktiken zur Vermeidung von Unfällen bewusst. Übersetzungen der in dieser Veröffentlichung enthaltenen Warnhinweise finden Sie im Dokument *Regulatory Compliance and Safety Information* (Informationen zu behördlichen Vorschriften und Sicherheit), das zusammen mit diesem Gerät geliefert wurde.

Avvertenza	Questo simbolo di avvertenza indica un pericolo. La situazione potrebbe causare infortuni alle persone. Prima di lavorare su qualsiasi apparecchiatura, occorre conoscere i pericoli relativi ai circuiti elettrici ed essere al corrente delle pratiche standard per la prevenzione di incidenti. La traduzione delle avvertenze riportate in questa pubblicazione si trova nel documento <i>Regulatory Compliance and Safety Information</i> (Conformità alle norme e informazioni sulla sicurezza) che accompagna questo dispositivo.
Advarsel	Dette varselsymbolet betyr fare. Du befinner deg i en situasjon som kan føre til personskade. Før du utfører arbeid på utstyr, må du være oppmerksom på de faremomentene som elektriske kretser innebærer, samt gjøre deg kjent med vanlig praksis når det gjelder å unngå ulykker. Hvis du vil se oversettelser av de advarslene som finnes i denne publikasjonen, kan du se i dokumentet <i>Regulatory Compliance and Safety Information</i> (Overholdelse av forskrifter og sikkerhetsinformasjon) som ble levert med denne enheten.
Aviso	Este símbolo de aviso indica perigo. Encontra-se numa situação que lhe poderá causar danos físicos. Antes de começar a trabalhar com qualquer equipamento, familiarize-se com os perigos relacionados com circuitos eléctricos, e com quaisquer práticas comuns que possam prevenir possíveis acidentes. Para ver as traduções dos avisos que constam desta publicação, consulte o documento <i>Regulatory Compliance and Safety Information</i> (Informação de Segurança e Disposições Reguladoras) que acompanha este dispositivo.
¡Advertencia!	Este símbolo de aviso significa peligro. Existe riesgo para su integridad física. Antes de manipular cualquier equipo, considerar los riesgos que entraña la corriente eléctrica y familiarizarse con los procedimientos estándar de prevención de accidentes. Para ver una traducción de las advertencias que aparecen en esta publicación, consultar el documento titulado <i>Regulatory Compliance and Safety Information</i> (Información sobre seguridad y conformidad con las disposiciones reglamentarias) que se acompaña con este dispositivo.
Varning!	Denna varningssymbol signalerar fara. Du befinner dig i en situation som kan leda till personskada. Innan du utför arbete på någon utrustning måste du vara medveten om farorna med elkretsar och känna till vanligt förfarande för att förebygga skador. Se förklaringar av de varningar som förekommer i denna publikation i dokumentet <i>Regulatory Compliance and Safety Information</i> (Efterrättelse av föreskrifter och säkerhetsinformation), vilket medföljer denna anordning.

Electrical Equipment Guidelines

Follow these basic guidelines when working with any electrical equipment:

- Before beginning any procedures requiring access to the chassis interior, locate the emergency power-down switch for the room in which you are working.
- Disconnect all power and external cables before moving a chassis; do not work alone when potentially hazardous conditions exist.
- Never assume that power has been disconnected from a circuit; always check.
- Do not perform any action that creates a potential hazard to people or makes the equipment unsafe; carefully examine your work area for possible hazards such as moist floors, ungrounded power extension cables, and missing safety grounds.

Preventing Electrostatic Discharge Damage

Electrostatic discharge (ESD) damage, which can occur when electronic cards or components are improperly handled, results in complete or intermittent failures. Port adapters and processor modules comprise printed circuit boards that are fixed in metal carriers. Electromagnetic interference (EMI) shielding and connectors are integral components of the carrier. Although the metal carrier helps to protect the board from ESD, use a preventive antistatic strap during handling.

Following are guidelines for preventing ESD damage:

- Always use an ESD wrist or ankle strap and ensure that it makes good skin contact.
- Connect the equipment end of the strap to an unfinished chassis surface.
- When installing a component, use any available ejector levers or captive installation screws to properly seat the bus connectors in the backplane or midplane. These devices prevent accidental removal, provide proper grounding for the system, and help to ensure that bus connectors are properly seated.
- When removing a component, use any available ejector levers or captive installation screws to release the bus connectors from the backplane or midplane.
- Handle carriers by available handles or edges only; avoid touching the printed circuit boards or connectors.
- Place a removed component board-side-up on an antistatic surface or in a static shielding container. If you plan to return the component to the factory, immediately place it in a static shielding container.
- Avoid contact between the printed circuit boards and clothing. The wrist strap only protects components from ESD voltages on the body; ESD voltages on clothing can still cause damage.
- Never attempt to remove the printed circuit board from the metal carrier.



Caution

For safety, periodically check the resistance value of the antistatic strap. The measurement should be between 1 and 10 megohms (Mohm).

FCC Class A Compliance

The equipment described in this manual has been tested and found to comply with the limits for a Class A digital device. These limits are designed to provide reasonable protection against harmful interference when the equipment is operated in a commercial environment. This equipment generates, uses, and can radiate radio-frequency energy and, if not installed and used in accordance with the instruction manual, may cause harmful interference to radio communications. Operation of this equipment in a residential area is likely to cause harmful interference, in which case users will be required to correct the interference at their own expense.

You can determine whether your equipment is causing interference by turning it off. If the interference stops, it was probably caused by the Cisco equipment or one of its peripheral devices. If the equipment causes interference to radio or television reception, try to correct the interference by using one or more of the following measures:

- Turn the television or radio antenna until the interference stops.
- Move the equipment to one side or the other of the television or radio.
- Move the equipment farther away from the television or radio.
- Plug the equipment into an outlet that is on a different circuit from the television or radio. (That is, make certain the equipment and the television or radio are on circuits controlled by different circuit breakers or fuses.)



Note

The clock card has been designed to meet these requirements. Modifications to this product that are not authorized by Cisco Systems could void the approvals and negate your authority to operate the product.



CHAPTER 3

Removing and Installing the Clock Card

This chapter describes how to remove the Cisco Cable Clock Card from a Cisco uBR7246 VXR and also how to install a new or replacement clock card. This chapter contains the following sections:

- [Installation Overview, page 3-1](#)
- [Handling the Clock Card, page 3-2](#)
- [Online Insertion and Removal, page 3-2](#)
- [Warnings and Cautions, page 3-2](#)
- [Clock Card Removal and Installation, page 3-3](#)
- [Connecting a Clock Card Interface Cable, page 3-6](#)

Installation Overview

Each clock card circuit board is mounted to a metal carrier and is sensitive to electrostatic discharge (ESD) damage.



Note

When the clock card slot is not in use, a blank clock card must fill the empty slot to allow the router or switch to conform to electromagnetic interference (EMI) emissions requirements and to allow proper airflow across all of the universal broadband router's components. If you plan to install a new clock card in a slot that is not in use, you must first remove the blank clock card.

Handling the Clock Card

**Caution**

Always handle the clock card by the carrier edges and handle; never touch the clock card's components or connector pins. (See [Figure 3-1](#).)

Figure 3-1 Handling a Clock Card

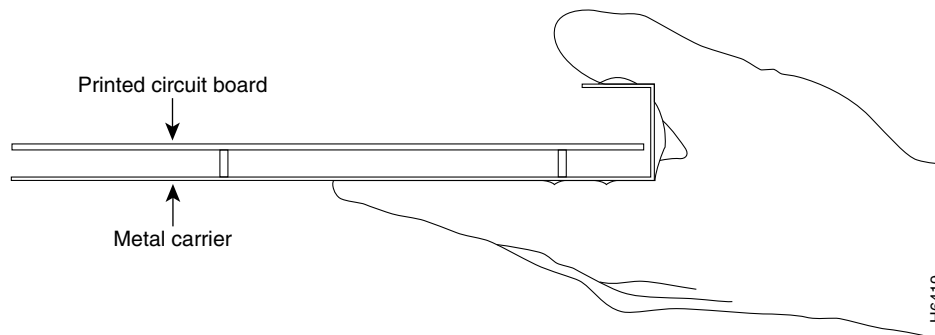

Online Insertion and Removal

The Cisco uBR7246 VXR supports online insertion and removal (OIR), however, the clock card cannot be “hot-swapped” in the chassis. You must power down the Cisco uBR7246 VXR when removing and/or replacing a clock card. Removing the clock card from the chassis before powering off will cause the router to crash.

**Note**

Before you begin installation, read [Chapter 2, “Preparing for Installation”](#) for a list of parts and tools required for installation.

Warnings and Cautions

Observe the following warnings and cautions when installing or removing the clock card.

**Caution**

Do not attempt to remove or install the clock card unless you have first powered off the Cisco uBR7246 VXR.

**Caution**

Do not connect the primary and/or secondary DB-15 T1 cables until the clock card has been installed in the Cisco uBR7246 VXR.

**Note**

If the clock card installation screws do not appropriately assume a locked position, the clock card is not completely seated in the midplane. Carefully pull the clock card halfway out of the slot, reinsert it, and tighten the captive installation screws.

**Caution**

To prevent jamming the carrier between the upper and the lower edges of the clock card slot, and to ensure that the edge connector at the rear of the clock card mates with the connection at the rear of the clock card slot, make certain that the carrier is positioned correctly, as shown in the cutaway in the following illustrations.

**Warning**

When performing the following procedures, wear a grounding wrist strap to avoid ESD damage to the card. Some platforms have an ESD connector for attaching the wrist strap. Do not directly touch the midplane or backplane with your hand or any metal tool, or you could shock yourself.

**Warning**

To reduce the risk of fire, use only No. 26 AWG or larger telecommunication line cord.

Clock Card Removal and Installation

In this section, the illustrations that follow give step-by-step instruction on how to remove and install the clock card. This section contains the following illustrations:

- [Cisco uBR7246 VXR—Removing a Clock Card, page 3-4](#)
- [Cisco uBR7246 VXR—Installing a Clock Card, page 3-5](#)

Cisco uBR7246 VXR—Removing a Clock Card

Step 1

Power off the Cisco uBR7246 VXR.

Step 2

Disconnect the DB-15 T1 cable(s) from the front of the clock card.

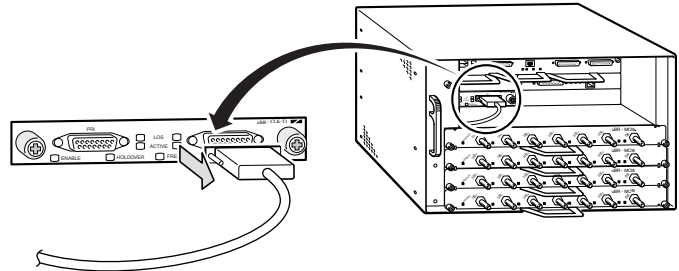

Step 3

Unscrew the captive installation screws on the front of the clock card.

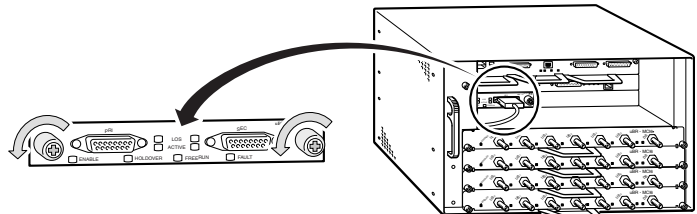

Step 4

Carefully pull the clock card out of its chassis slot.

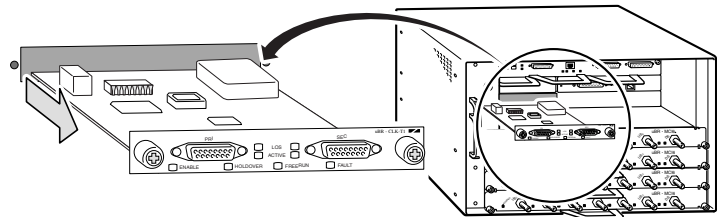

Step 5

Place the clock card on an antistatic surface with its components facing upward, or in a static shielding bag. If the clock card will be returned to the factory, immediately place it in a static shielding bag.

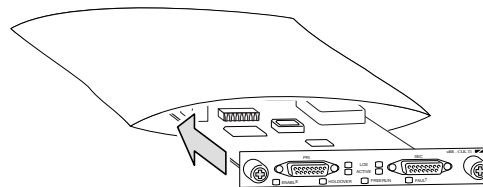

31511

Cisco uBR7246 VXR—Installing a Clock Card

Step 1

Ensure that the Cisco uBR7246 VXR is powered off.

Step 2

Align the left and right edges of the clock card printed circuit board between the guides in its chassis slot.

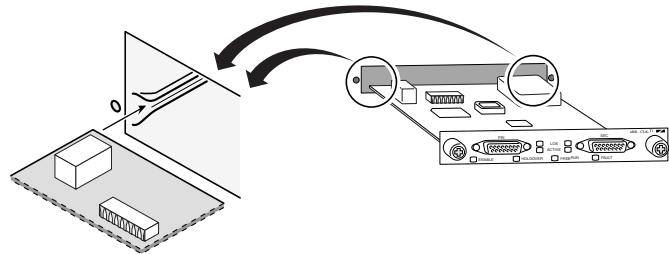

Step 3

With the printed circuit board aligned in the slot guides, gently slide the clock card into its chassis slot.

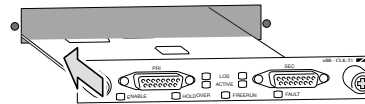

Step 4

Tighten the captive installation screws on the clock card.

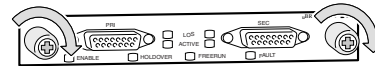

Step 5

Connect the DB-15 T1 cable(s) to the front of the clock card.

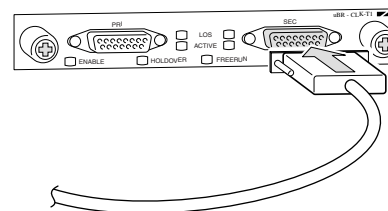

31512

Connecting a Clock Card Interface Cable

You can use up to two DB-15 T1 connections on the clock card. They are available from Cisco Systems and outside commercial cable vendors.

To connect DB-15 T1 cables to the clock card, follow these steps:

- Step 1** Attach the DB-15 T1 cable directly to either the primary or secondary DB-15 interface port on the clock card. (See [Figure 3-2](#).)



Note

When attaching the cable receptacle on the clock card, use the cable-management bracket that shipped with your router for extra strain relief.

Figure 3-2 Connecting a Clock Card Cable—Front View

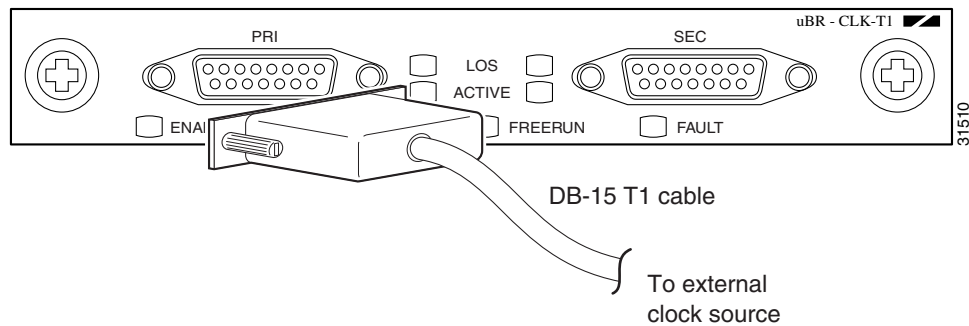

- Step 2** Attach the network end of your DB-15 T1 cable to your CSU/DSU, DTE, or other external equipment.
- Step 3** Repeat Steps 1 and 2 for the other DB-15 T1 interface.

This completes the procedure for attaching a DB-15 T1 cable to the clock card. Proceed to [Chapter 4](#), “Configuring the Clock Card.”



CHAPTER 4

Configuring the Clock Card

To continue the Cisco Cable Clock Card installation, you must configure the primary and/or secondary T1 interfaces. This chapter contains the following sections:

- [Minimum Software Requirements, page 4-1](#)
- [Configuration and Diagnostic Cisco IOS Commands for the Clock Card, page 4-2](#)

Minimum Software Requirements

You must have Cisco IOS Release 12.1(1a)T1 or later, and Cisco IOS Release 12.1(2)EC1 or later if you are configuring the clock card with a Cisco uBR-MC16S or Cisco uBR-MC16E cable interface line card. If you are using a Cisco uBR-MC28C cable interface line card with the clock card, you must use Cisco IOS Release 12.1(3a)EC1 or later. If you are using a Cisco uBR-MC28U/X card, you must use Cisco IOS Release 12.2(15)CX or later.



Note

You can use other cable interface cards, such as the Cisco uBR-MC16C, with the clock card, but these other cable interfaces will not synchronize their downstream SYNC messages with the external clock source.

Configuration and Diagnostic Cisco IOS Commands for the Clock Card

Table 4-1 presents a list of basic configuration and diagnostic Cisco IOS commands that you can use to initially configure and troubleshoot clock card installation. For complete command-line syntax examples and more definitive explanations of command-line functions, refer to the *Cisco uBR7200 Series Universal Broadband Router Software Configuration Guide*.

Table 4-1 Cisco IOS Commands for the Clock Card and Their Descriptions

Command Line	Description
Exec Commands	
show cable clock	Displays clock card status information like primary and secondary connections' source and status, timestamp reference information, current clock card mode of operation, any hardware fault, and the midplane clock signal source, if active.
show controllers clock-reference	Displays clock card hardware information and current register values.
cable clock clear-counters	Instructs the router to reset the counters displayed by the show controllers clock-reference command.
Config Commands	
[no] cable clock source-midplane	Instructs the clock card to lock on to and propagate the router's internal TDM midplane clock signal.
[no] cable clock force {primary secondary}	Forces activation or deactivation of the primary or secondary interface. (Cannot be executed if holdover mode is not possible.)
Support Commands	
show version	Displays critical information about the router, including the presence of a clock card, if one is installed.
show tech-support	Prints information regarding the router's current status, including the clock card timing reference, if a clock card is installed.
show diag	Displays diagnostic information about the router, including critical clock card information, if a clock card is installed.



APPENDIX **A**

Clock Source Paths

The schematics in this appendix display the various clock source paths established by the Cisco Cable Clock Card in a Cisco uBR7246 VXR depending on your external connection(s) and configuration.

Figure A-1 Primary External Clock Source

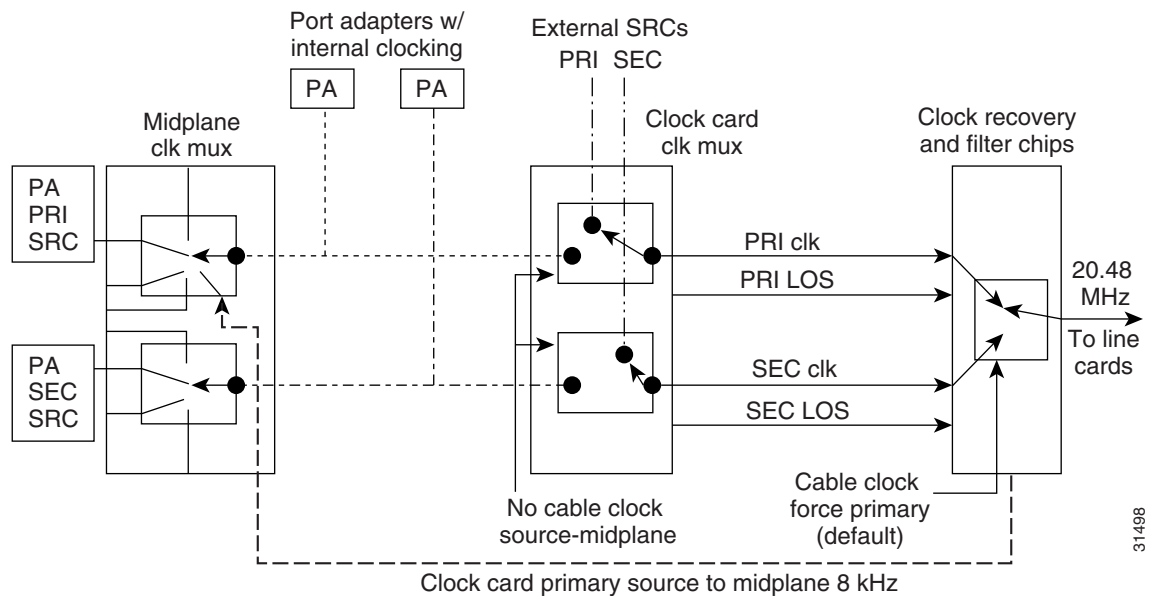

31498

Figure A-2 Secondary External Clock Source

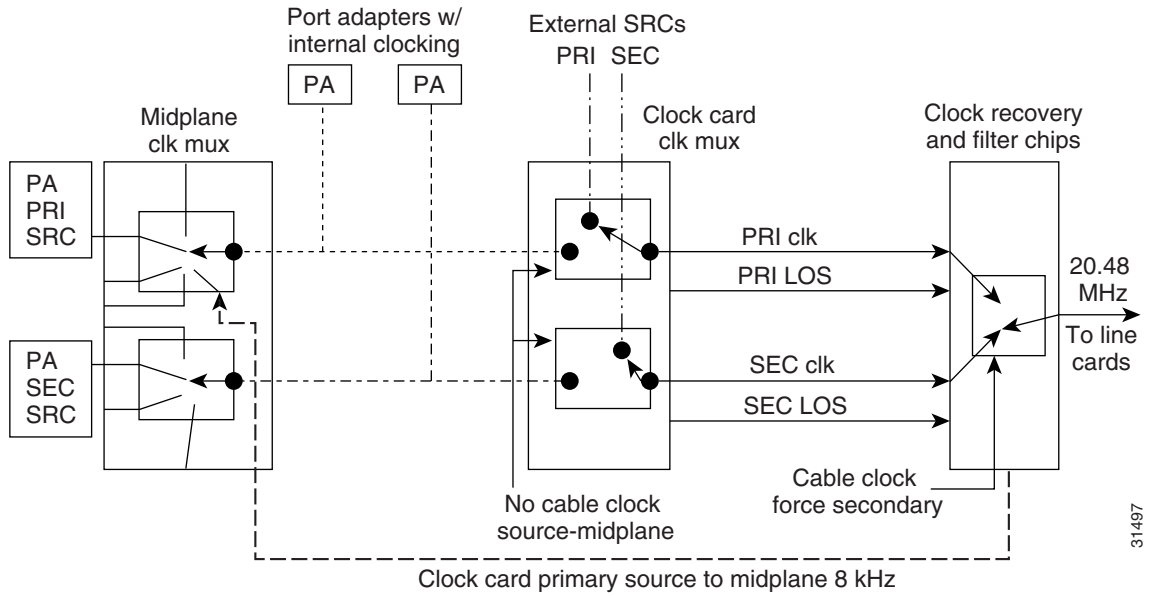

31497

Figure A-3 Secondary External Clock Source Driving Midplane

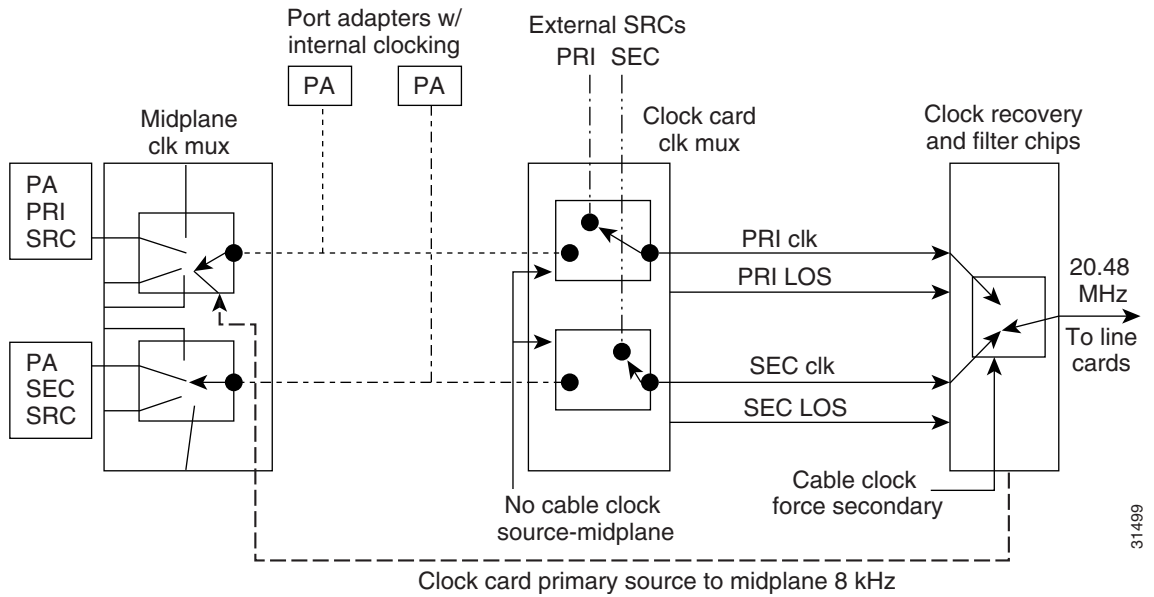

31499

Figure A-4 Secondary Internal Clock Source

