



## CHAPTER 4

# Implementing and Configuring the Solution

---

This chapter provides implementation and configuration information for the Cisco DOCSIS 3.0 Downstream Solution, for Cisco IOS Release 12.3(23)BC and 12.2(33)SCB, and contains the following topics:

- [Wideband CMTS Configuration, page 4-1](#)
- [Wideband Cable Modem Behavior, page 4-5](#)
- [Cisco SIP-600 and Gigabit Ethernet SPA Configuration, page 4-10](#)
- [Supported MIBs, page 4-10](#)
- [Known Restrictions, page 4-12](#)

## Wideband CMTS Configuration

This section provides overview information on the wideband CMTS configuration tasks:

- [Configuring Base CMTS Components, page 4-1](#)
- [Configuring Wideband CMTS Components, page 4-2](#)

This section also lists documents where you can find the detailed information needed to configure the Cisco IOS software for the Cisco uBR10012 router components, including the components needed for the Cisco DOCSIS 3.0 Downstream Solution, Release 2.0.

## Configuring Base CMTS Components

The base CMTS is the Cisco uBR10012 router with the components needed for DOCSIS 1.x/2.0 and DOCSIS 3.0 operations. Wideband cable components can be added to the Cisco uBR10012 base system so that it can be used as a wideband CMTS. For wideband cable operation, the configuration tasks for the base CMTS components are similar to the configuration tasks used for DOCSIS 1.x/2.0 and DOCSIS 3.0 operations. The base CMTS can be used as a DOCSIS 1.x/2.0 and DOCSIS 3.0 CMTS.

All wideband channels used on a fiber node and all associated primary downstream channels on Cisco uBR10-MC5X20 cable interface line cards must be configured to belong to the same virtual bundle interface. For detailed information on this configuration task, see the “Configuring a Virtual Bundle” section in the *Cisco uBR10012 Universal Broadband Router SIP and SPA Software Configuration Guide*.

[Table 4-1](#) provides a list of the software configuration documents that are likely to be useful for configuring the Cisco DOCSIS 3.0 Downstream Solution, Release 2.0 base CMTS components.

**Table 4-1 Base CMTS Components Configuration: Where to Find Information**

<b>Solution Component</b>	<b>Where to Find Information</b>
Cisco uBR10012 router (general and feature-specific configuration)	<a href="#">Release Notes for Cisco uBR10012 Universal Broadband Router for Cisco IOS Release 12.3 BC</a> (which includes information on Cisco IOS Release 12.3(21)BC)  <a href="#">Cisco uBR10012 Universal Broadband Router Software Configuration Guide</a>  <a href="#">Cisco Cable Modem Termination System Feature Guide</a>
Performance Routing Engine 2 (PRE2)	<a href="#">Route Processor Redundancy Plus for the Cisco uBR10012 Universal Broadband Router</a>
Cisco uBR10-MC5X20 line cards	Chapter 3, “Configuring Cable Interface Features for the Cisco uBR10012 Router,” in the <a href="#">Cisco uBR10012 Universal Broadband Router Software Configuration Guide</a>  “Cable Interface Bundling and Virtual Interface Bundling for the Cisco CMTS” in the <a href="#">Cisco Cable Modem Termination System Feature Guide</a>  “N+1 Redundancy for the Cisco Cable Modem Termination System” in the <a href="#">Cisco Cable Modem Termination System Feature Guide</a>
Half-Height Gigabit Ethernet (HHGE) network uplink line cards	<a href="#">Configuring the Half-Height Gigabit Ethernet Line Card for the Cisco uBR10012 Universal Broadband Router</a>

The technical documentation set for the Cisco uBR10012 router includes many documents not shown in [Table 4-1](#) that are useful for configuring the CMTS. The Cisco uBR10012 documentation set can be accessed from this url:

[http://www.cisco.com/en/US/products/hw/cable/ps2209/tsd\\_products\\_support\\_series\\_home.html](http://www.cisco.com/en/US/products/hw/cable/ps2209/tsd_products_support_series_home.html)

## Configuring Wideband CMTS Components

The wideband CMTS components are added to the base CMTS components to make the CMTS wideband-capable. This section provides overview information on configuring the wideband CMTS components:

- [Configuring the Wideband SIP and Wideband SPA, page 4-2](#)
- [Configuring the DOCSIS Timing and Control Card, page 4-3](#)
- [Configuring the Edge QAM Device, page 4-3](#)
- [Configuring the Gigabit Ethernet Switch, page 4-5](#)
- [Configuring the DTI Server, page 4-5](#)

### Configuring the Wideband SIP and Wideband SPA

The wideband CMTS components that require configuration include the Cisco Wideband SIP and Cisco Wideband SPA. Cisco IOS commands are issued on the Cisco uBR10012 router to configure the Wideband SIP and Wideband SPA. An outline of the configuration tasks needed for the Wideband SIP and Wideband SPA is as follows:

- Preprovisioning of the Wideband SIP and Wideband SPA
- Setting general configuration values for the Wideband SPA
- Configuring narrowband channels
- Configuring Wideband Channels
- Configuring the Channel Grouping Domain
- Configuring wideband channels and the CGD host interface as Virtual Bundle Members
- Setting optional configuration values
- Selecting primary downstream channels

For information on the preceding tasks and for reference information on the Cisco IOS commands used for Wideband SIP and Wideband SPA configuration, see the *Cisco uBR10012 Universal Broadband Router SIP and SPA Software Configuration Guide*.

## Configuring the DOCSIS Timing and Control Card

The DOCSIS Timing and Control Card (DTCC), which acts as the DTI client, provides the interface to the DTI server for the CMTS. By default, the DTCC runs in a standalone mode and does not synchronize its timing to the external DTI server. The DTCC must be configured to operate as a DTI Client. For information on the task of configuring the DTCC to operate as a DTI Client, see the *Cisco uBR10012 Universal Broadband Router DTCC* documentation.

## Configuring the Edge QAM Device

Edge QAM (EQAM) device configuration is device-specific and implementation-specific. Refer to the device's documentation for configuration information.

Regardless of the EQAM device or implementation, these items are used for Wideband SPA configuration and must be configured on each EQAM device:

- For the edge QAM device:
  - IP address of the EQAM device's Gigabit Ethernet interface (input port)
  - MAC address of the EQAM device's Gigabit Ethernet interface (input port)
- For each of the EQAM device's QAM outputs that will be used for a Wideband SPA DS channel:
  - Center frequency of the QAM output
  - UDP number of the QAM output
  - DEPI remote ID of the QAM output

The IP address, MAC address, frequency, and UDP port or DEPI configured on the edge QAM device are specified when configuring RF channels on the CMTS. Be certain to verify that the RF channel values set with **rf-channel** (issued on the CMTS) match the values configured on the edge QAM device.



### Note

If a Layer 2 Gigabit Ethernet switch is used to connect the Wideband SPA to the EQAM device, the MAC address specified in the **rf-channel** command is the MAC address of the switch's Gigabit Ethernet interface.

**Note**

The EQAM device may also require configuration to connect to a DTI server. For information on configuring the EQAM device, refer to the vendor EQAM device documentation.

An RF channel and EQAM configuration worksheet such as the one shown in [Table 4-2](#) may be useful for coordinating Wideband SPA RF channel and EQAM device configuration. A Wideband SPA supports either 18 or 24 RF channels depending on how the SPA is configured. For more information, see the description of the **rf-channel** command in the *Cisco uBR10012 Universal Broadband Router SIP and SPA Software Configuration Guide*.

**Table 4-2 RF Channel and EQAM Configuration Worksheet**

Wideband SPA RF Channel	EQAM Device		QAM Output			DEPI Remote ID
	GE Input IP Address	GE Input MAC Address	QAM Output	Frequency	UDP Port Number	
0						
1						
2						
3						
4						
5						
6						
7						
8						
9						
10						
11						
12						
13						
14						
15						
16						
17						
18						
19						
20						
21						
22						
23						

## Configuring the Gigabit Ethernet Switch

A Gigabit Ethernet (GE) switch linking the Cisco Wideband SPAs and the edge QAM (EQAM) devices is optional except when more than two EQAM devices are required for two Wideband SPAs, or when video-on-demand (VOD) traffic and the RF channels for wideband channels are mixed on the same EQAM device. The configuration of the Gigabit Ethernet switch is device-specific and implementation-specific, but it is recommended that virtual LANs (VLANs) be used to create separate broadcast domains for the traffic of each Wideband SPA.

Figure 4-1 shows an example of VLAN usage. Wideband SPA 1 uses the QAM outputs on EQAM A and EQAM B. Wideband SPA 2 uses the QAM outputs on EQAM C and EQAM D.

- VLAN 1 carries traffic for Wideband SPA 1.
- VLAN 2 carries traffic for Wideband SPA 2.

Both the Wideband SPAs and EQAM devices have redundant Gigabit Ethernet links that are members of the appropriate VLANs.

**Figure 4-1** VLANs for Wideband Traffic

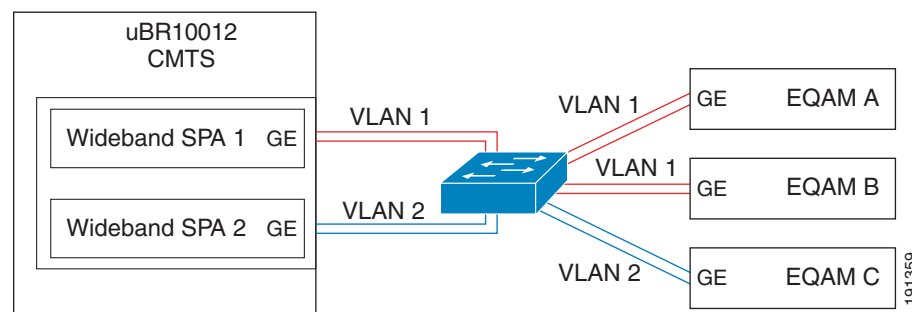

## Configuring the DTI Server

The DTI server provides the DOCSIS time stamp and frequency to the DTI clients. The DTI server mode and Time Of Day (TOD) services are configurable. The TOD services can be configured to be the internal Real Time Clock (RTC) or it can be updated from Global Positioning System (GPS). For information on configuring the DTI server, see the vendor DTI server device documentation.

## Wideband Cable Modem Behavior

This section provides information on the wideband cable modems and their interactions with the CMTS. The following topics are discussed:

- [Linksys WCM300-NA, WCM300-EURO, and WCM300-JP Modems, page 4-6,](#)
- [Scientific Atlanta DPC2505 and EPC2505 Wideband Cable Modems, page 4-8](#)
- [CMTS Interactions with Scientific Atlanta DPC2505 and EPC2505, page 4-8](#)

## Linksys WCM300-NA, WCM300-EURO, and WCM300-JP Modems

With the Linksys WCM300-NA, WCM300-EURO, and WCM300-JP wideband cable modems, the Cisco DOCSIS 3.0 Downstream Solution supports downstream data service to the cable modem on multiple bonded downstream channels. The Linksys WCM300 wideband cable modem supports the receiving of up to three wideband downstream channels:

- One primary bonded channel
- Up to two secondary bonded channels

The primary bonded channel is the wideband channel on which the wideband cable modem receives all of its unicast traffic and some multicast traffic. The cable modem may identify the primary bonded channel and any secondary bonded channels to the CMTS at cable modem registration time. The DOCSIS configuration file may define the primary bonded channel for the CMTS to assign to the cable modem.

Secondary bonded channels are the wideband channels on which the wideband cable modem receives additional multicast data streams. The DOCSIS configuration file defines the secondary bonded channels for the modem to pass to the CMTS. Secondary bonded channels are intended to receive multicast traffic such as broadcast video that is not available on the primary bonded channel.

When the wideband cable modem registers with one primary and one or more secondary wideband channels, it accepts multicast packets from all associated wideband channels. The CMTS ensures that a multicast packet is not forwarded on the primary and secondary wideband channels simultaneously.

A primary bonded channel cannot also be configured as a secondary bonded channel, and vice versa. Primary and secondary bonded channels can be configured on the CMTS with the **cable bonding-group-id** command and with the DOCSIS configuration file using TLVs (primary bonding group ID and secondary bonding group ID).

The Linksys WCM300 wideband cable modem implements a subset of the DOCSIS 3.0 protocol for channel bonding. Channel bonding is accomplished by the use of a per-packet sequence number to enable the wideband cable modem to deliver, in order, the packets from multiple RF channels that are destined to the CPE device. The Linksys WCM300 modem supports up to 16 independent resequencing engines for the receiving of bonded unicast traffic and bonded multicast traffic over its three bonded channels.

## DOCSIS Configuration File for Wideband on Linksys WCM300 Modems

The Linksys WCM300 wideband cable modem obtains a DOCSIS configuration file as it does in DOCSIS 3.0. For wideband operation, the file may contain three wideband-related Type/Length/Value (TLV) encodings:

- Primary bonding group ID
- Bonded channel enable
- Secondary bonding group ID



**Note** The preceding TLVs can be optionally specified in the DOCSIS configuration file. These TLVs *are not required* for the Linksys WCM300 modem to operate in wideband mode (w-online).

All three TLVs are encoded as vendor-specific options (type 43) to facilitate interoperability and reduce future compatibility issues.

## Primary Bonding Group ID

The primary bonding group ID option is encoded as subtype 14:

- Type.Subtype: 43.14
- Length: 2
- Value: primary bonding group ID

The primary bonding group ID option allows the provisioning system to force the wideband cable modem to use a particular primary bonded downstream channel. The modem can use a single primary bonded channel for unicast and multicast traffic. When the primary bonding group ID value is present, the CMTS assigns the wideband cable modem to the wideband-channel interface identified by the configured bonding group ID. If the CMTS is unable to assign the wideband cable modem to the wideband-channel interface specified by the configured bonding group ID, the CMTS causes the wideband cable modem to fail registration.

Only a single occurrence of the primary bonding channel ID option may be specified in the DOCSIS configuration file. The total of the RF channels in the primary and secondary bonded channels must comply with the 50-MHz capture-window limitation of the Linksys WCM300 modem.



### Note

When a wideband channel is specified as a primary bonded channel in the DOCSIS configuration file, the channel must be identically specified as a primary bonded channel in the CMTS active, running configuration file. The **cable bonding-group-id** command specifies whether a bonding group is a primary or secondary bonding group. For information on this command, see the *Cisco uBR10012 Universal Broadband Router SIP and SPA Software Configuration Guide*.

## Bonded Channel Enable

The bonded channel enable option is encoded as subtype 15:

- Type.Subtype: 43.15
- Length: 1
- Value: 0 equals Disable, and 1 equals Enable

The bonded channel enable option allows the provisioning system to require that a wideband cable modem operate in DOCSIS 2.0 mode. When the bonded channel enable option has a value of 0 (disable), the CMTS ensures that a wideband-channel interface is not assigned to the wideband cable modem at registration time.

Only a single occurrence of the bonded channel enable option may be specified in the DOCSIS configuration file.

## Secondary Bonding Group ID

The secondary bonding group ID option is encoded as subtype 16:

- Type.Subtype: 43.16
- Length: 2
- Value: secondary bonding group ID

The secondary bonding group ID option allows the provisioning system to specify secondary bonded downstream channels for the wideband cable modem to use. The modem can use one or two secondary bonded channels for multicast traffic. If the configured secondary bonding group ID is not valid, the CMTS causes the wideband cable modem to fail registration.

Up to two secondary bonding group IDs can be specified in the DOCSIS configuration file. The total of the RF channels in the primary and secondary bonded channels must comply with the 50 MHz capture-window limitation of the Linksys WCM300 modem.

**Note**

When a wideband channel is specified as a secondary bonded channel in the DOCSIS configuration file, the channel must be identically specified as a secondary bonded channel in the CMTS active, running configuration file. The **cable bonding-group-id** command specifies whether a bonding group is a primary or secondary bonding group. For information on this command, see the *Cisco uBR10012 Universal Broadband Router SIP and SPA Software Configuration Guide*.

## Scientific Atlanta DPC2505 and EPC2505 Wideband Cable Modems

**Note**

All interactions and behaviors described in this section for the Scientific Atlanta DPC2505 wideband cable modem are also applicable to the Scientific Atlanta EPC2505 wideband cable modem.

The Scientific Atlanta DPC2505 (EPC2505 for EuroDOCSIS) wideband cable modem makes use of the Broadcom Corporation BCM93381 cable modem chip. The BCM93381 chip provides three tuners, allowing the three downstream receivers to be independently tuned to any frequency. The M-CMTS and the Scientific Atlanta DPC2505 wideband cable modem use three downstream RF channels from the SPA, one of which is the primary downstream channel, to form a wideband channel. The primary downstream channel is used for SYNCs, MAPs and other MAC management messages.

The Scientific Atlanta DPC2505 wideband cable modem uses a selected subset of the DOCSIS 3.0 protocol for channel bonding. Channel bonding is the transmission of a stream of packets across multiple RF channels with the use of sequence numbers to ensure the modem receiver delivers packets in the proper order to the CPE. The Scientific Atlanta DPC2505 wideband cable modem filters packets on a Destination Address and Security Association Identifier (SAID). The Scientific Atlanta DPC2505 modem supports up to 16 independent resequencing contexts.

The Scientific Atlanta DPC2505 wideband cable modem does not support multicast traffic on the wideband channel. Multicast service flows that the modem sees on the bonded downstream channel are discarded.

The configuration file used for the Scientific Atlanta DPC2505 wideband cable modem is identical to a DOCSIS 3.0 configuration file. DOCSIS 3.0 configuration file tools like the Cisco Broadband Configurator can be used to create configuration files for this modem.

## CMTS Interactions with Scientific Atlanta DPC2505 and EPC2505

For the Scientific Atlanta DPC2505 and EPC2505 wideband cable modems, this section provides information on the following:

- [Registration for Scientific Atlanta DPC2505, page 4-9](#)
- [Automatic Adjustments During Scientific Atlanta DPC2505 Registration, page 4-9](#)
- [Load Balancing for Scientific Atlanta DPC2505, page 4-10](#)

In these sections, all statements that apply to the Scientific Atlanta DPC2505 modem also apply to the Scientific Atlanta EPC2505 modem.

## Registration for Scientific Atlanta DPC2505

After the Scientific Atlanta DPC2505 wideband cable modem completes the initialization process on the primary downstream channel, the CMTS uses the REG-RSP message to enable multiple downstream RF channel operation (wideband channel operation) and to assign channels to the cable modem.

Consistent with DOCSIS 3.0, the assignment of multiple channels takes place at two layers. The lower layer is that of physical receiver configuration, or the Receive Channel Set, of the cable modem. The CMTS uses a specific subset of DOCSIS 3.0 Receive Channel Configuration (RCC) encodings to tell the wideband cable modem what center frequencies to use for its primary downstream channel receiver and its two non-primary downstream channel receivers.

With the Scientific Atlanta DPC2505 wideband cable modem as per DOCSIS 3.0, bonding and sequencing of traffic can take place across all channels of a cable modem's Receive Channel Set, or across any subset of these channels. A second, higher layer of channel assignment deals with bonding and resequencing. This higher layer is handled by assignment of a Downstream Service Identifier (DSID) for each independent sequence number space. In the REG-RSP message, the CMTS uses a subset of DOCSIS 3.0 DSID encodings to tell the cable modem the DSID values to recognize and the channels and resequencing timeouts that are associated with each DSID.

## Automatic Adjustments During Scientific Atlanta DPC2505 Registration

Upon reception of the REG-RSP, the Scientific Atlanta DPC2505 modem first checks for presence and correctness of the various encodings.

- If any encodings are incorrectly formatted or exceed the modem's capabilities, the wideband cable modem may detect this and immediately send a REG-ACK message with a confirmation code indicating failure. The confirmation code will be reject-bad-rcc(208) if the RCC encoding is bad, or reject-other(1) if some other problem is found.
- If encodings appear to be valid, the wideband cable modem attempts to tune its non-primary receivers to the non-primary downstream channels specified in the RCC. The RCC may specify zero, one, or two non-primary downstream channels. If the cable modem fails to tune to the designated non-primary downstream channels, it will send a REG-ACK message with confirmation code reject-bad-rcc(208).

In the case of wideband channels overlapping on some sets of QAM channels, if the Scientific Atlanta DPC2505 modem rejects the registration with confirmation code of reject-bad-rcc(208), something is wrong— either an incorrect plant topology configuration or a bad tuner in the cable modem. The CMTS records this occurrence. When the same cable modem tries to register again, the CMTS chooses different wideband channels preferably residing on a different sets of QAM channels.

The process continues until the wideband cable modem successfully registers on a wideband channel or all choices of wideband channels are exhausted. If all choices are exhausted, the Scientific Atlanta DPC2505 modem operates as a narrowband modem on its next attempt to register.

A timeout value of 24 hours is defined for the CMTS to clear the bad QAM status recorded for each cable modem. Therefore, the wideband cable modem is allowed to retry the bad set of QAM channels in the future.

## Load Balancing for Scientific Atlanta DPC2505

If multiple wideband channels are available on the same fiber node, and the Scientific Atlanta DPC2505 wideband cable modem comes online with one of the wideband channels, the CMTS has the choice of assigning it to a different wideband channel. In this case, a simple random load balancing algorithm distributes the cable modems on the fiber node across the multiple wideband channels.

If the CMTS has a choice between a wideband channel consisting of one RF channel and another channel consisting of two RF channels, the CMTS uses a weighted random load-balancing algorithm to determine the wideband channel that the wideband cable modem will use. The wideband channel with two RF channels is weighted so that it has two-thirds of a chance of being chosen while the wideband channel with one RF channel has one-third of a chance.

For more information on load balancing, refer to the *Cisco uBR10012 Universal Broadband Router SIP and SPA Software Configuration Guide*.

## Cisco SIP-600 and Gigabit Ethernet SPA Configuration

This section mentions the configuration tasks related to the Cisco SIP-600 and Gigabit Ethernet SPA:

- [Configuring the Cisco SIP-600, page 4-10](#)
- [Configuring the Gigabit Ethernet SPAs, page 4-10](#)

### Configuring the Cisco SIP-600

The Cisco 10000 Series SPA Interface Processor-600 (referred to as the Cisco SIP-600) can support up to six Cisco Wideband SPAs. For more configuration information, see the chapter “Configuring a SIP” in the *Cisco uBR10012 Universal Broadband Router SIP and SPA Software Configuration Guide*.

### Configuring the Gigabit Ethernet SPAs

The following Gigabit Ethernet SPAs are supported on the Cisco 10000 SIP-600 on the Cisco uBR10012 router in the Cisco IOS Release 12.2(33)SCB and later releases:

- 1-Port 10-Gigabit Ethernet Shared Port Adapter, Version 2
- 5-Port Gigabit Ethernet Shared Port Adapter, Version 2



#### Note

---

The 1-Port 10-Gigabit Ethernet Shared Port Adapter is supported only on a PRE4 chassis.

---

For more configuration information on Gigabit Ethernet SPAs, see the chapter “Configuring Gigabit Ethernet SPAs” in the *Cisco uBR10012 Universal Broadband Router SIP and SPA Software Configuration Guide*.

## Supported MIBs

The following MIBs are supported in Cisco IOS Release 12.3(23)BC and later for the Cisco uBR10012 router and the Cisco Wideband SIP and Wideband SPA:

The following MIBS have been introduced in Cisco IOS Release 12.3(23)BC:

- DOCS-DSG-IF-MIB
- DTI-MIB

The following MIBS have been modified for Cisco IOS Release 12.3(23)BC:

- CISCO-CABLE-SPECTRUM-MIB
- CISCO-DOCS-EXT-MIB
- DOCS-IF-MIB
- DOCS-BPI-PLUS-MIB
- ENTITY-MIB
- IF-MIB

The following MIBS continue to be supported in Cisco IOS Release 12.3(23)BC:

- CISCO-CABLE-WIDEBAND-MIB
- CISCO-VENDORTYPE-OID-MIB

For information about MIBs associated with edge QAM devices or wideband cable modems, refer to the vendor documentation.

The following MIBs are supported by the Gigabit Ethernet SPAs on the Cisco uBR10012 router:

- ENTITY-MIB (RFC 2737)
- CISCO-ENTITY-ASSET-MIB
- CISCO-ENTITY-FRU-CONTROL-MIB
- CISCO-ENTITY-ALARM-MIB
- CISCO-ENTITY-EXT-MIB
- CISCO-ENTITY-SENSOR-MIB
- IF-MIB
- ETHERLIKE-MIB (RFC 2665)
- Remote Monitoring (RMON)-MIB (RFC 1757)
- CISCO-CLASS-BASED-QOS-MIB
- Ethernet MIB/RMON

The following MIBs are supported by the Cisco SIP-600 on the Cisco uBR10012 router:

- IF-MIB
- ENTITY-MIB

For more information on supported MIBs for the Cisco SIP-600 and Gigabit Ethernet SPAs, see the respective chapters “Overview of Cisco uBR10012 Router SIPs” and “Overview of Gigabit Ethernet SPAs” in the *Cisco uBR10012 Universal Broadband Router SIP and SPA Software Configuration Guide*.

For more information about MIB support on a Cisco uBR10012 router, refer to the *Cisco CMTS Universal Broadband Router MIB Specifications Guide*.

# Known Restrictions

## Cisco Wideband SPA Restrictions

The following restrictions apply to the *Cisco Wideband SPA* for Cisco IOS Release 12.3(23)BC:

- Voice call service flows are configurable only on wideband interfaces.
- Full DOCSIS QoS, including CIR support and downstream low latency service flows for voice, are configurable only on wideband interfaces.
- Dynamic services are configurable only on wideband interfaces.
- A wideband interface can only use RF channels from the same SPA.
- Scientific Atlanta DPC2505 and EPC2505 wideband cable modems support multicast traffic on the primary downstream channel only. These modems do not support multicast traffic on wideband downstream channels.

## Cisco SIP-600 Restrictions

The following restrictions apply to the Cisco SIP-600 for Cisco IOS Release 12.2(33)SCB.

- The Cisco Wideband SIP and the Cisco SIP-600 cannot co-exist on a Cisco uBR10012 router.
- The Cisco SIP-600 can be configured in slots 1 and 3 only, of the uBR10012 router.
- For a PRE4 setup, all SPAs share a 11.2Gbps ironbus connection.
- A PRE2 setup allows the typical ironbus connection in which bays 0 and 2 share a 2.8Gbps ironbus connection and bays 1 and 3 also share a 2.8Gbps ironbus connection.

For information on restrictions relevant to the Cisco SIP-600, see the section “Cisco SIP-600 Restrictions” and “WAN Slot Restrictions”, in the *Cisco uBR10012 Universal Broadband Router SIP and SPA Software Configuration Guide*.

## Gigabit Ethernet SPA Restrictions

The following restrictions apply to the *Gigabit Ethernet SPAs* for Cisco IOS Release 12.2(33)SCB:

- When used as an uplink interface, the Cisco 1-port 10-Gigabit Ethernet SPA supports from 1 to 10 VLANs with priority queues and class based weighted-fair queues, based on QoS configuration and test scenarios. When QoS is applied at multiple VLAN 10-Gigabit Ethernet interfaces other than the main 10-Gigabit Ethernet interface, unexpected drops with nonpriority class queues may occur.
- As an access interface, the Cisco 1-port 10-Gigabit Ethernet SPA does not support oversubscription at the VLAN level when using QoS Model F.
- You cannot configure more than two active ports for sending and receiving packets on the Cisco 5-Port Gigabit Ethernet SPA.
- The following features are not supported:
  - IEEE 802.1 Q-in-Q VLAN tag switching
  - Bridge protocol data units (BPDU) filtering