

Understanding and Troubleshooting Analog E & M Interface Types and Wiring Arrangements

Document ID: 8111

Introduction

Prerequisites

- Requirements

- Components Used

- Conventions

E & M Interface Supervision Signal Description

E & M Signaling Unit Side and Trunk Circuit Side Compatibility Issues

E & M Type I Interface Model

E & M Type II Interface Model

E & M Type III Interface Model

E & M Type V Interface Model

Troubleshoot E & M Interfaces at the Physical Level

- Hardware Troubleshooting Tools

- Precautions

- Troubleshoot Type 1 Interfaces

- Troubleshoot Type 2 Interfaces

- Troubleshoot Type 3 Interfaces

- Troubleshoot Type 5 Interfaces

Related Information

Introduction

This document discusses the standard analog E & M interface types I, II, III, V (IV is not supported by Cisco platforms) and wiring arrangements. You can use this document as a troubleshooting reference for wiring problems between the router and private branch exchange (PBX)/Telco equipment.

Refer to Analog E & M Signaling Overview for an overview of Analog E & M.

Refer to Understanding and Troubleshooting Analog E & M Start Dial Supervision Signaling for information on E & M Start Dial Supervision signaling (wink, delay, immediate).

Prerequisites

Requirements

This document is intended for personnel involved with Voice over IP networks with basic knowledge of voice networks.

Components Used

This document is not restricted to specific software and hardware versions.

Conventions

Refer to Cisco Technical Tips Conventions for more information on document conventions.

E & M Interface Supervision Signal Description

- **E** (Ear or Earth) Signal wire from trunking (CO) side to signaling side.
- **M** (Mouth or Magnet) Signal wire from signaling side to trunking (CO) side.
- **SG** (Signal Ground) Used on E & M Types II, III, IV (Type IV is not supported on Cisco router/gateways).
- **SB** (Signal Battery) Used on E & M Types II, III, IV (Type IV is not supported on Cisco router/gateways).
- **T/R** (Tip/Ring) T / R leads carry audio between the signaling unit and the trunking circuit. On a two-wire audio operation circuit, this pair carries the full-duplex audio path.
- **T1/R1** (Tip-1/Ring-1) Used on four-wire audio operation circuits only. The four-wire implementation provides separate paths to receive and send audio signals.

E & M Signaling Unit Side and Trunk Circuit Side Compatibility Issues

E & M signaling defines a trunk circuit side and a signaling unit side for each connection similar to the data circuit-terminating equipment (DCE) and data terminal equipment (DTE) reference type. Usually the PBX is the trunk circuit side and the Telco, CO, channel-bank, or Cisco voice enabled platform is the signaling unit side. The Cisco analog E & M interface functions as the signaling unit side and it expects the other side to be a trunk circuit. When you use E & M interface models Type II and Type V, you can connect two signaling unit sides back-to-back by appropriate crossing of the signaling leads. When you use E & M Type I and Type III interfaces, two signaling unit sides cannot be connected back-to-back.

Many PBX brands have E & M analog trunk cards that can operate as either the trunk circuit side or the signaling unit side. Since the Cisco E & M interfaces are fixed as the signaling unit side of the interface, it might be necessary to change the E & M trunk settings on the PBX to operate as the trunk circuit side. If you use Type I or III E & M, this is the only way the PBX works with the Cisco E & M interface.

Some PBX products (and many key systems) can only operate as the signaling unit side of the E & M interface. This means that they cannot interoperate with the Cisco E & M interface if Type I or Type III is chosen. If Type II or Type V E & M is used, PBX products fixed as "signaling unit" side can still be used with the Cisco E & M interface via Type II or Type V.

Each E & M signaling type has a unique circuit model and connection diagram. The figures in this document illustrate the different types.

E & M Type I Interface Model

E & M Type I is the original E & M lead signaling arrangement and it is the most common interface type in North America. This table displays the sent signal states for on/off hook signaling.

Type	PBX to Cisco Router/Gateway			Cisco Router/Gateway to PBX		
	Lead	On-Hook	Off-Hook	Lead	On-Hook	Off-Hook
1	M	Ground	Battery	E	Open	Ground

The router/gateway grounds its E-lead to signal a trunk seizure. The PBX applies the battery to its M-lead in order to signal a seizure. Cisco router/gateways expect to see off-hook conditions on the M-lead and signal off-hook to the remote device on E-lead.

E&M Type I Interface Model

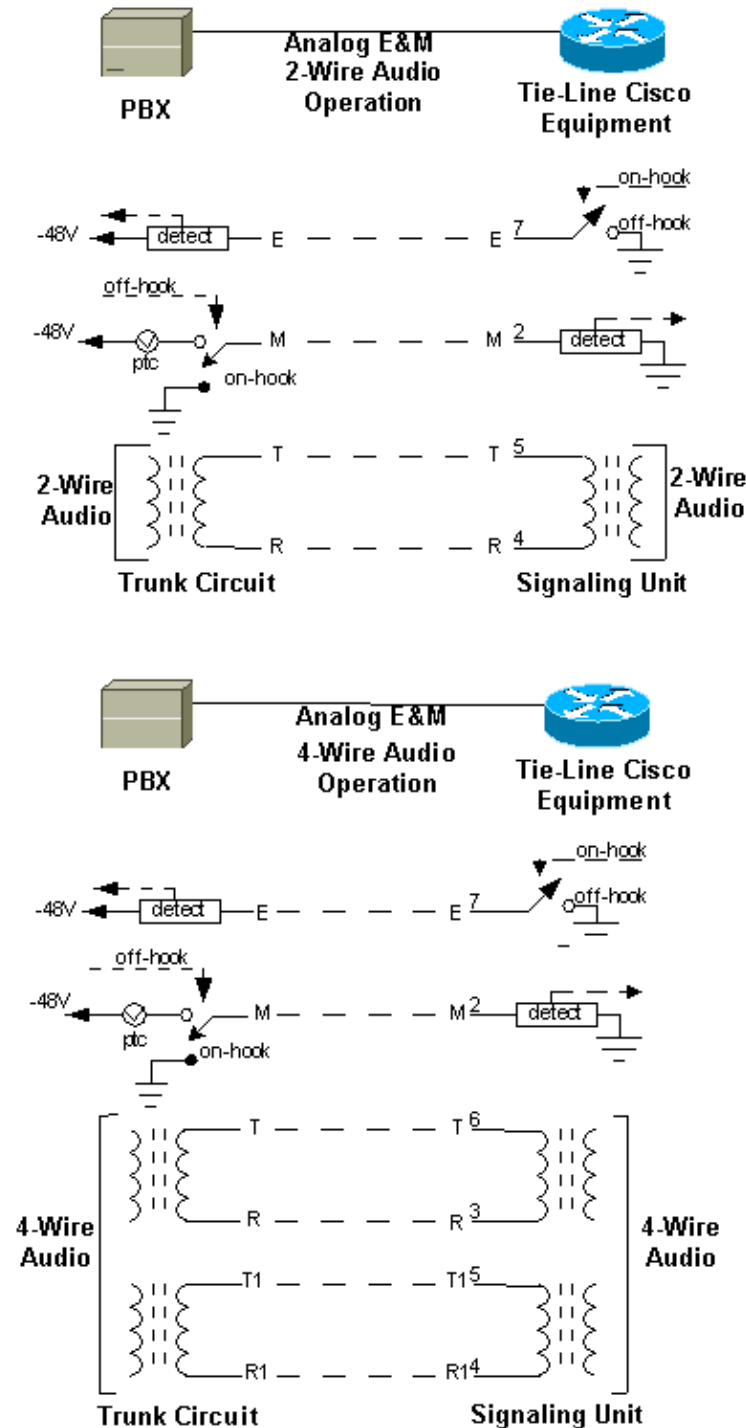

Note: For the four-wire audio setup, Pin 6 (Tip) and 3 (Ring) on the router transport the audio path from the PBX to the router. Pin 5 (Tip1) and 4 (Ring 1) on the router transport the audio path from the router to the PBX.

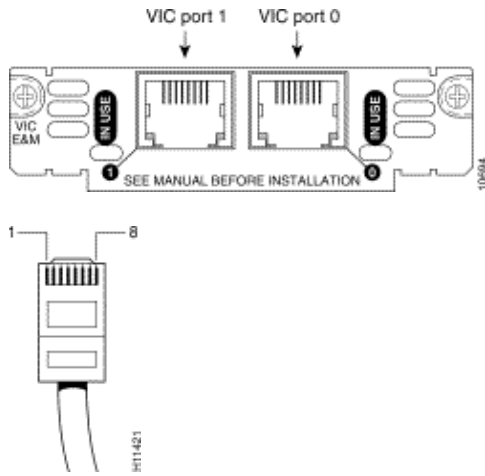

Things to consider with Type I interfaces include:

- Type I uses the E and M leads for supervisor signaling.
- Two signaling units cannot be connected back to back.
- Type I signaling unit and trunk circuit share a common ground.
- Type I does not provide isolation between trunk circuits and signaling units, can produce noise in audio circuits, or be susceptible to electrical transients.
- It is critical to provide and ground connection directly between the Cisco product and the PBX. Otherwise, there can be intermittent signaling operation for E & M.
- Four wires are used for Type I, two-wire audio operation.
- Six wires are used for Type I, four-wire audio operation.
- During inactivity, the E-lead is open and the M-lead is connected to the ground.
- The PBX (that acts as trunk circuit side) connects the M-lead to the battery in order to indicate the off-hook condition
- The Cisco router/gateway (signaling unit) connects the E-lead to the ground in order to indicate the off-hook condition

E & M Type II Interface Model

E & M Type II provides a four-wire fully-looped arrangement that provides full isolation between the trunks and signaling units. Type II is usually used on Centrex lines and Nortel PBX systems. This table displays the sent signal states for on/off hook signaling.

Type	PBX to Cisco Router/Gateway			Cisco Router/Gateway to PBX		
	Lead	On-Hook	Off-Hook	Lead	On-Hook	Off-Hook
2	M	Open	Battery	E	Open	Ground

The router/gateway grounds its E-lead to signal a trunk seizure. The PBX applies battery to its M-lead to signal a seizure. Cisco router/gateways expect to see off-hook conditions on the M-lead and signal off-hook to the remote device on E-lead.

E&M Type II Interface Model

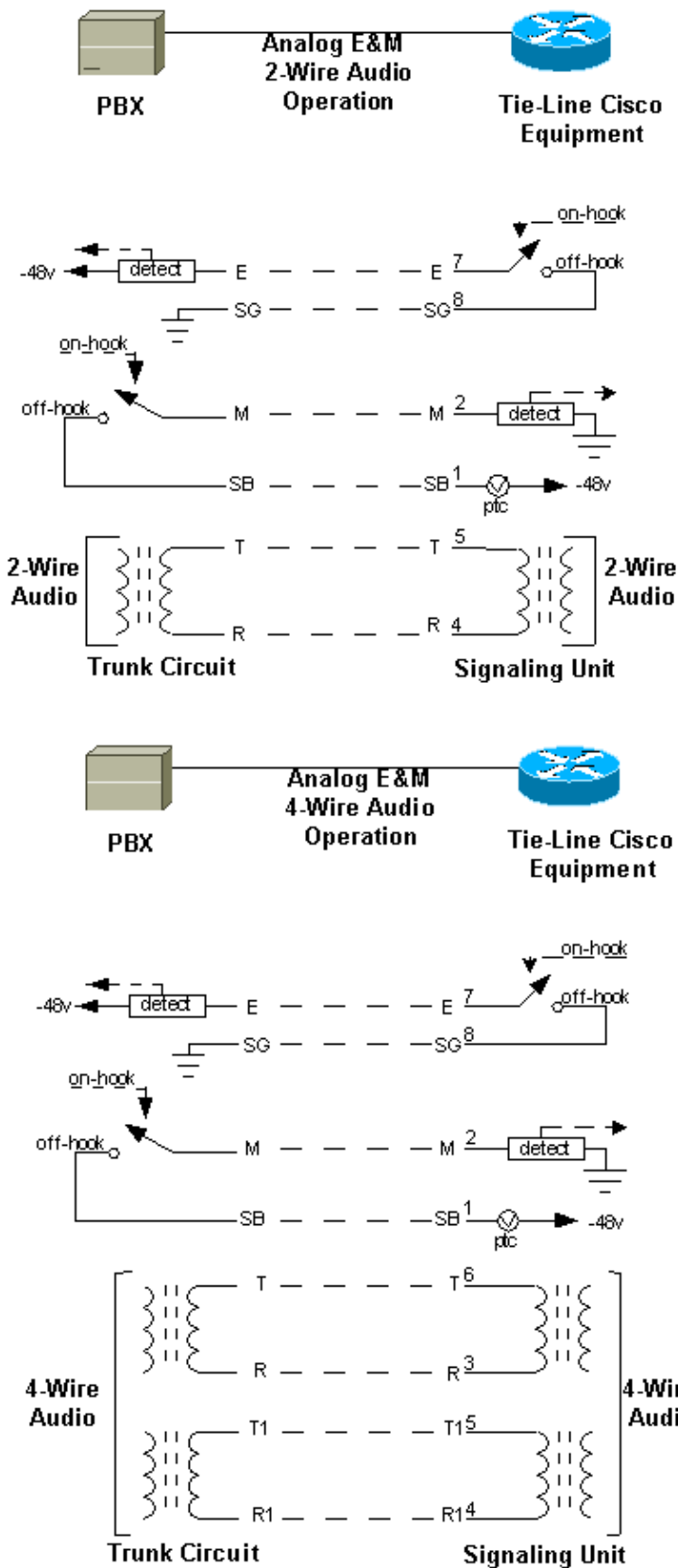

Note: For the four-wire audio setup, Pin 6 (Tip) and 3 (Ring) on the router transport the audio path from the PBX to the router. Pin 5 (Tip1) and 4 (Ring1) on the router transport the audio path from the router to the PBX.

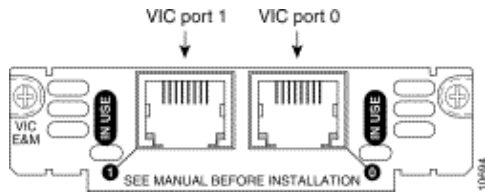

Things to consider with Type II interfaces include:

- Two signaling unit sides can be connected back-to-back if the appropriate signaling leads are swapped.
- Six wires are used for Type II, two-wire audio operation.
- Eight wires are used for Type II, four-wire audio operation.
- Type II uses four leads for supervision signaling: E, M, SB, and SG
- During inactivity both the E-lead and M-lead are open
- The PBX (that acts as trunk circuit side) connects the M-lead to the signal battery (SB) lead connected to the battery of the signaling side in order to indicate the off-hook condition.
- The Cisco router / gateway (signaling unit) connects the E-lead to the signal ground (SG) lead connected to the ground of the trunk circuit side in order to indicate the off-hook condition.

E & M Type III Interface Model

E & M Type III is a partially looped four-wire E & M arrangement with ground isolation. The signaling unit provides both the battery and the ground. This table displays the sent signal states for on/off hook signaling.

Type	PBX to Cisco Router/Gateway			Cisco Router/Gateway to PBX		
	Lead	On-Hook	Off-Hook	Lead	On-Hook	Off-Hook
3	M	Ground	Battery	E	Open	Ground

The router senses loop current on the M-lead for an inbound seizure and grounds its E-lead for an outbound seizure. Cisco router/gateways expect to see off-hook conditions on the M-lead and signal off-hook to the remote device on E-lead.

E&M Type III Interface Model

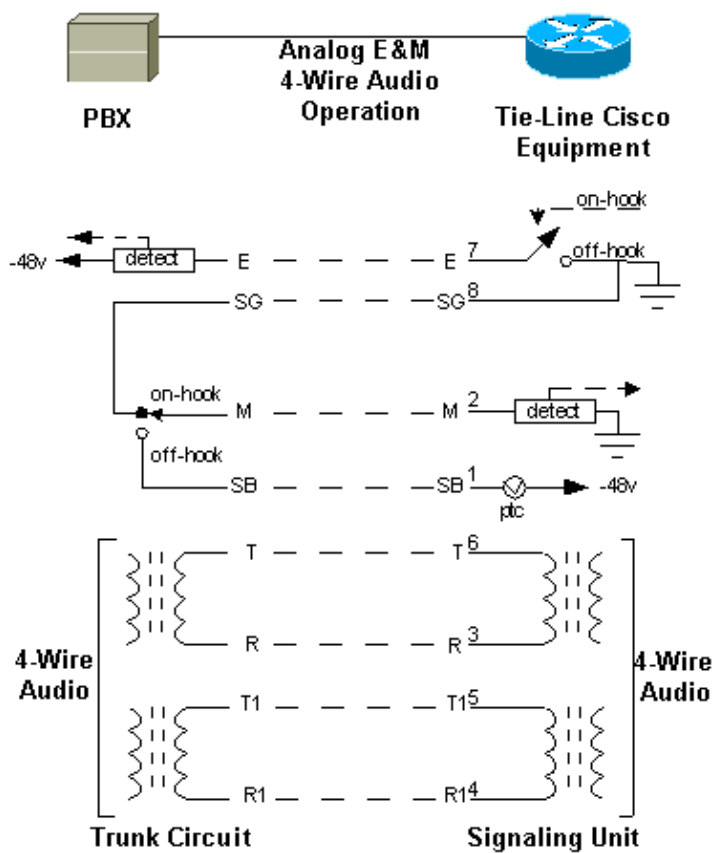
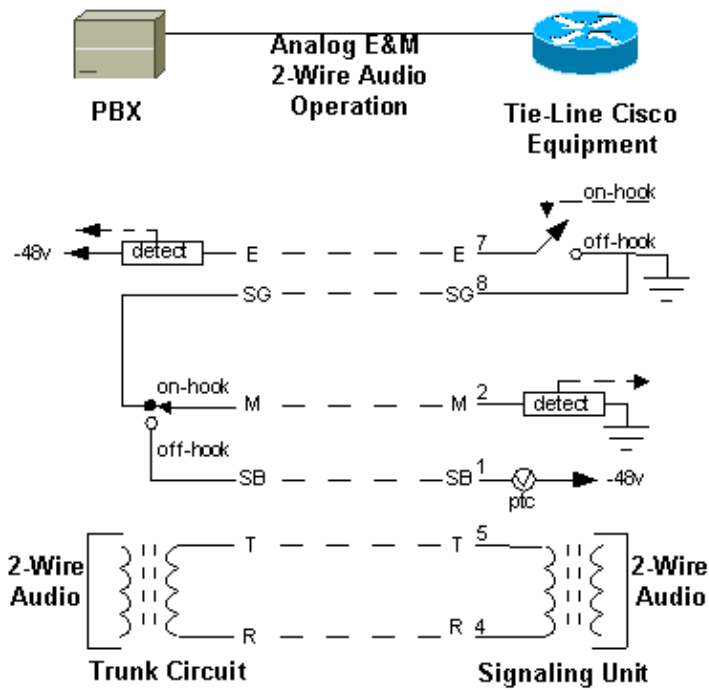

Note: For the four-wire audio setup, Pin 6 (Tip) and 3 (Ring) on the router transport the audio path from the PBX to the router. Pin 5 (Tip1) and 4 (Ring1) on the router transport the audio path from the router to the PBX.

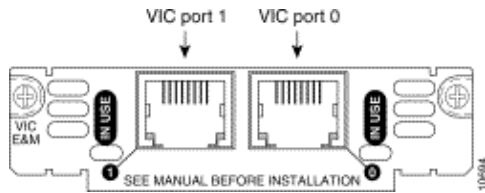

Things to consider with Type III interfaces include:

- Two signaling units cannot be connected back-to-back.
- Six wires are used for Type III, two-wire audio operation.
- Eight wires are used for Type III, four-wire audio operation.
- Type III uses four leads for supervision signaling: E, M, SB, and SG
- During inactivity, the E-lead is open and the M-lead is set to the ground connected to the SG lead of the signaling side.
- The PBX (that acts as trunk circuit side) disconnects the M-lead from the SG lead and connects it to the SB lead of the signaling side in order to indicate the off-hook condition.
- The Cisco router / gateway (signaling unit) connects the E-lead to the ground in order to indicate the off-hook condition

E & M Type V Interface Model

E & M Type V interface is widely used outside North America (nearly the world wide standard). Type V is a symmetrical two-wire lead arrangement that signals in both directions by means of open for on-hook and ground for off-hook.

This table displays the sent signal states for on/off hook signaling.

Type	PBX to Cisco Router/Gateway			Cisco Router/Gateway to PBX		
	Lead	On-Hook	Off-Hook	Lead	On-Hook	Off-Hook
5	M	Open	Ground	E	Open	Ground

The router/gateway grounds its E-lead to signal a trunk seizure. The PBX grounds its M-lead to signal a seizure. Cisco router/gateways expect to see off-hook conditions on the M-lead and signal off-hook to the remote device on E-lead.

E&M Type V Interface Model

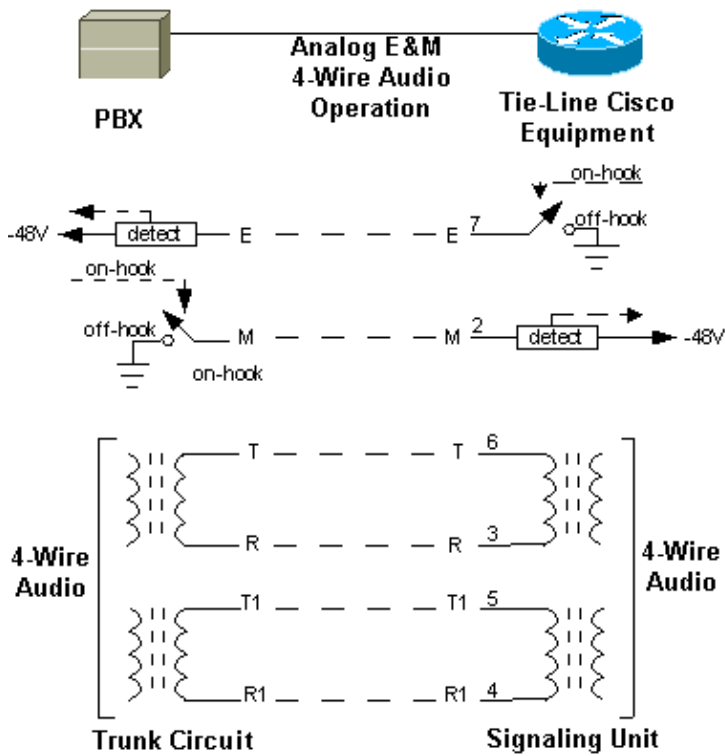
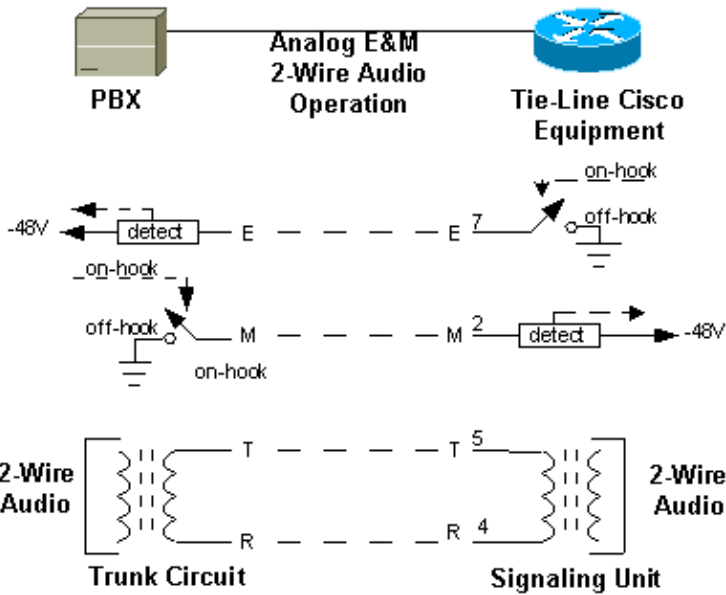

Note: For the four-wire audio setup, Pin 6 (Tip) and 3 (Ring) on the router transport the audio path from the PBX to the router. Pin 5 (Tip1) and 4 (Ring1) on the router transport the audio path from the router to the PBX.

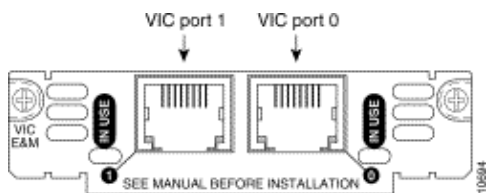

Things to consider with Type V interfaces include:

- Type V does not provide ground isolation.
- Two signaling unit sides can be connected back-to-back if the appropriate signaling leads are swapped.
- Four wires are used for Type V, two-wire audio operation.
- Six wires are used for Type V, four-wire audio operation.
- Type V uses two leads for supervisor signaling: E, and M
- During inactivity the E-lead and M-lead are open.
- The PBX (that acts as trunk circuit side) connects the M-lead to the ground in order to indicate the off-hook condition.
- The Cisco router / gateway (signaling unit) connects the E-lead to the ground in order to indicate off-hook condition.

Troubleshoot E & M Interfaces at the Physical Level

E & M provides the highest quality analog interface available, but it also is the most difficult to administer due to the number of leads, configurations, and protocol issues. Usually it is handy to have the appropriate reference diagram available when you verify the connections.

Hardware Troubleshooting Tools

Have these items available for an effective troubleshooting kit:

- Digital Volt Ohm Meter (VOM) with sharp-tipped probes. The ones with the "analog" bar graph and a beeper with pitch proportional to the display are particularly useful.
- Lineman's Buttset.
- RJ-45 breakout adapter. This has an RJ-45 socket on each end, with terminals for each of the lines distributed about each side.
- RJ-45 straight-through cable. (Verify that it is straight-through.)
- Alligator-clip patch-cables.

Precautions



Warning: While usually not hazardous, equipment closets where telecommunication devices exist can have some potentially harmful by-products. They include (but are not limited to):

- **Lead acid battery stacks** able to supply large amounts of current, and possibly flammable hydrogen fumes. Ventilation and insulation are the keys to avoiding damage. Wear long-sleeved shirts, pants, and steel-toed work boots. Keep electrically insulated work gloves and OSHA-approved eye protection handy. Avoid wearing metal objects such as chains, bracelets, rings, and watches unless under cover and away from making any connection. Voltage does not injure; current does.
- **Many wires** for voice, data, power, and so on. Watch for potentially damaging outages caused by pulling a wire that is snagged on another wire. RJ plugs have a tendency to snag on other wires and loosen equipment.
- **Sharp edges.** Equipment deployed before there were safety requirements regarding snag or cut hazards often have protruding bolts and screws. Full clothing protection helps protect you in these cases.
- **Loose, heavy equipment.** Objects in the equipment room may be less than secure. This equipment can fall and hurt the equipment, you, or others. If moving heavy objects is involved, it is a job best left to the facility staff of the client. Otherwise, use a back protector belt and follow proper OSHA-approved lifting and moving guidelines.

Troubleshoot Type 1 Interfaces

The four-wire Type 1 interface from the PBX (setup for Trunk Circuit side) has these characteristics:

- E detector "floats" at -48 V below ground.
- M contact has low ohms to ground on-hook, and is -48 v below ground when off-hook.
- Approximately 30 –150 ohms between T/R, sometimes in series with 2.2 uF of capacitance.
- Approximately 30 –150 ohms between T1/R1, sometimes in series with 2.2 uF of capacitance.

Confirm the Cable Interface from the PBX

Pull the suspect voice cable from the router and leave the other side connected to the PBX and perform these actions:

- With a VOM, measure DC voltage between pin 7 of the cable and the chassis ground. The meter should read between -24 v and -56 v. If not, pin 7 is likely not the E-lead on the PBX.
- Measure the other pins and look for -24 to -56 v to ground. Some devices, like an AT & T/Lucent PBX, bias the Tip/Ring leads to -48 v to aid debugging. On pins that had no conclusive energy, measure the ohms to ground with a VOM. If one shows less than 500 ohms, it is likely the M-lead. It should be pin 2 on the cable. If pin 2 shows between -24 v and -48 v to ground, it is possible that the PBX is off-hook; sometimes they busy-out what it figures is a "bad" port.
- With a VOM, measure the resistance (ohms) between Tip and Ring. It should read from 30 to 120 ohms if the PBX has no DC blocking capacitor. If there is a capacitor, you see the meter jump to around 100 ohms, then climb to infinity as the capacitor charges. With either signature, there is an audio pair. You just need to figure out which direction it is.
- Do the same for Tip-1/Ring-1. It should behave the same as Tip/Ring.
- Attach a buttset to Tip/Ring. While listening, ground E (pin 7 on the cable). If the PBX is configured to provide a dial tone, you should hear it in the buttset's earpiece. If you hear nothing, try the other audio pair in case it is cross-wired. If you still hear nothing, the PBX may not give a dial tone on a trunk line.
- It is acceptable to cross T with R or T1 with R1.

Additional Troubleshooting Tips

- Try another (known good) similar port on either the router or the PBX.
- Listen in on both sides of the audio path (one at a time) with the buttset to hear the call progress.
- Try to spoof the signaling of one end or the other by clipping one of the signals active to see if the equipment reacts as expected. Grounding E should fool the PBX into thinking there is an inbound call coming over the trunk, and it may respond with a dial tone (if provisioned to do so).
- Try to seize the trunk and see if the PBX applies battery to its M-lead to signal the seizure with the use of an extension off of the PBX.

Troubleshoot Type 2 Interfaces

The four-wire Type II interface from the PBX (setup for Trunk Circuit side) has these characteristics:

- E-lead detector "floats" at -48 v below ground.
- SG lead has a low ohms to ground.
- M-lead contact between M and SB is open when on-hook, and closed when off-hook.
- M-lead floats.
- SB-lead floats.
- Approximately 30 to 150 ohms between T/R, sometimes in series with 2.2 uF of capacitance.
- Approximately 30 to 150 ohms between T1/R1, sometimes in series with 2.2 uF of capacitance.

Confirm the Cable Interface from the PBX

Pull the suspect voice cable from the router and leave the other side connected to the PBX and then perform these actions:

- With a VOM, measure the DC voltage between E (pin 7 of the cable) and the chassis ground. The meter should read between -24 v and -56 v. If not, pin 7 on the cable is likely not the E-lead.
- Measure the other pins, looking for -24 to -56 v to ground. Some devices, like an AT&T/Lucent PBX, bias the Tip/Ring leads to -48 v to aid debugging. On pins that have no conclusive energy, measure the ohms to ground with a VOM. If one shows less than 500 ohms, it is likely the "SG" lead. It should be pin 8 on the cable.
- With a VOM, measure the resistance (ohms) between Tip and Ring. It should read from 30 to 120 ohms if the PBX has no DC blocking capacitor. If there is a capacitor, you see the meter jump to around 100 ohms, then climb to infinity as the capacitor charges. With either signature, there is an audio pair. You just need to figure out which direction it is.
- Do the same for Tip-1/Ring-1. It should behave the same as Tip/Ring.
- Attach a buttset to Tip/Ring. While listening, ground E (pin 7 on the cable). If the PBX is configured to provide a dial tone, you should hear it in the earpiece of the buttset. If you hear nothing, try the other audio pair in case it is cross-wired. If you still hear nothing, the PBX may not give a dial tone on a trunk line.
- It is acceptable to cross T with R or T1 with R1.
- In most cases, you can get M/SB backwards and E/SG backwards and things still work.

Additional Troubleshooting Tips

- Try another (known good) similar port on either the router or the PBX.
- Listen in on both sides of the audio path (one at a time) with the buttset to hear the call progress.
- Try to spoof the signaling of one end or the other by clipping one of the signals active to see if the equipment reacts as expected. Grounding E should fool the PBX into thinking there is an inbound call coming over the trunk, and it may respond with a dial tone (if provisioned to do so).
- Try to seize the trunk and see if M connects to ground with the use of an extension off of the PBX.

Troubleshoot Type 3 Interfaces

The four-wire Type III interface from the PBX has these characteristics:

- E-lead detector "floats" at -48 v below ground.
- M-lead contact between M and SG when on-hook, and between M and SB when off-hook.
- SG-lead floats.
- M-lead floats.
- SB-lead floats.
- Approximately 30 to 150 ohms between T/R, sometimes in series with 2.2 uF of capacitance.
- Approximately 30 to 150 ohms between T1/R1, sometimes in series with 2.2 uF of capacitance.

Confirm the Cable Interface from the PBX

Pull the suspect voice cable from the router and leave the other side connected to the PBX and then perform these actions:

- With a VOM, measure DC voltage between E (pin 7 of the cable) and the chassis ground. The meter should read somewhere between -24 v and -56 v. If not, pin 7 is likely not the E-lead.
- Measure the other pins and look for -24 to -56 v to ground. Some PBX bias (apply a DC voltage to control the operation of a device) the Tip/Ring leads to -48 v to aid debugging. On pins that have no conclusive energy:

- ◆ Look for a contact closure (low ohms) between M and SG (if the PBX is on-hook).
- ◆ Look for a contact closure (low ohms) between M and SB (if the PBX is off-hook).
- With a VOM, measure the resistance (ohms) between Tip and Ring. It should read from 30 to 120 ohms if the PBX has no DC blocking capacitor. If there is a capacitor, you see the meter jump to around 100 ohms, then climb to infinity as the capacitor charges. With either signature, there is an audio pair. You just need to figure out which direction it is.
- Do the same for Tip-1/Ring-1. It should behave the same as Tip/Ring.
- Attach a buttset to Tip/Ring. While listening, ground E (pin 7 on the cable). If the PBX is configured to provide a dial tone, you should hear it in the earpiece of the buttset. If you hear nothing, try the other audio pair in case it is cross-wired. If you still hear nothing, the PBX may not give a dial tone on a trunk line.
- It is acceptable to cross T with R or T1 with R1.

Additional Troubleshooting Tips

- Try another (known good) similar port on either the router or the PBX.
- Listen in on both sides of the audio path (one at a time) with the buttset to hear the call progress.
- Try to spoof the signaling of one end or the other by clipping one of the signals active to see if the equipment reacts as expected. Grounding E should fool the PBX into thinking there is an inbound call coming over the trunk, and it may respond with a dial tone (if provisioned to do so).
- Using an extension off of the PBX, try to seize the trunk and see if M (pin 2 on cable) connects to SB (pin 1 on the cable).

Troubleshoot Type 5 Interfaces

The four-wire Type V interface from the PBX has these characteristics:

- E-lead detector "floats" at -48 v below ground.
- M-lead contact ground is open when on-hook, and closed when off-hook.
- Approximately 30 to 150 ohms between T/R, sometimes in series with 2.2 uF of capacitance.
- Approximately 30 to 150 ohms between T1/R1, sometimes in series with 2.2 uF of capacitance.

Confirm the Cable Interface from the PBX

Pull the suspect voice cable from the router and leave the other side connected to the PBX and perform these actions:

- With a VOM, measure DC voltage between E (pin 7 of the cable) and the chassis ground. The meter should read between -24 v and -56 v. If not, pin 7 on the cable is likely not the E-lead.
- With a VOM, measure the resistance (ohms) between Tip and Ring. It should read from 30 to 120 ohms if the PBX has no DC blocking capacitor. If there is a capacitor, you see the meter jump to around 100 ohms, then climb to infinity as the capacitor charges. With either signature, there is an audio pair. You just need to figure out which direction it is.
- Do the same for Tip-1/Ring-1. It should behave the same as Tip/Ring.
- Attach a buttset to Tip/Ring. While listening, ground E (pin 7 on the cable). If the PBX is configured to provide a dial tone, you should hear it in the earpiece of the buttset. If you hear nothing, try the other audio pair in case it is cross-wired. If you still hear nothing, the PBX may not give a dial tone on a trunk line.
- It is acceptable to cross T with R or T1 with R1.

Additional Troubleshooting Tips

- Try another similar port on either the router or the PBX.
- Listen in on both sides of the audio path (one at a time) with the buttset to hear the call progress.

- Try to spoof the signaling of one end or the other by clipping one of the signals active to see if the equipment reacts as expected. Grounding E should fool the PBX into thinking there is an inbound call coming over the trunk, and it may respond with a dial tone (if provisioned to do so).
 - Using an extension off of the PBX, try to seize the trunk and see if M (pin 2 on the cable) connects to ground.
-

Related Information

- **Understanding E & M Voice Interface Cards**
 - **Analog E & M Signaling Overview**
 - **Understanding and Troubleshooting Analog E & M Start Dial Supervision Signaling**
 - **E & M Cable Pinouts Connecting Cisco 1750/2600/3600 E & M VIC to Lucent PBX G3R E & M Trunk**
 - **E & M Cable Pinouts to Connect Cisco 1750/2600/3600 E & M VIC to Nortel PBX Option 11 E & M Trunk**
 - **Analog Signaling (E & M, DID, FXS, FXO)**
 - **Configuring Voice Ports**
 - **Voice Technology Support**
 - **Voice and IP Communications Product Support**
 - **Recommended Reading: Troubleshooting Cisco IP Telephony**
 - **Technical Support & Documentation – Cisco Systems**
-

[Contacts & Feedback](#) | [Help](#) | [Site Map](#)

© 2008 – 2009 Cisco Systems, Inc. All rights reserved. [Terms & Conditions](#) | [Privacy Statement](#) | [Cookie Policy](#) | [Trademarks of Cisco Systems, Inc.](#)

Updated: Feb 02, 2006

Document ID: 8111
