

Table of Contents

<u>Configure EtherChannel Using an ML Card on ONS 15454 and Catalyst Switch Across RPR</u>	1
<u>Document ID: 69342</u>	1
<u>Introduction</u>	1
<u>Prerequisites</u>	1
<u>Requirements</u>	1
<u>Components Used</u>	1
<u>Conventions</u>	2
<u>Network Diagram</u>	2
<u>Configuration</u>	2
<u>Configuring RPR</u>	2
<u>Configuring EtherChannel</u>	4
<u>Verification</u>	5
<u>NetPro Discussion Forums – Featured Conversations</u>	9
<u>Related Information</u>	9

Configure EtherChannel Using an ML Card on ONS 15454 and Catalyst Switch Across RPR

Document ID: 69342

Introduction

Prerequisites

Requirements

Components Used

Conventions

Network Diagram

Configuration

Configuring RPR

Configuring EtherChannel

Verification

NetPro Discussion Forums – Featured Conversations

Related Information

Introduction

This document describes the procedure to configure EtherChannel and 802.1Q tunneling using a Cisco Catalyst 3500XL switch and the ML-Series card across the Resilient Packet Ring (RPR) in an Cisco ONS 15454 environment.

Prerequisites

Requirements

Cisco recommends that you have knowledge of these topics:

- Cisco ONS 15454
- Cisco ONS 15454 ML-Series Ethernet Cards
- Catalyst 3500XL switch

Components Used

The information in this document is based on these software and hardware versions:

- Cisco ONS 15454 Version 6.x
- Catalyst 3500XL switch that runs Cisco IOS® Software Release 12.0(5)XC
- ML (bundled as part of the ONS 15454 6.0 release) that runs Cisco IOS® Software Release 12.2(27)SV and later

The information in this document was created from the devices in a specific lab environment. All of the devices used in this document started with a cleared (default) configuration. If your network is live, make sure that you understand the potential impact of any command.

Conventions

Refer to Cisco Technical Tips Conventions for more information on document conventions.

Network Diagram

This document uses a lab setup with two ONS 15454 nodes and two Catalyst 3500 XL switches. Each ONS 15454 is equipped with one ML 1000–2 card, and a Resilient Packet Ring (RPR) is built between them across the ML 1000–2 card. Two Gigabit Ethernet ports on Catalyst 3500 XL are connected to two Gigabit Ethernet ports on the ML 1000–2 card respectively. The network diagram is displayed in Figure 1.

Figure 1: Network Diagram

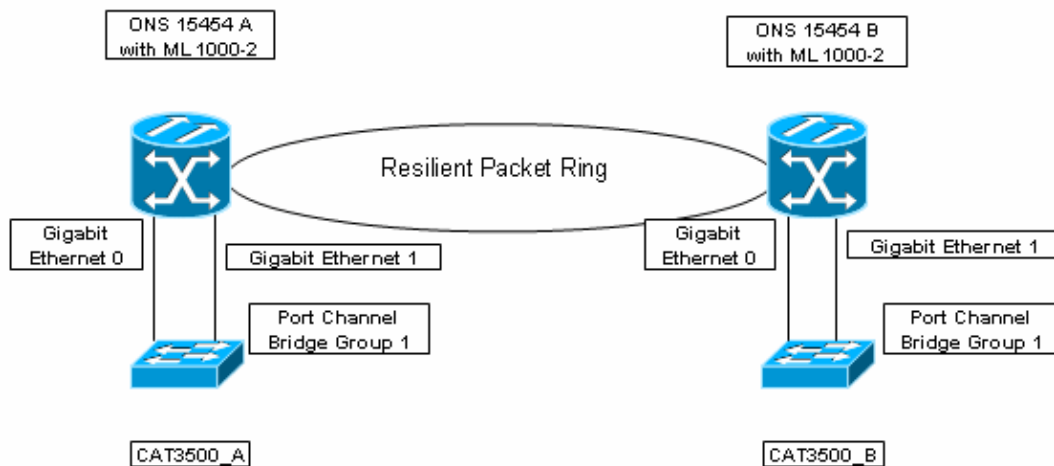

Configuration

Configuring RPR

Complete these steps to build RPR:

1. Create a circuit between POS 0 of ML1000–2 on ONS 15454 A and POS 1 of ML1000–2 on ONS 15454 B.
2. Create a circuit between POS 1 of ML1000–2 on ONS 15454 A and POS 0 of ML1000–2 on ONS 15454 B.
3. Configure ML1000–2 card on ONS 15454 A.
 - a. Turn on Integrated Bridging and Routing (IRB).

```
bridge irb
```

- b. Create bridge 1

```
Bridge 1 protocol rstp
```

- c. Configure the SRP interface.

```
interface SRP1  
no ip address  
no keepalive
```

```

spr station-id 3
spr topology discovery
hold-queue 150 in
!
interface SPR1.1
encapsulation dot1Q 1 native
no snmp trap link-status
bridge-group 1
bridge-group 1 spanning-disabled
!

```

d. Configure interface POS0.

```

!
interface POS0
no ip address
load-interval 30
spr interface-id 1
spr keepalive
crc 32
!

```

e. Configure interface POS1.

```

!
interface POS1
no ip address
load-interval 30
spr interface-id 1
spr keepalive
crc 32
!

```

4. Configure ML1000-2 card on ONS 15454 B.

a. Turn on Integrated Bridging and Routing (IRB).

```

bridge irb

```

b. Create bridge 1

```

Bridge 1 protocol rstp

```

c. Configure the SRP interface.

```

interface SPR1
no ip address
no keepalive
spr station-id 4
spr topology discovery
hold-queue 150 in
!
interface SPR1.1
encapsulation dot1Q 1 native
no snmp trap link-status
bridge-group 1
bridge-group 1 spanning-disabled
!

```

d. Configure interface POS0.

```

!
interface POS0
no ip address
load-interval 30
spr interface-id 1
spr keepalive

```

```

        crc 32
    !
e. Configure interface POS1.

    !
    interface POS1
    no ip address
    load-interval 30
    spr interface-id 1
    spr keepalive
    crc 32
    !

```

Configuring EtherChannel

Complete these steps to build EtherChannel:

1. Configure interface GigabitEthernet0/1 and GigabitEthernet0/2 on CAT3500_A.

```

!
interface GigabitEthernet0/1
port group 1 distribution destination
switchport trunk encapsulation dot1q
switchport mode trunk
!
interface GigabitEthernet0/2
port group 1 distribution destination
switchport trunk encapsulation dot1q
switchport mode trunk
!

```

2. Configure interface GigabitEthernet0/1 and GigabitEthernet0/2 on CAT3500_B.

```

!
interface GigabitEthernet0/1
port group 1 distribution destination
switchport trunk encapsulation dot1q
switchport mode trunk
!
interface GigabitEthernet0/2
port group 1 distribution destination
switchport trunk encapsulation dot1q
switchport mode trunk
!

```

3. Configure ML1000-2 on ONS 15454 A.

- a. Configure interface GigabitEthernet 0 and GigabitEthernet 1.

```

!
interface GigabitEthernet0
no ip address
channel-group 1
mode dot1q-tunnel
l2protocol-tunnel cdp
l2protocol-tunnel stp
l2protocol-tunnel vtp
no cdp enable
!
interface GigabitEthernet1
no ip address
channel-group 1
mode dot1q-tunnel

```

```
l2protocol-tunnel cdp
l2protocol-tunnel stp
l2protocol-tunnel vtp
no cdp enable
!
```

b. Configure Port-Channel.

```
!
interface Port-channel1
no ip address
hold-queue 225 in
!
interface Port-channel1.1
encapsulation dot1Q 1 native
no snmp trap link-status
bridge-group 1
bridge-group 1 spanning-disabled
!
```

4. Configure ML1000-2 on ONS 15454 B.

a. Configure interface GigabitEthernet0 and GigabitEthernet 1.

```
!
interface GigabitEthernet0
no ip address
channel-group 1
mode dot1q-tunnel
l2protocol-tunnel cdp
l2protocol-tunnel stp
l2protocol-tunnel vtp
no cdp enable
!
interface GigabitEthernet1
no ip address
channel-group 1
mode dot1q-tunnel
l2protocol-tunnel cdp
l2protocol-tunnel stp
l2protocol-tunnel vtp
no cdp enable
!
```

b. Configure Port-Channel.

```
!
interface Port-channel1
no ip address
hold-queue 225 in
!
interface Port-channel1.1
encapsulation dot1Q 1 native
no snmp trap link-status
bridge-group 1
bridge-group 1 spanning-disabled
!
```

Verification

Complete these steps to verify the configuration:

1. Issue the **show interfaces port-channel** command from the ML1000-2 on ONS 15454 A. This

command showsthat the EtherChannel contains two Gigabit Ethernet ports (see the boldface characters).

```
15454A_ML1000-2>show interface port-channel 1

Port-channell1 is up, line protocol is up

Hardware is GEChannel, address is 000d.28bd.0b34 (bia 0000.0000.0000)

MTU 1500 bytes, BW 2000000 Kbit, DLY 10 usec,
    reliability 255/255, txload 1/255, rxload 1/255

Encapsulation: ARPA, loopback not set

Keepalive set (10 sec)

ARP type: ARPA, ARP Timeout 04:00:00

    No. of active members in this channel: 2

        Member 0 : GigabitEthernet0 , Full-duplex, 1000Mb/s

        Member 1 : GigabitEthernet1 , Full-duplex, 1000Mb/s

Last input 00:00:00, output 00:00:00, output hang never

Last clearing of "show interface" counters never

Input queue: 0/150/0/0 (size/max/drops/flushes); Total output drops: 0

Queueing strategy: fifo

Output queue: 0/80 (size/max)

5 minute input rate 4000 bits/sec, 7 packets/sec

5 minute output rate 2000 bits/sec, 4 packets/sec

495875 packets input, 33757916 bytes

Received 493640 broadcasts (0 IP multicast)

0 runts, 0 giants, 0 throttles

0 input errors, 0 CRC, 0 frame, 0 overrun, 0 ignored

0 watchdog, 0 multicast

0 input packets with dribble condition detected

55924 packets output, 4080533 bytes, 0 underruns

0 output errors, 0 collisions, 0 interface resets

0 babbles, 0 late collision, 0 deferred

0 lost carrier, 0 no carrier

0 output buffer failures, 0 output buffers swapped out
```

2. Issue the **show interfaces port-channel** command from the ML1000-2 on ONS 15454 B. This command shows that the EtherChannel contains two Gigabit Ethernet ports (see the boldface characters).

```

15454B_ML1000-2>show int port-channel 1

Port-channel1 is up, line protocol is up

Hardware is GEChannel, address is 0013.60f8.65f4 (bia 0000.0000.0000)

MTU 1500 bytes, BW 2000000 Kbit, DLY 10 usec,
    reliability 255/255, txload 1/255, rxload 1/255

Encapsulation: ARPA, loopback not set

Keepalive set (10 sec)

ARP type: ARPA, ARP Timeout 04:00:00

    No. of active members in this channel: 2

        Member 0 : GigabitEthernet0 , Full-duplex, 1000Mb/s
        Member 1 : GigabitEthernet1 , Full-duplex, 1000Mb/s

Last input 00:00:00, output 00:00:00, output hang never

Last clearing of "show interface" counters never

Input queue: 0/150/0/0 (size/max/drops/flushes); Total output drops: 0

Queueing strategy: fifo

Output queue: 0/80 (size/max)

5 minute input rate 3000 bits/sec, 5 packets/sec

5 minute output rate 3000 bits/sec, 6 packets/sec

    1970114 packets input, 143644364 bytes

    Received 1969971 broadcasts (0 IP multicast)

    0 runts, 0 giants, 0 throttles

    0 input errors, 0 CRC, 0 frame, 0 overrun, 0 ignored

    0 watchdog, 0 multicast

    0 input packets with dribble condition detected

2256335 packets output, 164715496 bytes, 0 underruns

    0 output errors, 0 collisions, 0 interface resets

    0 babbles, 0 late collision, 0 deferred

    0 lost carrier, 0 no carrier

    0 output buffer failures, 0 output buffers swapped out

```

3. Issue the **show cdp neighbor** command on the CAT3500_A (see Figure 2). This command displays CAT3500_B as its neighbor through the EtherChannel.

Figure 2: show cdp neighbor on CAT3500_A

```
CAT3500_A#show cdp neighbor
Capability Codes: R - Router, T - Trans Bridge, B - Source Route Bridge
                  S - Switch, H - Host, I - IGMP, r - Repeater

Device ID          Local Intrfce    Holdtme    Capability    Platform  Port ID
CAT3500_B          Gig 0/1          170        T S           WS-C3524-PGig 0/2
CAT3500_B          Gig 0/1          170        T S           WS-C3524-PGig 0/1
CAT3500_A#
```

4. Issue the **show cdp neighbor** command on the CAT3500_B (see Figure 3). This command displays CAT3500_A as its neighbor through the EtherChannel.

Figure 3: show cdp neighbor on CAT3500_B

```
CAT3500_B#show cdp neighbor
Capability Codes: R - Router, T - Trans Bridge, B - Source Route Bridge
                  S - Switch, H - Host, I - IGMP, r - Repeater

Device ID          Local Intrfce    Holdtme    Capability    Platform  Port ID
CAT3500_A          Gig 0/1          177        T S           WS-C3524-XGig 0/2
CAT3500_A          Gig 0/1          177        T S           WS-C3524-XGig 0/1
CAT3500_B#
```

5. Perform a ping test.

a. Configure VLAN2 on CAT3500_A with an IP Address 192.168.0.2.

```
!
interface VLAN2
 ip address 192.168.0.2 255.255.255.0
 no ip directed-broadcast
 no ip route-cache
!
```

b. Configure VLAN2 on CAT3500_B with an IP Address 192.168.0.4.

```
!
interface VLAN2
 ip address 192.168.0.4 255.255.255.0
 no ip directed-broadcast
 no ip route-cache
!
```

c. Issue the **ping** command on CAT3500_A (see Figure 4).

```
ping 192.168.0.4
```

Figure 4: PING Test from CAT3500_A to CAT3500_B

```
CAT3500A#ping 192.168.0.4
Type escape sequence to abort.
Sending 5, 100-byte ICMP Echos to 192.168.0.4, timeout is 2 seconds:
!!!!
Success rate is 100 percent (5/5), round-trip min/avg/max = 2/2/3 ms
CAT3500A#
```

d. Issue the **ping** command on CAT3500_B (see Figure 5).

```
ping 192.168.0.2
```

Figure 5: PING Test from CAT3500_B to CAT3500_A

```
CAT3500B#ping 192.168.0.2
Type escape sequence to abort.
Sending 5, 100-byte ICMP Echos to 192.168.0.2, timeout is 2 seconds:
!!!!
Success rate is 100 percent (5/5), round-trip min/avg/max = 2/9/31 ms
CAT3500B#
```

NetPro Discussion Forums – Featured Conversations

Networking Professionals Connection is a forum for networking professionals to share questions, suggestions, and information about networking solutions, products, and technologies. The featured links are some of the most recent conversations available in this technology.

NetPro Discussion Forums – Featured Conversations for Optical
Service Providers: Optical Networking
Service Providers: Metro

Related Information

- **Build a Resilient Packet Ring with Four Nodes Through ML Card on Cisco ONS 15454**
- **Optical Networking Support Resources**
- **Technical Support & Documentation – Cisco Systems**

All contents are Copyright © 1992–2006 Cisco Systems, Inc. All rights reserved. Important Notices and Privacy Statement.

Updated: Apr 10, 2006

Document ID: 69342
