

# Add One More Node to the Resilient Packet Ring

Document ID: 61921

---

## Introduction

### Prerequisites

- Requirements
- Components Used
- Conventions

### Topology

### Add One More Node

### Final Configuration

- ML 1
- ML 2
- ML 3

### Related Information

---

## Introduction

This document describes the procedure to add one or more nodes to the Resilient Packet Ring (RPR) on ML cards for Cisco ONS 15454.

## Prerequisites

### Requirements

Cisco recommends that you have knowledge of these topics:

- Cisco ONS 15454
- Cisco ONS 15454 ML-Series Ethernet Cards
- Cisco IOS® Software
- Bridging and IP Routing

### Components Used

The information in this document is based on these software and hardware versions:

- Cisco ONS 15454 that runs ONS Release 4.1.3.
- ML (bundled as part of the ONS 4.1.3 release) that runs Cisco IOS Software Release 12.1(19) EO1.

**Note:** The configurations in this document are based on a Bridging over RPR solution.

The information in this document was created from the devices in a specific lab environment. All of the devices used in this document started with a cleared (default) configuration. If your network is live, make sure that you understand the potential impact of any command.

### Conventions

Refer to Cisco Technical Tips Conventions for more information on document conventions.

# Topology

Resilient Packet Ring (RPR) is a standard-based layer 2 architecture, optimized for bursty data traffic. The RPR enables ring-based architecture without the need for Ethernet Spanning Tree or the SONET/SDH protection scheme, and still provides sub-50 ms ring convergence time for Ethernet and IP services. RPR provides SONET type of protection without the need to reserve the bandwidth. RPR can work with or without SONET protection. RPR on ML cards introduces another point between the Packet Over SONET (POS) interfaces and Ethernet interfaces. A Shared Packet Ring (SPR) interface is a virtual interface that provides this link. For RPR, both POS ports act as members of the SPR interface. The SPR interface automatically performs protection wrapping.

Figure 1 indicates two circuits between POS ports on ONS 15454 nodes over SONET. A single SPR1 interface on each ML card handles the RPR function.

**Figure 1 Two Node Resilient Packet Ring**

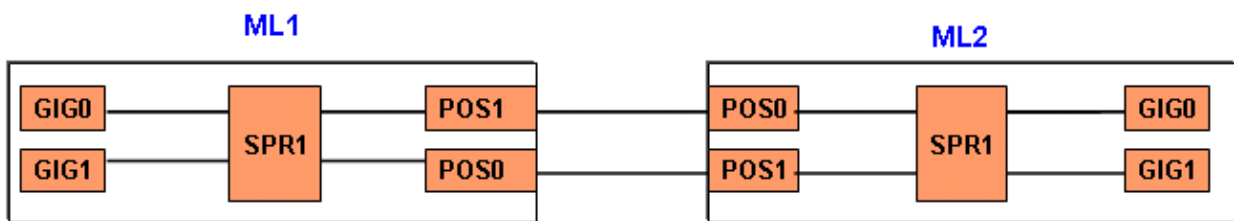

With the addition of a third node, there are three circuits among POS ports on 15454 nodes over SONET (see Figure 2).

**Figure 2 Three Node Resilient Packet Ring**

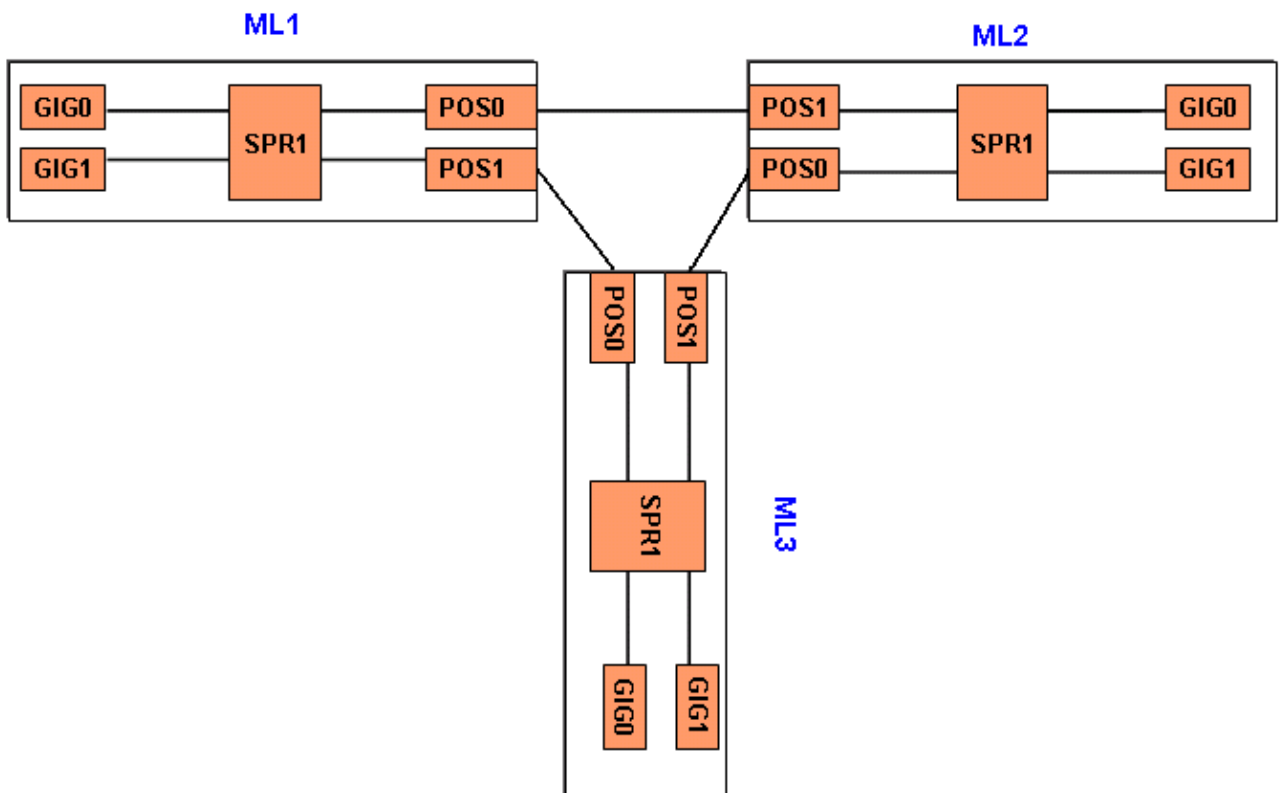

# Add One More Node

Complete these steps in order to add one more node to the RPR:

1. Shut down the POS port on ML1 that faces the span where you want to add the new node. The port is **POS 1** here:

```
ML1#configuration terminal
Enter configuration commands, one per line. End with CNTL/Z.
ML1(config)#interface POS 1
ML1(config-if)#shutdown
ML1(config-if)#^Z
```

2. Shut down the POS port on ML2 that faces the span where you want to add the new node. The port is **POS 0** in this case:

```
ML2#configuration terminal
Enter configuration commands, one per line. End with CNTL/Z.
ML2(config)#interface POS 0
ML2(config-if)#shutdown
ML2(config-if)#^Z
```

3. Delete the Synchronous Transport Signal (STS) path between the adjacent nodes for RPR (see Figure 3).

**Figure 3 Delete the STS Path**

Circuit Name	Type	Size	Protection	Dir	Status	Source	Destination	# of VLANs	# of Spans
ML1_to_ML2	STS	STS-12c	None	2-way	ACTIVE	Hilton190/s14/p0	Hilton190/s15/p1		0
ML2_to_ML1	STS	STS-12c	None	2-way	ACTIVE	Hilton190/s15/p0	Hilton190/s14/p1		0

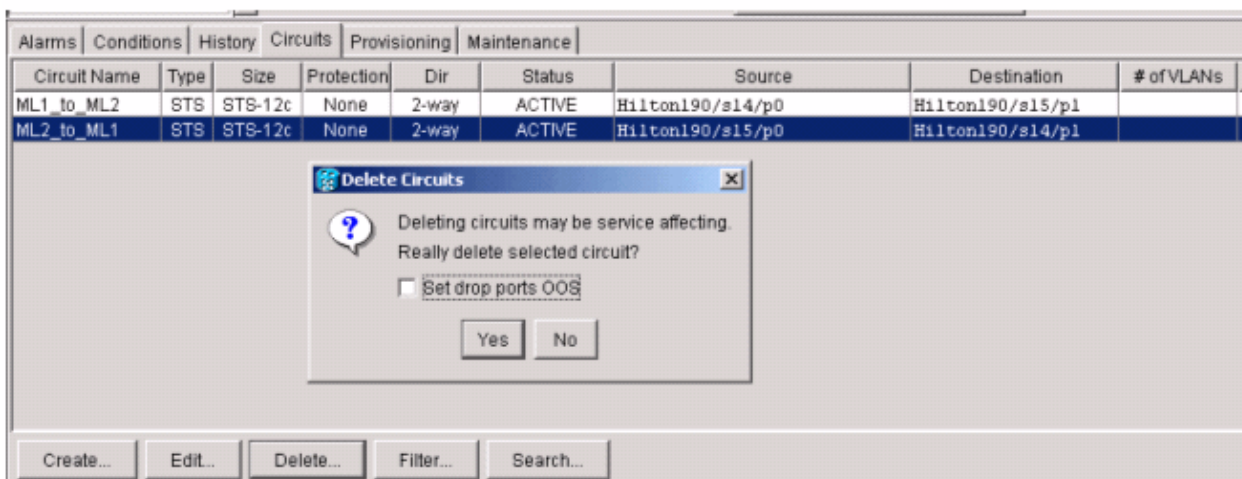

4. Verify whether Ethernet connectivity still exists on RPR (with test set, and routing tables of the customer).
5. Add the new node (assume that the node is already provisioned for target identifier (TID), IP address, SONET ports IS, SONET Data Communications Channel (SDCC) enabled, and so on).
6. Upload the ML configuration to the new node (ML 3). See the ML 3 configuration in the Final Configuration section.
7. Build two new circuits (and ensure that you select IS as the circuit state) from POS 0 of ML2 to POS 1 of ML3, and from POS 0 of ML3 to POS 1 of ML1 (see Figure 4). Check the audit log to see if the circuit goes in ADMIN\_IS or ADMIN\_OOS.

**Figure 4 Add Two New Circuits**

Alarms	Conditions	History	Circuits	Provisioning	Maintenance				
Circuit Name	Type	Size	Protection	Dir	Status	Source	Destination	# of VLANs	# of Spans
ML1_to_ML2	STS	STS-12c	None	2-way	ACTIVE	Hilton190/s14/p0	Hilton190/s15/p1		0
ML2_to_ML3	STS	STS-12c	Unprot	2-way	ACTIVE	Hilton190/s15/p0	Hilton193/s14/p1		1
ML3_to_ML1	STS	STS-12c	Unprot	2-way	ACTIVE	Hilton193/s14/p0	Hilton190/s14/p1		1

8. Perform **no shutdown** on POS 1 port in ML 1 that faces the new node:

```
ML1#configuration terminal
Enter configuration commands, one per line. End with CNTL/Z.
ML1(config)#interface POS 1
ML1(config-if)#no shutdown
ML1(config-if)#^Z
```

9. Perform **no shutdown** on POS 0 port in ML 2 that faces the new node:

```
ML2#configuration terminal
Enter configuration commands, one per line. End with CNTL/Z.
ML2(config)#interface POS 0
ML2(config-if)#no shutdown
ML2(config-if)#^Z
```

10. Verify whether Ethernet connectivity still exists on RPR (with test set and routing tables of the customer)
11. Monitor Ethernet traffic for at least one hour after node insertion.

## Final Configuration

This section provides the final configuration for ML 1, ML 2, and ML3.

### ML 1

```
ML1#show run
Building configuration...

Current configuration : 1238 bytes
!
version 12.1
no service pad
service timestamps debug uptime
service timestamps log uptime
no service password-encryption
!
hostname ML1
!
enable password cisco
!
ip subnet-zero
!
!
bridge irb
!
!
interface SPR1
 no ip address
 no keepalive
 spr station-id 1
 bridge-group 1
 bridge-group 1 spanning-disabled
 hold-queue 150 in
!
interface FastEthernet0
 no ip address
```

```
bridge-group 1
bridge-group 1 spanning-disabled
!
interface FastEthernet1
no ip address
shutdown
!
interface FastEthernet2
no ip address
shutdown
!
interface FastEthernet3
no ip address
shutdown
!
interface FastEthernet4
no ip address
shutdown
!
interface FastEthernet5
no ip address
shutdown
!
interface FastEthernet6
no ip address
shutdown
!
interface FastEthernet7
no ip address
shutdown
!
interface FastEthernet8
no ip address
shutdown
!
interface FastEthernet9
no ip address
shutdown
!
interface FastEthernet10
no ip address
shutdown
!
interface FastEthernet11
no ip address
shutdown
!
interface POS0
no ip address
spr-intf-id 1
crc 32
!
interface POS1
no ip address
spr-intf-id 1
crc 32
!
ip classless
no ip http server
!
!
!
!
line con 0
exec-timeout 5 5
password ww
```

```
line vty 0 4
  exec-timeout 50 0
  password ww
  login
!
end
```

## ML 2

```
ML2#show run
Building configuration...

Current configuration : 1238 bytes
!
version 12.1
no service pad
service timestamps debug uptime
service timestamps log uptime
no service password-encryption
!
hostname ML2
!
enable password CISCO15
!
ip subnet-zero
!
!
bridge irb
!
!
interface SPR1
  no ip address
  no keepalive
  spr station-id 2
  bridge-group 1
  bridge-group 1 spanning-disabled
  hold-queue 150 in
!
interface FastEthernet0
  no ip address
  bridge-group 1
  bridge-group 1 spanning-disabled
!
interface FastEthernet1
  no ip address
  shutdown
!
interface FastEthernet2
  no ip address
  shutdown
!
interface FastEthernet3
  no ip address
  shutdown
!
interface FastEthernet4
  no ip address
  shutdown
!
interface FastEthernet5
  no ip address
  shutdown
!
interface FastEthernet6
```

```

no ip address
shutdown
!
interface FastEthernet7
no ip address
shutdown
!
interface FastEthernet8
no ip address
shutdown
!
interface FastEthernet9
no ip address
shutdown
!
interface FastEthernet10
no ip address
shutdown
!
interface FastEthernet11
no ip address
shutdown
!
interface POS0
no ip address
spr-intf-id 1
crc 32
!
interface POS1
no ip address
spr-intf-id 1
crc 32
!
ip classless
no ip http server
!
!
!
!
line con 0
exec-timeout 5 5
password cisco
line vty 0 4
exec-timeout 50 0
password cisco
login
!
end

```

## ML 3

```

ML3#show run
Building configuration...

Current configuration : 1238 bytes
!
version 12.1
no service pad
service timestamps debug uptime
service timestamps log uptime
no service password-encryption
!
hostname ML3
!
enable password cisco

```

```
!  
ip subnet-zero  
!  
!  
bridge irb  
!  
!  
interface SPR1  
  no ip address  
  no keepalive  
  spr station-id 3  
  bridge-group 1  
  bridge-group 1 spanning-disabled  
  hold-queue 150 in  
!  
interface FastEthernet0  
  no ip address  
  bridge-group 1  
  bridge-group 1 spanning-disabled  
!  
interface FastEthernet1  
  no ip address  
  shutdown  
!  
interface FastEthernet2  
  no ip address  
  shutdown  
!  
interface FastEthernet3  
  no ip address  
  shutdown  
!  
interface FastEthernet4  
  no ip address  
  shutdown  
!  
interface FastEthernet5  
  no ip address  
  shutdown  
!  
interface FastEthernet6  
  no ip address  
  shutdown  
!  
interface FastEthernet7  
  no ip address  
  shutdown  
!  
interface FastEthernet8  
  no ip address  
  shutdown  
!  
interface FastEthernet9  
  no ip address  
  shutdown  
!  
interface FastEthernet10  
  no ip address  
  shutdown  
!  
interface FastEthernet11  
  no ip address  
  shutdown  
!  
interface POS0  
  no ip address
```

```
spr-intf-id 1
crc 32
!
interface POS1
no ip address
spr-intf-id 1
crc 32
!
ip classless
no ip http server
!
!
!
!
line con 0
exec-timeout 5 5
password cisco
line vty 0 4
exec-timeout 50 0
password cisco
login
!
end
```

---

## Related Information

- [Configuring Resilient Packet Ring](#)
- [Technical Support & Documentation – Cisco Systems](#)

---

[Contacts & Feedback](#) | [Help](#) | [Site Map](#)

© 2009 – 2010 Cisco Systems, Inc. All rights reserved. [Terms & Conditions](#) | [Privacy Statement](#) | [Cookie Policy](#) | [Trademarks of Cisco Systems, Inc.](#)

---

Updated: Dec 01, 2005

Document ID: 61921

---