

Cisco PGW 2200 and HSI Softswitch Out-of-band DTMF for SIP and H.323

Document ID: 49923

Introduction

Prerequisites

Requirements

Components Used

Conventions

Cisco PGW 2200 and HSI – DTMF Out-of-band

H.323

SIP

NetPro Discussion Forums – Featured Conversations

Related Information

Introduction

This document describes the working of out-of-band dual-tone multifrequency (DTMF) on the Cisco PGW 2200 for Call Control mode by using either a Session Initiation Protocol (SIP) Proxy Server, a Cisco H.323 Signaling Interface (HSI) adjunct platform, or both for H.323 communication. For SIP the **sip-notify** is a new DTMF relay method that is proposed on Cisco IOS® Software and on the Cisco PGW 2200. For the Cisco HSI transmit and receive of H.245 Alphanumeric information during the H.245 negotiation phase is implemented.

Prerequisites

Requirements

Readers of this document should have knowledge of these topics:

- Cisco Media Gateway Controller – Software Release 9
- Support of SIP SUBSCRIBE/NOTIFY Methods
- SIP Support for telephony event subscription and for sending telephone event notification will be implemented for the following methods:
 - ◆ SUBSCRIBE Method for subscription Complying with RFC 3265
 - ◆ NOTIFY Method for notification Complying with RFC 3265 and draft-Mahy-sip-signaled-digits-00.txt
- DTMF Digits – 0–9, *, # and ABCD – ITU–T Q.23 and Q.24 which explain "dynamic range" and "tone duration." No DTMF tone duration should less than 40 ms.
- Configuring SIP DTMF Support
- ITU Recommendation H.245 version 7, June 2000

Components Used

The information in this document is based on these software and hardware versions:

- Cisco PGW 2200 Releases 9.4(1) and later
- Cisco HSI verion 4.1

Note: Both running on the latest patch level available on Cisco.com.

The information in this document was created from the devices in a specific lab environment. All of the devices used in this document started with a cleared (default) configuration. If your network is live, make sure that you understand the potential impact of any command.

Conventions

For more information on document conventions, refer to the Cisco Technical Tips Conventions.

Cisco PGW 2200 and HSI – DTMF Out-of-band

The Cisco PGW 2200 supports DTMF relay for both SIP and H.323.

H.323

The Cisco PGW 2200 and HSI support out-of-band DTMF relay. DTMF digits from the media gateway (MGW) are sent to the Cisco PGW 2200 through Media Gateway Control Protocol (MGCP), and send over via Extended-ISDN User Part (E-ISUP) messages to the Cisco HSI. This results in a H.245 message from the Cisco HSI towards a gatekeeper.

Figure 1 – DTMF H.323

	DTMF in Bearer or Signal Path	Supported H323 Version
RFC 2833 (NTE)	Bearer	V.4
H.245 Alphanumeric	Signal	v.1 & Higher
H.245 Signal	Signal	v.2 & Higher

In Figure 1, the Cisco HSI always transmits as type H.245 "signal." Basically, the Cisco HSI can receive it as either type H.245 "signal" or "alpha."

Figure 2 – DTMF MGCP

DTMF in Bearer or Signal Path	
RFC 2833 (NTE)	Bearer
Out of Band	Signal
NSE	Bearer

For MGW to Cisco PGW 2200 through the **debug mgcp packet** command on the MGW, this information is seen:

```

From debug mgcp packet output
MGCP..... -> NTFY 123 s0/ds1-1/17@mgw04 MGCP 0.1
                                         X: 703
                                         O: D/0 <-----received 0
MGCP..... -> 200 123 OK

```

The H.245 message from Cisco HSI to the gateway through the **debug h245 asn1** command on the gateway tells you details via the H.245 **userInput : signal**.

```

From debug h245 asn1 debug output
00:52:17: H245 MSC INCOMING PDU ::=

value MultimediaSystemControlMessage ::= indication : userInput : signal :
    {
        signalType "5"
    }

!--- Digit relayed is 5.

```

Figure 3 – Cisco PGW 2200 and HSI Concept

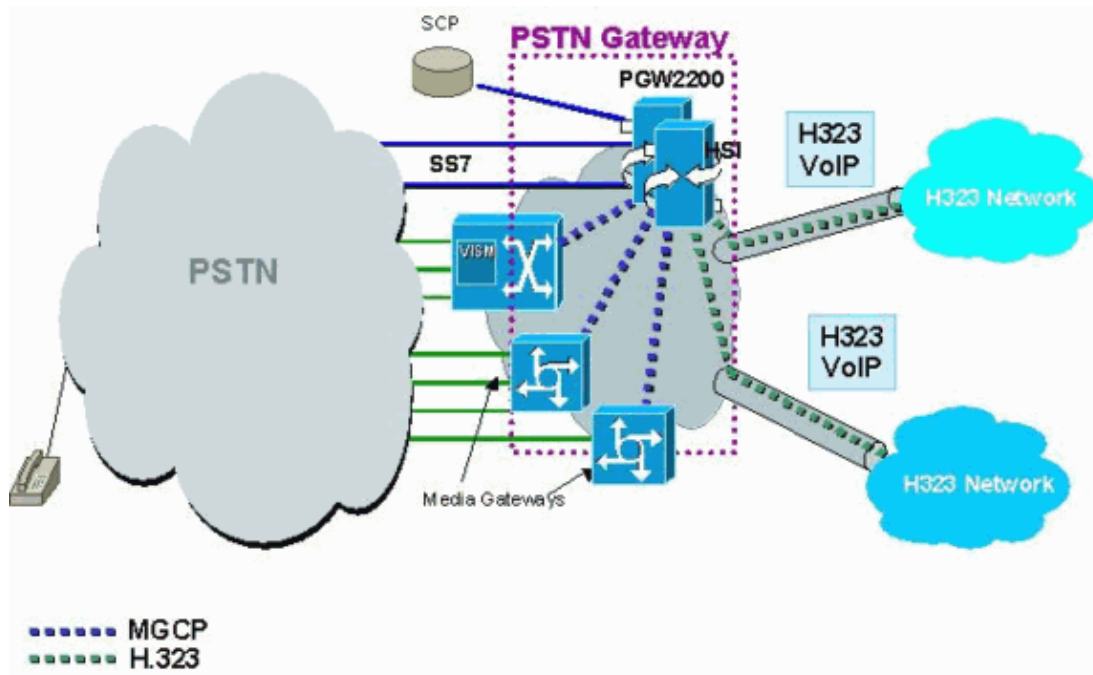

Configuration

On the MGCP gateway, add these commands:

```
mgcp package-capability dtmf-package
mgcp dtmf-relay voip codec all mode out-of-band
```

On the Cisco PGW 2200:

```
Auto-detects
```

On the Cisco IOS H.323 gateway, under the **dial-peer voice xx voip** command, add this command:

```
dtmf-relay h245-signal
```

On the Cisco HSI : (HSI provisioning URL)

```
prov-add:name=sys_config_static, dtmfsupporteddirection=both
prov-add:name=sys_config_static, dtmfsupportedtype=dtmf
```

Example

To configure this on the Cisco HSI:

```
gw mml> prov-sta::srcver="active",dstver="DTMF_Config"
H323 Signalling Gateway Mon Feb 2 13:27:57 2004
M SUCC
```

Successfully started provisioning session "DTMF_Config" from "active."

Note: This provisioning session has not been verified.

```
gw mml> prov-add:name="SYS_CONFIG_STATIC",DtmfSupportedType="dtmf"
H323 Signalling Gateway Mon Feb 2 13:29:18 2004
M SUCC
```

Successfully added provisioning elements:

- MML Name: SYS_CONFIG_STATIC
- Parameter: DtmfSupportedType
- Value: DTMF

```
gw mml> prov-add:name="SYS_CONFIG_STATIC",DtmfSupportedDirection="both"  
H323 Signalling Gateway Mon Feb 2 13:29:41 2004  
M SUCC
```

Successfully added provisioning elements:

- MML Name: SYS_CONFIG_STATIC
- Parameter: DtmfSupportedDirection
- Value: both

```
gw mml> prov-cpy  
H323 Signalling Gateway Mon Feb 2 13:29:49 2004  
M SUCC
```

Note: The HSI needs to be restarted after changing these parameters because they are "static" and therefore only read during a restart.

MGCP DTMF digits can come out of order, due to the MGCP dual Ethernet connection.

- On the sending side, the Cisco IOS AS5xxx detects the digit with a MGCP NTFY with O: D/1 (MGCP notify with observed event digit 1).
- On the receiving side, the Cisco IOS AS5xxx sends the digits with a MGCP RQNT with S: D/1 (MGCP request event while sending the signal digit 1).

In looking for an HSI solution, review the H.245 message which can not come out of order due to the TCP that keeps the message in sequence. This is the same for the E-ISUP links using UDP/RUDP (Reliable UDP). During troubleshooting for such an event, consider the MGCP connection which uses UDP and can result in the digits being duplicated along the path for packet re-transmissions. Also, overload of the Ethernet segment can be another reason for this situation.

SIP

The Cisco PGW 2200 supports out-of-band SIP DTMF from Release 9.4(1) latest patches. When the Cisco PGW 2200 receives a SIP SUBSCRIBE for DTMF, it will inform the MGCP gateway to pass the DTMF up to the Cisco PGW 2200, and then the Cisco PGW 2200 will send a SIP NOTIFY message with the DTMF. From the other direction, if the Cisco PGW 2200 receives an unsolicited SIP NOTIFY message with DTMF, the Cisco PGW 2200 will use MGCP to request the MGW to generate DTMF.

Figure 4 – PGW2200 – SIP

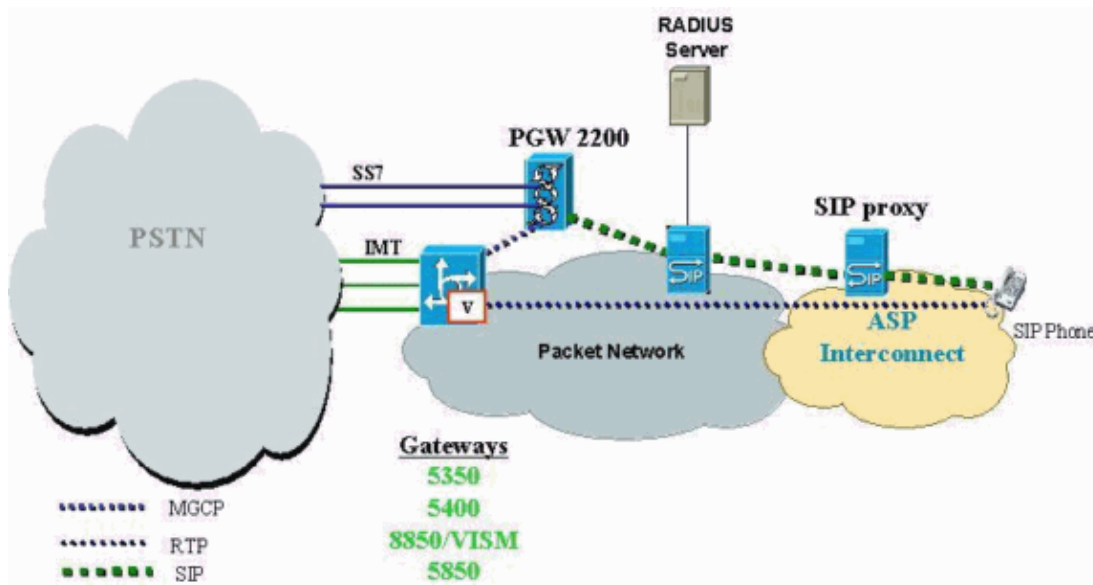

Whether it be solicited or unsolicited, the Endpoint should request NOTIFICATION via a SUBSCRIBE which will cause the Cisco PGW 2200 to send RQNT to the gateway and a NOTIFY when the digits are received. Cisco PGW 2200 will send RQNT to the gateway only after receiving either a SUBSCRIBE message or an unsolicited NOTIFY response message in 18x/200 message.

Figure 5 – DTMF SIP

DTMF in Bearer or Signal Path	
SIP Subscribe/Notify	Signal
RFC 2833 (NTE)	Bearer
SIP Info	Signal

- Solicited via SUBSCRIBE message:

```

SUBSCRIBE sip:abc@cisco.com SIP/2.0
Call-Id: 100@cisco.com
To: <sip:notifier@cisco.com>
From: <tel:+14085554000>;tag=abcd
CSeq: 1 SUBSCRIBE
Events: telephone-event;duration=2000
Expires: 3600
Content-Length: 0

```

SUBSCRIBE is required if the other SIP side wants to know about DTMF digits coming from the PSTN. If

the Cisco PGW 2200 gets SUBSCRIBE, it will request the MGCP gateway to pass DTMF events up MGCP, and the Cisco PGW 2200 will send NOTIFY.

If the Cisco PGW 2200 gets an unsolicited NOTIFY from the SIP side, the Cisco PGW 2200 will request the MGCP gateway to play DTMF towards the PSTN.

NetPro Discussion Forums – Featured Conversations

Networking Professionals Connection is a forum for networking professionals to share questions, suggestions, and information about networking solutions, products, and technologies. The featured links are some of the most recent conversations available in this technology.

NetPro Discussion Forums – Featured Conversations for Voice
Service Providers: Voice over IP
Voice & Video: Voice over IP
Voice & Video: IP Telephony
Voice & Video: IP Phone Services for End Users
Voice & Video: Unified Communications
Voice & Video: IP Phone Services for Developers
Voice & Video: General

Related Information

- [Cisco PGW 2200 Softswitch Tech Notes](#)
- [Cisco Signaling Controllers Technical Documentation](#)
- [Voice Technology Support](#)
- [Voice and Unified Communications Product Support](#)
- [Recommended Reading: Troubleshooting Cisco IP Telephony](#)
- [Technical Support – Cisco Systems](#)

[Contacts & Feedback](#) | [Help](#) | [Site Map](#)

© 2008 – 2009 Cisco Systems, Inc. All rights reserved. [Terms & Conditions](#) | [Privacy Statement](#) | [Cookie Policy](#) | [Trademarks of Cisco Systems, Inc.](#)

Updated: Feb 02, 2006

Document ID: 49923