

# Remote to Remote Network with the Cisco Multiservice IP-to-IP Gateway Feature

Document ID: 48304

---

## Introduction

### Prerequisites

Requirements

Components Used

Conventions

### Background Information

### Configure

Network Diagram

Configurations

### Verify

### Troubleshoot

Troubleshooting Procedure

Troubleshooting Commands

### NetPro Discussions for Voice

### Related Information

---

## Introduction

This document provides a sample configuration for a remote to remote network using the Cisco Multiservice IP-to-IP Gateway (IPIP GW) feature. The IPIP GW feature provides a mechanism to enable H.323 Voice over IP (VoIP) calls from one IP network to another.

## Prerequisites

### Requirements

Before attempting this configuration, please ensure that you meet these requirements:

- Perform basic H.323 gateway configuration. For detailed instructions, see the Cisco IOS H.323 Configuration Guide, Cisco IOS Voice Configuration Library, Release 12.3.
- Perform basic H.323 gatekeeper configuration. For detailed instructions, see the Cisco IOS H.323 Configuration Guide, Cisco IOS Voice Configuration Library, Release 12.3.

### Components Used

The information in this document is based on these software and hardware versions:

- Three Cisco H.323 Gatekeeper Routers (Cisco 2610, Cisco 2611, Cisco 2612, Cisco 2613, Cisco 2620, Cisco 2621, Cisco 2650, Cisco 2651, Cisco 2691, Cisco 2610XM, Cisco 2611XM, Cisco 2620XM, Cisco 2621XM, Cisco 2650XM, Cisco 2651XM, Cisco 3620, Cisco 3649, Cisco 3660, Cisco 3725, Cisco 3745, Cisco 7200 series, or Cisco 7400 series) with Cisco IOS Software Release 12.3(4)T or later.

The information presented in this document was created from devices in a specific lab environment. All of the devices used in this document started with a cleared (default) configuration. If you are working in a live

network, ensure that you understand the potential impact of any command before using it.

## Conventions

For more information on document conventions, refer to Cisco Technical Tips Conventions.

## Background Information

The Cisco Multiservice IPIPGW feature introduces gatekeeper via-zones. Via-zone is a Cisco term for a zone that contains IP-to-IP gateways and via-zone-enabled gatekeepers. A via-zone-enabled gatekeeper is capable of recognizing via-zones and sending traffic to via-zone gateways. Cisco via-zone enabled gatekeepers include a via-zone command-line interface (CLI) command.

Via-zones are usually located on the edge of an ITSP network, and are like a VoIP transfer point, or tandem zone, where traffic passes through on the way to the remote zone destination. Gateways in this zone terminate requested calls and re-originate traffic to its final destination. Via-zone gatekeepers operate as usual for non-IP to IP applications. Gatekeepers in via-zones support resource management (for example, gateway selection and load balancing) using the capacities field in the H.323 Version 4 RAS messages.

## Configure

In this section, you are presented with the information to configure the features described in this document.

**Note:** To find additional information on the commands used in this document, use the Command Lookup Tool (registered customers only).

## Network Diagram

This document uses this network setup:

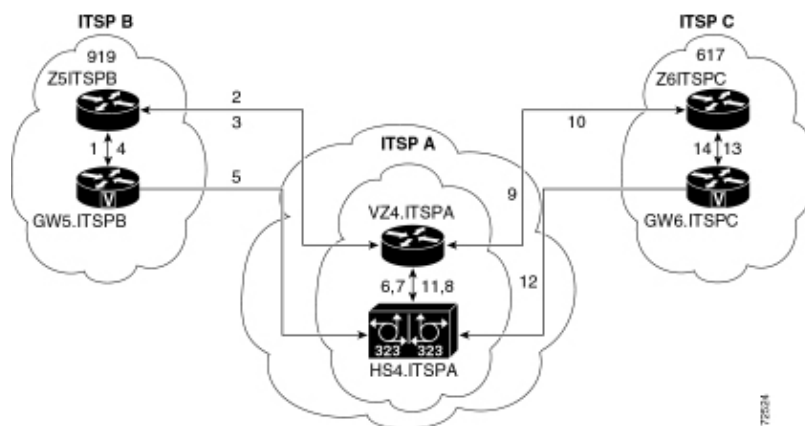

## Configurations

This document uses these configurations:

- Originating Gatekeeper (Z5.ITSPB)
- Via-zone Gatekeeper (VZ4.ITSPA)
- Terminating Gatekeeper (Z6.ITSPC)

In this example, a caller from area code 919 calls a party in area code 617, and the following actions occur:

1. GW5.ITSPB sends an ARQ with the 617-based number to GK Z5.ITSPB.
2. Z5.ITSPB sees prefix 617 as reachable through VZ4.ITSPA, so Z5.ITSPB sends an LRQ to VZ4.ITSPA
3. The LRQ for 617 is received by VZ4.ITSPA. VZ4.ITSPA looks at the H.323 ID in the inbound LRQ to find the remote zone. Then it looks for a via-zone keyword associated with that remote zone. Since the via-zone gatekeeper ID is a local zone, it allocates the call to the IP-to-IP gateway in the via-zone and sends back an LCF specifying HS4.ITSPA.
4. Z5.ITSPB returns the ACF, specifying HS4.ITSPA.
5. GW5.ITSPB sends a SETUP message to HS4.ITSPA for the 617 call.
6. HS4.ITSPA sends an ARQ to VZ4.ITSPA to admit the incoming call (answerCall=true).
7. VZ4.ITSPA returns an ACF.
8. HS4.ITSPA has a dial peer specifying ras VZ4.ITSPA for the 617 prefix (or all prefixes), and sends an ARQ (with answerCall set to FALSE) to VZ4.ITSPA for prefix 617.
9. VZ4.ITSPA sees prefix 617 as Z6.ITSPC, and there is no outvia zone, so VZ4.ITSPA sends an LRQ to Z6.ITSPC.
10. Z6.ITSPC sees prefix 617 as in its own zone and sends an LCF pointing to GW6.ITSPC.
11. VZ4.ITSPA returns an ACF specifying GW6.ITSPC.
12. HS4.ITSPA sends a SETUP message to GW6.ITSPC for the 617 call.
13. GW6.ITSPC sends an ARQ answerCall to Z6.ITSPC.
14. Z6.ITSPC returns an ACF for answerCall.

#### Originating Gatekeeper (Z5.ITSPB)

```

origgatekeeper# show running-config
Building configuration...
.
.
.
gatekeeper
zone local Z5ITSPB zone1 10.16.6.158
zone remote VZ4ITSPA zone2 10.16.10.139 1719
zone prefix VZ4ITSPA 617*
.
.
.
!
end

```

#### Via-zone Gatekeeper (VZ4.ITSPA)

```

vzgatekeeper# show running-config
Building configuration...
.
.
.
gatekeeper
zone local VZ4ITSPA zone2 10.16.10.139
zone remote Z6ITSPC zone3 10.16.2.144 1719 outvia VZ4ITSPA
zone remote Z5ITSPB zone1 10.16.6.158 invia VZ4ITSPA
zone prefix Z6ITSPC 617*
.
.
.
!
end

```

#### Terminating Gatekeeper (Z6.ITSPC)

```

termgatekeeper# show running-config
Building configuration...

```

```

.
.
.
gatekeeper
  zone local Z6ITSPC zone3 10.16.2.144
.
.
.
!
end

```

## Verify

This section provides information you can use to confirm your configuration is working properly.

Certain **show** commands are supported by the Output Interpreter Tool ( registered customers only ) , which allows you to view an analysis of **show** command output.

The following **show** command outputs were obtained from the VZ.ITSPA Gatekeeper.

To verify gatekeeper configuration, use the **show running config | begin gatekeeper** command:

```

gatekeeper
zone local VZ4ITSPA zone2 10.16.10.139
zone remote Z6ITSPC zone3 10.16.2.144 1719 outvia VZ4ITSPA
zone remote Z5ITSPB zone1 10.16.6.158 invia VZ4ITSPA
zone prefix Z6ITSPC 617*
          no shutdown

```

You can also use the **show gatekeeper zone status** command to verify gatekeeper configuration:

```

GATEKEEPER ZONES
=====
GK name          Domain Name      RAS Address      PORT  FLAGS
-----          -
VZ4ITSPA         zone2            10.16.128.40    1719  LSV
BANDWIDTH INFORMATION (kbps) :
  Maximum total bandwidth :unlimited
  Current total bandwidth :0
  Maximum interzone bandwidth :unlimited
  Current interzone bandwidth :0
  Maximum session bandwidth :unlimited
  Total number of concurrent calls :3
SUBNET ATTRIBUTES :
  All Other Subnets :(Enabled)
PROXY USAGE CONFIGURATION :
  Inbound Calls from all other zones :
    to terminals in local zone hurricane :use proxy
    to gateways in local zone hurricane :do not use proxy
    to MCUs in local zone hurricane :do not use proxy
  Outbound Calls to all other zones :
    from terminals in local zone hurricane :use proxy
    from gateways in local zone hurricane :do not use proxy
    from MCUs in local zone hurricane :do not use proxy

Z1.ITSPA         zone2            10.16.10.139    1719  RS
VIAZONE INFORMATION :
  invia:VZ4.ITSPA,  outvia:VZ4.ITSPA

Z5.ITSPB         zone2            10.16.8.144     1719  RS
VIAZONE INFORMATION :

```

invia:VZ4.ITSPA, outvia:VZ4.ITSPA

Enter the **show gatekeeper status** command to view call capacity thresholds:

```
Gatekeeper State: UP
  Load Balancing:   DISABLED
  Flow Control:     DISABLED
  Zone Name:        hurricane
  Accounting:       DISABLED
  Endpoint Throttling:  DISABLED
  Security:         DISABLED
  Maximum Remote Bandwidth: unlimited
  Current Remote Bandwidth: 0 kbps
  Current Remote Bandwidth (w/ Alt GKs): 0 kbps
```

Enter the **show gatekeeper performance stats** command to view RAS information, including via-zone statistics:

```
Performance statistics captured since: 08:16:51 GMT Tue Jun 11 2002

RAS inbound message counters:
  Originating ARQ: 462262 Terminating ARQ: 462273 LRQ: 462273
RAS outbound message counters:
  ACF: 924535 ARJ: 0 LCF: 462273 LRJ: 0
  ARJ due to overload: 0
  LRJ due to overload: 0

RAS viazone message counters:
  inLRQ: 462273 infwdLRQ 0 inerrLRQ 0
  outLRQ: 0 outfwdLRQ 0 outerrLRQ 0
  outARQ: 462262 outfwdARQ 0 outerrARQ 0
Load balancing events: 0
Real endpoints: 3
```

The following table describes the significant RAS via-zone fields shown in the display.

Field	Description
inLRQ	Associated with the invia keyword. If the invia is a local zone, this counter identifies the number of LRQs terminated by the local invia gatekeeper.
infwdLRQ	Associated with the invia keyword. If the invia is a remote zone this counter identifies the number of LRQs that were forwarded to the remote invia gatekeeper.
inerrLRQ	Associated with the invia keyword. Number of times the LRQ could not be processed because the invia gatekeeper ID could not be found. Usually caused by a misspelled gatekeeper name.
outLRQ	Associated with the outvia keyword. If the outvia is a local zone, this counter identifies the number of LRQs terminated by the local outvia gatekeeper. This counter applies only in configurations where no invia gatekeeper is specified.
outfwdLRQ	Associated with the outvia keyword. If the outvia is a remote zone, this counter identifies the number of LRQs that were forwarded to the remote outvia

	gatekeeper. This counter applies only in configurations where no invia gatekeeper is specified.
outerrLRQ	Associated with the outvia keyword. Number of times the LRQ could not be processed because the outvia gatekeeper ID could not be found. Usually caused by a misspelled gatekeeper name. This counter applies only in configurations where no invia gatekeeper is specified.
outARQ	Associated with the outvia keyword. Identifies the number of originating ARQs handled by the local gatekeeper if the outvia is that local zone.
outfwdARQ	Associated with the outvia keyword. If the outvia gatekeeper is a remote zone, this number identifies the number of originating ARQs received by this gatekeeper that resulted in LRQs being sent to the outvia gatekeeper.
outerrARQ	Associated with the outvia keyword. Number of times the originating ARQ could not be processed because the outvia gatekeeper ID could not be found. Usually caused by a misspelled gatekeeper name.

Enter the **show gatekeeper circuit** command to view information on calls in progress:

```

                                CIRCUIT INFORMATION
                                =====
Circuit      Endpoint      Max Calls Avail Calls Resources      Zone
-----
ITSP B      Total Endpoints: 1
            hs4.itspa 200          198          Available

```

**Note:** The word `calls` refers to call legs in some commands and output.

Enter the **show gatekeeper endpoint** command to view information on endpoint registrations:

```

                                GATEKEEPER ENDPOINT REGISTRATION
                                =====
CallSignalAddr  Port  RASignalAddr  Port  Zone Name      Type  Flags
-----
10.16.10.140   1720  10.16.10.140  50594  vz4.itspa      H323-GW
      H323-ID: hs4.itspa
      H323 Capacity Max.= 200 Avail.= 198
Total number of active registrations = 1

```

## Troubleshoot

This section provides information you can use to troubleshoot your configuration.

### Troubleshooting Procedure

Below is troubleshooting information relevant to this configuration. For additional information on troubleshooting, see Cisco Multiservice IP-to-IP Gateway. Follow the instructions below to troubleshoot

your configuration.

The procedures for troubleshooting an IPIPGW are similar to troubleshooting a TDM-to-IP H.323 gateway. Generally, your troubleshooting efforts should proceed as follows:

1. Isolate and reproduce the failing scenario.
2. Collect relevant information from **debug** and **show** commands, configuration files, and protocol analyzers.
3. Identify the first indication of failure in protocol traces or internal debug output.
4. Look for the cause in configuration files.

If the via-zone is suspected as the source of a call failure, isolate the problem to an IPIPGW or gatekeeper by identifying affected the subfunction and focus on show and debug commands related to that subfunction.

Before you can begin troubleshooting, you first must isolate the problem to either a gateway or gatekeeper. Gateways and gatekeepers are responsible for the following tasks:

### Gateway Tasks

- Media stream handling and speech path integrity
- DTMF relay
- Fax relay and passthrough.
- Digit translation and call processing
- Dial-peers and codec filtering
- Carrier ID handling
- Gateway-based billing

### Gatekeeper Tasks

- Gateway selection and load balancing
- Call routing (zone selection)
- Gatekeeper-based billing
- Control of call admission, security, and bandwidth
- Enforcement of call capacities

## Troubleshooting Commands

Certain **show** commands are supported by the Output Interpreter Tool ( registered customers only ) , which allows you to view an analysis of **show** command output.

**Note:** Before issuing **debug** commands, please see Important Information on Debug Commands.

### Gateway debug Commands

- **debug voip ipipgw** This command displays information related to the handling of IP-to-IP calls
- **debug h225 asn1** This command displays the actual contents of the asn1 part of H.225 messages and associated events.
- **debug h225 events** This command displays the actual contents of the asn1 part of H.225 messages and associated events.
- **debug h245 asn1** This command displays the actual contents of the asn1 part of H.245 messages and associated events.
- **debug h245 events** This command displays the actual contents of the asn1 part of H.245 messages and associated events.

- **debug cch323 all** When **debug cch323** is used with **h225**, **h245**, or **ras** keywords, the debug output traces the state transitions of the associated state machines based on the processed events.
- **debug voip ccapi inout** This command traces the execution path through the call control API, which serves as the interface between the call session application and the underlying network-specific software.
- **debug voice ccapi error** This command traces the error logs in the call control API. Error logs are generated during normal call processing when there are insufficient resources or when there are problems in the underlying network-specific code, the higher call session application, or the call control API itself.

### Gatekeeper debug Commands

- **debug h225 asn1** This command displays the actual contents of the asn1 portion of H.225 RAS messages and associated events.
- **debug h225 events** This command displays the actual contents of the asn1 portion of H.225 RAS messages and associated events.
- **debug gatekeeper main 10** This command traces major gatekeeper functions, such as LRQ processing, gateway selection, admission request processing, prefix matching, and call capacities.
- **debug gatekeeper zone 10** This command traces gatekeeper zone-oriented functions.
- **debug gatekeeper call 10** This command traces gatekeeper call-oriented functions, such as tracking call references.
- **debug gatekeeper gup asn1** This command displays the actual contents of the asn1 portion of gatekeeper update protocol messages and associated events for communication between gatekeepers in a cluster.
- **debug gatekeeper gup events** This command displays the actual contents of the asn1 portion of gatekeeper update protocol messages and associated events for communication between gatekeepers in a cluster.
- **debug ras** This command displays the types and addressing of RAS messages sent and received.

### Gateway show Commands

- **show h323 gateway h225** This command maintains counts of H.225 messages and events.
- **show h323 gateway ras** This command maintains counts of RAS messages sent and received.
- **show h323 gateway cause** This command shows counts of cause codes received from connected gateways.
- **show call active voice [brief]** These commands aggregate information about active and cleared calls.
- **show crm** This command shows the call capacity counts associated with IP circuits on the IPIPGW.
- **show processes cpu** This command shows detailed CPU utilization statistics (CPU use per process).
- **show gateway** This command shows the current status of the gateway.

### Gatekeeper show Commands

- **show/clear gatekeeper performance stats** This command shows the gatekeeper statistics associated with processing calls.
- **show gatekeeper zone status** This command lists information about the local and remote zones known to the gatekeeper.
- **show gatekeeper endpoint** This command lists key information about the endpoints registered to the gatekeeper, including IPIPGWs.
- **show gatekeeper circuit** This command combines information about circuit utilization across multiple gateways.
- **show gatekeeper calls** This command lists key information about calls being handled in the local zone.

# NetPro Discussions for Voice

Networking Professionals Connection is a forum for networking professionals to share questions, suggestions, and information about networking solutions, products, and technologies. The featured links are some of the most recent conversations available in this technology.

NetPro Discussion Forums – Featured Conversations for Voice
Service Providers: Voice over IP
Voice & Video: Voice over IP
Voice & Video: IP Telephony
Voice & Video: IP Phone Services for End Users
Voice & Video: Unified Communications
Voice & Video: IP Phone Services for Developers
Voice & Video: General

## Related Information

- [Voice Technology Support](#)
- [Voice and Unified Communications Product Support](#)
- [Recommended Reading: Troubleshooting Cisco IP Telephony](#)
- [Technical Support – Cisco Systems](#)

---

[Contacts & Feedback](#) | [Help](#) | [Site Map](#)

© 2008 – 2009 Cisco Systems, Inc. All rights reserved. [Terms & Conditions](#) | [Privacy Statement](#) | [Cookie Policy](#) | [Trademarks of Cisco Systems, Inc.](#)

---

Updated: Feb 02, 2006

Document ID: 48304

---