

Auxiliary Port, Console Port, and Adapter Pinouts for Cisco 1000, 1600, 2500, 2600, and 3600 Series Routers

Document ID: 46789

Introduction

Prerequisites

Requirements

Components Used

Conventions

Auxiliary and Console Ports

Identify a Rollover Cable

Console Port Connection to a PC

Console Port Signaling and Cabling with a DB-9 Adapter

Console Port Signaling and Cabling with a DB-25 Adapter

Auxiliary Port Connection to a Modem

Auxiliary Port Signaling and Cabling Using a DB-25 Adapter

Alternative Terminal and Modem Connections

NetPro Discussion Forums – Featured Conversations

Related Information

Introduction

This document explains the different ports and adapter pinouts for Cisco 1000, 1600, 2500, 2600, and 3600 Series Routers.

Prerequisites

Requirements

There are no specific requirements for this document.

Components Used

The information in this document is based on these software and hardware versions:

- Cisco 1000, 1600, 2500, 2600, and 3600 Series Routers

The information in this document was created from the devices in a specific lab environment. All of the devices used in this document started with a cleared (default) configuration. If your network is live, make sure that you understand the potential impact of any command.

Conventions

Refer to Cisco Technical Tips Conventions for more information on document conventions.

Auxiliary and Console Ports

The console and auxiliary ports on Cisco IOS® routers are asynchronous serial ports. The console port and the auxiliary port are configured as data terminal equipment (DTE). For Cisco 1000, 1600, 2500, 2600, and 3600 Series Routers, the console and auxiliary ports both use RJ-45 connectors. Adapters are available for connections to PC terminals, modems, or other external communications equipment.

This table shows the console port pinouts for the RJ-45 connector:

Console Port (DTE)		
Pin ¹	Signal	Input/Output
1	—	—
2	DTR	Output
3	TxD	Output
4	GND	—
5	GND	—
6	RxD	Input
7	DSR	Input
8	—	—

¹Any pin not referenced is not connected.

This table shows the auxiliary port pinouts of the RJ-45 connector:

Auxiliary Port (DTE)		
Pin ²	Signal	Input/Output
1	RTS	Output
2	DTR	Output
3	TXD	Output
4	GND	—
5	GND	—
6	RXD	Input
7	DSR	Input
8	CTS	Input

²Any pin not referenced is not connected.

Identify a Rollover Cable

In order to identify a rollover cable, compare the two modular ends of the cable. Hold the cables in your hand, side-by-side, with the tab at the back. The wire connected to the pin on the outside of the left connector (pin 1) must be the same color as the pin on the outside of the right connector (pin 8). On Cisco cables, pin 1 is white on one connector, and pin 8 is white on the other connector.

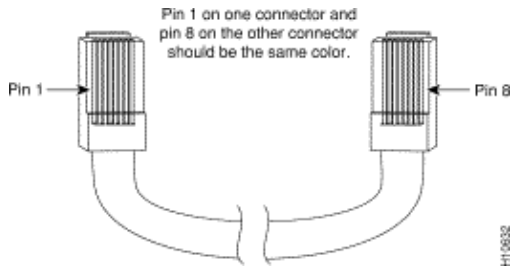

This table shows the RJ-45 rolled (console) cable pinouts:

Signal	Pin	Pin	Signal
—	1	8	—
—	2	7	—
—	3	6	—
—	4	5	—
—	5	4	—
—	6	3	—
—	7	2	—
—	8	1	—

Console Port Connection to a PC

To connect a PC terminal to the console port, use the RJ-45-to-RJ-45 rollover cable, and either the RJ-45-to-DB-25 female DTE adapter or the RJ-45-to-DB-9 female DTE adapter (labeled "TERMINAL").

The default parameters for the console port are:

- 9600 baud
- 8 data bits
- No parity generated or checked
- 1 stop bit
- No Flow Control

Console Port Signaling and Cabling with a DB-9 Adapter

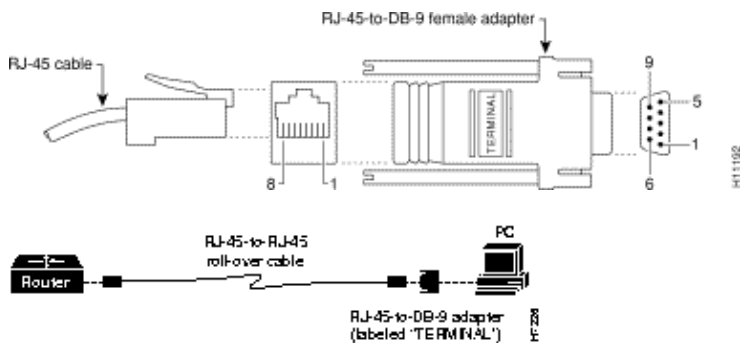

The next table shows the pinout descriptions for the DB-9 connections:

--	--	--	--

Console Port (DTE)	RJ-45-to-RJ-45 Rollover Cable		RJ-45-to-DB-9 Terminal Adapter	Console Device
Signal	RJ-45 Pin	RJ-45 Pin	DB-9 Pin	Signal
RTS	1 ³	8	8	CTS
DTR	2	7	6	DSR
TxD	3	6	2	RxD
GND	4	5	5	GND
GND	5	4	5	GND
RxD	6	3	3	TxD
DSR	7	2	4	DTR
CTS	8	1	7	RTS

³Pin 1 is connected internally to Pin 8.

Console Port Signaling and Cabling with a DB-25 Adapter

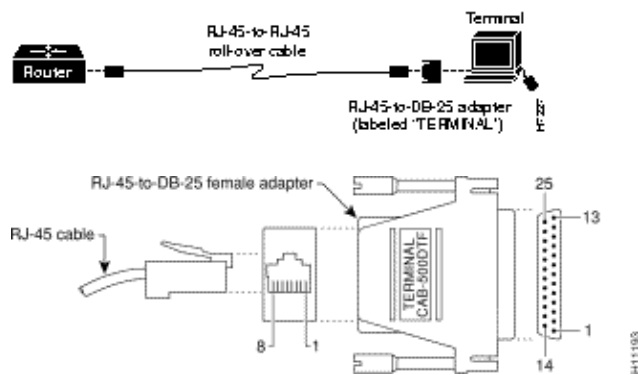

The next table shows the pinout descriptions for the DB-25 connections:

Console Port (DTE) ⁴	RJ-45-to-RJ-45 Rollover Cable		RJ-45-to-DB-25 Terminal Adapter	Console Device
Signal	RJ-45 Pin	RJ-45 Pin	DB-25 Pin	Signal
RTS	1 ⁵	8	5	CTS
DTR	2	7	6	DSR
TxD	3	6	3	RxD
GND	4	5	7	GND
GND	5	4	7	GND
RxD	6	3	2	TxD
DSR	7	2	20	DTR
CTS	8	1	4	RTS

⁴You can use the same cabling to connect a console to the auxiliary port.

⁵Pin 1 is connected internally to Pin 8.

Auxiliary Port Connection to a Modem

In order to connect a PC terminal to the router, use the RJ-45-to-RJ-45 roll-over cable and either the RJ-45-to-DB-25 female DTE adapter or the RJ-45-to-DB-9 female DTE adapter (labeled "TERMINAL"). This section lists the pinout descriptions for both DB-9 and DB-25 connections.

In order to connect a modem to the auxiliary port, use the RJ-45-to-RJ-45 rollover cable and the RJ-45-to-DB-25 male DCE adapter (labeled "MODEM").

Auxiliary Port Signaling and Cabling Using a DB-25 Adapter

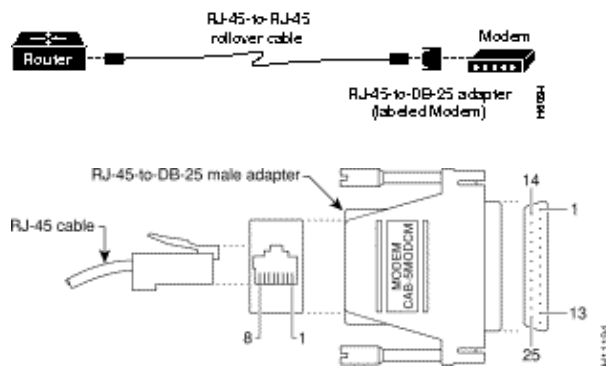

Here is the pinout description for the modem connection:

Auxiliary Port (DTE)	RJ-45-to-RJ-45 Rollover Cable		RJ-45-to-DB-25 Modem Adapter	Modem Signal
Signal	RJ-45 Pin	RJ-45 Pin	DB-25 Pin	Signal
RTS	1 ⁶	8	4	RTS
DTR	2	7	20	DTR
TxD	3	6	3	TxD
GND	4	5	7	GND
GND	5	4	7	GND
RxD	6	3	2	RxD
DSR	7	2	8	DCD
CTS	8	1	5	CTS

⁶Pin 1 is connected internally to Pin 8.

Alternative Terminal and Modem Connections

Cisco Port Connection	RJ-45 Cable Type	Adapter
Console port to PC	Straight-through	

		DCE, DB-9 female
Console port to terminal	Straight-through	DCE, DB-25 female
Auxiliary port to modem	Rollover ⁷	DCE ⁸ , DB-25, male
-	Straight-through	DTE ⁸ , DB-25, male

⁷An octal cable or RJ-45 breakout cable is equivalent to a rollover cable.

⁸Modify the DB-25 adapter by removing pin 6 and placing it into the pin 8 position.

NetPro Discussion Forums – Featured Conversations

Networking Professionals Connection is a forum for networking professionals to share questions, suggestions, and information about networking solutions, products, and technologies. The featured links are some of the most recent conversations available in this technology.

NetPro Discussion Forums – Featured Conversations for Router and IOS Architecture
Network Infrastructure: LAN Routing and Switching
Network Infrastructure: WAN Routing and Switching

Related Information

- [Cabling Guide for Console and AUX Ports](#)
- [Technical Support & Documentation – Cisco Systems](#)

All contents are Copyright © 2006–2007 Cisco Systems, Inc. All rights reserved. Important Notices and Privacy Statement.

Updated: Jan 27, 2006

Document ID: 46789