

Cisco Unity 3.1(6) Installation Guide: Installing Voice Boards

Document ID: 44328

Introduction

Prerequisites

- Requirements

- Components Used

- Conventions

Task 1: Install the Cisco Unity Voice Cards

- Install Cisco Unity Voice Cards

Appendix A: Configure the Intel Dialogic D/41E PCI

- Hardware Settings

Appendix B: Configure the Intel Dialogic D/120JCT-LS and D/120JCT-EURO

- Hardware Settings

Appendix C: Configure the Intel Dialogic D/240PCI-T1

- Hardware Settings

NetPro Discussion Forums – Featured Conversations

Related Information

Introduction

Note: This document is part of a set of documents that explain how to determine which Cisco Unity installation option is correct for your network. These documents also explain how to install the correct Cisco Unity option in your network. The use of these documents is meant only for new Cisco Unity installations. If you upgrade or otherwise change an existing Cisco Unity configuration, refer to the correct online product documentation for Cisco Unity.

Note: These documents do not explain how to integrate your Cisco Unity server with your phone system or how to configure your Cisco Unity server. Once you complete the initial Cisco Unity installation, you have to refer to the online product documentation for further instructions. Refer to the Next Steps section on the Index page.

Note: This document set is written for networks that run a Windows 2000 server.

Note: Return to the Index page for this documentation set.

This document explains how to perform the tasks that are necessary in order to install Cisco Unity Voice Cards into a server. Some cards require additional software configuration changes on the server after the installation of Cisco Unity is complete. The Cisco Unity 3.1(6) Installation Guide: Voice Board Software Configuration document explains these tasks. The Index page for this documentation set provides the link to this document at the appropriate stage of the server configuration process.

The use of this document is meant only for new installations. For information on how to add, exchange, or remove voice cards in an existing Cisco Unity 3.1 system, refer to the Adding, Exchanging, or Removing Voice Cards section of Upgrading a Cisco Unity 3.0 or 3.1 System.

Prerequisites

Requirements

There are no specific requirements for this document.

Components Used

The information in this document is based on these software and hardware versions:

- Intel Dialogic D/41E PCI
- Intel Dialogic D/120JCT–LS and D/120JCT–EURO
- Intel Dialogic D/240PCI–T1

The information in this document was created from the devices in a specific lab environment. All of the devices used in this document started with a cleared (default) configuration. If your network is live, make sure that you understand the potential impact of any command.

Conventions

For more information on document conventions, refer to the Cisco Technical Tips Conventions.

Task 1: Install the Cisco Unity Voice Cards



Warning: Before you work on a system that has an on/off switch, turn OFF the power and unplug the power cord.



Warning: Before you open the chassis, disconnect the telephone–network cables in order to avoid contact with telephone–network voltages.



Warning: Do not work on the system or connect or disconnect cables during periods of lightning activity.



Warning: In order to reduce the risk of fire, use only No. 26 AWG or a larger telecommunication line cord.



Warning: Only trained and qualified personnel must install, replace, or service this equipment.



Warning: As per the definition by AS/NZS 3260 Clause 1.2.14.3 Service Personnel, only service personnel must install and maintain this equipment.



Warning: The safety cover is an integral part of the product. Do not operate the unit without the safety cover installed. If you operate the unit without the cover in place, it invalidates the safety approvals and poses a risk of fire and electrical hazards.



Warning: Blank faceplates and cover panels serve three important functions. They prevent exposure

to hazardous voltages and currents inside the chassis, they contain electromagnetic interference (EMI) that can disrupt other equipment, and they direct the flow of cooling air through the chassis. Do not operate the system unless all cards, faceplates, front covers, and rear covers are in place.

Install Cisco Unity Voice Cards

Use this procedure in order to install Cisco Unity Voice Cards:

1. If the server is turned on, shut it down.



Caution: If you already have a Windows 2000 Server installed on the server, you need to use

the Windows Shutdown option before you switch the power off. Failure to do this can lead to hard disk corruption.

2. Attach an antistatic wrist strap and ground yourself to the Cisco Unity server.



Warning: During this procedure, wear grounding wrist straps in order to avoid electrostatic

discharge (ESD) damage to the card. Do not directly touch the backplane with your hand or any metal tool, or you can shock yourself.

3. Set the switches and jumpers on each card as appropriate.

- ◆ Intel Dialogic D/41E PCI
- ◆ Intel Dialogic D/120JCT-LS and D/120JCT-EURO
- ◆ Intel Dialogic D/240PCI-T1

Note: Some cards include hardware settings that indicate which card is the first, which is the second, and so on. If you install more than one card of the same model, keep the cards in order so you can install them in the correct order in step 4.

4. Insert each card firmly into its slot and fasten each card to the computer backplate with a screw.

If you install more than one card of the same model, and if the cards include a hardware setting that indicates which card is the first, the second, and so on, install the cards in the order that the hardware settings specify.

If you install cards of different models in the same server, install cards of the same model adjacent to one another.

PCI cards can be put into either 32-bit or 64-bit 33-MHz PCI slots.

You must install all the cards with H.100 bus (also known as CT bus) connectors in the same server. If all the cards do not fit in the Cisco Unity server, then you must install all of them in an expansion chassis.

5. If you install multiple voice cards that have H.100 bus connectors, cable the cards together.

On each card, connect the cable so the red stripe on the cable corresponds with pin 1 on the card connector. Confirm that the connectors are firmly seated.



Caution: If you do not cable cards together properly, the voice card software does not start and

Cisco Unity does not answer calls.

If the cable has more connectors than the server has voice cards, use the first and the last connectors, and leave the unused connectors in the middle of the cable. If the end of a cable dangles loose, it can act as a radio antenna and pick up noise from the bus.

If you cable three or more cards together, connect the first connector on the cable to the first card, the second connector to the second card, and so on.

Return to the Index page for this documentation set.

Appendix A: Configure the Intel Dialogic D/41E PCI

The D/41E PCI voice card provides four independent voice-processing ports in a single PCI slot. The card connects four phone-line interface circuits directly to analog loop-start lines with the help of RJ-11 connectors.

If you install cards that have H.100 connectors, you need an H.100 cable that has at least as many connectors as you have cards (you must connect all cards with the use of a single cable) but no more than five extra connectors.

Figure A-1 represents the D/41E PCI top and side views.

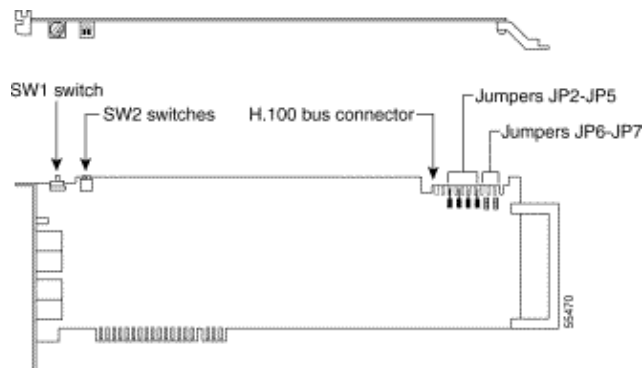
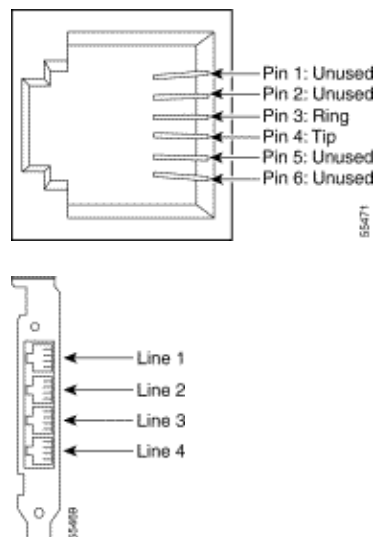

Figure A-2 represents D/41E PCI connection pinouts and backplate.



Hardware Settings

Use this procedure in order to set switches and jumpers:

1. Set the rotary switch (SW1) to a unique value.

Each Intel Dialogic card with a rotary switch in the Cisco Unity server, regardless of model number, must have a unique value which starts with 1 and continues in sequence on subsequent cards. For example, set the rotary switch on the first three voice cards as shown in this figure. This is also the order in which you install the cards in the server.

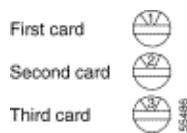

2. Set the SW2 switches to **Off** on each card.
3. Settings for jumpers JP2 through JP5 depend on the number of D/41E PCI voice cards in the Cisco Unity server.

One card	Set jumpers JP2 through JP5 to Off (Figure A-3) on the card.
Two cards	Set jumpers JP2 through JP5 to On (Figure A-4) on both cards.
Three or more cards	Set jumpers JP2 through JP5 to On (Figure A-4) on the first and last cards. Set jumpers JP2 through JP5 to Off (Figure A-3) on all the other cards.

Figure A-3 represents D/41E PCI Jumpers JP2 through JP5: Off



Figure A-4 represents D/41E PCI Jumpers JP2 through JP5 in the On position.



Return to Task 1: Step 4.

4. On jumpers JP6 and JP7, install shunts on the top two pins (1 and 2).



Appendix B: Configure the Intel Dialogic D/120JCT-LS and D/120JCT-EURO

The D/120JCT-LS and D/120JCT-EURO voice cards each provide twelve channels of call-processing and loop-start interfaces in a single PCI slot. North America, South America, and Japan use the D/120JCT-LS. Europe, Australia, and New Zealand use the D/120JCT-EURO. The cards connect twelve analog loop-start phone lines to twelve onboard call-processing resources with the help of RJ-14 connectors.

If you install cards that have H.100 connectors, you need an H.100 cable that has at least as many connectors as you have cards (you must connect all cards with the use of a single cable) but no more than five extra connectors.

Figure A-5 represents D/120JCT-LS and D/120JCT-EURO top and side views.

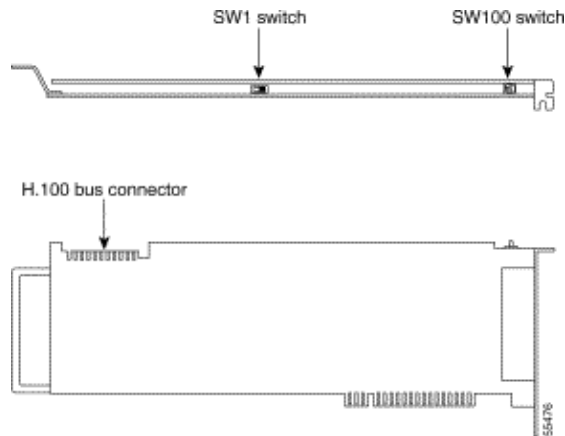
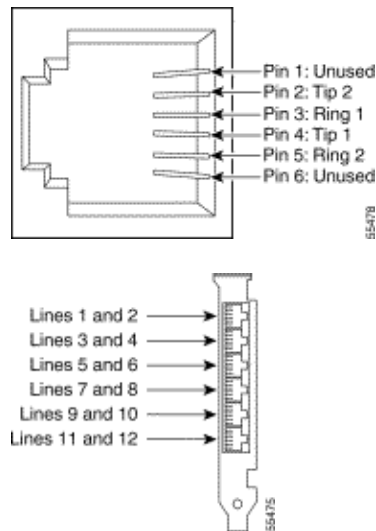

Figure A-6 represents D/120JCT-LS and D/120JCT-EURO connection pinouts and backplate.



Hardware Settings

Use this procedure in order to set switches:

1. Set the rotary switch (SW100) to a unique value.

Each Intel Dialogic card with a rotary switch in the Cisco Unity server, regardless of model number, must have a unique value which starts with 1 and continues in sequence on subsequent cards. For example, set the rotary switch on the first three voice cards as shown in this figure. This is also the order in which you install the cards in the server.

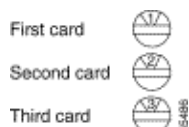

2. Set the SW1 switch to On hook on each card.



Return to Task 1: Step 4.

Appendix C: Configure the Intel Dialogic D/240PCI-T1

The Dialogic D/240PCI-T1 voice card provides one T1 span with 24 channels of voice processing in a single PCI slot. The card connects directly to a channel-service unit, digital-service unit, or to other phone-network terminating equipment with the help of an RJ-48C connector.

If you install cards that have H.100 connectors, you need an H.100 cable that has at least as many connectors as you have cards (you must connect all cards with the use of a single cable) but no more than five extra connectors.

Figure A-7 represents D/240PCI-T1 top and side views.

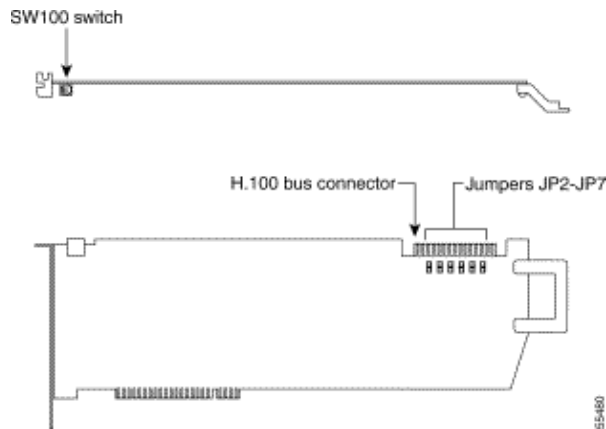
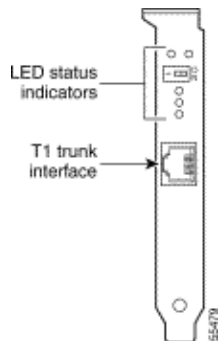
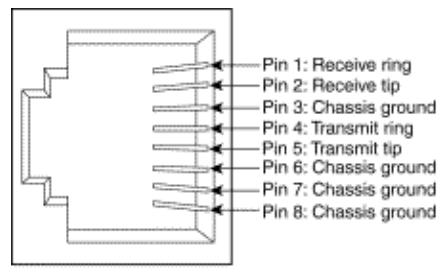

Figure A-8 represents D/240PCI-T1 connection pinouts and backplate.



Hardware Settings

Use this procedure in order to set switches and jumpers:

1. Set the rotary switch (SW100) to a unique value.

Each Intel Dialogic card with a rotary switch in the Cisco Unity server, regardless of model number, must have a unique value which starts with 1 and continues in sequence on subsequent cards. For example, set the rotary switch on the first three voice cards as shown in this figure. This is also the order in which you install the cards in the server.

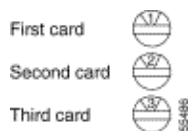

2. Settings for jumpers JP2 through JP5 depend on the number of D/240PCI–T1 voice cards in the Cisco Unity server.

One card	Set jumpers JP2 through JP5 to Off (Figure A–9) on the card.
Two cards	Set jumpers JP2 through JP5 to On (Figure A–10) on both cards.
Three or more cards	Set jumpers JP2 through JP5 to On (Figure A–10) on the first and last cards. Set jumpers JP2 through JP5 to Off (Figure A–9) on all the other cards.

Figure A–9 represents D/240PCI–T1 jumpers JP2 through JP5 in the Off position.

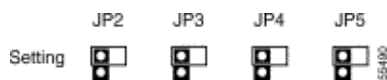
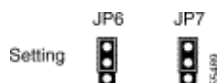

Figure A–10 represents D/240PCI–T1 jumpers JP2 through JP5 in the On position.



3. On jumpers JP6 and JP7, install shunts on the top two pins (1 and 2).



4. Return to Task 1: Step 4

NetPro Discussion Forums – Featured Conversations

Networking Professionals Connection is a forum for networking professionals to share questions, suggestions, and information about networking solutions, products, and technologies. The featured links are some of the most recent conversations available in this technology.

NetPro Discussion Forums – Featured Conversations for Voice
Service Providers: Voice over IP
Voice & Video: Voice over IP

Voice & Video: IP Telephony
Voice & Video: IP Phone Services for End Users
Voice & Video: Unified Communications
Voice & Video: IP Phone Services for Developers
Voice & Video: General

Related Information

- **Voice Technology Support**
- **Voice and Unified Communications Product Support**
- **Recommended Reading: Troubleshooting Cisco IP Telephony**
- **Technical Support & Documentation – Cisco Systems**

All contents are Copyright © 2006–2007 Cisco Systems, Inc. All rights reserved. Important Notices and Privacy Statement.

Updated: Feb 02, 2006

Document ID: 44328
