

Installation and Configuration Guide for the Sprint Network Interface Controller

[TAC Notice: What's Changing on TAC Web](#)

Contents

- [Introduction](#)**
- [Prerequisites](#)**
 - [Requirements](#)
 - [Components Used](#)
 - [Conventions](#)
- [Relationship to ICM System](#)**
 - [ICM Network](#)
- [Relationship to the Sprint Network](#)**
 - [Communications Link](#)
- [Hardware Setup](#)**
 - [Base Configuration](#)
 - [Eicon DPNA Card Installation](#)
 - [Eicon DPNA Card Configuration](#)
- [Software Setup](#)**
 - [Sprint NIC Application Software](#)
- [Final Test Prior to Customer Delivery](#)**
 - [Router Connectivity Test](#)
 - [SCP Simulator Test](#)
- [Field Installation Steps](#)**
 - [Verify Router Connectivity](#)
 - [Connect the X.25 Links](#)
 - [Sprint Link Verification Test](#)
- [Eiconcard Connection for Windows NT 4.0 Server Software Installation](#)**
- [NetPro Discussion Forums - Featured Conversations](#)**
- [Related Information](#)**

Help us help you.

Please rate this document.

Excellent
 Good
 Average
 Fair
 Poor

This document solved my problem.

Yes
 No
 Just browsing

Suggestions for improvement:

(256 character limit)

Introduction

This document describes the procedures for installation and configuration of the Sprint Network Interface Controller (NIC) as part of a customer system. The Sprint NIC is part of the Cisco Unified Intelligent Contact Management (ICM) Enterprise Central Controller installation.

Prerequisites

Requirements

Cisco recommends that you have knowledge of these topics:

- ICM Central Controller installation
- Microsoft Windows NT/Windows 2000 hardware and software installation

Components Used

The information in this document is based on these software and hardware versions:

- All ICM versions
- Windows NT/Windows 2000

The information in this document was created from the devices in a specific lab environment. All of the devices used in this document started with a cleared (default) configuration. If your network is live, make sure that you understand the potential impact of any command.

Conventions

Refer to [Cisco Technical Tips Conventions](#) for more information on document conventions.

Relationship to ICM System

ICM Network

The Sprint NIC runs one process on each side of the Central Controller. The Sprint NIC communicates with the colocated router process by the ICM standard Message Delivery System (MDS) interface. Each of the Sprint NIC processes operates without knowledge of the other. Both Sprint NIC processes can simultaneously process route inquiries from the Sprint network.

Relationship to the Sprint Network

The Sprint Intelligent Network Service Delivery system enables the connection of an external customer Routing Processor (SiteRP) to the Sprint network by the Sprint Service Control Points (SCPs). In this model, ICM functions as a SiteRP. The Sprint NIC, however, performs all of the SiteRP-specific processing.

Communications Link

There are up to five SCPs in the Sprint network. In a duplexed ICM environment, each NIC connects to the Sprint network by five 56-kbps point-to-point communication links. There is one for each SCP that is provisioned on the Sprint Fibernet network. Each NIC contains three Eicon Technology Dual-Port Network Adapter/PC (DPNA) cards. The two ports on a DPNA card are designated as port 1 and port 2. Port 1 is the port that is closest to the top edge of the card. Port 2 is the port that is closest to the PC connector edge of the card.

Five of the six DPNA ports are used to connect to the SCPs. The remaining DPNA port is not used and is disabled. Cisco supplies five 9-foot cables. Each connects from a DPNA port to a Sprint TP7 device with the use of a V.35 interface. The cable has a male DB-26 connector to the DPNA card and a standard male 34-pin V.35 connector to the TP7 device. Alternatively, you can use one channel bank device in the place of the five TP7 devices in order to connect the Sprint NIC to the

SCPs.

The communications links are routed to the SCPs in the network. [Figure 1](#) shows this configuration.

Figure 1: Sprint NIC Configuration in a Duplexed ICM Network

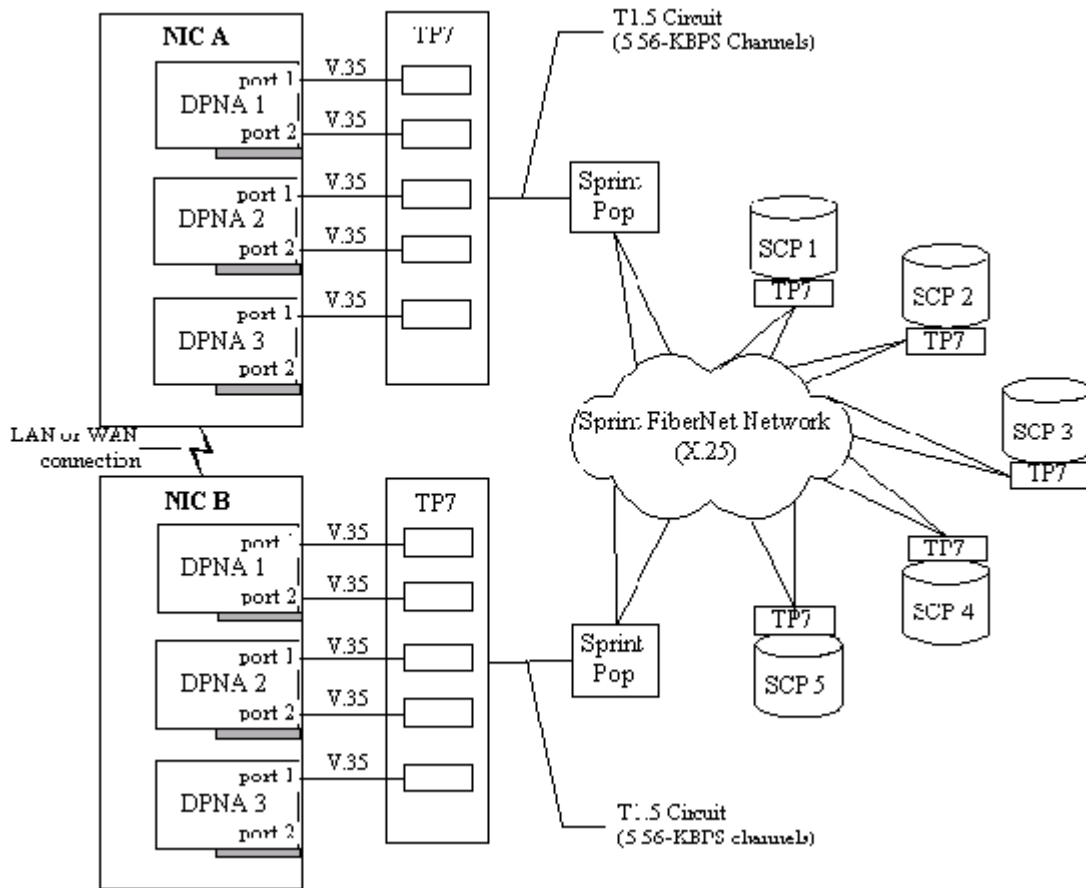

In a simplexed ICM configuration, connect the Sprint NIC to the five SCPs by redundant links.

Note: Simplexed links in a simplexed configuration also can be supported.

In the configuration in this section, the NIC contains five DPNA cards. Each of two DPNA ports connects each NIC to each Sprint SCP. The physical connections in the simplexed configuration are the same as the connections for the duplexed configuration.

Hardware Setup

The hardware setup is the first stage of the Sprint NIC/Central Controller installation and configuration. Refer to the [Cisco ICM Software Configuration Guide](#) (Version 5.0) for a general description of the ICM Central Controller hardware setup. A hardware setup that is specific to the Sprint NIC requires these steps:

1. Install three Eicon DPNA cards.

Note: Install five DPNA cards in a simplexed ICM environment.

2. Configure the DPNA cards.

3. Reboot the system.
4. Verify the operation of the new configuration.

Base Configuration

The Sprint NIC/Central Controller hardware platform is a multiprocessor Intel Pentium PC that runs a Windows 2000 Server. In addition to the base Central Controller configuration, three 3.5V Peripheral Component Interconnect (PCI) expansion 64-bit slots are necessary for the NIC in a duplexed ICM configuration. Five expansion slots are necessary for the NIC in a simplexed ICM configuration.

Note: You can also install the Eicon DPNA PCI cards that the Sprint NIC uses on systems that run a Windows NT 4.0 Server. However, Cisco does not recommend this installation.

Eicon DPNA Card Installation

The Sprint NIC requires the installation of three Eicon DPNA cards and configuration of the cards for the X.25 protocol. In a simplexed ICM environment, the NIC requires five DPNA cards. The DPNA/PC board is a 3.5V PCI S-Series adapter. Each adapter contains two high-speed V.35 interface ports, each capable of data rates of up to 200 kbps. Five V.35 High-Speed Interface (HSI) modem cables are necessary for each NIC. In a simplexed ICM environment, 10 cables are necessary.

Complete these steps:

1. Insert the DPNA cards into the available 64-bit PCI slots.
2. Install the Eiconcard Connections for Windows 2000/Windows XP S-Series software.

You must install the Eiconcard Connections software on the Central Controller PC in order to complete the DPNA cards and device-driver installation.

- a. After installation of the DPNA cards on the Central Controller, restart the machine and log on as administrator or an equivalent.

Windows 2000 detects new hardware and starts the Found New Hardware Wizard.

- b. Insert the Eicon Universal Connections Suite CD into the Central Controller CD-ROM drive.
- c. Follow the Wizard and choose **Search for a suitable driver for my device**.
- d. Select the CD-ROM drive to search and clear all other options.
- e. Click **Next** and follow the instructions.
- f. After you restart Windows, update the Eicon drivers.

[Figure 2](#) displays all the files under Z:\Windows\W2K-XP\Connections for Windows 2000-XP. Run ECUPDATE.EXE in order to update all the Eicon drivers to the latest version.

Note: "Z:" corresponds to the drive letter of your CD-ROM.

Figure 2: ECUPDATE.EXE

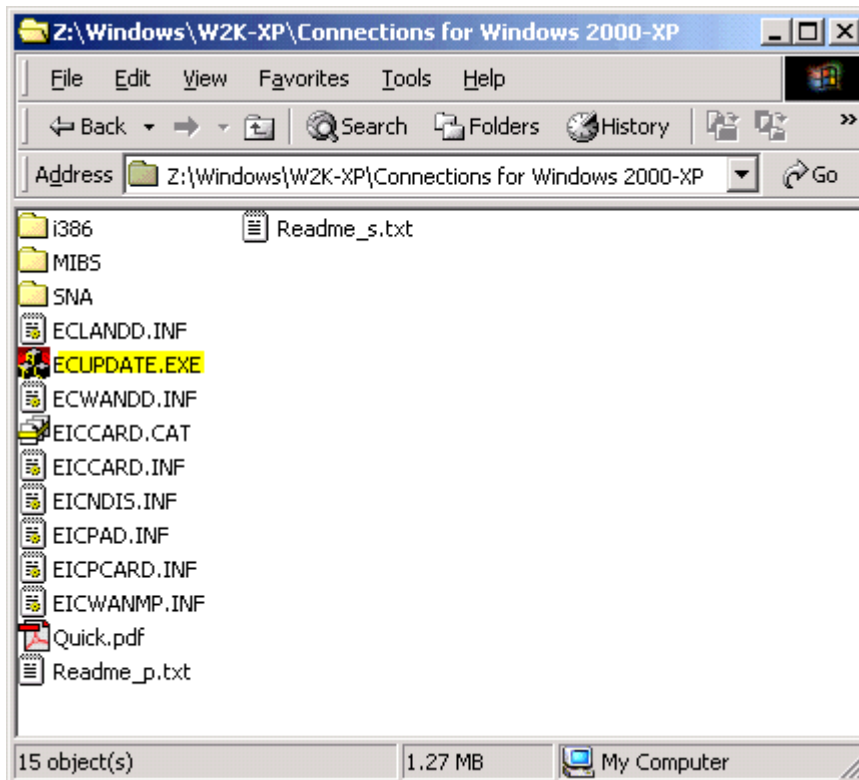

3. Use Device Manager in order to verify the recognition of all cards in the system.

Complete these steps:

- a. Right-click **My Computer**.
- b. Choose **Manage**.
- c. Choose **Device Manager**.
- d. Expand **Network Adapters**.

Eicon DPNA Card Configuration

After installation of the Eiconcard Connections software, you must configure each card. Follow the Eicon standard instructions for configuration of the cards. Choose **Start > Eicon Configuration Program** in order to locate these instructions.

Complete these steps in order to configure the DPNA card hardware parameters:

1. Configure the PCI hardware.
 - o The Eicon Configuration Program assigns the card number.
 - o In the five-link configuration for a duplexed ICM environment, configure only the first port on card 3.

- o The example in [Figure 3](#) uses only one Eicon DPNA card. MTLTR-DL380A represents the host machine.

Figure 3: Eiconcard Hardware Settings

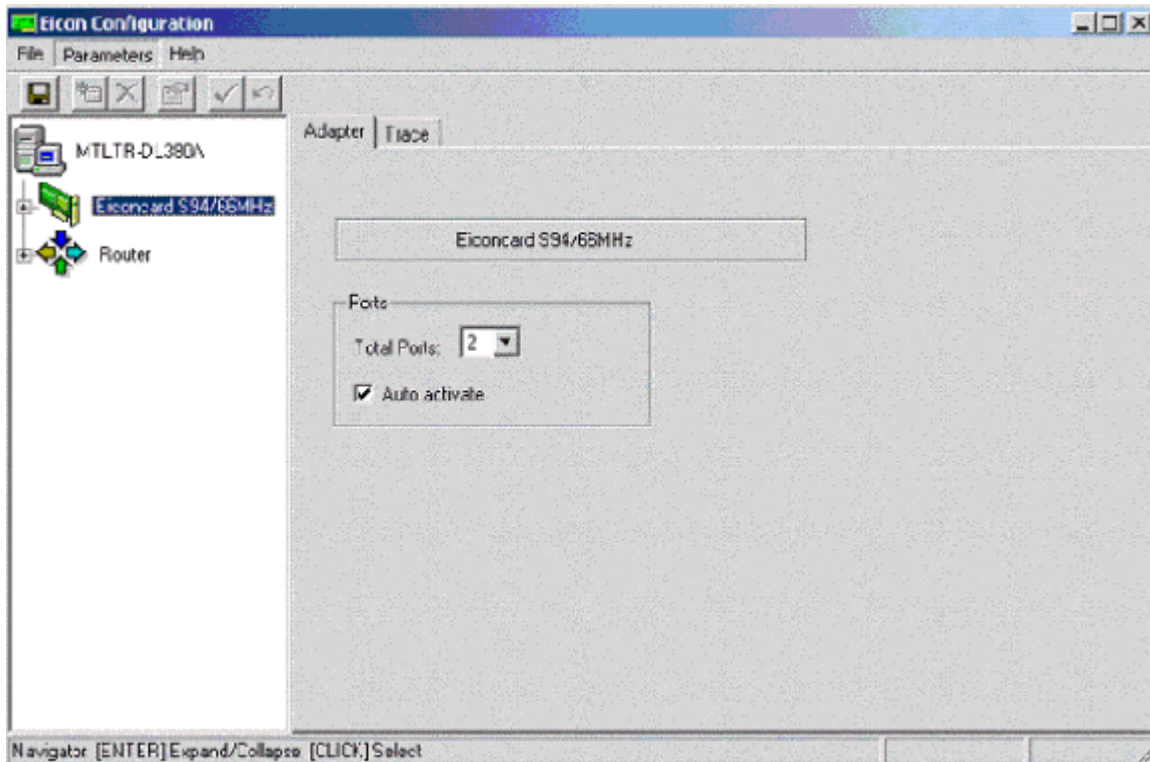

2. Configure each port on the Eicon DPNA card.

[Figure 4](#) shows this configuration.

Note: The configured ports have sequential numbers, which start with 1. For example, if there are five Eicon DPNA cards with two ports each, the ports have the numbers 1 through 10.

Figure 4: Eiconcard Port Configuration

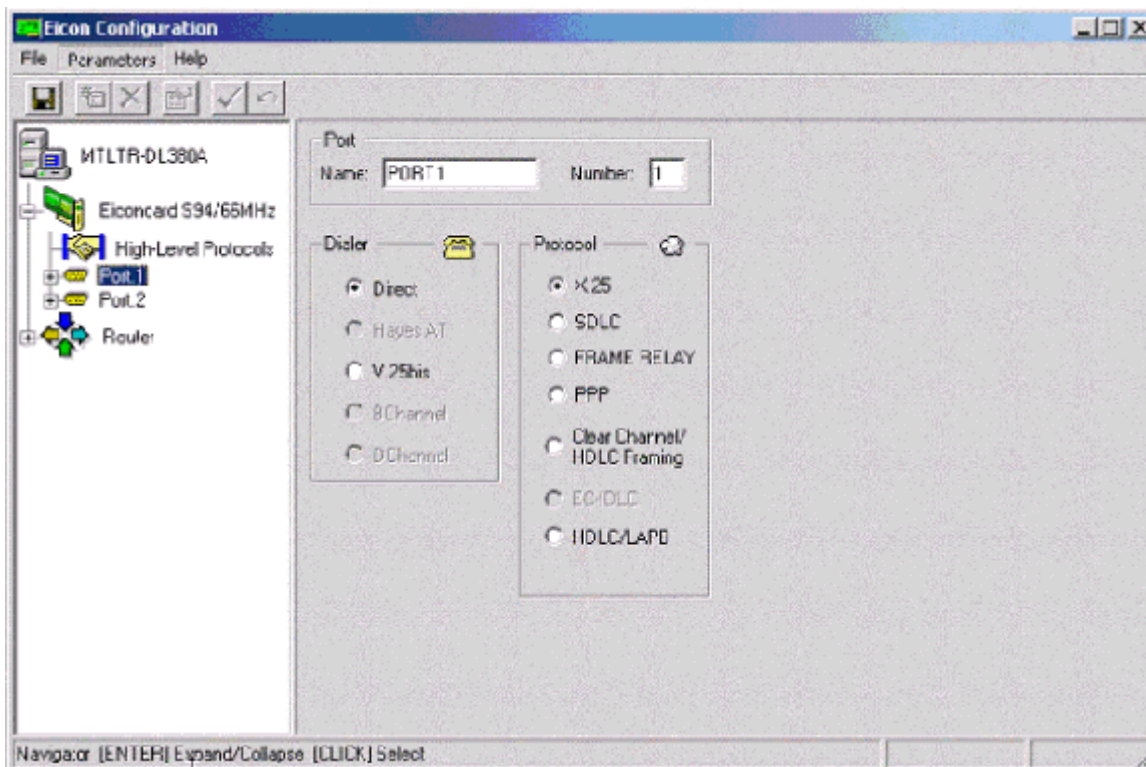

- Configure the X.25 packet-level protocol General for each port.

Figure 5 shows this configuration.

Figure 5: X.25 Packet-Level Protocol—General Configuration

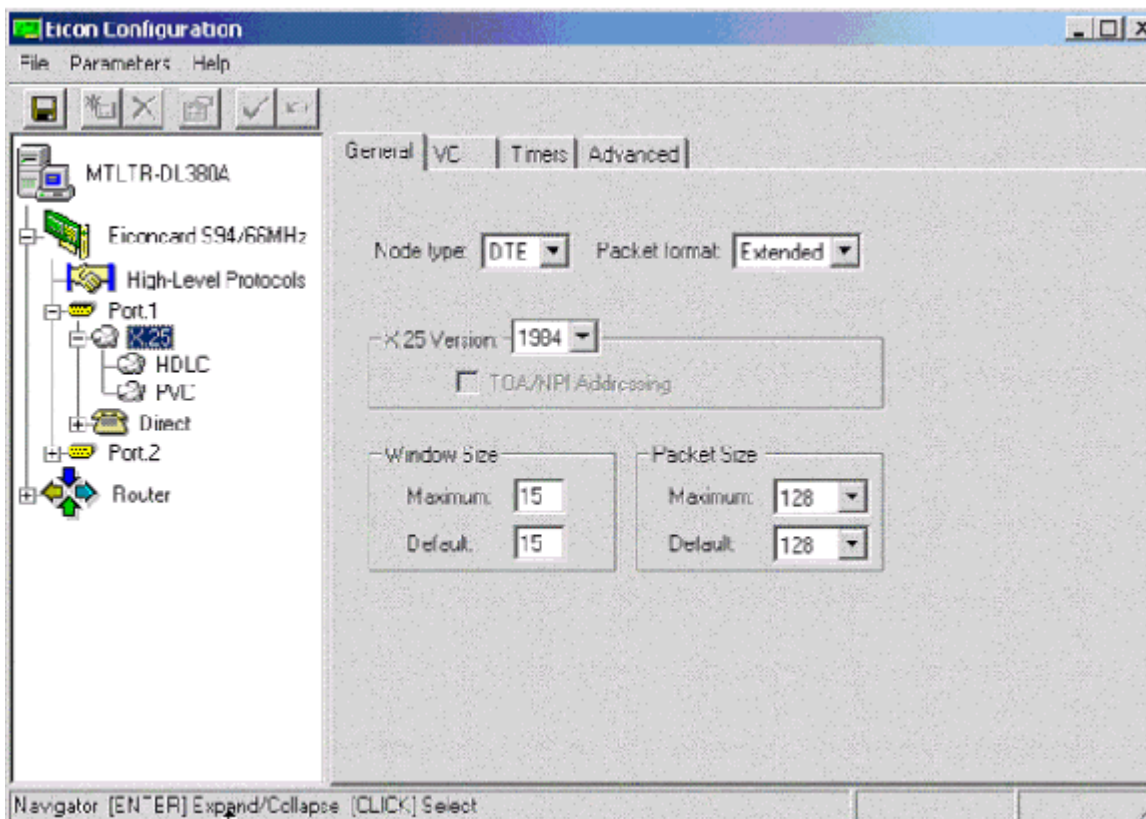

- Configure the X.25 packet-level protocol VC for each port.

[Figure 6](#) shows this configuration.

Figure 6: X.25 Packet-Level Protocol—VC Configuration

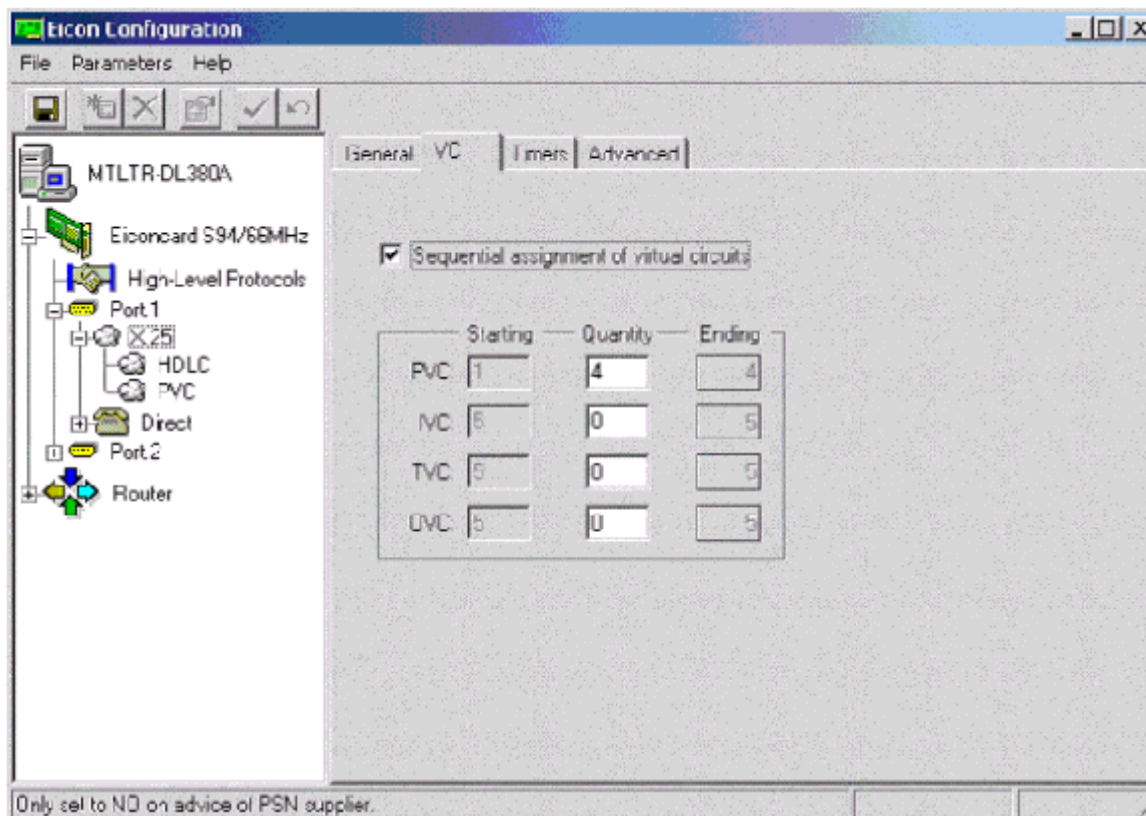

5. Configure the X.25 packet-level protocol Timers for each port.

[Figure 7](#) shows this configuration.

Figure 7: X.25 Packet-Level Protocol—Timers Configuration

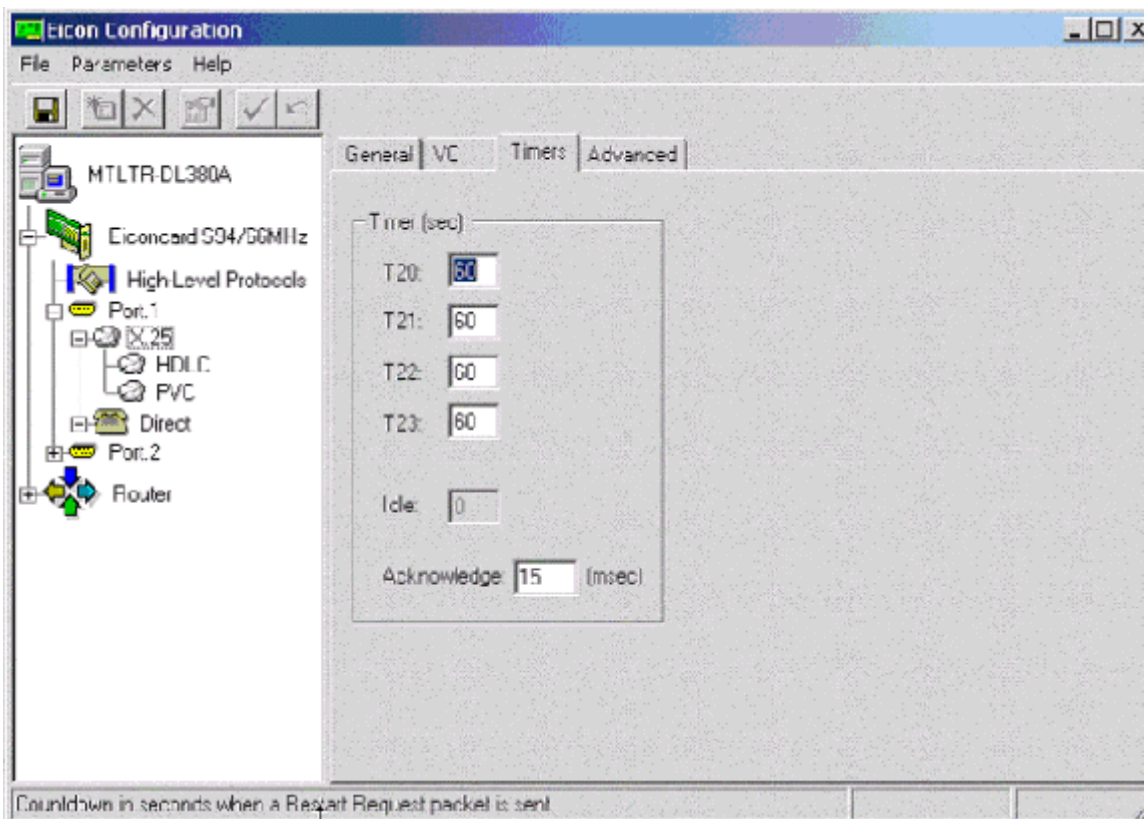

6. Configure the X.25 packet-level protocol Advanced for each port.

Figure 8 shows this configuration.

Figure 8: X.25 Packet-Level Protocol—Advanced Configuration

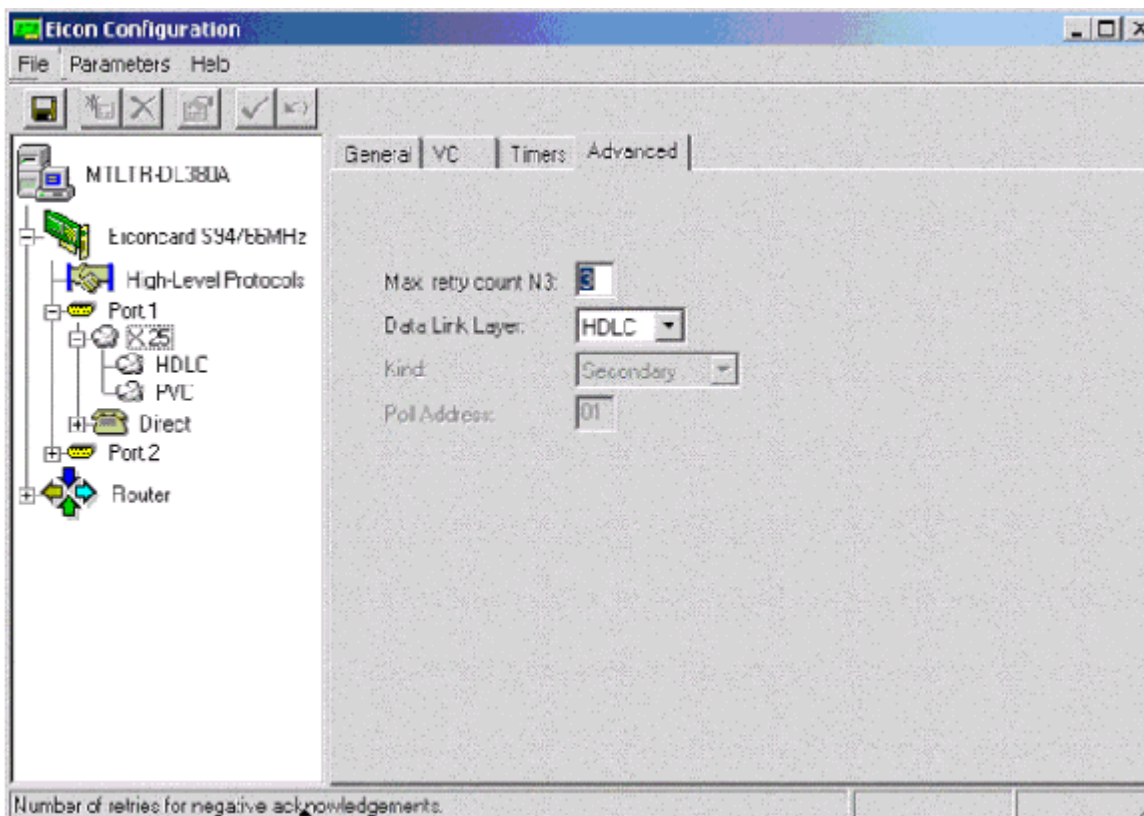

7. Configure the High-Level Data Link Control (HDLC) protocol General for each port.

[Figure 9](#) shows this configuration.

Figure 9: HDLC Protocol—General Configuration

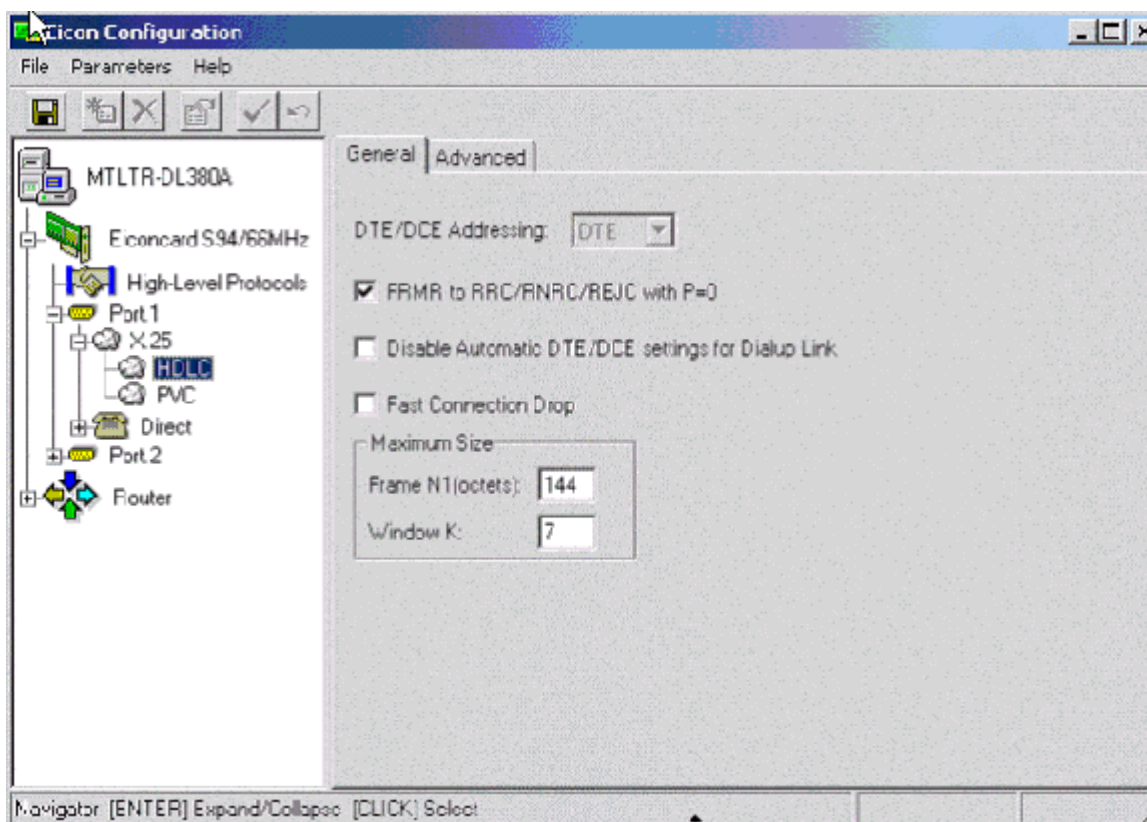

8. Configure the HDLC protocol Advanced for each port.

[Figure 10](#) shows this configuration.

Figure 10: HDLC Protocol—Advanced Configuration

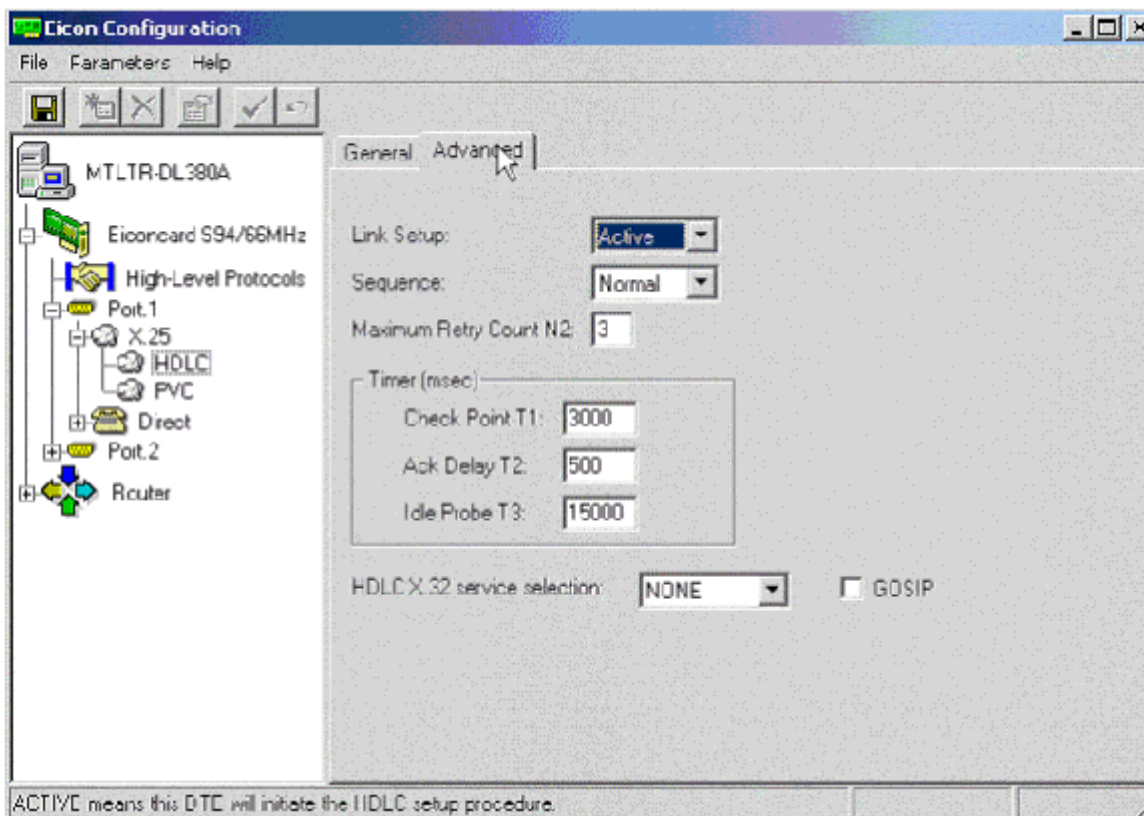

9. Verify the Permanent Virtual Circuit (PVC) configurations.

Figure 11 shows this verification.

Figure 11: PVC Configuration

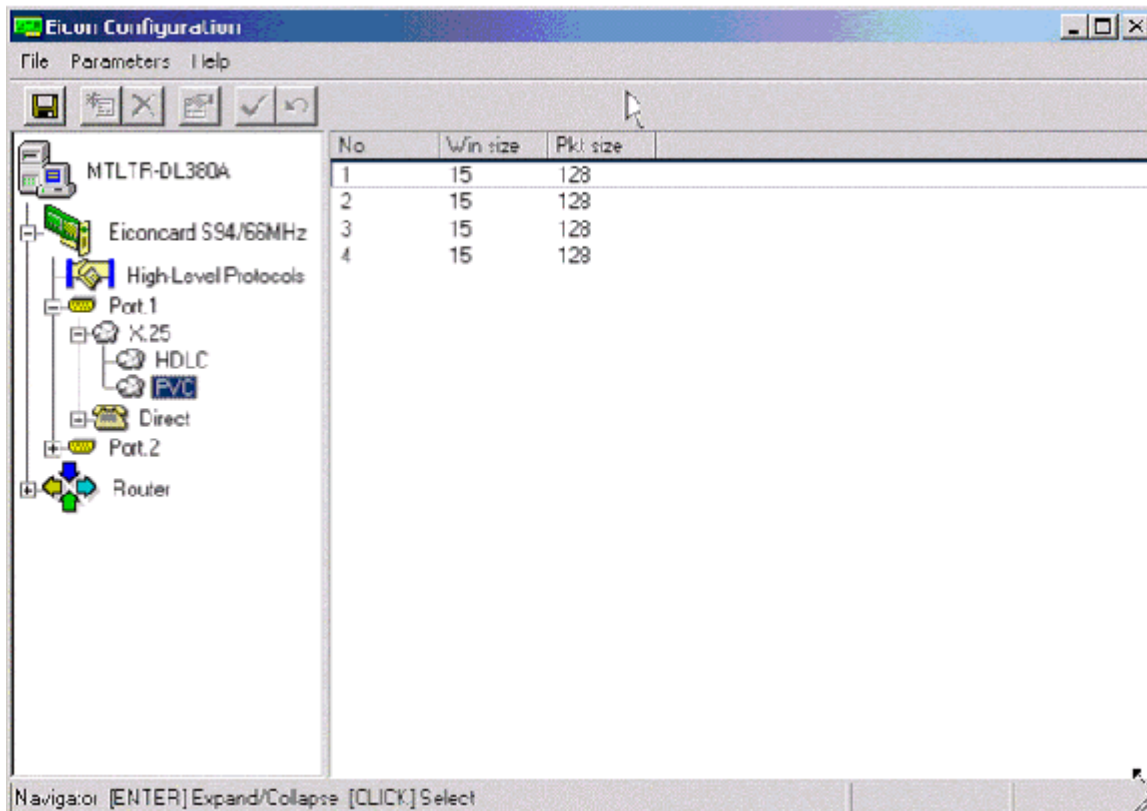

- Configure the direct dialer and the sync driver parameters.

[Figure 12](#) shows this configuration.

Note: No configuration changes are necessary for the direct dialer parameters.

Figure 12: Sync Driver Configuration

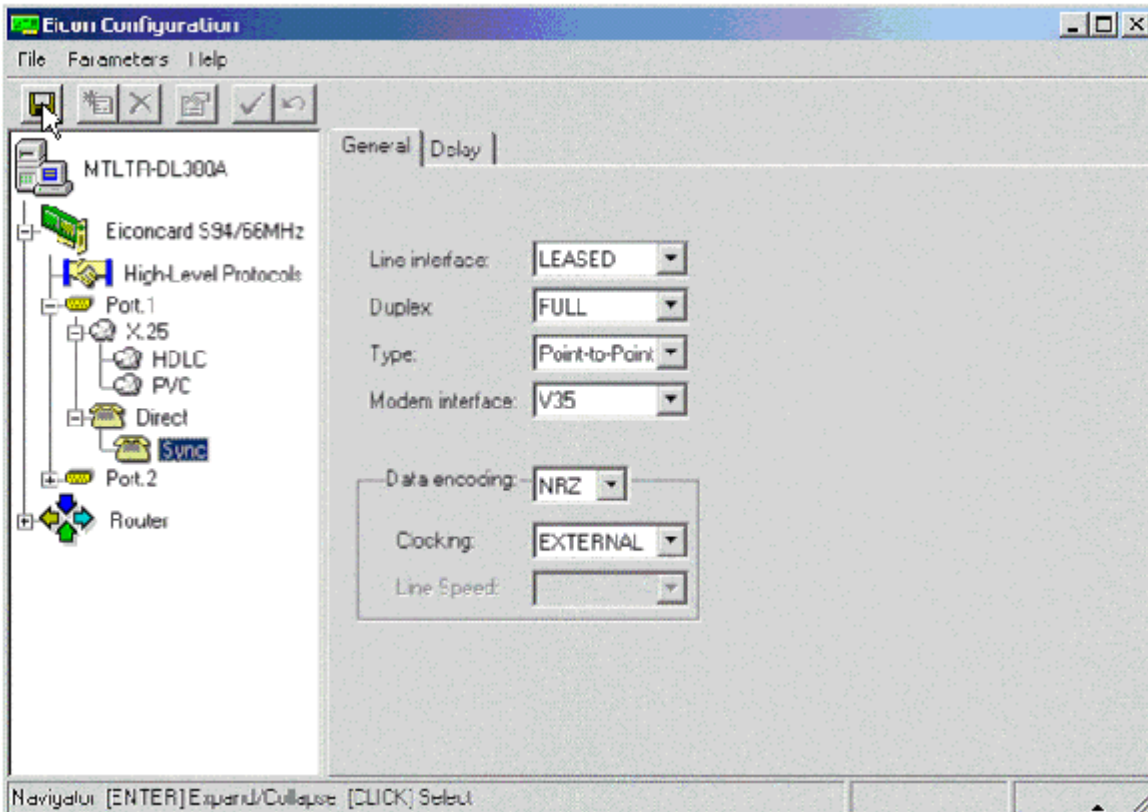

After you have configured all Eicon DPNA cards, a prompt to restart the system displays.

Software Setup

The ICM software setup is the second stage of the NIC installation and configuration. Complete these steps for the software setup:

- Install the Sprint NIC application as part of the ICM Central Controller software installation.
- Configure the NIC application.

Sprint NIC Application Software

Installation

The Sprint NIC software installation takes place as part of the standard ICM Central Controller (router) installation. Refer to the [Cisco ICM Software Configuration Guide](#) (Version 5.0) for details on how to install the ICM Central Controller software.

Configuration

The Sprint NIC application-level configuration is maintained in the Windows registry. Use the Windows registry editor in order to modify the NIC configuration parameters. The registry key entry for the NIC is:

```
\HKEY_LOCAL_MACHINE\SOFTWARE\Cisco Systems, Inc.\ICM\cust_inst\RouterSide\
  SPRNIC\CurrentVersion
```

Note: The *cust_inst* indicates the customer instances, and *RouterSide* is either RouterA or RouterB.

There are three subkeys in the Sprint NIC registry key entry:

- \SPRNIC\CurrentVersion\Commands
- \SPRNIC\CurrentVersion\RCEngine
- \SPRNIC\CurrentVersion\SPRComm

Before you begin the Sprint NIC application-level configuration, you must have knowledge of:

- The NIC physical controller ID that you assign to the NIC with Configure ICM

You can set this PhysicalControllerID parameter in the NIC RCEngine subkey entry.

- The number of Sprint SCPs that will connect to the NIC

You can set this NumSCPs parameter in the NIC SPRComm subkey entry. The default is 5. Do not change the default.

- The number of links the NIC uses to connect to each SCP

You can set this NumLinksPerSCP parameter in the NIC SPRComm subkey entry. The default is 1 for a duplexed ICM configuration. If the ICM configuration is simplex and you want to use redundant links to connect the NIC to each SCP, set the NumLinksPerSCP value to 2. The NIC in a simplex ICM configuration can connect to each SCP by simplex links. In this case, set the NumLinksPerSCP value to 1.

Note: Cisco does not recommend this simplex-links configuration.

- The SCP ID for each SCP that will connect to the NIC

You must obtain this information from Sprint. You can set this SCPn_ID parameter in the NIC SPRComm subkey entry. Each SCPn_ID corresponds to a DPNA card port number. For instance, SCP1_ID identifies the SCP that connects to port 1 on Eiconcard 1. The default SCP IDs have been preconfigured in the NIC SPRComm subkey entry. Be sure to verify that the physical connections from the Eiconcard ports to the SCPs agree with the configured SCP IDs in the SPRComm registry subkey entry.

- The number of PVCs that will be used for each X.25 link

You can set this SCPnMaxPVCs parameter in the NIC SPRComm subkey entry. The default is 4. Do not change the default.

- The version of the Inquiry Message, with or without Feature Indicator, that will be used for each SCP

Sprint specifies this information at the time of provision of the links. You can set this

SCPnUseFeatureInd parameter in the NIC SPRComm subkey entry. Currently, the only Inquiry Message version that Sprint supports is the version without Feature Indicator. The default SCPnUseFeatureInd value is 0. Do not change the default.

Final Test Prior to Customer Delivery

Router Connectivity Test

Start the ICM Node Manager Services in order to test the NIC installation and configuration. After you start the ICM Node Manager Services, the NIC command window displays the information in [Figure 13](#).

Figure 13: Sprint NIC Process

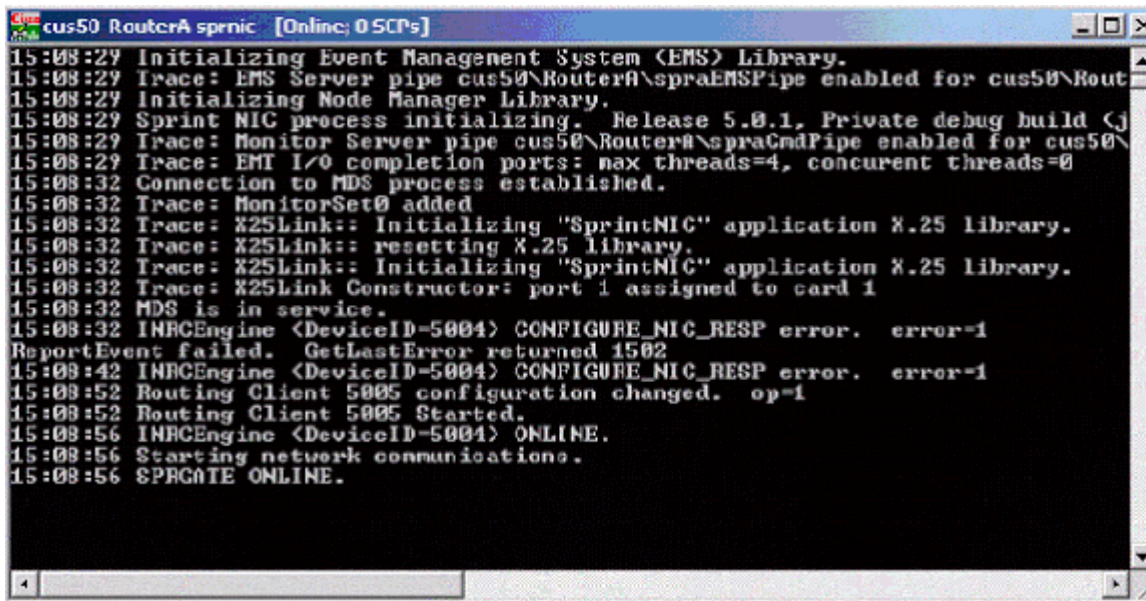

```

cus50 RouterA sprnic [Online; 0 SCP's]
15:08:29 Initializing Event Management System (EMS) Library.
15:08:29 Trace: EMS Server pipe cus50\RouterA\spraEMSPipe enabled for cus50\RouterA
15:08:29 Initializing Node Manager Library.
15:08:29 Sprint NIC process initializing. Release 5.0.1, Private debug build (Cj
15:08:29 Trace: Monitor Server pipe cus50\RouterA\spraCmdPipe enabled for cus50\
15:08:29 Trace: EMT I/O completion ports: max threads=4, concurrent threads=0
15:08:32 Connection to MDS process established.
15:08:32 Trace: MonitorSet0 added
15:08:32 Trace: X25Link:: Initializing "SprintNIC" application X.25 library.
15:08:32 Trace: X25Link:: resetting X.25 library.
15:08:32 Trace: X25Link:: Initializing "SprintNIC" application X.25 library.
15:08:32 Trace: X25Link Constructor: port 1 assigned to card 1
15:08:32 MDS is in service.
15:08:32 INRCEngine <DeviceID=5004> CONFIGURE_NIC_RESP error. error=1
ReportEvent failed. GetLastError returned 1502
15:08:42 INRCEngine <DeviceID=5004> CONFIGURE_NIC_RESP error. error=1
15:08:52 Routing Client 5005 configuration changed. op=1
15:08:52 Routing Client 5005 Started.
15:08:56 INRCEngine <DeviceID=5004> ONLINE.
15:08:56 Starting network communications.
15:08:56 SPRGATE ONLINE.
  
```

Note: This example shows information for one card, one port, and one SCP.

SCP Simulator Test

The Router Connectivity Test does not test the X.25 links and does not drive X.25 network traffic through the NIC and the router. You can perform additional tests with the use of an SCP simulator. [Figure 14](#) shows the setup.

Figure 14: NIC Simulation Setup

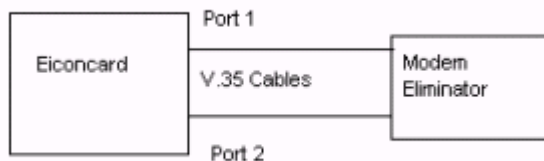

Note: This simulator has been set up to run the SCP simulator with the NIC over one Eiconcard.

The SCP simulator is similar to the NIC. The SCP simulator runs on the same platform and uses

most of the same X.25 software components as the NIC. The SCP simulator can have up to 10 X.25 links and five Eiconcards. The links connect to each of the five NIC links with either of these cables:

- V.24/V.35 HSI null-modem cables, part number 300-031, which Eicon Technology manufactures
- Regular V.35 cables that attach to a modem eliminator, which provides V.35 clocking

Complete these additional configuration steps in order to use the SCP simulator:

1. Define the registry subkey entry for the SCP simulator under HKEY_LOCAL_MACHINE\SOFTWARE\Cisco Systems, Inc.\.
2. Create the SCPSIM subkey default values that [Figure 15](#) displays.

Figure 15: SCPSIM Subkey Default Value

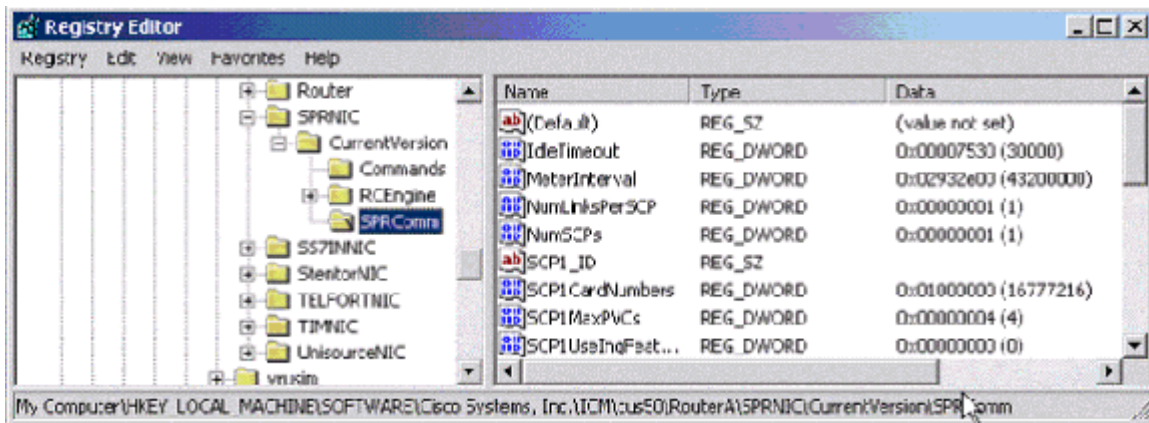

3. Create the SCPSIM Parameters subkey default values that [Figure 16](#) displays.

Figure 16: SCPSIM Parameters Subkey Default Value

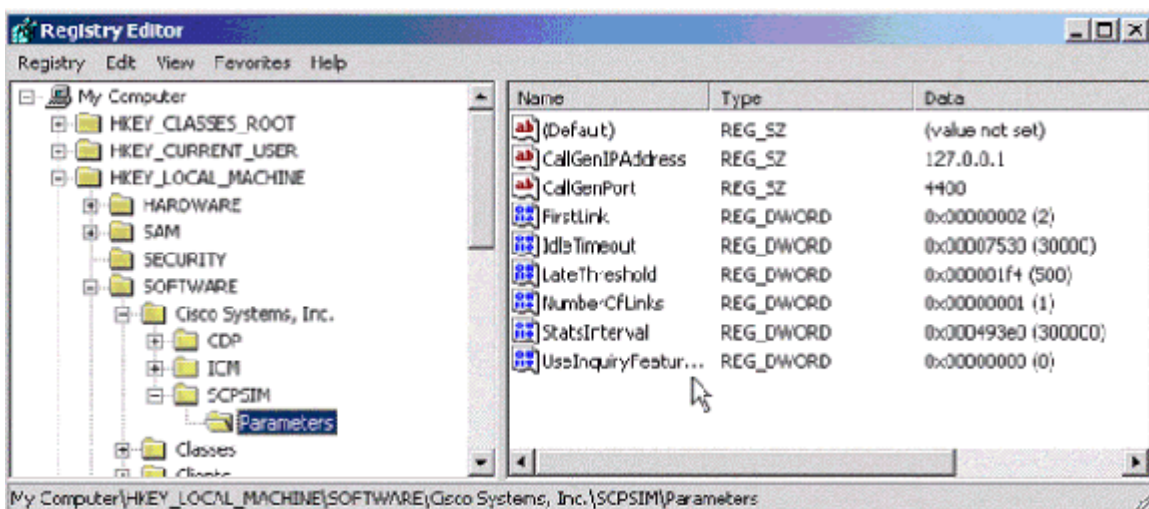

4. Set the Eiconcard ports that the SCPSIM uses to a DCE Node Type.
5. Create and install a router test script with use of the ICM Script Editor.

Create the test script on the customer system that is designed to work with the route requests and route responses that the SCP simulator will generate. [Figure 17](#) shows an example test script.

Figure 17: Example Test Script for the Sprint NIC Simulation

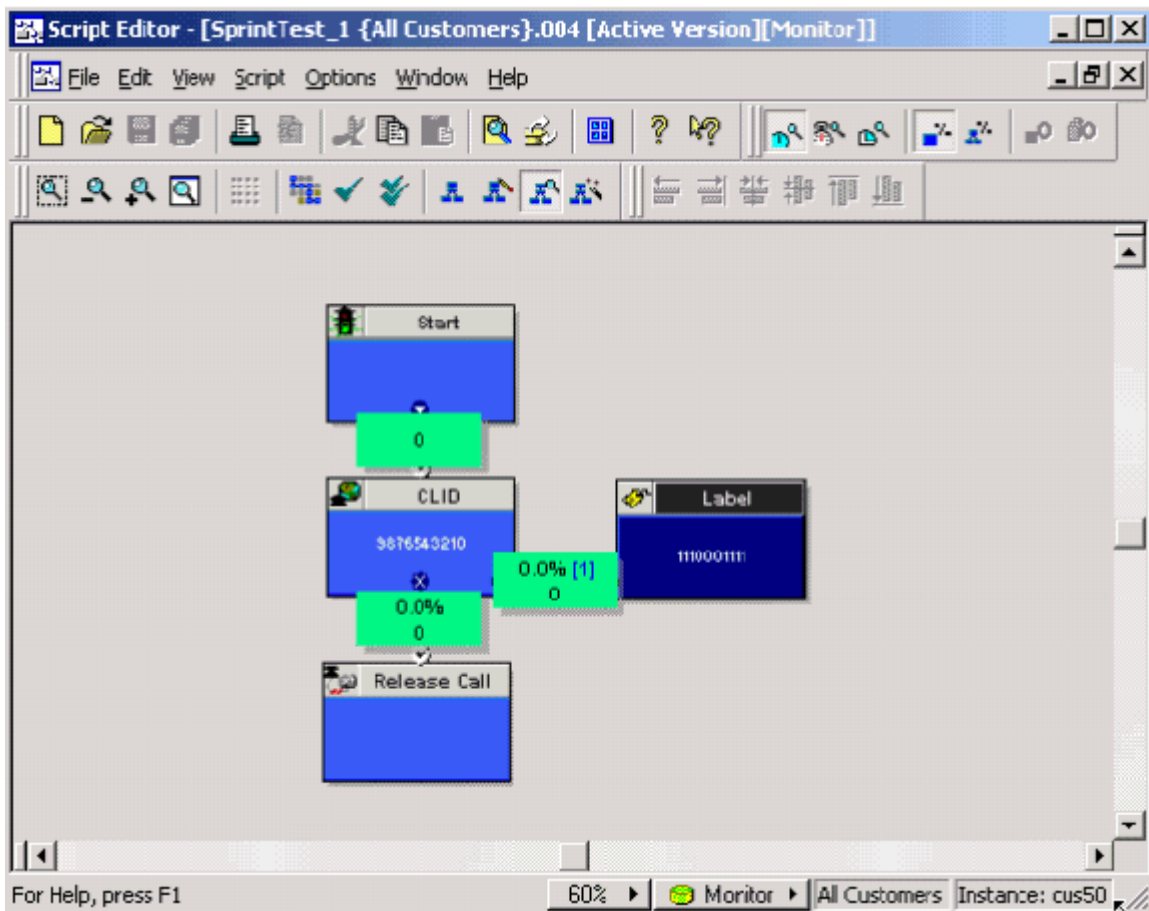

Note: You need this script initially for SCP simulator tests and perhaps for the Sprint protocol verification test as well. See the [Sprint Link Verification Test](#) section.

After you complete these configuration steps, you can run a test with use of the SCP simulator, the NIC, and the router.

1. Ensure that the ICM Central Controller Node Manager Services run.
2. Start the SCP simulator and call generator (CallGen).

Traffic now flows from the SCP simulator to the NIC to the router, and back again in the reverse order. You can monitor progress of the test in these ways:

- Check the SCP simulator for performance statistics. The SCP simulator reports the statistics on the main screen every 5 minutes. The time interval can differ, which depends on how you have set the StatsInterval parameter in the SCPSIM registry subkey.
- Use the script monitor feature from the Administrative Workstation (AW).
- Watch the main screen on the NIC and the SCP simulator. [Figure 18](#) shows the NIC, and [Figure 19](#) shows the SCP simulator.

Figure 18: NIC Process

```

cus50-RouterA sprnic - [Online; 1 SCP]
14:53:22 Initializing Event Management System (EMS) Library.
14:53:22 Trace: EMS Server pipe cus50\RouterA\spraEMSPipe enabled for cus50\RouterA
14:53:22 Initializing Node Manager Library.
14:53:22 Sprint NIC process initializing. Release 5.0.1, Private debug build (j
14:53:22 Trace: Monitor Server pipe cus50\RouterA\spraCndPipe enabled for cus50\
14:53:22 Trace: EMT I/O completion ports: max threads=4, concurrent threads=0
14:53:23 Connection to MDS process established.
14:53:23 Trace: MonitorSet0 added
14:53:24 Trace: X25Link:: Initializing "SprintNIC" application X.25 library.
14:53:24 Trace: X25Link:: resetting X.25 library.
14:53:24 Trace: X25Link:: Initializing "SprintNIC" application X.25 library.
14:53:24 Trace: X25Link Constructor: port 1 assigned to card 1
14:53:24 MDS is in service.
14:53:24 INRC Engine (DeviceID=5004) CONFIGURE_NIC_RESP error. error=1
ReportEvent failed. GetLastError returned 1502
14:53:34 INRC Engine (DeviceID=5004) CONFIGURE_NIC_RESP error. error=1
14:53:44 Routing Client 5005 configuration changed. op=1
14:53:44 Routing Client 5005 Started.
14:53:47 INRC Engine (DeviceID=5004) ONLINE.
14:53:47 Starting network communications.
14:53:47 SPRGATE ONLINE.
14:53:47 SPRCOMM Link 1 to SCP OPEN.

```

Figure 19: SCP Simulator Process

```

C:\WINNT\System32\cmd.exe - srpsim
shutdown link 2
D:\nic\SprintSCPSim>scpsim
15:37:13 Trace: X25Link:: Initializing "SCPSIM" application X.25 library.
15:37:13 Trace: X25Link:: resetting X.25 library.
15:37:13 Trace: X25Link:: Initializing "SCPSIM" application X.25 library.
15:37:14 Trace: X25Link Constructor: port 2 assigned to card 1
15:37:14 Trace: Beginning InputDriver on link 2, channel 2.
15:37:14 Trace: Beginning OutputDriver on link 2, channel 1.
15:37:14 Trace: Connection 12,01 in OPENING state.
15:37:14 Trace: Connection 12,21 in ACTIVE state.
15:37:14 Trace: Beginning InputDriver on link 2, channel 4.
15:37:14 Trace: Beginning OutputDriver on link 2, channel 3.
15:37:14 Trace: Connection 12,11 in OPENING state.
15:37:14 Trace: Connection 12,41 in ACTIVE state.
15:37:14 Trace: Link 2 in OPEN state.
scpsim: 15:37:14 Trace: EMT I/O completion ports: max threads=4, concurrent threads=0
CallGenListener: CallGen connection established.
15:37:44 Trace: Connection 12,21 in ACTIVE state.
15:37:45 Trace: Connection 12,41 in TIMEOUT state.
15:37:45 Trace: Connection 12,41 in ACTIVE state.
15:38:14 Trace: Connection 12,21 in ACTIVE state.
15:38:15 Trace: Connection 12,41 in ACTIVE state.

```

Field Installation Steps

Verify Router Connectivity

Start the Sprint NIC as part of the Central Controller Node Manager Services at the customer site. After the router receives the system configuration from the Logger, the NIC passes the router connectivity test. See the [Router Connectivity Test](#) section.

Connect the X.25 Links

Cisco provides five 9-foot V.35 HSI modem cables. You must connect the V.35 cables from the NIC DPNA cards to the TP7 devices. The [Communications Link](#) section describes this connection.

1. Label each cable at the 34-pin V.35 connector end.

The label must indicate the link number, SCP location, and Sprint Fiber Net circuit number.

Note: Obtain the Sprint Fiber Net circuit number from Sprint in advance.

For example, the label for the link 1 cable at Sprint reads “LINK 1, Burlingame SCP, Sprint Fiber Net 98/2:7:4, Circuit #95XHGS441408”.

2. Connect the DB-26 end of the link 1 cable to port 1 of DPNA card 1.
3. Connect the DB-26 end of the link 2 cable to port 2 of Eiconcard 1.
4. Connect the link 3 cable to port 1 of Eiconcard 2.

Continue this process until you have connected all five links. Connect all 10 links in a simplex configuration.

5. Connect the cables to the TP7 devices or the single channel bank device.

If the NIC location is more than 10 feet from the TP7 devices, your responsibility is to provide the additional V.35 cabling that is necessary.

Note: Be aware of this responsibility well in advance of the installation.

The Sprint Fiber Net links can be live or not live at the time of installation. Even if the Fiber Net links are live at this time and able to go in service, the links do not carry any traffic. Sprint may enable the traffic flow only after the link verification test. In some cases, the TP7 devices are not in place at the time of the NIC installation. In this situation, speak with the customer datacomm technician. Show the cables to the datacomm technician and explain the labels in order to enable connection of the cables later.

Sprint Link Verification Test

Sprint can require you to perform a protocol verification test before traffic flows onto the links. The test is not part of the installation process and you cannot complete the test at the time of installation. However, during the installation, you must fulfill these prerequisites in order to run the test:

- Installation and configuration of the NIC and Central Controller
- Connection of the NIC to the TP7 or channel bank

Note: You can perform this connection later.

- Availability on the Central Controller of the test script to perform the routing test

Note: Normally, this script is checked in advance during SCP simulator tests. Sprint needs to know the dialed numbers for the test and the labels that are returned in the route responses.

Note: For the link verification test, the Peripheral Gateway (PG) does not need to communicate with the Central Controller.

Eiconcard Connection for Windows NT 4.0 Server Software Installation

Some earlier ICM systems can require you to install the Sprint NIC on a hardware platform that runs a Windows NT 4.0 Server. Although the port configuration and ICM configurations are basically the same, the Eiconcard driver installation differs.

Note: Refer to [Figure 4](#) for the Eiconcard port configuration.

Complete these steps in order to install on a Windows NT 4.0 Server:

1. Insert the DPNA cards into the available 3.5V 64-bit PCI slots.
2. Insert the Eicon Universal Connections Suite CD into the CD-ROM drive.
3. Choose **Start > Control Panel**.
4. Double-click **Network**.
5. Click the **Adapter** tab.
6. Click **Add**.

The Select Network Adapter window displays.

7. Choose **Eicon WAN Adapters** and click **OK**.
8. At the prompt to enter the path, enter **d:\windows\nt4\connections for windows nt4**.

Note: "d:" corresponds to your CD-ROM drive.

9. Choose **Eicon (S-Series, C-Series, Other)**.
10. Choose **Automatic** or **Manual**.

Note: If Automatic does not find a card, choose **Manual**.

The driver that is detected or chosen is Eiconcard S94.

11. Follow the instructions in the window in order to complete the rest of the installation.

NetPro Discussion Forums - Featured Conversations

Networking Professionals Connection is a forum for networking professionals to share questions, suggestions, and information about networking solutions, products, and technologies. The featured links are some of the most recent conversations available in this technology.

NetPro Discussion Forums - Featured Conversations for Customer Contact Software
IP Communications and Video: Contact Center
IPCC express version - Oct 31, 2007
IPCC enterprise - Oct 31, 2007
IPCC-X CUCC-X BARS dmp file for offline reporting - Oct 31, 2007
Connecting to SQL 2005 Failing, IPCC 4.0.5 - Oct 31, 2007
IPCC Express Call Transfer without auto-log off (script problem) - Oct 31, 2007

Related Information

- [Cisco ICM Software Configuration Guide \(Version 5.0\)](#)
- [Technical Support & Documentation - Cisco Systems](#)

Home	How to Buy	Login	Profile	Feedback	Site Map	Help
----------------------	----------------------------	-----------------------	-------------------------	--------------------------	--------------------------	----------------------

All contents are Copyright © 2006-2007 Cisco Systems, Inc. All rights reserved. [Important Notices](#) and [Privacy Statement](#).