

# uBR7200 Series Router Architecture

Document ID: 16044

---

## **Introduction**

### **Before You Begin**

Conventions

Prerequisites

Components Used

### **Hardware Architecture**

Chassis Overview

Network Processing Engines and Memory

I/O Board

Port Adapters

Cable Cards

### **Boot Sequence**

### **Related Information**

---

## **Introduction**

This document is an overview of the hardware and software architecture of the Cisco uBR72XX series routers.

## **Before You Begin**

### **Conventions**

For more information on document conventions, see the Cisco Technical Tips Conventions.

### **Prerequisites**

There are no specific prerequisites for this document.

### **Components Used**

This document is not restricted to specific software and hardware versions.

## **Hardware Architecture**

### **Chassis Overview**

The uBR7200 series universal broadband routers comprise Cisco's Cable Modem Termination System (CMTS) solution. Three different chassis are available: the Cisco uBR7223, the Cisco uBR7246, and the Cisco uBR7246VXR.

- uBR7223: A two slot chassis with the legacy midplane.
- uBR7246: A four slot chassis with the legacy midplane.
- uBR7246VXR: A four slot chassis with the VXR midplane.

#### **uBR7223**

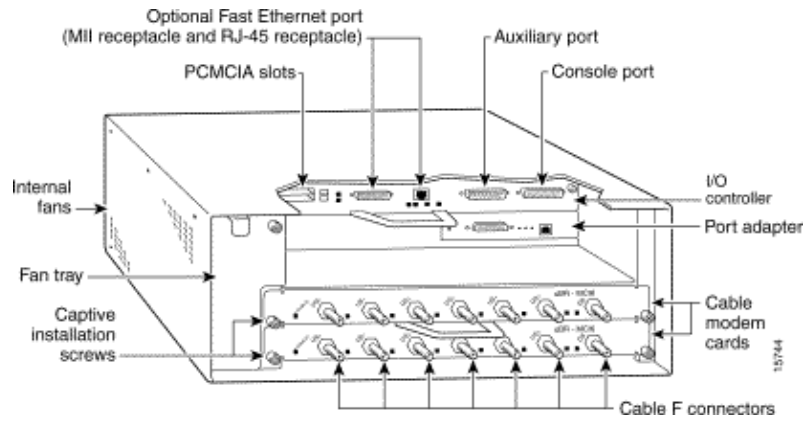

## uBR7246

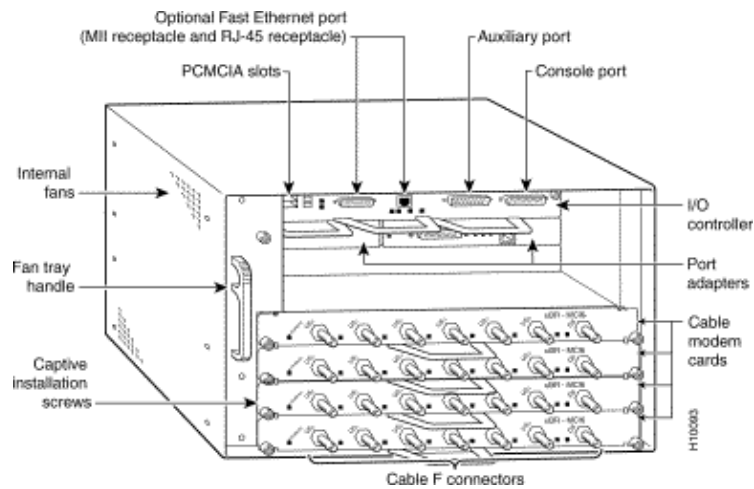

## uBR7246VXR

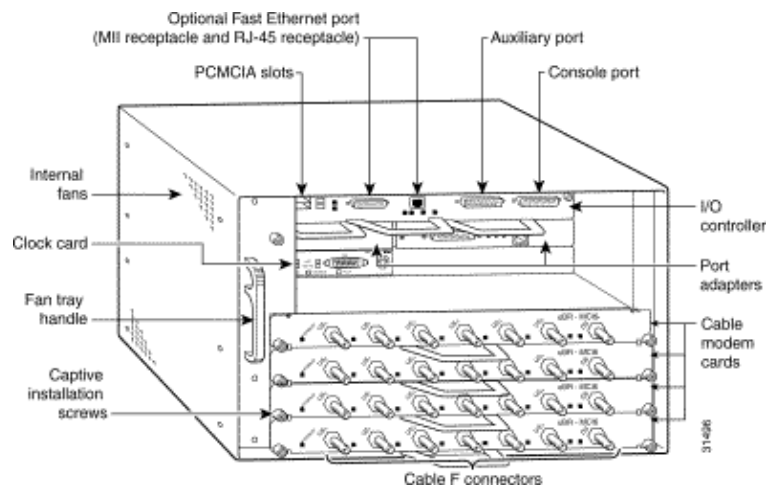

The routers are based on Data Over Cable Service Interface Specifications (DOCSIS) and support data and digitized voice connectivity over a bidirectional cable television and IP backbone network.

The uBR7200 series universal broadband routers contain:

- Cable modem cards that interface to the radio frequency (RF) cable plant.
- Port adapters that connect to the IP backbone and external networks.
- A Cisco Cable Clock Card that allows you to lock and propagate a T1 clock signal throughout the router midplane (UBR VXR only).

- One network processing engine (NPE) that performs system management functions for the chassis.
- An input/output (I/O) controller that contains a console port to connect data terminal equipment (DTE), auxiliary port to connect data communications equipment (DCE), two Personal Computer Memory Card International Association (PCMCIA) slots that hold Flash memory cards to remotely load and store multiple system and boot helper images, as well as an optional Fast Ethernet port to provide a 100 Mbps connection to the network.
- Power supply that provides power to the router.
  - ◆ The uBR7223 comes equipped with one 550W, AC-input or DC-input power supply.
  - ◆ The uBR7246VXR and uBR7246 support an optional, second power supply for load sharing and power redundancy.
- Midplane (Triple PCI Bus) that distributes power from the power supply to the I/O controller, bridges the peripheral component interconnect (PCI) buses from the port adapter(s) to the packet static random-access memory (SRAM) on the NPE-150 and NPE-200 or synchronous dynamic random-access memory (SDRAM) on the NPE-300, arbitrates traffic across the PCI buses, and generates clock signals for the port adapter on the PCI bus.
- Fan tray, enclosing internal fans that draw cooling air into the chassis to maintain an acceptable operating temperature:
  - ◆ The fan tray for the uBR7223 contains four fans.
  - ◆ The fan trays for the uBR7246VXR and uBR7246 each contain seven fans.

The cable modem cards, port adapters, clock card, NPE, I/O controller, and power supplies slide into their respective chassis slots and connect directly to the router's midplane. There are no internal cables to connect. The midplane distributes power from the power supplies to the I/O controller, cable modem cards, port adapters, clock card, fan tray, and NPE.

For more information, refer to Cisco uBR7200 Series Overview.

## Network Processing Engines and Memory

The NPE contains the main memory, the CPU, the PCI memory (static random-access memory (SRAM), except on the NPE-100 which uses DRAM), and the control circuitry for the PCI buses. The network processing engines consist of these components:

- A reduced instruction set computing (RISC) microprocessor. This table provides more information.

Network Processing Engine	Microprocessor	Internal Clock Speed
NPE-150	R4700	100 and 150 MHz
NPE-175	RM5270	200 MHz
NPE-200	R5000	200 MHz
NPE-225	RM5271	262 MHz
NPE-300	RM7000	262 MHz
NPE-400	RM7000	350 MHz

- A system controller.
  - ◆ The NPE-150, and NPE-200 have a system controller that uses direct memory access (DMA) to transfer data between DRAM and packet SRAM on the network processing engine.

- ◆ The NPE-300 has two system controllers that provide processor access to the two midplane and single I/O controller PCI buses. The system controller also allows port adapters on either of the two midplane PCI buses to access SDRAM.
- Upgradeable memory modules.
  - ◆ The NPE-150, and NPE-200 use DRAM for storing routing tables, network accounting applications, packets of information in preparation for process switching, and packet buffering for SRAM overflow (except in the NPE-100, which contains no packet SRAM). The standard configuration is 32 MB, with up to 128 MB available through single in-line memory module (SIMM) upgrades.
  - ◆ The NPE-300 uses SDRAM for storing all packets received or sent from network interfaces. The SDRAM also stores routing tables and network accounting applications. Two independent SDRAM memory arrays in the system allow concurrent access by port adapters and the processor. The NPE-300 has a fixed configuration caveat with the first 32MB SIMM.
- Packet SRAM for storing packets of information in preparation for fast switching.
  - ◆ The NPE-150 has 1 MB of SRAM.
  - ◆ The NPE-200 has 4 MB of SRAM.
  - ◆ The NPE-300 does not have packet SRAM.
- Cache memory.
  - ◆ The NPE-150 and NPE-200 have unified cache SRAM that functions as the secondary cache for the microprocessor (the primary cache is within the microprocessor).
  - ◆ The NPE-300 has three levels of cache: a primary and a secondary cache that are internal to the microprocessor, and a tertiary, 2-MB external cache that provides additional high-speed storage for data and instructions.
- Two environmental sensors for monitoring the cooling air as it leaves the chassis.
- Boot ROM for storing sufficient code for booting the Cisco IOS® software; the NPE-200, and NPE-300 have boot ROM.

For additional information, refer to:

- Troubleshooting the Network Processing Engine [uBR7200]
- Network Processing Engine [uBR7200]
- Network Processing Engine & Network Services Engine Documentation
- Network Processing Engine and Network Services Engine Installation and Configuration

The uBR7200 series router uses DRAM, SDRAM, and SRAM memory on the NPE in various combinations. The available memory is divided into three memory pools: the processor pool, the I/O pool, and the PCI pool (I/O-2 on NPE-300).

Below are some **show memory** command output examples.

In this example, a uBR7246 with an NPE 200 with 64 MB DRAM is used.

```
ubr7246-A# show memory
```

	Head	Total (b)	Used (b)	Free (b)	Lowest (b)	Largest (b)
Processor	612544C0	35306304	9386596	25919708	25692256	24872952
I/O	3400000	12582912	3416092	9166820	8750448	8818300
PCI	4B000000	4194312	2245784	1948528	1948528	1948476

In this example, a uBR7246VXR with an NPE 300 with 256 MB DRAM is used.

```
uBR7246VXR-1# show memory
```

	Head	Total(b)	Used(b)	Free(b)	Lowest(b)	Largest(b)
Processor	6184CA00	234567168	11795676	222771492	222646900	222652544
I/O	20000000	33554432	524296	33030136	32998448	33019132
I/O-2	F800000	8388608	2243588	6145020	5817032	6133436

This is the **show version** command, which display the system hardware configuration, software version, and names and sources of configuration files and boot images.

```
uBR7200# show version
```

```
Cisco Internetwork Operating System Software
IOS (tm) 7200 Software (UBR7200-K8P-M), Version 12.2(5.4)T, MAINTENANCE INTERIE
TAC Support: http://www.cisco.com/tac
Copyright (c) 1986-2001 by cisco Systems, Inc.
Compiled Fri 21-Sep-01 19:32 by ccai
Image text-base: 0x600089C0, data-base: 0x61688000
```

```
ROM: System Bootstrap, Version 11.1(10) [dschwart 10], RELEASE SOFTWARE (fc1)
BOOTLDR: 7200 Software (UBR7200-BOOT-M), Version 11.3(6)NA1, EARLY DEPLOYMENT R
```

```
Meowth uptime is 13 weeks, 3 days, 6 hours, 38 minutes
System returned to ROM by power-on
System image file is "slot0:ubr7200-k8p-mz.122-5.4.T"
```

```
cisco uBR7246 (NPE150) processor (revision B) with 57344K/8192K bytes of memory.
Processor board ID SAB03040053
R4700 CPU at 150Mhz, Implementation 33, Rev 1.0, 512KB L2 Cache
6 slot midplane, Version 1.0
```

```
Last reset from power-on
X.25 software, Version 3.0.0.
Primary Rate ISDN software, Version 1.1.
4 Ethernet/IEEE 802.3 interface(s)
24 Serial network interface(s)
4 Channelized T1/PRI port(s)
3 Cable Modem network interface(s)
125K bytes of non-volatile configuration memory.
1024K bytes of packet SRAM memory.
```

```
20480K bytes of Flash PCMCIA card at slot 0 (Sector size 128K).
4096K bytes of Flash internal SIMM (Sector size 256K).
Configuration register is 0x2102
```

- **Processor memory** This pool is used for storing the IOS software code, the routing tables, and the system buffers. It's allocated from the DRAM on the NPE-150, and the NPE-200; and SDRAM bank 0 on the NPE-300.
- **I/O memory** This pool is used for particle pools. Both the interface private pools and the public particle pool are allocated from this memory. The size of this memory depends on the type of NPE. NPE-150 and NPE-200 use different formulas to determine how much DRAM should be used for I/O memory, whereas the NPE-300 uses its SDRAM bank 1 which is fixed at 32 MB.
- **PCI memory** This small pool is mainly used for interface receive and transmit rings. It is sometimes used to allocate private interface particle pools for high-speed interfaces. On NPE-300 systems, this pool is created in SDRAM. On the NPE-150 and NPE-200, it's created entirely on SRAM.

For detailed information about the location and memory table specifications, refer to Memory Location and Specifications. From this link, you can also find some memory-related guidelines and restrictions classified by NPE/NSE.

Also, refer to Memory Replacement Instructions for the Network Processing Engine or Network Services Engine and Input/Output Controller for more information.

## I/O Board

The I/O controller shares the system memory functions and the environmental monitoring functions for the uBR7200 router with the network processing engine.

The I/O controller consists of these components:

- Dual EIA/TIA–232 channels for local and auxiliary console ports. The console port has full DCE functionality and a DB–25 receptacle. The auxiliary port has full DTE functionality and a DB–25 connector.
- Optional Fast Ethernet port that is configurable for use at 100–Mbps full–duplex or half–duplex (half–duplex is the default). The Fast Ethernet port is equipped with an MII receptacle and an RJ–45 receptacle.
- NVRAM for storing the system configuration and environmental monitoring logs. NVRAM uses lithium batteries to maintain its contents when disconnected from power.
- Two PCMCIA slots for Type II Flash memory cards.
- Flash memory SIMM and Flash memory cards for storing the boot helper image and the default IOS software image.

```
uBR7200# show flash
```

```
  #-  ED  --type--  --crc---  -seek--  nlen  -length-  -----date/time-----  name
  1  ..  image    FB8463E9  857AF0   25  8616560  Sep 16 2001 06:14:14  ubr7200-k1pC
  2  ..  image    9DE70200 112EC88  24  9269528  Sep 16 2001 06:40:07  ubr7200-k8pT

2691960 bytes available (17886344 bytes used)
```

- Erasable programmable read–only memory (EPROM) for storing sufficient code for booting the IOS software.
- Two environmental sensors for monitoring the cooling air as it enters and leaves the uBR7200 series chassis. The command used to display environmental status information ( for example– power supply, fan status and temperature information) and information about power available to the system.

```
uBR7200# show environment all
```

```
Power Supplies:
Power supply 1 is AC Revision C0. Unit is on.
Power supply 2 is empty. Temperature readings:
chassis inlet      measured at 21C/69F
chassis outlet 1   measured at 22C/71F
chassis outlet 2   measured at 23C/73F
chassis outlet 3   measured at 34C/93F
chassis outlet 4   measured at 21C/69F
chassis outlet 5   measured at 22C/71F
```

```
Voltage readings:
+3.5 V  measured at +3.45 V
+5.2 V  measured at +5.12 V
+12.2 V measured at +12.12 V
-12.2 V measured at -12.32 V
+16 V   measured at +16.05 V
-16 V   measured at -16.83 V
```

This table provides more information on I/O controller descriptions.

## Product Number

## Description

UBR7200-I/O-FE

1 Fast Ethernet port

UBR7200-I/O

Has no Fast Ethernet port

**Note:** The I/O controllers for the 7200 series are not the same as the I/O controllers for the uBR7200 series. 7200 series controllers are not supported in the uBR7200.

Refer to these links for more information:

- [Troubleshooting the I/O Controller \[uBR7200\]](#)
- [Input/Output Controller \[uBR7200\]](#)

## Port Adapters

These are modular interface controllers that contain circuitry to transmit and receive packets on the physical media.

The port adapters (PAs) installed in the uBR7200 routers support Online Insertion and Removal (OIR). They are hot-swappable.

This table lists the port adapters that are supported on the uBR7200 series.

Product Number	Description
PA-2FEISL-FX=	2-port Fast Ethernet 100BASE FX
PA-2FEISL-TX=	2-port Fast Ethernet 100BASE TX
PA-2H=	2-port HSSI
PA-4E=	4-port Ethernet 10BASET
PA-8E=	8-port Ethernet 10BASET
PA-A3-OC3MM=	1-port ATM enhanced OC3C/STM1 Multimode
PA-A3-OC3SMI=	1-port ATM enhanced OC3C/STM1 Singlemode (IR)
PA-A3-OC3SML=	1-port ATM enhanced OC3C/STM1 Singlemode (LR)
PA-FE-TX=	1-port Fast Ethernet 100BASE TX
PA-FE-FX=	1-port Fast Ethernet 100BASE FX
PA-H=	1-port HSSI
PA-POS-OC3MM=	1-port Packet over SONET OC3C/STM1 MULTIMODE

PA-POS-OC3SMI=	1-port Packet over SONET OC3C/STM! Singlemode
PA-POS-OC3SML=	1-port Packet over SONET OC3C/STM! Singlemode (LR)
PA-SRP-OC12MM=	DPT-OC12 Multimode
PA-SRP-OC12SMI=	DPT-OC12 Singlemode (IR)
PA-SRP-OC12SML=	DPT-OC12 Singlemode (LR)
PA-GE	Gigabit Ethernet
UBR-CLK-T1=	National clock card for UBR-VXR *

Refer to these links for more information:

- Troubleshooting Port Adapters [uBR7200]
- Troubleshooting the Cisco Cable Clock Card (Cisco uBR7246VXR only)
- uBR7200 Port Adapter Release Matrix
- Cisco Software Advisor ( registered customers only)

## Cable Cards

Cisco cable modem cards, together with IF-to-RF upconverters, serve as the RF interface between the cable headend and DOCSIS-based cable modems or EuroDOCSIS-based cable modems and set-top boxes (STBs).

The cable modem cards connect directly to the universal broadband router's midplane. Cable modem cards installed in the uBR7200 series support Online Insertion and Removal (OIR). They are hot-swappable. This table provides a list of product numbers and their description.

Product Number	Description
UBR-MC11C=	1 downstream, 1 upstream
UBR-MC12C=	1 downstream, 2 upstream
UBR-MC14C=	1 downstream, 4 upstream
UBR-MC16C=	1 downstream, 6 upstream
UBR-MC16E=	8MHZ, 1 downstream, 6 upstream
UBR-MC16S=	Spectrum Management, 1 downstream, 6 upstream
UBR-MC28C=	2 downstream, 8 upstream

Refer to Cisco uBR7200 Series Universal Broadband Router Cable Interface Line Card Hardware Installation for additional information.

## Boot Sequence

During the boot process, observe the system LEDs to identify problems.

When you start up the system by turning on the power supply switch, the following should occur:

1. You should immediately hear the fans operating.

2. The power supply's green power OK LED (at the rear of the chassis) should go on immediately when you place the power supply switch in the on (I) position, and remain on during normal system operation.
3. The LEDs on the I/O controller should go on.
4. The enabled LED on each port adapter should go on. The enable LED on the clock card will also come on at this time on the uBR7246VXR.
5. The enabled LED on each cable modem card goes on when the network processing engine completes its initialization of the cable modem card for operation.
6. When all LEDs go on to indicate that the system has booted successfully, the initial system banner should be displayed on the console screen.

If the boot sequence does not occur as described above, refer to [Identifying Startup Problems](#) for additional information.

Refer to [Hardware Troubleshooting the Cisco uBR72xx / uBR7246 VXR Universal Broadband Router](#) for additional information.

---

## Related Information

- [Cisco 7200 Parity Error Fault Tree](#)
- [Troubleshooting \[uBR7200\]](#)
- [Cisco uBR7200 Series Hardware Installation Guide](#)
- [Cisco uBR7200 Universal Broadband Routers](#)
- [Product Support](#)
- [Technical Support – Cisco Systems](#)

---

[Contacts & Feedback](#) | [Help](#) | [Site Map](#)

© 2008 – 2009 Cisco Systems, Inc. All rights reserved. [Terms & Conditions](#) | [Privacy Statement](#) | [Cookie Policy](#) | [Trademarks of Cisco Systems, Inc.](#)

---

Updated: Jan 02, 2006

Document ID: 16044

---