

# How to Switch Over Cable Telco–Return to Two–Way RF Return Path

Document ID: 12214

---

## Introduction

### Prerequisites

- Requirements
- Components Used
- Conventions

### Example of a Mixed Telco–Return and Two–Way Environment

### Decision Process of the Cable Modem to Know If the System is Telco–Return or Two–Way Return Path

### Switching Modes in a Dual Telco–Return Modem Automatically

### Ways of Switching the Dual Cable Modem from Telco–Return to Two–Way Modes Manually

- Using the DOCSIS Configuration File
- Using SNMP
- Resetting to Factory Default

### Related Information

---

## Introduction

This document explains how to perform a cut–over from a Telco–Return (one–way) scenario to a two–way Radio Frequency (RF) return path. In a two–way plant scenario, cable modems use an RF upstream instead of an asynchronous Point–to–Point Protocol (PPP) return path via the Public Switched Telephone Network (PSTN) (see Figure 1). This cut–over process is usually done after a cable plant has upgraded their unidirectional amplifiers to bidirectional and can therefore support a RF transmission in both the forward and return paths. The challenge for Multiple Service Operators (MSOs) is to make the cut–over with a minimal impact to paying subscribers in a live Hybrid Fiber–Coaxial (HFC) network.

Figure 1 – Telco–Return Diagram

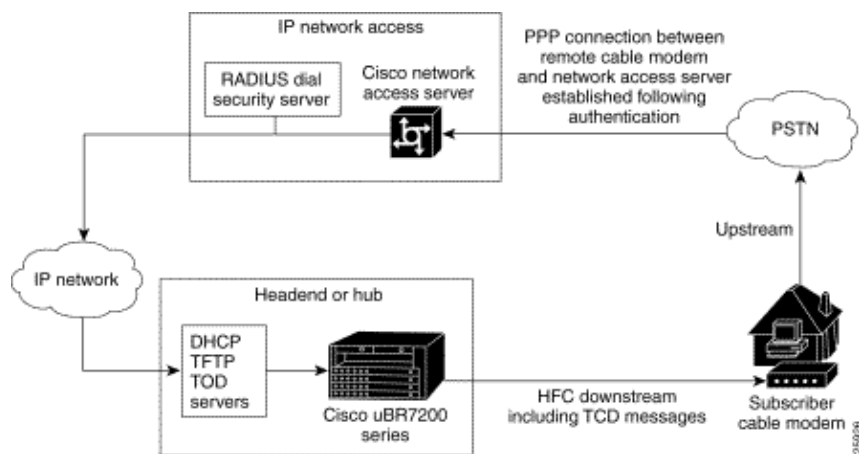

The ability to perform such a cut–over seems complex physically, and may potentially interrupt service by losing Internet connectivity for longer than desirable periods. However, this should not be the case if executed correctly. This is because a Cisco uBR7246 Cable Modem Termination System (CMTS) can support both modes: Telco–Return and two–way return paths mode at the same time on the same headend and the same cable linecard.

**Note:** It is important to know that, before converting all your modems to two-way, you should carefully select the upstream frequency (the example uses 24000000 MHz). Also, make sure the return path is available and clean by using a spectrum analyzer. To learn how to measure the upstream, refer to Cable FAQ. When performing a cut-over from Telco-Return to two-way, it is recommended to first try the cut-over with a few cable modems inside the cable plant headend and a small sample out in the field. This can be done initially as a test to check if there are any return path issues before rolling out the cut-over.

## Prerequisites

## Requirements

There are no specific requirements for this document.

## Components Used

This document uses these specific software and hardware versions:

- uBR7223 with Cisco IOS® software 12.0(5)T
- Cisco Network Registrar (CNR) version 3.5.3

## Conventions

Refer to Cisco Technical Tips Conventions for more information on document conventions.

## Example of a Mixed Telco-Return and Two-Way Environment

This portion of a CMTS configuration shows the necessary commands that are relevant to Telco-Return.

```
interface Cable2/0
  ip address 10.10.169.1 255.255.255.0 secondary
  ip address 10.10.168.1 255.255.255.0
  no ip directed-broadcast
  cable helper-address 172.16.135.20
  no ip route-cache
  no ip mroute-cache
  no keepalive
  cable insertion-interval automatic 25 500
  cable dhcp-giaddr policy
  cable downstream annex B
  cable downstream modulation 64qam
  cable downstream interleave-depth 32
  cable downstream frequency 117000000
  cable upstream 0 frequency 24000000
  cable upstream 0 power-level 0
  cable upstream 0 range-backoff 0 6
  no cable upstream 0 shutdown
  cable Telco-Return enable
  cable Telco-Return spd 1 factory-default
  cable Telco-Return spd 1 threshold 255
  cable Telco-Return spd 1 dial-timer 1200
  cable Telco-Return spd 1 manual-dial
  cable Telco-Return spd 1 dhcp-authenticate
  cable Telco-Return spd 1 dhcp-server 172.16.135.20
  cable Telco-Return spd 1 ppp-authenticate pap
  cable Telco-Return spd 1 phonenum 2489888
  cable Telco-Return spd 1 username test
```

```

cable Telco-Return spd 1 password test
!

```

For a complete configuration of Telco-Return and explanation of the commands used in the preceding example, refer to Telco-Return for the Cisco uBR7200 Series Universal Broadband Router.

The next example is the **show cable qos profile** and the **show cable modem** output with respect to the working configuration. The output shows an example of a mixed Telco-Return and two-way environments in the same CMTS. Notice that all the cable modems shown here are in the same cable interface (Cable2/0).

**Note:** The modems that have a **T** are for Telco-Return and those with a **U0** are for two-way modems using upstream port 0. Both modes are on the same MC16C card interface Cable2/0.

```

ubr7223#show cable modem

```

Interface	Prim Sid	Online State	Timing Offset	Rec Power	QoS	CPE	IP address	MAC address
Cable2/0/T	94	online	0	0.00	3	2	10.10.169.151	0020.4066.b6b
Cable2/0/T	95	online	0	0.00	3	1	10.10.168.18	0020.4061.db5
<b>Cable2/0/T</b>	<b>96</b>	<b>online</b>	<b>0</b>	<b>0.00</b>	<b>3</b>	<b>1</b>	<b>10.10.169.240</b>	<b>0020.4066.b64</b>
<b>Cable2/0/U0</b>	<b>97</b>	<b>online</b>	<b>307</b>	<b>0.25</b>	<b>4</b>	<b>1</b>	<b>10.10.168.108</b>	<b>0020.4002.fc7</b>
Cable2/0/T	98	online	0	0.00	3	1	10.10.169.245	0020.4003.65f
Cable2/0/U0	99	online	332	0.25	4	0	10.10.168.110	0020.400b.9b4
Cable2/0/U0	100	online	277	0.25	4	1	10.10.169.114	0020.4002.ff4
Cable2/0/T	101	online	0	0.00	3	1	10.10.169.175	0020.4066.b6c
Cable2/0/U0	102	online	272	0.25	4	1	10.10.168.115	0020.400b.9b8
Cable2/0/T	103	online	0	0.00	3	1	10.10.168.204	0020.4003.678
Cable2/0/T	104	online	0	0.00	3	1	10.10.168.66	0020.400b.9af
Cable2/0/T	105	online	0	0.00	3	1	10.10.169.107	0020.4065.d75
Cable2/0/T	106	online	0	0.00	3	2	10.10.168.193	0020.4065.914
Cable2/0/T	107	online	0	0.00	3	2	10.10.168.96	0020.4066.d2b
Cable2/0/T	108	online	0	0.00	3	1	10.10.169.118	0020.4003.711
Cable2/0/T	109	online	0	0.00	3	1	10.10.168.202	0020.4003.6b2
Cable2/0/U0	111	online	227	0.25	4	1	10.10.169.117	0020.4002.fd0
Cable2/0/T	112	online	0	0.00	3	0	10.10.169.127	0020.4062.1ba
Cable2/0/T	113	online	0	0.00	3	1	10.10.169.109	0020.400b.9a2
Cable2/0/T	114	online	0	0.00	3	1	10.10.168.229	0020.4061.65e
Cable2/0/T	115	online	0	0.00	3	1	10.10.169.173	0020.4002.ffb
Cable2/0/T	116	online	0	0.00	3	1	10.10.169.38	0020.407e.a54
Cable2/0/T	117	online	0	0.00	3	1	10.10.168.77	0020.4084.178

An interesting point to note is that both modes (Telco-Return and two-way) are using different DOCSIS configuration files, as seen in the output **show cable qos profile** in comparison to the **show cable modem** command. All online Telco-Return modems are using QoS #3 and two-way are using QoS #4.

In this example, there are two DOCSIS configuration files. One file uses Telco-Return with QoS #3, the other file uses two-way with QoS #4.

```

ubr7223#show cable qos profile

```

Service class	Prio	Max upstream bandwidth	Guarantee upstream bandwidth	Max downstream bandwidth	Max tx burst	TOS mask	TOS value	Create by	B priv enab
1	0	0	0	0	0	0x0	0x0	cmts(r)	no
2	0	64000	0	1000000	0	0x0	0x0	cmts(r)	no
<b>3</b>	<b>1</b>	<b>128000</b>	<b>0</b>	<b>512000</b>	<b>0</b>	<b>0x0</b>	<b>0x0</b>	<b>cm</b>	<b>no</b>
4	7	32000	0	265000	0	0x0	0x0	cm	no

## Decision Process of the Cable Modem to Know If the System is Telco-Return or Two-Way Return Path

The General Instruments (GI) SURFboard SB2100D and 3100D modems have the ability to do both two-way and Telco-Return. The D in 2100D and 3100D stands for dual capable. When the dual modem comes fresh out of the box, and is installed in the system for the first time, it is initialized in an unknown state. In the unknown state, the cable modem listens for messages in the downstream to learn how to acquire an upstream. If the cable modem hears Upstream Channel Descriptors (UCD) it attempts to make a connection on the RF return path. If the cable modem hears Telephone Channel Descriptors (TCD) it attempts to make an upstream connection using the internal PPP modem (inside the GI modem) via the PSTN after failing to acquire the upstream RF Return path. Usually, dual GI cable modems look for UCDs first. If the cable modem is using Telco-Return, a UCD message is not received. The cable modem starts looking for TCDs.

## **Switching Modes in a Dual Telco-Return Modem Automatically**

A Telco-Return dual D modem does not have the ability to automatically switch back and forth between modes. Once the dual cable modem acquires an upstream successfully, no matter what mode that is, the dual modem stays in that mode until modified by the system operator. The SB2100D and the SB3100D do not have the ability to automatically switch between RF and Telco-Return modes. Once the modem has registered in Telco-Return mode, it ignores UCDs.

## **Ways of Switching the Dual Cable Modem from Telco-Return to Two-Way Modes Manually**

The system operator may use three different ways to change the dual modem to RF two-way mode:

- Using the DOCSIS Configuration File
- Using SNMP
- Resetting to Factory Default

### **Using the DOCSIS Configuration File**

The DOCSIS configuration file can be modified. Change the value for the Upstream Channel ID which dictates the mode:

- 0 = Telco-Return
- 1 or greater = RF Return

**Figure 2 – Cisco DOCSIS CPE Configurator V3.0a**

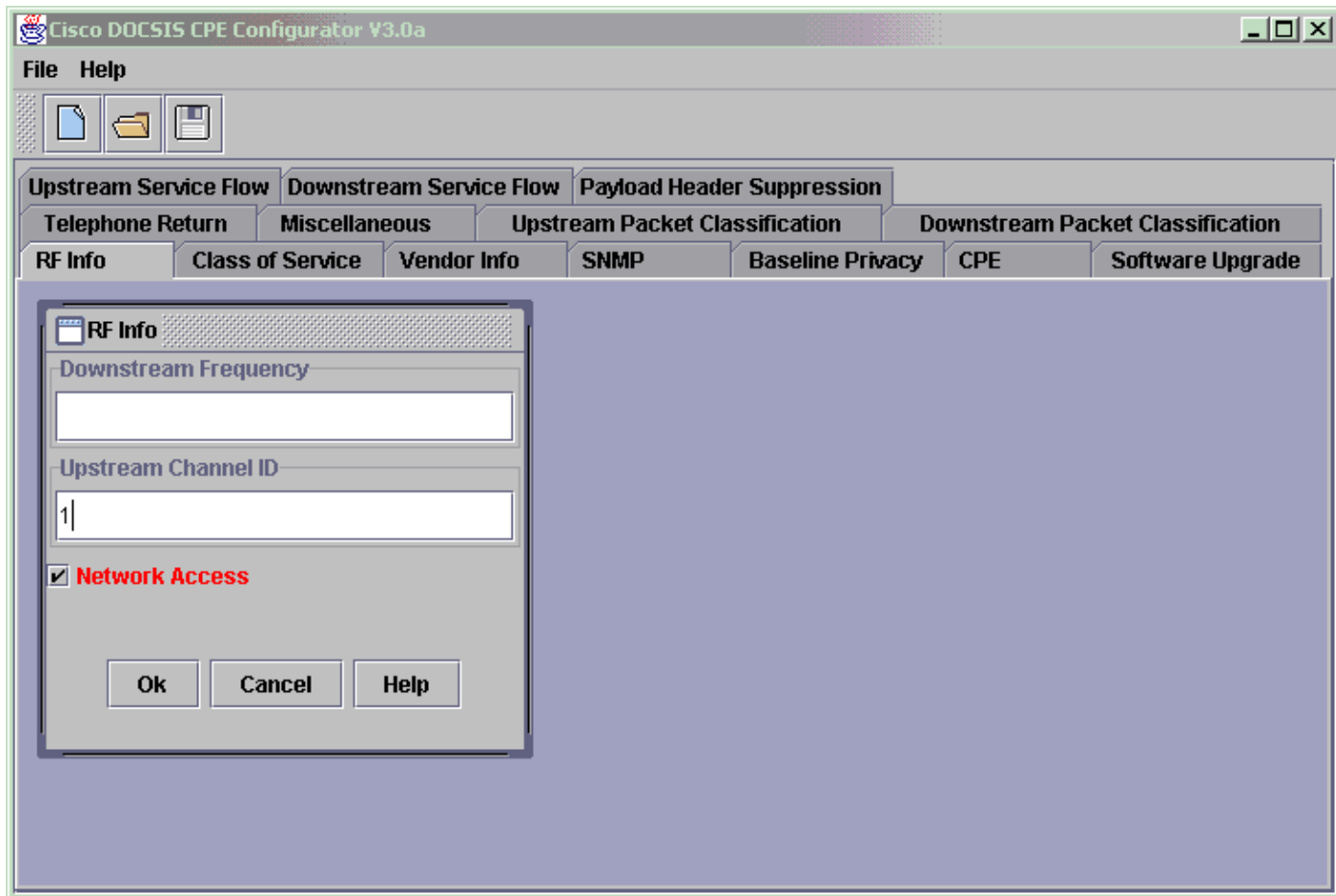

This is a screen capture of the Cisco DOCSIS Configurator V3.0 used for setting the Upstream Channel ID for RF Return path.

To perform a cut-over, you can create one or two DOCSIS configuration files. This depends on how quickly you want to perform the transition. If you want to change all modems from Telco-Return to two-way in one step, you would only need to edit the current Telco-Return DOCSIS configuration file in the Upstream Channel ID field (see Figure 2) from a 0 to either a 1, or a blank. Afterwards, power cycle the modems forcing them to grab the new parameters. This enables two-way mode. If you want to perform a more gradual cut-over, where only a percentage of the Telco-Return modems are converted to two-way, you need two DOCSIS configuration files, as shown in Figure 2. It also is necessary to enable Client Class Processing on CNR. To minimize risks, it is recommended that the cut-over is performed gradually in a production environment.

## Using SNMP

The second method is to switch the mode via Simple Network Management Protocol (SNMP) using the 3Com provided public Management Information Base (MIB): TelcoReturnCABLE-DEVICE-MIB.

Using the docsTrCmMode MIB object, you can adjust the upstream selection as shown in the MIB properties value table. This object, which has the OID of 1.3.6.1.2.1.10.128.1.1.2, represents the cable modem operating mode. A cable modem may be operating in these modes with the MIB integer values as indicated in this table.

Mode	MIB Integer Value
Other	1
Telco-Return	2

Two Way	3
---------	---

Using the DOCSIS Configurator Tool (see Figure 3), you can set the docsTrCmMode MIB object from Telco-Return mode to two-way mode during a cut-over by setting the integer value equal to 3.

**Figure 3 – Cisco DOCSIS CPE Configurator V3.0a**

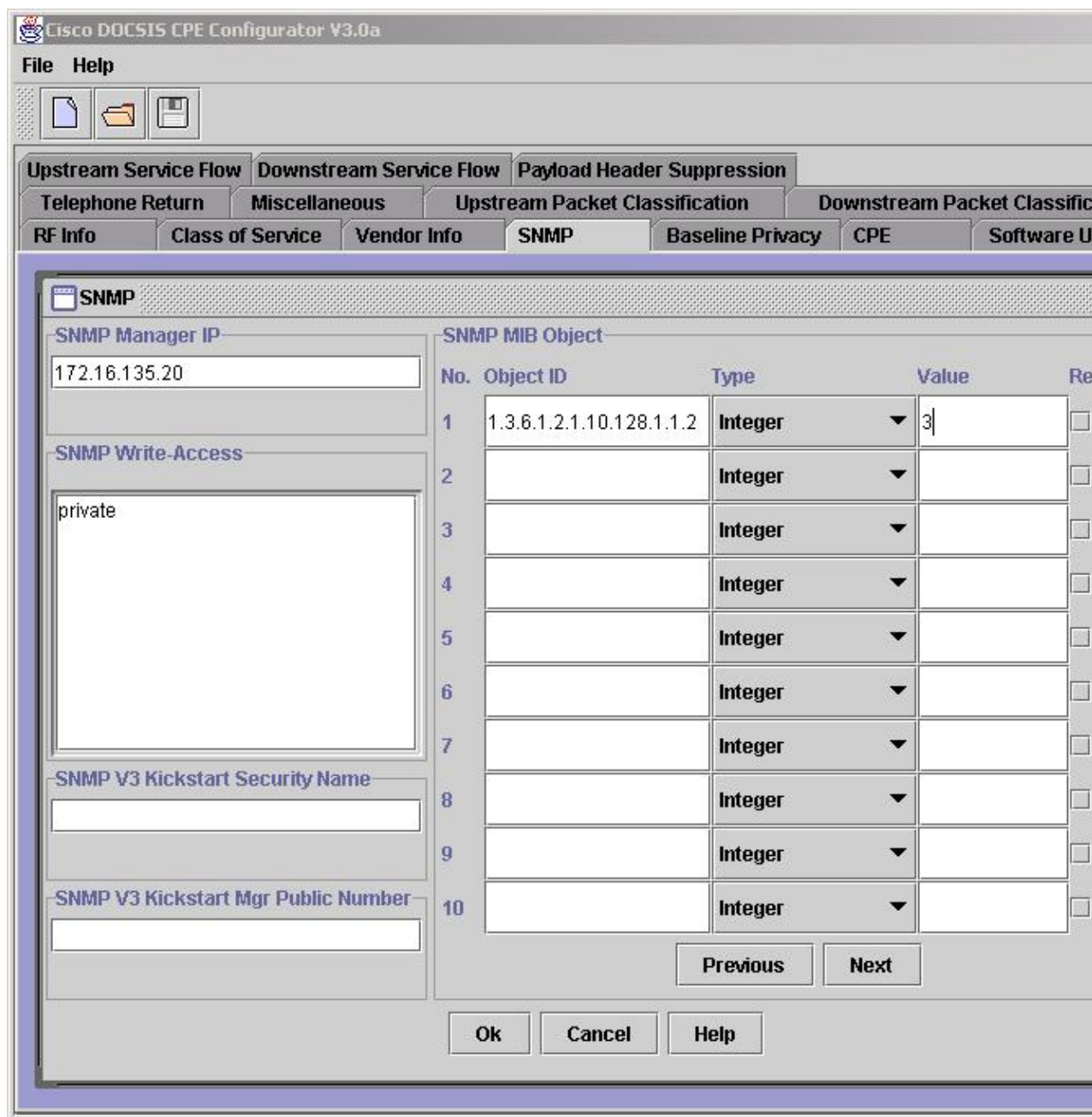

This is a screen capture of the Cisco DOCSIS Configurator V3.0 use for setting the docTrCmMode MIB.

This is a portion of the MIB definition that contains the MIB object docsTrCmMode:

```
Name: docsTrCmMIB
Type: MODULE-IDENTITY
OID: 1.3.6.1.2.1.10.128
Full path:
iso(1).org(3).dod(6).internet(1).mgmt(2).mib-2(1).transmission(10).docsTrCmMIB(128)
Module: TelcoReturnCABLE-DEVICE-MIB
```

Parent: transmission  
First child: docsTrCmMIBObjects  
Prev sibling: docsIfMib  
Last updated: July 28, 98 at 09:20 GMT (9807280920Z)  
Organization: 3Com - Cable Access  
Contact: Jack Fijolek/Srinivyasa Murthy Adiraju  
Postal: 3Com  
3800 Golf Road  
Rolling Meadows, IL 60008  
Tel: +1 847 2622201 +1 847 2622205  
Fax: +1 847 2620258  
E-mail: Srinivyasa\_Adiraju@3Com.com  
Description: Telco-Return MIB for Data Over Cable Access modems and termination systems

## Resetting to Factory Default

This method involves your cable modem and PC.

The third way to switch from Telco-Return to two-way mode is having you reset to factory default. This method is accomplished by using an HTML Configuration Manager User Interface web page. Using this tool, you can make the modem think that it is "right out of the box" in an unknown state. In this unknown state, the modem scans for the best return path on next boot up.

When the modem is reset to factory default, it listens for UCDs and attempts to make a connection on the RF return. If the modem cannot find an upstream path, it listens for TCDs.

To access the HTML Configuration Manager User Interface, complete these steps:

1. Connect a straight-through Ethernet cable from your PC to the RJ-45 Ethernet port of your dual GI Telco-Return cable modem.
2. Type `http://192.168.100.1/config.html` in your browser.
3. Configure the TCP/IP properties with an IP address on the same subnet as 192.168.100.0/24.

For example, you can set the IP address 192.168.100.2 with a mask of 255.255.255.0, and a default gateway of 192.168.100.1. Once you set the TCP/IP properties, and can ping the IP address 192.168.100.1 from your PC, you should be able to launch the diagnostic tool with a browser. A diagnostic HTML Configuration Manager page opens and allows you to reset the modem to the factory default. Figure 4 shows how to reset to factory default by clicking on the **Reset to Defaults** button. Notice that this picture shows only the bottom part of the web page.

**Note:** This method is the least desirable because you must have end users (subscribers) involved in the cut-over process, or field engineers may be sent to your location to perform the cut-over process.

### Figure 4 – Reset To Factory Screen on a Surfboard SB3100D Telco-Return Modem

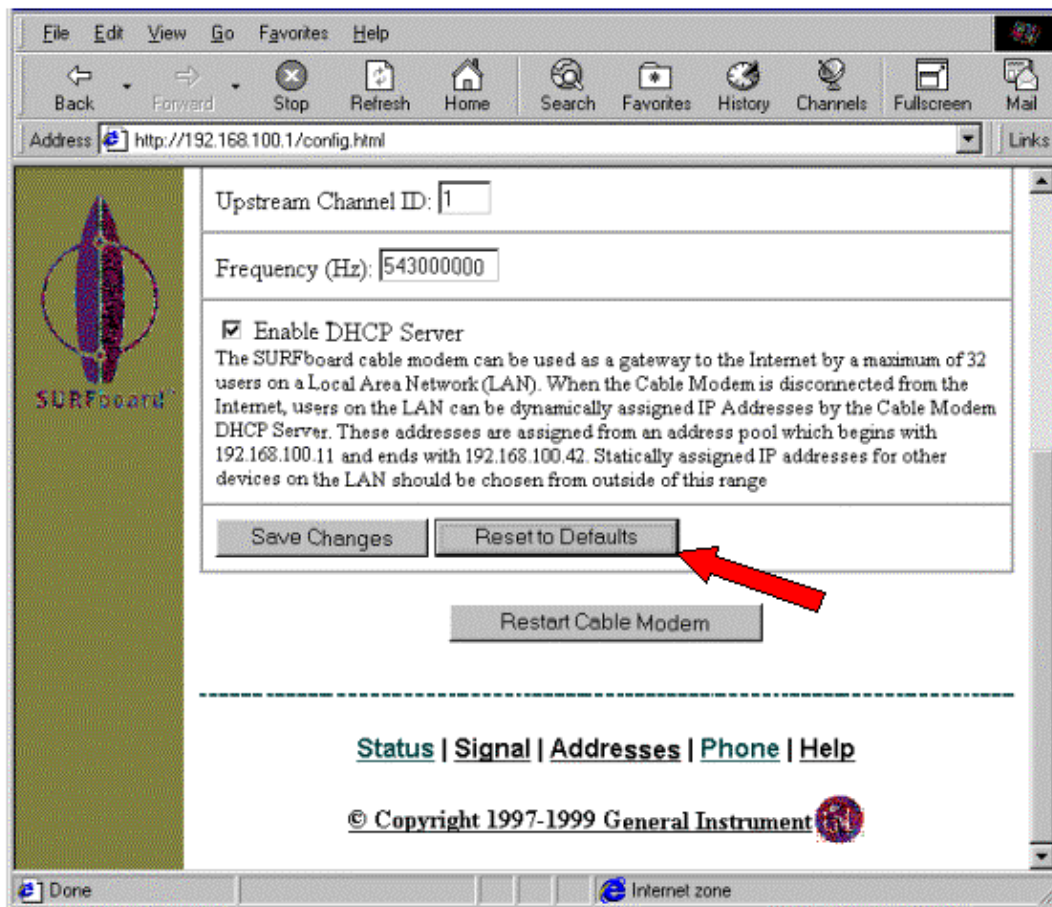

## Related Information

- [Cable FAQ](#)
- [Telco—Return for the Cisco uBR7200 Series Universal Broadband Router](#)
- [Telephone Return for the Cisco uBR7200 Series Cable Router](#)
- [Enhanced—Spectrum Management and Telephone Return for the Cisco uBR7200 Series Cable Router](#)
- [Technical Support & Documentation – Cisco Systems](#)

[Contacts & Feedback](#) | [Help](#) | [Site Map](#)

© 2009 – 2010 Cisco Systems, Inc. All rights reserved. [Terms & Conditions](#) | [Privacy Statement](#) | [Cookie Policy](#) | [Trademarks of Cisco Systems, Inc.](#)

Updated: May 18, 2006

Document ID: 12214