

Bundling NxE1 Links With a Multilink Interface

Document ID: 11044

Introduction

Prerequisites

Requirements

Components Used

Conventions

Background Theory

Configure

Network Diagram

Configurations

Verify

Troubleshoot

Troubleshooting Procedure

Troubleshooting Commands

Related Information

Introduction

The sample configurations in this document show how you can bundle NxE1 links (with or without G.704 framing) by means of a Multilink interface. The Multilink interface is introduced in Cisco IOS® Software Release 12.0(3)T for distributed Multilink Point to Point Protocol (PPP) on Cisco 7500 router Versatile Interface Processor (VIP)–based T1 or E1 interfaces (see the Related Information section of this document). The Multilink interface is supported for non–VIP based T1/E1 (and other WAN) interfaces since Cisco IOS Software Release 12.0(4)T.

Prerequisites

Requirements

Since Multilink PPP increases the CPU load, you are advised to:

1. Verify the current average CPU load before you add Multilink interfaces or add E1 links to a Multilink interface.
2. Use distributed Multilink PPP on Cisco 7500 VIP–based platforms whenever possible. Refer to the Cisco IOS Software Release 12.0(3)T New Feature Documentation for more details on the restrictions and prerequisites of distributed Multilink PPP (see the Related Information section of this document).
3. Disable Multilink PPP fragmentation whenever possible.

Note: This increases latency over the Multilink bundle.

Components Used

The information in this document is based on these software and hardware versions:

- A Cisco 7505 router equipped with VIP2–50 and PA–MC–8E1 that runs Cisco IOS Software Release 12.1(11a).
- A Cisco 7206 router equipped with PA–MC–8E1 that runs Cisco IOS Software Release 12.1(11).

The information in this document was created from the devices in a specific lab environment. All of the devices used in this document started with a cleared (default) configuration. If your network is live, make sure that you understand the potential impact of any command.

Conventions

Refer to the Cisco Technical Tips Conventions for more information on document conventions.

Background Theory

Multilink PPP, standardized in RFC 1990, is similar to load balancing techniques in that it sends packets across the individual links in a round robin fashion. However, Multilink PPP adds three significant capabilities.

- Since Multilink PPP works at the link layer, it makes an NxT1/E1 bundle appear as one logical link to the upper layer protocols in the router. Therefore, only one network address needs to be configured for the entire NxT1/E1 bundle.
- Multilink PPP keeps track of packet sequencing and buffers packets that arrive early. Multilink PPP preserves packet order across the entire NxT1/E1 bundle with this ability.
- You can enable packet fragmentation to split large data packets into smaller packet fragments that are individually transmitted across the links. In many circumstances, fragmentation can increase the efficiency of the NxT1/E1 link.

Multilink PPP also offers significant link manageability. If an individual link fails, Multilink PPP can automatically detect the failure and remove that link from the bundle. As long as one link of the bundle works, the logical interface that represents the bundle is up. With the use of keep alive signals, Multilink PPP can detect when a previously failed link comes back up and then reinsert that link into the bundle. Additionally, you can add more links to the bundle when you configure them as a member of the bundle when more bandwidth is needed. No reconfiguration at the network layer, such as new addressing, is needed. This is also a significant factor when you consider the use of advanced router services. For example, you can configure a specific Quality of Service once for the bundle as a whole rather than on each link in the bundle.

The trade-off for the increased functionality is that Multilink PPP requires greater CPU processing than load balancing solutions. Packet reordering, fragment reassembly, and the Multilink PPP protocol itself increases the CPU load.

Configure

This section presents you with the information to configure the features this document describes.

Note: Use the Command Lookup Tool (registered customers only) to find additional information on the commands this document uses.

Network Diagram

This document uses this network setup.

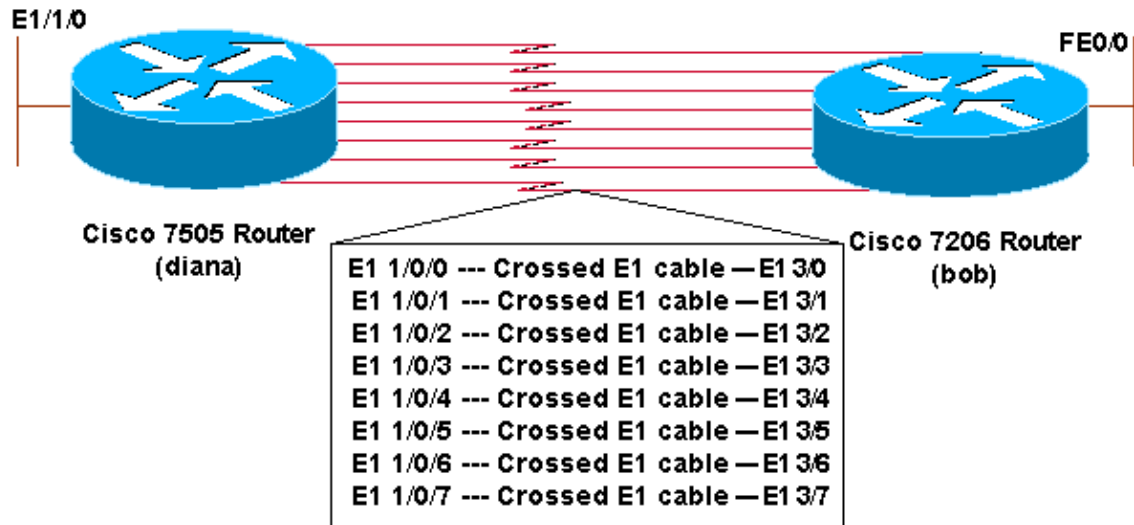

Configurations

This document uses these configurations.

- E1 Links with G.704 Framing
- E1 Links with No G.704 Framing

E1 Links with G.704 Framing

```

Cisco 7505
version 12.1
service timestamps debug datetime msec
service timestamps log datetime msec
no service password-encryption
!
hostname diana
!
enable password <password>
!
username bob password 0 mlppp

!--- This is an optional Challenge Handshake Authentication Protocol
!--- (CHAP) secret shared with the remote router.

!
!
!
ip subnet-zero
ip cef distributed

!--- This command is mandatory for distributed Multilink PPP.

!
no ip domain-lookup
!
!
controller E1 1/0/0
channel-group 0 timeslots 1-31

!--- You must assign all timeslots to one channel-group.

!

```

```
controller E1 1/0/1
  channel-group 0 timeslots 1-31

!--- You must assign all timeslots to one channel-group.
!
controller E1 1/0/2
  channel-group 0 timeslots 1-31

!--- You must assign all timeslots to one channel-group.
!
controller E1 1/0/3
  channel-group 0 timeslots 1-31

!--- You must assign all timeslots to one channel-group.
!
controller E1 1/0/4
  channel-group 0 timeslots 1-31

!--- You must assign all timeslots to one channel-group.
!
controller E1 1/0/5
  channel-group 0 timeslots 1-31

!--- You must assign all timeslots to one channel-group.
!
controller E1 1/0/6
  channel-group 0 timeslots 1-31

!--- You must assign all timeslots to one channel-group.
!
controller E1 1/0/7
  channel-group 0 timeslots 1-31

!--- You must assign all timeslots to one channel-group.
!
interface Multilink1
  ip address 10.10.10.1 255.255.255.0
  no cdp enable
  ppp multilink
  no ppp multilink fragmentation

!--- This command is optional to reduce CPU load.

  multilink-group 1
!
interface Serial1/0/0:0
  no ip address
  ip route-cache distributed

!--- This command is default and mandatory for distributed Multilink PPP.

encapsulation ppp
  tx-queue-limit 26
no fair-queue

!--- This command is mandatory to enable first-in, first-out (FIFO)
!--- queueing on the Serial interface.
```

```
ppp authentication chap

!--- This is an optional command needed for when you
!--- interface to a non-Cisco router.

ppp multilink
multilink-group 1
!
interface Serial1/0/1:0
no ip address
ip route-cache distributed

!--- This command is default and mandatory for distributed Multilink PPP.

encapsulation ppp
tx-queue-limit 26
no fair-queue

!--- This command is mandatory to enable FIFO queueing on
!--- the Serial interface.

ppp authentication chap

!--- This is an optional command needed for when you
!--- interface to a non-Cisco router.

ppp multilink
multilink-group 1
!
interface Serial1/0/2:0
no ip address
ip route-cache distributed

!--- This command is default and mandatory for distributed Multilink PPP.

encapsulation ppp
tx-queue-limit 26
no fair-queue

!--- This command is mandatory to enable FIFO queueing on
!--- the Serial interface.

ppp authentication chap

!--- This is an optional command needed for when you
!--- interface to a non-Cisco router.

ppp multilink
multilink-group 1
!
interface Serial1/0/3:0
no ip address
ip route-cache distributed

!--- This command is default and mandatory for distributed Multilink PPP.

encapsulation ppp
tx-queue-limit 26
no fair-queue

!--- This command is mandatory to enable FIFO queueing on
!--- the Serial interface.

ppp authentication chap

!--- This is an optional command needed for when you
```

```
!--- interface to a non-Cisco router.

ppp multilink
multilink-group 1
!
interface Serial1/0/4:0
no ip address
ip route-cache distributed

!--- This command is default and mandatory for distributed Multilink PPP.

encapsulation ppp
tx-queue-limit 26
no fair-queue

!--- This command is mandatory to enable FIFO queueing on
!--- the Serial interface.

ppp authentication chap

!--- This is an optional command needed for when you
!--- interface to a non-Cisco router.

ppp multilink
multilink-group 1
!
interface Serial1/0/5:0
no ip address
ip route-cache distributed

!--- This command is default and mandatory for distributed Multilink PPP.

encapsulation ppp
tx-queue-limit 26
no fair-queue

!--- This command is mandatory to enable FIFO queueing on
!--- the Serial interface.

ppp authentication chap

!--- This is an optional command needed for when you
!--- interface to a non-Cisco router.

ppp multilink
multilink-group 1
!
interface Serial1/0/6:0
no ip address
ip route-cache distributed

!--- This command is default and mandatory for distributed Multilink PPP.

encapsulation ppp
tx-queue-limit 26
no fair-queue

!--- This command is mandatory to enable FIFO queueing on
!--- the Serial interface.

ppp authentication chap

!--- This is an optional command needed for when you
!--- interface to a non-Cisco router.

ppp multilink
```

```

multilink-group 1
!
interface Serial1/0/7:0
no ip address
ip route-cache distributed

!--- This command is default and mandatory for distributed Multilink PPP.

encapsulation ppp
tx-queue-limit 26
no fair-queue

!--- This command is mandatory to enable FIFO queueing on
!--- the Serial interface.

ppp authentication chap

!--- This is an optional command needed for when you
!--- interface to a non-Cisco router.

ppp multilink
multilink-group 1
!
interface Ethernet1/1/0
ip address 10.10.20.1 255.255.255.0
no cdp enable
!
ip classless
ip route 10.10.30.0 255.255.255.0 10.10.10.2
no ip http server
!
!
line con 0
exec-timeout 0 0
line aux 0
line vty 0 4
exec-timeout 0 0
password <password>
login
!
end

```

Cisco 7206

```

version 12.1
service timestamps debug datetime msec
service timestamps log datetime msec
no service password-encryption
!
hostname bob
!
enable password <password>
!
username diana password 0 mlppp

!--- An optional CHAP secret shared with the remote router.

!
!
!
ip subnet-zero
!
!
controller E1 3/0
clock source internal

```

```
channel-group 0 timeslots 1-31

!--- You must assign all timeslots to one channel-group.

!
controller E1 3/1
clock source internal

!--- This command is only required when you provide master clock
!--- to the remote router.

channel-group 0 timeslots 1-31

!--- You must assign all timeslots to one channel-group.

!
controller E1 3/2
clock source internal

!--- This command is only required when you provide master clock
!--- to the remote router.

channel-group 0 timeslots 1-31

!--- You must assign all timeslots to one channel-group.

!
controller E1 3/3
clock source internal

!--- This command is only required when you provide master clock
!--- to the remote router.

channel-group 0 timeslots 1-31

!--- You must assign all timeslots to one channel-group.

!
controller E1 3/4
clock source internal

!--- This command is only required when you provide master clock
!--- to the remote router.

channel-group 0 timeslots 1-31

!--- You must assign all timeslots to one channel-group.

!
controller E1 3/5
clock source internal

!--- This command is only required when you provide master clock
!--- to the remote router.

channel-group 0 timeslots 1-31

!--- You must assign all timeslots to one channel-group.

!
controller E1 3/6
clock source internal

!--- This command is only required when you provide master clock
!--- to the remote router.
```

```
channel-group 0 timeslots 1-31

!--- You must assign all timeslots to one channel-group.

!
controller E1 3/7
clock source internal

!--- This command is only required when you provide master clock
!--- to the remote router.

channel-group 0 timeslots 1-31

!--- You must assign all timeslots to one channel-group.

!
!
!
!
!
interface Multilink1
ip address 10.10.10.2 255.255.255.0
ppp multilink
no ppp multilink fragmentation

!--- This command is optional to reduce CPU load.

multilink-group 1
!
interface FastEthernet0/0
ip address 10.10.30.1 255.255.255.0
no ip route-cache
no ip mroute-cache
half-duplex
no cdp enable
!
interface Serial3/0:0
no ip address
encapsulation ppp
no fair-queue

!--- This command is mandatory to enable FIFO queueing on
!--- the Serial interface.

ppp authentication chap

!--- This is an optional command needed for when you
!--- interface to a non-Cisco router.

ppp multilink
multilink-group 1
!
interface Serial3/1:0
no ip address
encapsulation ppp
no fair-queue

!--- This command is mandatory to enable FIFO queueing on
!--- the Serial interface.

ppp authentication chap

!--- This is an optional command needed for when you
!--- interface to a non-Cisco router.

ppp multilink
```

```
multilink-group 1
!
interface Serial3/2:0
  no ip address
  encapsulation ppp
  no fair-queue

!--- This command is mandatory to enable FIFO queueing on
!--- the Serial interface.

ppp authentication chap

!--- This is an optional command needed for when you
!--- interface to a non-Cisco router.

ppp multilink
multilink-group 1
!
interface Serial3/3:0
  no ip address
  encapsulation ppp
  no fair-queue

!--- This command is mandatory to enable FIFO queueing on
!--- the Serial interface.

ppp authentication chap

!--- This is an optional command needed for when you
!--- interface to a non-Cisco router.

ppp multilink
multilink-group 1
!
interface Serial3/4:0
  no ip address
  encapsulation ppp
  no fair-queue

!--- This command is mandatory to enable FIFO queueing on
!--- the Serial interface.

ppp authentication chap

!--- This is an optional command needed for when you
!--- interface to a non-Cisco router.

ppp multilink
multilink-group 1
!
interface Serial3/5:0
  no ip address
  encapsulation ppp
  no fair-queue

!--- This command is mandatory to enable FIFO queueing on
!--- the Serial interface.

ppp authentication chap

!--- This is an optional command needed for when you
!--- interface to a non-Cisco router.

ppp multilink
multilink-group 1
!
```

```

interface Serial3/6:0
  no ip address
  encapsulation ppp
  no fair-queue

  !--- This command is mandatory to enable FIFO queueing on
  !--- the Serial interface.

  ppp authentication chap

  !--- This is an optional command needed for when you
  !--- interface to a non-Cisco router.

  ppp multilink
  multilink-group 1
  !
interface Serial3/7:0
  no ip address
  encapsulation ppp
  no fair-queue

  !--- This command is mandatory to enable FIFO queueing on
  !--- the Serial interface.

  ppp authentication chap

  !--- This is an optional command needed for when you
  !--- interface to a non-Cisco router.

  ppp multilink
  multilink-group 1
  !
ip classless
ip route 10.10.20.0. 255.255.255.0 10.10.10.1
no ip http server
!
!
line con 0
  exec-timeout 0 0
line aux 0
line vty 0 4
  exec-timeout 0 0
  password <password>
  login
!
end

```

E1 Links with No G.704 Framing

Cisco 7505

```

version 12.1
service timestamps debug datetime msec
service timestamps log datetime msec
no service password-encryption
!
hostname diana
!
enable password <password>
!
!
!
!
ip subnet-zero

```

```
ip cef distributed

!--- This command is mandatory for distributed Multilink PPP.

no ip domain-lookup
!
!
controller E1 0/1/0
channel-group 0 unframed
!
controller E1 0/1/1
channel-group 0 unframed
!
controller E1 0/1/2
channel-group 0 unframed
!
controller E1 0/1/3
channel-group 0 unframed
!
controller E1 0/1/4
channel-group 0 unframed
!
controller E1 0/1/5
channel-group 0 unframed
!
controller E1 0/1/6
channel-group 0 unframed
!
controller E1 0/1/7
channel-group 0 unframed
!
!
!
interface Multilink1
ip address 10.10.10.1 255.255.255.0
no cdp enable
ppp multilink
no ppp multilink fragmentation

!--- This is an optional command to reduce CPU load.

multilink-group 1
!
interface Serial0/1/0:0
no ip address
ip route-cache distributed

!--- This command is default and mandatory for distributed Multilink PPP.

encapsulation ppp
tx-queue-limit 26
no fair-queue

!--- This command is mandatory to enable FIFO queueing on
!--- the Serial interface.

ppp multilink
multilink-group 1
!
interface Serial0/1/1:0
no ip address
ip route-cache distributed

!--- This command is default and mandatory for distributed Multilink PPP.

encapsulation ppp
```

```
tx-queue-limit 26
no fair-queue
```

```
!--- This command is mandatory to enable FIFO queueing on
!--- the Serial interface.
```

```
ppp multilink
multilink-group 1
!
```

```
interface Serial0/1/2:0
no ip address
ip route-cache distributed
```

```
!--- This command is default and mandatory for distributed Multilink PPP.
```

```
encapsulation ppp
tx-queue-limit 26
no fair-queue
```

```
!--- This command is mandatory to enable FIFO queueing on
!--- the Serial interface.
```

```
ppp multilink
multilink-group 1
!
```

```
interface Serial0/1/3:0
no ip address
ip route-cache distributed
```

```
!--- This command is default and mandatory for distributed Multilink PPP.
```

```
encapsulation ppp
tx-queue-limit 26
no fair-queue
```

```
!--- This command is mandatory to enable FIFO queueing on
!--- the Serial interface.
```

```
ppp multilink
multilink-group 1
!
```

```
interface Serial0/1/4:0
no ip address
ip route-cache distributed
```

```
!--- This command is default and mandatory for distributed Multilink PPP.
```

```
encapsulation ppp
tx-queue-limit 26
no fair-queue
```

```
!--- This command is mandatory to enable FIFO queueing on
!--- the Serial interface.
```

```
ppp multilink
multilink-group 1
!
```

```
interface Serial0/1/5:0
no ip address
ip route-cache distributed
```

```
!--- This command is default and mandatory for distributed Multilink PPP.
```

```
encapsulation ppp
tx-queue-limit 26
no fair-queue
```

```
!--- This command is mandatory to enable FIFO queueing on  
!--- the Serial interface.
```

```
ppp multilink  
multilink-group 1  
!  
interface Serial0/1/6:0  
no ip address  
ip route-cache distributed
```

```
!--- This command is default and mandatory for distributed Multilink PPP.
```

```
encapsulation ppp  
tx-queue-limit 26  
no fair-queue
```

```
!--- This command is mandatory to enable FIFO queueing on  
!--- the Serial interface.
```

```
ppp multilink  
multilink-group 1  
!  
interface Serial0/1/7:0  
no ip address  
ip route-cache distributed
```

```
!--- This command is default and mandatory for distributed Multilink PPP.
```

```
encapsulation ppp  
tx-queue-limit 26  
no fair-queue
```

```
!--- This command is mandatory to enable FIFO queueing on  
!--- the Serial interface.
```

```
ppp multilink  
multilink-group 1  
!  
interface Ethernet1/1/0  
ip address 10.10.20.1 255.255.255.0  
no cdp enable  
!  
ip classless  
ip route 10.10.30.0 255.255.255.0 10.10.10.2  
no ip http server  
!  
!  
line con 0  
exec-timeout 0 0  
line aux 0  
line vty 0 4  
exec-timeout 0 0  
password <password>  
login  
!  
end
```

Cisco 7206

```
version 12.1  
service timestamps debug datetime msec  
service timestamps log datetime msec  
no service password-encryption  
!
```

```
hostname bob
!
enable password <password>
!
!
!
!
!
ip subnet-zero

!
controller E1 3/0
  clock source internal

  !--- This command is only required when you provide master clock
!--- to the remote router.

  channel-group 0 unframed
!
controller E1 3/1
  clock source internal

  !--- This command is only required when you provide master clock
!--- to the remote router.

  channel-group 0 unframed
!
controller E1 3/2
  clock source internal

  !--- This command is only required when you provide master clock
!--- to the remote router.

  channel-group 0 unframed
!
controller E1 3/3
  clock source internal

  !--- This command is only required when you provide master clock
!--- to the remote router.

  channel-group 0 unframed
!
controller E1 3/4
  clock source internal

  !--- This command is only required when you provide master clock
!--- to the remote router.

  channel-group 0 unframed
!
controller E1 3/5
  clock source internal

  !--- This command is only required when you provide master clock
!--- to the remote router.

  channel-group 0 unframed
!
controller E1 3/6
  clock source internal

  !--- This command is only required when you provide master clock
!--- to the remote router.

  channel-group 0 unframed
```

```
!  
controller E1 3/7  
  clock source internal  
  
  !--- This command is only required when you provide master clock  
  !--- to the remote router.  
  
  channel-group 0 unframed  
!  
!  
!  
!  
interface Multilink1  
  ip address 10.10.10.2 255.255.255.0  
  ppp multilink  
  no ppp multilink fragmentation  
  
  !--- This is an optional command to reduce CPU load.  
  
  multilink-group 1  
!  
interface FastEthernet0/0  
  ip address 10.10.30.1 255.255.255.0  
  no ip route-cache  
  no ip mroute-cache  
  half-duplex  
  no cdp enable  
!  
interface Serial3/0:0  
  no ip address  
  encapsulation ppp  
  no fair-queue  
  
  !--- This command is mandatory to enable FIFO queueing on  
  !--- the Serial interface.  
  
  ppp multilink  
  multilink-group 1  
!  
interface Serial3/1:0  
  no ip address  
  encapsulation ppp  
  no fair-queue  
  
  !--- This command is mandatory to enable FIFO queueing on  
  !--- the Serial interface.  
  
  ppp multilink  
  multilink-group 1  
!  
interface Serial3/2:0  
  no ip address  
  encapsulation ppp  
  no fair-queue  
  
  !--- This command is mandatory to enable FIFO queueing on  
  !--- the Serial interface.  
  
  ppp multilink  
  multilink-group 1  
!  
interface Serial3/3:0  
  no ip address  
  encapsulation ppp  
  no fair-queue
```

```
!--- This command is mandatory to enable FIFO queueing on
!--- the Serial interface.

ppp multilink
multilink-group 1
!
interface Serial3/4:0
no ip address
encapsulation ppp
no fair-queue

!--- This command is mandatory to enable FIFO queueing on
!--- the Serial interface.

ppp multilink
multilink-group 1
!
interface Serial3/5:0
no ip address
encapsulation ppp
no fair-queue

!--- This command is mandatory to enable FIFO queueing on
!--- the Serial interface.

ppp multilink
multilink-group 1
!
interface Serial3/6:0
no ip address
encapsulation ppp
no fair-queue

!--- This command is mandatory to enable FIFO queueing on
!--- the Serial interface.

ppp multilink
multilink-group 1
!
interface Serial3/7:0
no ip address
encapsulation ppp
no fair-queue

!--- This command is mandatory to enable FIFO queueing on
!--- the Serial interface.

ppp multilink
multilink-group 1
!
ip classless
ip route 10.10.20.0 255.255.255.0 10.10.10.1
no ip http server
!
!
line con 0
exec-timeout 0 0
line aux 0
line vty 0 4
exec-timeout 0 0
password <password>
login
!
end
```

Verify

This section provides information you can use to confirm your configuration works properly.

Certain **show** commands are supported by the Output Interpreter Tool (registered customers only), which allows you to view an analysis of **show** command output.

- **show ppp multilink** Shows all Multilink bundles together with all Multilink bundle members.
- **show interfaces multilink** Shows the status of the Multilink bundle.
- **show interfaces serial** Shows the status of each Multilink bundle member.
- **show controllers e1** Shows the status of each E1 link.

Troubleshoot

This section provides information you can use to troubleshoot your configuration.

Troubleshooting Procedure

This procedure is relevant to both configurations.

1. Verify the status of the Multilink interface with the **show interface multilink** command:
 - ◆ If the Multilink interface is down, then verify the status of all Multilink bundle members with the **show ppp multilink** command.
 - ◆ If the Multilink line protocol is down, then verify the Network Control Protocol (NCP) and Multilink PPP (MLP) messages with the **debug ppp negotiation** and **debug ppp multilink events** commands.
2. If a Multilink member is inactive, verify the status of the Serial interface with the **show interface serial** command:
 - ◆ If the Serial interface is down, verify the status of the corresponding E1 link with the **show controller e1** command.
 - ◆ If the Serial line protocol is down, verify the Link Control Protocol (LCP) and CHAP messages with the **debug ppp negotiation** and **debug ppp authentication** commands.

Troubleshooting Commands

Certain **show** commands are supported by the Output Interpreter Tool (registered customers only), which allows you to view an analysis of **show** command output.

Note: Refer to Important Information on Debug Commands before you issue **debug** commands.

- **show ppp multilink** Shows all Multilink bundles together with all Multilink bundle members.
- **show interfaces multilink** Shows the status of the Multilink bundle.
- **show interfaces serial** Shows the status of each Multilink bundle member.
- **show controllers e1** Shows the status of each E1 link.
- **debug ppp negotiation** Shows all LCP and NCP negotiation messages.
- **debug ppp authentication** (*Optional*) Shows all CHAP authentication messages.
- **debug ppp multilink events** Shows all MLP bundle events.

This output shows the troubleshooting commands on the Cisco 7505 for the first configuration example.

All eight E1 links are active:

```
diana#show ppp multilink
```

```
Multilink1, bundle name is bob
```

```
Bundle up for 00:05:35
```

```
Bundle is Distributed
```

```
0 lost fragments, 0 reordered, 0 unassigned
```

```
0 discarded, 0 lost received, 3/255 load
```

```
0x1226 received sequence, 0x1226 sent sequence
```

```
Member links: 8 active, 0 inactive (max not set, min not set)
```

```
Serial1/0/0:0, since 00:05:35, no frags rcvd
```

```
Serial1/0/1:0, since 00:05:35, no frags rcvd
```

```
Serial1/0/2:0, since 00:05:35, no frags rcvd
```

```
Serial1/0/3:0, since 00:05:35, no frags rcvd
```

```
Serial1/0/4:0, since 00:05:35, no frags rcvd
```

```
Serial1/0/5:0, since 00:05:35, no frags rcvd
```

```
Serial1/0/6:0, since 00:05:35, no frags rcvd
```

```
Serial1/0/7:0, since 00:05:35, no frags rcvd
```

```
diana#show interface multilink 1
```

```
Multilink1 is up, line protocol is up
```

```
Hardware is multilink group interface
```

```
Internet address is 10.10.10.1/24
```

```
MTU 1500 bytes, BW 15872 Kbit, DLY 100000 usec,
```

```
reliability 255/255, txload 3/255, rxload 3/255
```

```
Encapsulation PPP, loopback not set
```

```
Keepalive set (10 sec)
```

```
DTR is pulsed for 2 seconds on reset
```

```
LCP Open, multilink Open
```

```
Open: IPCP
```

```
Last input 00:00:00, output never, output hang never
```

```
Last clearing of "show interface" counters 00:06:39
```

```
Input queue: 1/75/0/0 (size/max/drops/flushes); Total output drops: 0
```

```
Queueing strategy: fifo
```

```
Output queue :0/40 (size/max)
```

```
5 minute input rate 241000 bits/sec, 28 packets/sec
```

```
5 minute output rate 241000 bits/sec, 28 packets/sec
```

```
6525 packets input, 9810620 bytes, 0 no buffer
```

```
Received 0 broadcasts, 0 runts, 0 giants, 0 throttles
```

```
0 input errors, 0 CRC, 0 frame, 0 overrun, 0 ignored, 0 abort
```

```
6526 packets output, 9796112 bytes, 0 underruns
```

```
0 output errors, 0 collisions, 0 interface resets
```

```
0 output buffer failures, 0 output buffers swapped out
```

```
0 carrier transitions
```

In this output, the E1 controller 3/0 on the Cisco 7206 is disabled, which causes the E1 controller 1/0/0 and Serial 1/0/0:0 on the Cisco 7505 to go down:

```
diana#
```

```
*Nov 23 12:52:54.167: %CONTROLLER-5-UPDOWN:
```

```
Controller E1 1/0/0, changed state to down
```

```
*Nov 23 12:52:56.171: %LINK-3-UPDOWN:
```

```
Interface Serial1/0/0:0, changed state to down
```

```
*Nov 23 12:52:57.171: %LINEPROTO-5-UPDOWN:
```

```
Line protocol on Interface Serial1/0/0:0, changed state to down
```

```
diana#show ppp multilink
```

```
Multilink1, bundle name is bob
```

```
Bundle up for 00:06:52
```

```
Bundle is Distributed
```

```
0 lost fragments, 0 reordered, 0 unassigned
```

```
0 discarded, 0 lost received, 1/255 load
```

```
0x269C received sequence, 0x269B sent sequence
```

```
Member links: 7 active, 1 inactive (max not set, min not set)
```

```
Serial1/0/1:0, since 00:06:52, no frags rcvd
Serial1/0/2:0, since 00:06:52, no frags rcvd
Serial1/0/3:0, since 00:06:52, no frags rcvd
Serial1/0/4:0, since 00:06:52, no frags rcvd
Serial1/0/5:0, since 00:06:52, no frags rcvd
Serial1/0/6:0, since 00:06:52, no frags rcvd
Serial1/0/7:0, since 00:06:52, no frags rcvd
Serial1/0/0:0 (inactive)
```

```
diana#show interface multilink 1
```

```
Multilink1 is up, line protocol is up
```

```
Hardware is multilink group interface
Internet address is 10.10.10.1/24
MTU 1500 bytes, BW 13888 Kbit, DLY 100000 usec,
    reliability 255/255, txload 6/255, rxload 6/255
Encapsulation PPP, loopback not set
Keepalive set (10 sec)
DTR is pulsed for 2 seconds on reset
LCP Open, multilink Open
Open: IPCP
Last input 00:00:00, output never, output hang never
Last clearing of "show interface" counters 00:07:47
Input queue: 0/75/0/0 (size/max/drops/flushes); Total output drops: 0
Queueing strategy: fifo
Output queue :0/40 (size/max)
5 minute input rate 367000 bits/sec, 40 packets/sec
5 minute output rate 367000 bits/sec, 40 packets/sec
 10899 packets input, 16389116 bytes, 0 no buffer
  Received 0 broadcasts, 0 runts, 0 giants, 0 throttles
  0 input errors, 0 CRC, 0 frame, 0 overrun, 0 ignored, 0 abort
 10901 packets output, 16367362 bytes, 0 underruns
  0 output errors, 0 collisions, 0 interface resets
  0 output buffer failures, 0 output buffers swapped out
  0 carrier transitions
```

```
diana#show interface serial 1/0/0:0
```

```
Serial1/0/0:0 is down, line protocol is down
```

```
Hardware is Multichannel E1
MTU 1500 bytes, BW 1984 Kbit, DLY 20000 usec,
    reliability 255/255, txload 41/255, rxload 41/255
Encapsulation PPP, crc 16, Data non-inverted
Keepalive set (10 sec)
LCP Closed, multilink Closed
Closed: CDPCP
Last input 00:00:15, output 00:00:17, output hang never
Last clearing of "show interface" counters 00:07:42
Input queue: 0/75/0/0 (size/max/drops/flushes); Total output drops: 0
Queueing strategy: fifo
Output queue :0/40 (size/max)
5 minute input rate 323000 bits/sec, 35 packets/sec
5 minute output rate 324000 bits/sec, 35 packets/sec
 9811 packets input, 14623345 bytes, 0 no buffer
  Received 0 broadcasts, 0 runts, 0 giants, 0 throttles
  0 input errors, 0 CRC, 0 frame, 0 overrun, 0 ignored, 0 abort
 9809 packets output, 14680161 bytes, 0 underruns
  0 output errors, 0 collisions, 1 interface resets
  0 output buffer failures, 0 output buffers swapped out
  2 carrier transitions alarm present
Timeslot(s) Used:1-31, subrate: 64Kb/s, transmit delay is 0 flags
Transmit queue length 26
```

```
diana#show controller e1
```

```
E1 1/0/0 is down.
```

```
Applique type is Channelized E1 - balanced
Transmitter is sending remote alarm.
Receiver is getting AIS.
```

```
Framing is CRC4, Line Code is HDB3, Clock Source is Line.
International Bit: 1, National Bits: 11111
Data in current interval (465 seconds elapsed):
  1 Line Code Violations, 1 Path Code Violations
  0 Slip Secs, 0 Fr Loss Secs, 1 Line Err Secs, 0 Degraded Mins
  0 Errored Secs, 0 Bursty Err Secs, 0 Severely Err Secs, 19 Unavail Secs
...
```

```
diana#debug ppp negotiation
PPP protocol negotiation debugging is on
```

```
diana#debug ppp authentication
PPP authentication debugging is on
```

```
diana#debug ppp multilink events
Multilink events debugging is on
```

In this output, the E1 controller 3/0 on the Cisco 7206 is enabled again.

```
diana#
*Nov 23 12:53:40.167: %CONTROLLER-5-UPDOWN:
Controller E1 1/0/0, changed state to up
*Nov 23 12:53:42.071: Sel1/0/0:0 LCP: I CONFREQ [Closed] id 34 len 26
*Nov 23 12:53:42.071: Sel1/0/0:0 LCP:   AuthProto CHAP (0x0305C22305)
*Nov 23 12:53:42.071: Sel1/0/0:0 LCP:   MagicNumber 0x10193C10 (0x050610193C10)
*Nov 23 12:53:42.071: Sel1/0/0:0 LCP:   MRRU 1524 (0x110405F4)
*Nov 23 12:53:42.071: Sel1/0/0:0 LCP:   EndpointDisc 1 Local (0x130701646F6469)
*Nov 23 12:53:42.071: Sel1/0/0:0 LCP: Lower layer not up, Fast Starting
*Nov 23 12:53:42.071: Sel1/0/0:0 PPP: Treating connection as a dedicated line
*Nov 23 12:53:42.071: Sel1/0/0:0 PPP: Phase is ESTABLISHING, Active Open
*Nov 23 12:53:42.071: Sel1/0/0:0 LCP: O CONFREQ [Closed] id 2 len 27
*Nov 23 12:53:42.071: Sel1/0/0:0 LCP:   AuthProto CHAP (0x0305C22305)
*Nov 23 12:53:42.071: Sel1/0/0:0 LCP:   MagicNumber 0x80248196 (0x050680248196)
*Nov 23 12:53:42.071: Sel1/0/0:0 LCP:   MRRU 1524 (0x110405F4)
*Nov 23 12:53:42.071: Sel1/0/0:0 LCP:   EndpointDisc 1 Local (0x1308016469616E61)
*Nov 23 12:53:42.071: Sel1/0/0:0 LCP: O CONFACK [REQsent] id 34 len 26
*Nov 23 12:53:42.075: Sel1/0/0:0 LCP:   AuthProto CHAP (0x0305C22305)
*Nov 23 12:53:42.075: Sel1/0/0:0 LCP:   MagicNumber 0x10193C10 (0x050610193C10)
*Nov 23 12:53:42.075: Sel1/0/0:0 LCP:   MRRU 1524 (0x110405F4)
*Nov 23 12:53:42.075: Sel1/0/0:0 LCP:   EndpointDisc 1 Local (0x130701646F6469)
*Nov 23 12:53:42.075: Sel1/0/0:0 LCP: I CONFACK [ACKsent] id 2 len 27
*Nov 23 12:53:42.075: Sel1/0/0:0 LCP:   AuthProto CHAP (0x0305C22305)
*Nov 23 12:53:42.075: Sel1/0/0:0 LCP:   MagicNumber 0x80248196 (0x050680248196)
*Nov 23 12:53:42.075: Sel1/0/0:0 LCP:   MRRU 1524 (0x110405F4)
*Nov 23 12:53:42.075: Sel1/0/0:0 LCP:   EndpointDisc 1 Local (0x1308016469616E61)
*Nov 23 12:53:42.075: Sel1/0/0:0 LCP: State is Open
*Nov 23 12:53:42.079: Sel1/0/0:0 PPP: Phase is AUTHENTICATING, by both
*Nov 23 12:53:42.079: Sel1/0/0:0 CHAP: O CHALLENGE id 2 len 26 from "diana"
*Nov 23 12:53:42.079: Sel1/0/0:0 CHAP: I CHALLENGE id 4 len 25 from "bob"
*Nov 23 12:53:42.079: Sel1/0/0:0 CHAP: O RESPONSE id 4 len 26 from "diana"
*Nov 23 12:53:42.079: %LINK-3-UPDOWN: Interface Serial1/0/0:0, changed state to up
*Nov 23 12:53:42.083: Sel1/0/0:0 CHAP: I RESPONSE id 2 len 25 from "bob"
*Nov 23 12:53:42.083: Sel1/0/0:0 CHAP: I SUCCESS id 4 len 4
*Nov 23 12:53:42.083: Sel1/0/0:0 CHAP: O SUCCESS id 2 len 4
*Nov 23 12:53:42.087: Sel1/0/0:0 MLP: Request add link to bundle
*Nov 23 12:53:42.087: Sel1/0/0:0 PPP: Phase is VIRTUALIZED
*Nov 23 12:53:42.087: Sel1/0/0:0 MLP: Adding link to bundle
*Nov 23 12:53:42.087: Mul MLP: Added link Sel1/0/0:0 to bundle bob
*Nov 23 12:53:43.087: %LINEPROTO-5-UPDOWN:
Line protocol on Interface Serial1/0/0:0, changed state to up
```

```
diana#show ppp multilink
Multilink1, bundle name is bob
  Bundle up for 00:07:46
  Bundle is Distributed
  0 lost fragments, 0 reordered, 0 unassigned
```

```
0 discarded, 0 lost received, 7/255 load
0x35BF received sequence, 0x35BE sent sequence
Member links: 8 active, 0 inactive (max not set, min not set)
  Serial1/0/1:0, since 00:07:46, no frags rcvd
  Serial1/0/2:0, since 00:07:46, no frags rcvd
  Serial1/0/3:0, since 00:07:46, no frags rcvd
  Serial1/0/4:0, since 00:07:46, no frags rcvd
  Serial1/0/5:0, since 00:07:46, no frags rcvd
  Serial1/0/6:0, since 00:07:46, no frags rcvd
  Serial1/0/7:0, since 00:07:46, no frags rcvd
  Serial1/0/0:0, since 00:00:13, no frags rcvd
```

```
diana#show interface multilink 1
```

```
Multilink1 is up, line protocol is up
```

```
Hardware is multilink group interface
Internet address is 10.10.10.1/24
MTU 1500 bytes, BW 15872 Kbit, DLY 100000 usec,
  reliability 255/255, txload 7/255, rxload 7/255
Encapsulation PPP, loopback not set
Keepalive set (10 sec)
DTR is pulsed for 2 seconds on reset
LCP Open, multilink Open
Open: IPCP
Last input 00:00:00, output never, output hang never
Last clearing of "show interface" counters 00:08:32
Input queue: 1/75/0/0 (size/max/drops/flushes); Total output drops: 0
Queueing strategy: fifo
Output queue :0/40 (size/max)
5 minute input rate 443000 bits/sec, 49 packets/sec
5 minute output rate 443000 bits/sec, 49 packets/sec
  14098 packets input, 21200412 bytes, 0 no buffer
  Received 0 broadcasts, 0 runts, 0 giants, 0 throttles
  0 input errors, 0 CRC, 0 frame, 0 overrun, 0 ignored, 0 abort
  14099 packets output, 21170758 bytes, 0 underruns
  0 output errors, 0 collisions, 0 interface resets
  0 output buffer failures, 0 output buffers swapped out
  0 carrier transitions
```

```
diana#show interface serial 1/0/0:0
```

```
Serial1/0/0:0 is up, line protocol is up
```

```
Hardware is Multichannel E1
MTU 1500 bytes, BW 1984 Kbit, DLY 20000 usec,
  reliability 255/255, txload 32/255, rxload 32/255
Encapsulation PPP, crc 16, Data non-inverted
Keepalive set (10 sec)
LCP Open, multilink Open
Last input 00:00:02, output 00:00:02, output hang never
Last clearing of "show interface" counters 00:08:39
Input queue: 0/75/0/0 (size/max/drops/flushes); Total output drops: 0
Queueing strategy: fifo
Output queue :0/40 (size/max)
5 minute input rate 253000 bits/sec, 24 packets/sec
5 minute output rate 254000 bits/sec, 24 packets/sec
  9821 packets input, 14623552 bytes, 0 no buffer
  Received 0 broadcasts, 0 runts, 0 giants, 0 throttles
  0 input errors, 0 CRC, 0 frame, 0 overrun, 0 ignored, 0 abort
  9819 packets output, 14680370 bytes, 0 underruns
  0 output errors, 0 collisions, 1 interface resets
  0 output buffer failures, 0 output buffers swapped out
  3 carrier transitions no alarm present
Timeslot(s) Used:1-31, subrate: 64Kb/s, transmit delay is 0 flags
Transmit queue length 26
```

```
diana#show controller e1
```

```
E1 1/0/0 is up.
```

```
Applique type is Channelized E1 - balanced
```

No alarms detected.

Framing is CRC4, Line Code is HDB3, Clock Source is Line.

International Bit: 1, National Bits: 11111

Data in current interval (519 seconds elapsed):

1 Line Code Violations, 1 Path Code Violations

0 Slip Secs, 0 Fr Loss Secs, 1 Line Err Secs, 0 Degraded Mins

0 Errored Secs, 0 Bursty Err Secs, 0 Severely Err Secs, 37 Unavail Secs

...

Related Information

- [Distributed Multilink Point-to-Point Protocol for Cisco 7500 Series Routers](#)
- [Criteria for Naming Multilink PPP Bundles](#)
- [Dial Technology Support Pages](#)
- [Technical Support & Documentation – Cisco Systems](#)

[Contacts & Feedback](#) | [Help](#) | [Site Map](#)

© 2008 – 2009 Cisco Systems, Inc. All rights reserved. [Terms & Conditions](#) | [Privacy Statement](#) | [Cookie Policy](#) | [Trademarks of Cisco Systems, Inc.](#)

Updated: Jan 29, 2008

Document ID: 11044
