

BTM CGW Dscd Pkts Errors

Document ID: 10850

Introduction

Prerequisites

Requirements

Components Used

Conventions

Error Definition

Error Example

Troubleshooting

Related Information

Introduction

This document discusses the BTM CGW Dscd Pkts error and provides steps on how to troubleshoot this error message.

Prerequisites

Requirements

There are no specific requirements for this document.

Components Used

This error applies to the IGX Broadband Trunk Module (BTM) with E1, E2, E3, and T3 backcards.

The information in this document was created from the devices in a specific lab environment. All of the devices used in this document started with a cleared (default) configuration. If your network is live, make sure that you understand the potential impact of any command.

Conventions

For more information on document conventions, refer to the Cisco Technical Tips Conventions.

Error Definition

CGW Dscd Pkts errors indicate that the complex gateway (CGW) function of the BTM has discarded a FastPacket in the egress direction. The egress direction is from the BTM to the network. CGW is not a type of traffic. CGW generates legacy StrataCom Trunk Interface (STI) or standard ATM Adaptation Layer-5 (AAL5) cell payloads out of FastPackets. The BTM trunk card can convert FastPackets into AAL5 ATM cells. CGW Dscd Pkts errors occur because the cyclic redundancy check (CRC-16) of the frame segment contained in the FastPacket is corrupt. This is typically caused by bit errors that have corrupted the payload of FastPackets on trunks they have traversed. Other reasons for this problem include:

- Inadequate node grounding
- Faulty hardware

The BTM supports CGW connections with the limitation that CGW connections will not pass data that is routed across a BTM trunk that has been configured for simple addressing mode (SAM). CGW connections will pass data when routed across BTM trunks that are configured for BPX addressing mode (BAM) or cloud addressing mode (CAM). The CGW function is determined strictly by endpoint cards. ATM-to-FR connections always use CGW. Most FR-to-FR connections use CGW, except for FRM-to-FRM connections, which use simple gateway.

Error Example

The likely location of equipment errors is highlighted in yellow.

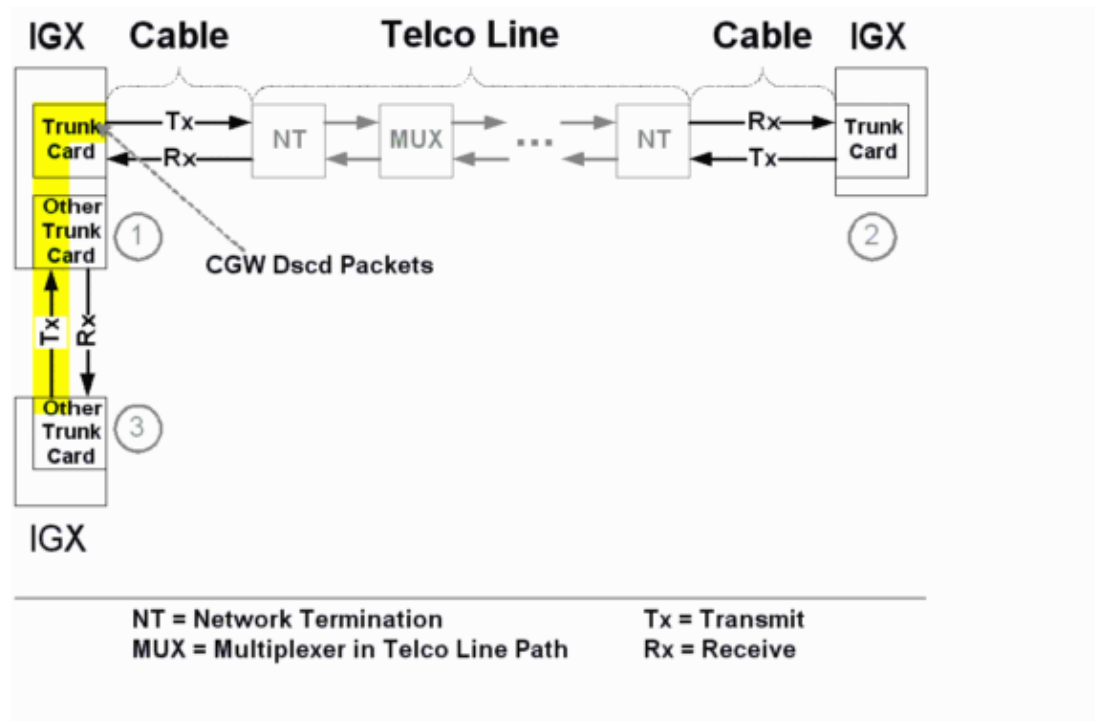

Troubleshooting

The following steps show how to troubleshoot the BTM CGW Dscd Pkts error.

1. Identify FR or Frame Forwarding (FF) connections that terminate on the BTM trunk and increment CGW Dscd Pkts errors.
2. Identify the trunk further upstream that could be causing the FastPacket payload to corrupt.
 - a. Using the SuperUser-level **dsprkcons** command, identify the node displayed under Src Node.
 - b. Issue the **vt** command to initiate a virtual session with the node displayed under Src Node.
 - c. At the Src Node, issue the **dsprts** command until you find a connection that traverses the BTM trunk that is incrementing CGW Dscd Pkts errors.
 - d. Cut and paste the matching connections and paths into a text file.
3. Look through the list and check each connection end point by issuing the **clrchstats** command.
4. Issue the SuperUser-level **dspchstats** command to view discarded frames from the network.
5. In the error example above, the **dsprkcons** command was issued on the BTM trunk in IGX1. Assume this displays IGX2 as a Src Node. **VT** to IGX2 and look through all connections displayed after you issue the **dsprts** command to find a FR or FF connection that traverses the BTM trunk in IGX1. This may not be practical if there is a very large number of connections.

6. Once such a connection has been identified, use the **clrchstats** and **dspehstats** commands to identify connections that are discarding frames from the network.
7. If there are discarded frames on a connection, refer to the route to see which trunks they have crossed before traversing the BTM trunk in IGX1.
8. If the connection terminates on IGX3 and traverses the Other Trunk Card shown in the above graphic, then investigate the trunk as the cause of CGW Dscd Pkts errors.
9. Check dsprkerrs on IGX1 to see if there are indications that trunk quality is deteriorating. Troubleshoot those trunk errors first.
10. In networks with a few trunks, issue the **dsprkerrs** command on the trunks in the proximity of the node that shows CGW Dscd Pkts errors to check for trunk errors. The trunk that causes payload corruption might be located multiple hops away from the BTM trunk that is incrementing CGW Dscd Pkts errors.
11. Make sure that the IGX chassis is properly grounded. Incorrect or insufficient grounding can cause problems. Refer to Power and Grounding for more information on grounding a chassis.

If the problem persists after performing the troubleshooting steps, please contact the Cisco Systems Technical Assistance Center (TAC) at (800) 553–24HR, (408) 526–7209, the Cisco TAC web site, or send e–mail to tac@cisco.com.

Related Information

- [WAN Switching Network Synchronization Fundamentals](#)
- [IGX 8400 BTM Trunk Error Troubleshooting and Definitions](#)
- [International Telephony Union \(ITU\) Recommendation G.704](#)
- [Cisco WAN Switching Solutions – Cisco Documentation](#)
- [Guide to New Names and Colors for WAN Switching Products](#)
- [Technical Support – Cisco Systems](#)

[Contacts & Feedback](#) | [Help](#) | [Site Map](#)

© 2009 – 2010 Cisco Systems, Inc. All rights reserved. [Terms & Conditions](#) | [Privacy Statement](#) | [Cookie Policy](#) | [Trademarks of Cisco Systems, Inc.](#)

Updated: Oct 04, 2005

Document ID: 10850
