



CHAPTER 24

Configuring Dynamic ARP Inspection

This chapter describes how to configure dynamic Address Resolution Protocol inspection (dynamic ARP inspection) on the Catalyst 3750-E or 3560-E switch. This feature helps prevent malicious attacks on the switch by not relaying invalid ARP requests and responses to other ports in the same VLAN. Unless otherwise noted, the term *switch* refers to a Catalyst 3750-E or 3560-E standalone switch and to a Catalyst 3750-E switch stack.



Note

For complete syntax and usage information for the commands used in this chapter, see the command reference for this release.

This chapter consists of these sections:

- [Understanding Dynamic ARP Inspection, page 24-1](#)
- [Configuring Dynamic ARP Inspection, page 24-5](#)
- [Displaying Dynamic ARP Inspection Information, page 24-15](#)

Understanding Dynamic ARP Inspection

ARP provides IP communication within a Layer 2 broadcast domain by mapping an IP address to a MAC address. For example, Host B wants to send information to Host A but does not have the MAC address of Host A in its ARP cache. Host B generates a broadcast message for all hosts within the broadcast domain to obtain the MAC address associated with the IP address of Host A. All hosts within the broadcast domain receive the ARP request, and Host A responds with its MAC address. However, because ARP allows a gratuitous reply from a host even if an ARP request was not received, an ARP spoofing attack and the poisoning of ARP caches can occur. After the attack, all traffic from the device under attack flows through the attacker's computer and then to the router, switch, or host.

A malicious user can attack hosts, switches, and routers connected to your Layer 2 network by poisoning the ARP caches of systems connected to the subnet and by intercepting traffic intended for other hosts on the subnet. [Figure 24-1](#) shows an example of ARP cache poisoning.

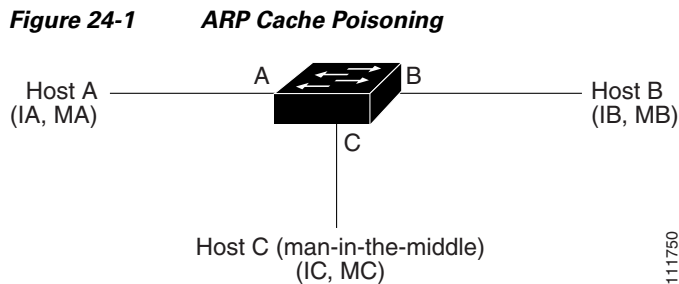

Hosts A, B, and C are connected to the switch on interfaces A, B and C, all of which are on the same subnet. Their IP and MAC addresses are shown in parentheses; for example, Host A uses IP address IA and MAC address MA. When Host A needs to communicate to Host B at the IP layer, it broadcasts an ARP request for the MAC address associated with IP address IB. When the switch and Host B receive the ARP request, they populate their ARP caches with an ARP binding for a host with the IP address IA and a MAC address MA; for example, IP address IA is bound to MAC address MA. When Host B responds, the switch and Host A populate their ARP caches with a binding for a host with the IP address IB and the MAC address MB.

Host C can poison the ARP caches of the switch, Host A, and Host B by broadcasting forged ARP responses with bindings for a host with an IP address of IA (or IB) and a MAC address of MC. Hosts with poisoned ARP caches use the MAC address MC as the destination MAC address for traffic intended for IA or IB. This means that Host C intercepts that traffic. Because Host C knows the true MAC addresses associated with IA and IB, it can forward the intercepted traffic to those hosts by using the correct MAC address as the destination. Host C has inserted itself into the traffic stream from Host A to Host B, the classic *man-in-the-middle* attack.

Dynamic ARP inspection is a security feature that validates ARP packets in a network. It intercepts, logs, and discards ARP packets with invalid IP-to-MAC address bindings. This capability protects the network from certain man-in-the-middle attacks.

Dynamic ARP inspection ensures that only valid ARP requests and responses are relayed. The switch performs these activities:

- Intercepts all ARP requests and responses on untrusted ports
- Verifies that each of these intercepted packets has a valid IP-to-MAC address binding before updating the local ARP cache or before forwarding the packet to the appropriate destination
- Drops invalid ARP packets

Dynamic ARP inspection determines the validity of an ARP packet based on valid IP-to-MAC address bindings stored in a trusted database, the DHCP snooping binding database. This database is built by DHCP snooping if DHCP snooping is enabled on the VLANs and on the switch. If the ARP packet is received on a trusted interface, the switch forwards the packet without any checks. On untrusted interfaces, the switch forwards the packet only if it is valid.

You enable dynamic ARP inspection on a per-VLAN basis by using the **ip arp inspection vlan *vlan-range*** global configuration command. For configuration information, see the “[Configuring Dynamic ARP Inspection in DHCP Environments](#)” section on page 24-7.

In non-DHCP environments, dynamic ARP inspection can validate ARP packets against user-configured ARP access control lists (ACLs) for hosts with statically configured IP addresses. You define an ARP ACL by using the **arp access-list *acl-name*** global configuration command. For configuration information, see the “[Configuring ARP ACLs for Non-DHCP Environments](#)” section on page 24-8. The switch logs dropped packets. For more information about the log buffer, see the “[Logging of Dropped Packets](#)” section on page 24-5.

You can configure dynamic ARP inspection to drop ARP packets when the IP addresses in the packets are invalid or when the MAC addresses in the body of the ARP packets do not match the addresses specified in the Ethernet header. Use the **ip arp inspection validate** {[src-mac] [dst-mac] [ip]} global configuration command. For more information, see the “Performing Validation Checks” section on page 24-12.

Interface Trust States and Network Security

Dynamic ARP inspection associates a trust state with each interface on the switch. Packets arriving on trusted interfaces bypass all dynamic ARP inspection validation checks, and those arriving on untrusted interfaces undergo the dynamic ARP inspection validation process.

In a typical network configuration, you configure all switch ports connected to host ports as untrusted and configure all switch ports connected to switches as trusted. With this configuration, all ARP packets entering the network from a given switch bypass the security check. No other validation is needed at any other place in the VLAN or in the network. You configure the trust setting by using the **ip arp inspection trust** interface configuration command.



Caution

Use the trust state configuration carefully. Configuring interfaces as untrusted when they should be trusted can result in a loss of connectivity.

In [Figure 24-2](#), assume that both Switch A and Switch B are running dynamic ARP inspection on the VLAN that includes Host 1 and Host 2. If Host 1 and Host 2 acquire their IP addresses from the DHCP server connected to Switch A, only Switch A binds the IP-to-MAC address of Host 1. Therefore, if the interface between Switch A and Switch B is untrusted, the ARP packets from Host 1 are dropped by Switch B. Connectivity between Host 1 and Host 2 is lost.

Figure 24-2 ARP Packet Validation on a VLAN Enabled for Dynamic ARP Inspection

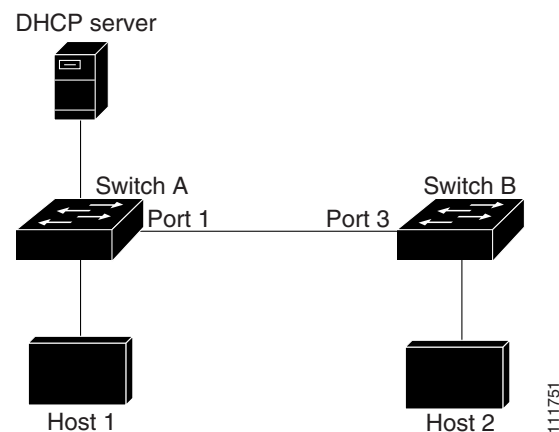

Configuring interfaces to be trusted when they are actually untrusted leaves a security hole in the network. If Switch A is not running dynamic ARP inspection, Host 1 can easily poison the ARP cache of Switch B (and Host 2, if the link between the switches is configured as trusted). This condition can occur even though Switch B is running dynamic ARP inspection.

Dynamic ARP inspection ensures that hosts (on untrusted interfaces) connected to a switch running dynamic ARP inspection do not poison the ARP caches of other hosts in the network. However, dynamic ARP inspection does not prevent hosts in other portions of the network from poisoning the caches of the hosts that are connected to a switch running dynamic ARP inspection.

In cases in which some switches in a VLAN run dynamic ARP inspection and other switches do not, configure the interfaces connecting such switches as untrusted. However, to validate the bindings of packets from nondynamic ARP inspection switches, configure the switch running dynamic ARP inspection with ARP ACLs. When you cannot determine such bindings, at Layer 3, isolate switches running dynamic ARP inspection from switches not running dynamic ARP inspection switches. For configuration information, see the [“Configuring ARP ACLs for Non-DHCP Environments”](#) section on page 24-8.

**Note**

Depending on the setup of the DHCP server and the network, it might not be possible to validate a given ARP packet on all switches in the VLAN.

Rate Limiting of ARP Packets

The switch CPU performs dynamic ARP inspection validation checks; therefore, the number of incoming ARP packets is rate-limited to prevent a denial-of-service attack. By default, the rate for untrusted interfaces is 15 packets per second (pps). Trusted interfaces are not rate-limited. You can change this setting by using the **ip arp inspection limit** interface configuration command.

When the rate of incoming ARP packets exceeds the configured limit, the switch places the port in the error-disabled state. The port remains in that state until you intervene. You can use the **errdisable recovery** global configuration command to enable error disable recovery so that ports automatically emerge from this state after a specified timeout period.

**Note**

The rate limit for an EtherChannel is applied separately to each switch in a stack. For example, if a limit of 20 pps is configured on the EtherChannel, each switch with ports in the EtherChannel can carry up to 20 pps. If any switch exceeds the limit, the entire EtherChannel is placed into the error-disabled state.

For configuration information, see the [“Limiting the Rate of Incoming ARP Packets”](#) section on page 24-11.

Relative Priority of ARP ACLs and DHCP Snooping Entries

Dynamic ARP inspection uses the DHCP snooping binding database for the list of valid IP-to-MAC address bindings.

ARP ACLs take precedence over entries in the DHCP snooping binding database. The switch uses ACLs only if you configure them by using the **ip arp inspection filter vlan** global configuration command. The switch first compares ARP packets to user-configured ARP ACLs. If the ARP ACL denies the ARP packet, the switch also denies the packet even if a valid binding exists in the database populated by DHCP snooping.

Logging of Dropped Packets

When the switch drops a packet, it places an entry in the log buffer and then generates system messages on a rate-controlled basis. After the message is generated, the switch clears the entry from the log buffer. Each log entry contains flow information, such as the receiving VLAN, the port number, the source and destination IP addresses, and the source and destination MAC addresses.

You use the **ip arp inspection log-buffer** global configuration command to configure the number of entries in the buffer and the number of entries needed in the specified interval to generate system messages. You specify the type of packets that are logged by using the **ip arp inspection vlan logging** global configuration command. For configuration information, see the “[Configuring the Log Buffer](#)” section on page 24-13.

Configuring Dynamic ARP Inspection

These sections contain this configuration information:

- [Default Dynamic ARP Inspection Configuration, page 24-5](#)
- [Dynamic ARP Inspection Configuration Guidelines, page 24-6](#)
- [Configuring Dynamic ARP Inspection in DHCP Environments, page 24-7](#) (required in DHCP environments)
- [Configuring ARP ACLs for Non-DHCP Environments, page 24-8](#) (required in non-DHCP environments)
- [Limiting the Rate of Incoming ARP Packets, page 24-11](#) (optional)
- [Performing Validation Checks, page 24-12](#) (optional)
- [Configuring the Log Buffer, page 24-13](#) (optional)

Default Dynamic ARP Inspection Configuration

[Table 24-1](#) shows the default dynamic ARP inspection configuration.

Table 24-1 *Default Dynamic ARP Inspection Configuration*

Feature	Default Setting
Dynamic ARP inspection	Disabled on all VLANs.
Interface trust state	All interfaces are untrusted.
Rate limit of incoming ARP packets	The rate is 15 pps on untrusted interfaces, assuming that the network is a switched network with a host connecting to as many as 15 new hosts per second. The rate is unlimited on all trusted interfaces. The burst interval is 1 second.
ARP ACLs for non-DHCP environments	No ARP ACLs are defined.
Validation checks	No checks are performed.

Table 24-1 Default Dynamic ARP Inspection Configuration (continued)

Feature	Default Setting
Log buffer	When dynamic ARP inspection is enabled, all denied or dropped ARP packets are logged. The number of entries in the log is 32. The number of system messages is limited to 5 per second. The logging-rate interval is 1 second.
Per-VLAN logging	All denied or dropped ARP packets are logged.

Dynamic ARP Inspection Configuration Guidelines

These are the dynamic ARP inspection configuration guidelines:

- Dynamic ARP inspection is an ingress security feature; it does not perform any egress checking.
- Dynamic ARP inspection is not effective for hosts connected to switches that do not support dynamic ARP inspection or that do not have this feature enabled. Because man-in-the-middle attacks are limited to a single Layer 2 broadcast domain, separate the domain with dynamic ARP inspection checks from the one with no checking. This action secures the ARP caches of hosts in the domain enabled for dynamic ARP inspection.
- Dynamic ARP inspection depends on the entries in the DHCP snooping binding database to verify IP-to-MAC address bindings in incoming ARP requests and ARP responses. Make sure to enable DHCP snooping to permit ARP packets that have dynamically assigned IP addresses. For configuration information, see [Chapter 23, “Configuring DHCP Features and IP Source Guard.”](#)
When DHCP snooping is disabled or in non-DHCP environments, use ARP ACLs to permit or to deny packets.
- Dynamic ARP inspection is supported on access ports, trunk ports, EtherChannel ports, and private VLAN ports.



Note

Do not enable Dynamic ARP inspection on RSPAN VLANs. If Dynamic ARP inspection is enabled on RSPAN VLANs, Dynamic ARP inspection packets might not reach the RSPAN destination port.

- A physical port can join an EtherChannel port channel only when the trust state of the physical port and the channel port match. Otherwise, the physical port remains suspended in the port channel. A port channel inherits its trust state from the first physical port that joins the channel. Consequently, the trust state of the first physical port need not match the trust state of the channel.
Conversely, when you change the trust state on the port channel, the switch configures a new trust state on all the physical ports that comprise the channel.
- The rate limit is calculated separately on each switch in a switch stack. For a cross-stack EtherChannel, this means that the actual rate limit might be higher than the configured value. For example, if you set the rate limit to 30 pps on an EtherChannel that has one port on switch 1 and one port on switch 2, each port can receive packets at 29 pps without causing the EtherChannel to become error-disabled.

- The operating rate for the port channel is cumulative across all the physical ports within the channel. For example, if you configure the port channel with an ARP rate-limit of 400 pps, all the interfaces combined on the channel receive an aggregate 400 pps. The rate of incoming ARP packets on EtherChannel ports is equal to the sum of the incoming rate of packets from all the channel members. Configure the rate limit for EtherChannel ports only after examining the rate of incoming ARP packets on the channel-port members.

The rate of incoming packets on a physical port is checked against the port-channel configuration rather than the physical-ports configuration. The rate-limit configuration on a port channel is independent of the configuration on its physical ports.

If the EtherChannel receives more ARP packets than the configured rate, the channel (including all physical ports) is placed in the error-disabled state.

- Make sure to limit the rate of ARP packets on incoming trunk ports. Configure trunk ports with higher rates to reflect their aggregation and to handle packets across multiple dynamic ARP inspection-enabled VLANs. You also can use the **ip arp inspection limit none** interface configuration command to make the rate unlimited. A high rate-limit on one VLAN can cause a denial-of-service attack to other VLANs when the software places the port in the error-disabled state.
- When you enable dynamic ARP inspection on the switch, policers that were configured to police ARP traffic are no longer effective. The result is that all ARP traffic is sent to the CPU.

Configuring Dynamic ARP Inspection in DHCP Environments

This procedure shows how to configure dynamic ARP inspection when two switches support this feature. Host 1 is connected to Switch A, and Host 2 is connected to Switch B as shown in [Figure 24-2 on page 24-3](#). Both switches are running dynamic ARP inspection on VLAN 1 where the hosts are located. A DHCP server is connected to Switch A. Both hosts acquire their IP addresses from the same DHCP server. Therefore, Switch A has the bindings for Host 1 and Host 2, and Switch B has the binding for Host 2.



Note

Dynamic ARP inspection depends on the entries in the DHCP snooping binding database to verify IP-to-MAC address bindings in incoming ARP requests and ARP responses. Make sure to enable DHCP snooping to permit ARP packets that have dynamically assigned IP addresses. For configuration information, see [Chapter 23, “Configuring DHCP Features and IP Source Guard.”](#)

For information on how to configure dynamic ARP inspection when only one switch supports the feature, see the [“Configuring ARP ACLs for Non-DHCP Environments” section on page 24-8](#).

Beginning in privileged EXEC mode, follow these steps to configure dynamic ARP inspection. You must perform this procedure on both switches. This procedure is required.

	Command	Purpose
Step 1	show cdp neighbors	Verify the connection between the switches.
Step 2	configure terminal	Enter global configuration mode.

	Command	Purpose
Step 3	ip arp inspection vlan <i>vlan-range</i>	Enable dynamic ARP inspection on a per-VLAN basis. By default, dynamic ARP inspection is disabled on all VLANs. For <i>vlan-range</i> , specify a single VLAN identified by VLAN ID number, a range of VLANs separated by a hyphen, or a series of VLANs separated by a comma. The range is 1 to 4094. Specify the same VLAN ID for both switches.
Step 4	interface <i>interface-id</i>	Specify the interface connected to the other switch, and enter interface configuration mode.
Step 5	ip arp inspection trust	Configure the connection between the switches as trusted. By default, all interfaces are untrusted. The switch does not check ARP packets that it receives from the other switch on the trusted interface. It simply forwards the packets. For untrusted interfaces, the switch intercepts all ARP requests and responses. It verifies that the intercepted packets have valid IP-to-MAC address bindings before updating the local cache and before forwarding the packet to the appropriate destination. The switch drops invalid packets and logs them in the log buffer according to the logging configuration specified with the ip arp inspection vlan logging global configuration command. For more information, see the “ Configuring the Log Buffer ” section on page 24-13.
Step 6	end	Return to privileged EXEC mode.
Step 7	show ip arp inspection interfaces show ip arp inspection vlan <i>vlan-range</i>	Verify the dynamic ARP inspection configuration.
Step 8	show ip dhcp snooping binding	Verify the DHCP bindings.
Step 9	show ip arp inspection statistics vlan <i>vlan-range</i>	Check the dynamic ARP inspection statistics.
Step 10	copy running-config startup-config	(Optional) Save your entries in the configuration file.

To disable dynamic ARP inspection, use the **no ip arp inspection vlan** *vlan-range* global configuration command. To return the interfaces to an untrusted state, use the **no ip arp inspection trust** interface configuration command.

This example shows how to configure dynamic ARP inspection on Switch A in VLAN 1. You would perform a similar procedure on Switch B:

```
Switch(config)# ip arp inspection vlan 1
Switch(config)# interface gigabitethernet1/0/1
Switch(config-if)# ip arp inspection trust
```

Configuring ARP ACLs for Non-DHCP Environments

This procedure shows how to configure dynamic ARP inspection when Switch B shown in [Figure 24-2 on page 24-3](#) does not support dynamic ARP inspection or DHCP snooping.

If you configure port 1 on Switch A as trusted, a security hole is created because both Switch A and Host 1 could be attacked by either Switch B or Host 2. To prevent this possibility, you must configure port 1 on Switch A as untrusted. To permit ARP packets from Host 2, you must set up an ARP ACL and apply it to VLAN 1. If the IP address of Host 2 is not static (it is impossible to apply the ACL configuration on Switch A) you must separate Switch A from Switch B at Layer 3 and use a router to route packets between them.

Beginning in privileged EXEC mode, follow these steps to configure an ARP ACL on Switch A. This procedure is required in non-DHCP environments.

	Command	Purpose
Step 1	configure terminal	Enter global configuration mode.
Step 2	arp access-list <i>acl-name</i>	Define an ARP ACL, and enter ARP access-list configuration mode. By default, no ARP access lists are defined. Note At the end of the ARP access list, there is an implicit deny ip any mac any command.
Step 3	permit ip host <i>sender-ip</i> mac host <i>sender-mac</i> [log]	Permit ARP packets from the specified host (Host 2). <ul style="list-style-type: none"> • For <i>sender-ip</i>, enter the IP address of Host 2. • For <i>sender-mac</i>, enter the MAC address of Host 2. • (Optional) Specify log to log a packet in the log buffer when it matches the access control entry (ACE). Matches are logged if you also configure the matchlog keyword in the ip arp inspection vlan logging global configuration command. For more information, see the “Configuring the Log Buffer” section on page 24-13.
Step 4	exit	Return to global configuration mode.

	Command	Purpose
Step 5	ip arp inspection filter <i>arp-acl-name</i> vlan <i>vlan-range</i> [static]	<p>Apply the ARP ACL to the VLAN. By default, no defined ARP ACLs are applied to any VLAN.</p> <ul style="list-style-type: none"> For <i>arp-acl-name</i>, specify the name of the ACL created in Step 2. For <i>vlan-range</i>, specify the VLAN that the switches and hosts are in. You can specify a single VLAN identified by VLAN ID number, a range of VLANs separated by a hyphen, or a series of VLANs separated by a comma. The range is 1 to 4094. (Optional) Specify static to treat implicit denies in the ARP ACL as explicit denies and to drop packets that do not match any previous clauses in the ACL. DHCP bindings are not used. <p>If you do not specify this keyword, it means that there is no explicit deny in the ACL that denies the packet, and DHCP bindings determine whether a packet is permitted or denied if the packet does not match any clauses in the ACL.</p> <p>ARP packets containing only IP-to-MAC address bindings are compared against the ACL. Packets are permitted only if the access list permits them.</p>
Step 6	interface <i>interface-id</i>	Specify the Switch A interface that is connected to Switch B, and enter interface configuration mode.
Step 7	no ip arp inspection trust	<p>Configure the Switch A interface that is connected to Switch B as untrusted.</p> <p>By default, all interfaces are untrusted.</p> <p>For untrusted interfaces, the switch intercepts all ARP requests and responses. It verifies that the intercepted packets have valid IP-to-MAC address bindings before updating the local cache and before forwarding the packet to the appropriate destination. The switch drops invalid packets and logs them in the log buffer according to the logging configuration specified with the ip arp inspection vlan logging global configuration command. For more information, see the “Configuring the Log Buffer” section on page 24-13.</p>
Step 8	end	Return to privileged EXEC mode.
Step 9	show arp access-list [<i>acl-name</i>] show ip arp inspection vlan <i>vlan-range</i> show ip arp inspection interfaces	Verify your entries.
Step 10	copy running-config startup-config	(Optional) Save your entries in the configuration file.

To remove the ARP ACL, use the **no arp access-list** global configuration command. To remove the ARP ACL attached to a VLAN, use the **no ip arp inspection filter** *arp-acl-name* **vlan** *vlan-range* global configuration command.

This example shows how to configure an ARP ACL called *host2* on Switch A, to permit ARP packets from Host 2 (IP address 1.1.1.1 and MAC address 0001.0001.0001), to apply the ACL to VLAN 1, and to configure port 1 on Switch A as untrusted:

```
Switch(config)# arp access-list host2
Switch(config-arp-acl)# permit ip host 1.1.1.1 mac host 1.1.1
Switch(config-arp-acl)# exit
Switch(config)# ip arp inspection filter host2 vlan 1
Switch(config)# interface gigabitethernet1/0/1
Switch(config-if)# no ip arp inspection trust
```

Limiting the Rate of Incoming ARP Packets

The switch CPU performs dynamic ARP inspection validation checks; therefore, the number of incoming ARP packets is rate-limited to prevent a denial-of-service attack.

When the rate of incoming ARP packets exceeds the configured limit, the switch places the port in the error-disabled state. The port remains in that state until you enable error-disabled recovery so that ports automatically emerge from this state after a specified timeout period.



Note

Unless you configure a rate limit on an interface, changing the trust state of the interface also changes its rate limit to the default value for that trust state. After you configure the rate limit, the interface retains the rate limit even when its trust state is changed. If you enter the **no ip arp inspection limit** interface configuration command, the interface reverts to its default rate limit.

For configuration guidelines for rate limiting trunk ports and EtherChannel ports, see the [“Dynamic ARP Inspection Configuration Guidelines”](#) section on page 24-6.

Beginning in privileged EXEC mode, follow these steps to limit the rate of incoming ARP packets. This procedure is optional.

	Command	Purpose
Step 1	configure terminal	Enter global configuration mode.
Step 2	interface <i>interface-id</i>	Specify the interface to be rate-limited, and enter interface configuration mode.
Step 3	ip arp inspection limit { <i>rate pps</i> [<i>burst interval seconds</i>] none }	<p>Limit the rate of incoming ARP requests and responses on the interface. The default rate is 15 pps on untrusted interfaces and unlimited on trusted interfaces. The burst interval is 1 second.</p> <p>The keywords have these meanings:</p> <ul style="list-style-type: none"> For rate pps, specify an upper limit for the number of incoming packets processed per second. The range is 0 to 2048 pps. (Optional) For burst interval seconds, specify the consecutive interval in seconds, over which the interface is monitored for a high rate of ARP packets. The range is 1 to 15. For rate none, specify no upper limit for the rate of incoming ARP packets that can be processed.

	Command	Purpose
Step 4	exit	Return to global configuration mode.
Step 5	errdisable detect cause arp-inspection and errdisable recovery cause arp-inspection and errdisable recovery interval interval	(Optional) Enable error recovery from the dynamic ARP inspection error-disabled state, and configure the dynamic ARP inspection recover mechanism variables By default, recovery is disabled, and the recovery interval is 300 seconds. For interval interval , specify the time in seconds to recover from the error-disabled state. The range is 30 to 86400.
Step 6	exit	Return to privileged EXEC mode.
Step 7	show ip arp inspection interfaces show errdisable recovery	Verify your settings.
Step 8	copy running-config startup-config	(Optional) Save your entries in the configuration file.

To return to the default rate-limit configuration, use the **no ip arp inspection limit** interface configuration command. To disable error recovery for dynamic ARP inspection, use the **no errdisable recovery cause arp-inspection** global configuration command.

Performing Validation Checks

Dynamic ARP inspection intercepts, logs, and discards ARP packets with invalid IP-to-MAC address bindings. You can configure the switch to perform additional checks on the destination MAC address, the sender and target IP addresses, and the source MAC address.

Beginning in privileged EXEC mode, follow these steps to perform specific checks on incoming ARP packets. This procedure is optional.

	Command	Purpose
Step 1	configure terminal	Enter global configuration mode.
Step 2	ip arp inspection validate {[src-mac] [dst-mac] [ip]}	<p>Perform a specific check on incoming ARP packets. By default, no checks are performed.</p> <p>The keywords have these meanings:</p> <ul style="list-style-type: none"> • For src-mac, check the source MAC address in the Ethernet header against the sender MAC address in the ARP body. This check is performed on both ARP requests and responses. When enabled, packets with different MAC addresses are classified as invalid and are dropped. • For dst-mac, check the destination MAC address in the Ethernet header against the target MAC address in ARP body. This check is performed for ARP responses. When enabled, packets with different MAC addresses are classified as invalid and are dropped. • For ip, check the ARP body for invalid and unexpected IP addresses. Addresses include 0.0.0.0, 255.255.255.255, and all IP multicast addresses. Sender IP addresses are checked in all ARP requests and responses, and target IP addresses are checked only in ARP responses. <p>You must specify at least one of the keywords. Each command overrides the configuration of the previous command; that is, if a command enables src and dst mac validations, and a second command enables IP validation only, the src and dst mac validations are disabled as a result of the second command.</p>
Step 3	exit	Return to privileged EXEC mode.
Step 4	show ip arp inspection vlan <i>vlan-range</i>	Verify your settings.
Step 5	copy running-config startup-config	(Optional) Save your entries in the configuration file.

To disable checking, use the **no ip arp inspection validate [src-mac] [dst-mac] [ip]** global configuration command. To display statistics for forwarded, dropped, and MAC and IP validation failure packets, use the **show ip arp inspection statistics** privileged EXEC command.

Configuring the Log Buffer

When the switch drops a packet, it places an entry in the log buffer and then generates system messages on a rate-controlled basis. After the message is generated, the switch clears the entry from the log buffer. Each log entry contains flow information, such as the receiving VLAN, the port number, the source and destination IP addresses, and the source and destination MAC addresses.

A log-buffer entry can represent more than one packet. For example, if an interface receives many packets on the same VLAN with the same ARP parameters, the switch combines the packets as one entry in the log buffer and generates a single system message for the entry.

If the log buffer overflows, it means that a log event does not fit into the log buffer, and the display for the **show ip arp inspection log** privileged EXEC command is affected. A -- in the display appears in place of all data except the packet count and the time. No other statistics are provided for the entry. If you see this entry in the display, increase the number of entries in the log buffer or increase the logging rate.

The log buffer configuration applies to each stack member in a switch stack. Each stack member has the specified **logs number** entries and generates system messages at the configured rate. For example, if the interval (rate) is one entry per second, up to five system messages are generated per second in a five-member switch stack.

Beginning in privileged EXEC mode, follow these steps to configure the log buffer. This procedure is optional.

	Command	Purpose
Step 1	configure terminal	Enter global configuration mode.
Step 2	ip arp inspection log-buffer {entries number logs number interval seconds}	<p>Configure the dynamic ARP inspection logging buffer.</p> <p>By default, when dynamic ARP inspection is enabled, denied or dropped ARP packets are logged. The number of log entries is 32. The number of system messages is limited to 5 per second. The logging-rate interval is 1 second.</p> <p>The keywords have these meanings:</p> <ul style="list-style-type: none"> • For entries number, specify the number of entries to be logged in the buffer. The range is 0 to 1024. • For logs number interval seconds, specify the number of entries to generate system messages in the specified interval. <p>For logs number, the range is 0 to 1024. A 0 value means that the entry is placed in the log buffer, but a system message is not generated.</p> <p>For interval seconds, the range is 0 to 86400 seconds (1 day). A 0 value means that a system message is immediately generated (and the log buffer is always empty).</p> <p>An interval setting of 0 overrides a log setting of 0.</p> <p>The logs and interval settings interact. If the logs number X is greater than interval seconds Y, X divided by Y (X/Y) system messages are sent every second. Otherwise, one system message is sent every Y divided by X (Y/X) seconds.</p>

	Command	Purpose
Step 3	ip arp inspection vlan <i>vlan-range</i> logging { acl-match { matchlog none } dhcp-bindings { all none permit }}	Control the type of packets that are logged per VLAN. By default, all denied or all dropped packets are logged. The term <i>logged</i> means the entry is placed in the log buffer and a system message is generated. The keywords have these meanings: <ul style="list-style-type: none"> For <i>vlan-range</i>, specify a single VLAN identified by VLAN ID number, a range of VLANs separated by a hyphen, or a series of VLANs separated by a comma. The range is 1 to 4094. For acl-match matchlog, log packets based on the ACE logging configuration. If you specify the matchlog keyword in this command and the log keyword in the permit or deny ARP access-list configuration command, ARP packets permitted or denied by the ACL are logged. For acl-match none, do not log packets that match ACLs. For dhcp-bindings all, log all packets that match DHCP bindings. For dhcp-bindings none, do not log packets that match DHCP bindings. For dhcp-bindings permit, log DHCP-binding permitted packets.
Step 4	exit	Return to privileged EXEC mode.
Step 5	show ip arp inspection log	Verify your settings.
Step 6	copy running-config startup-config	(Optional) Save your entries in the configuration file.

To return to the default log buffer settings, use the **no ip arp inspection log-buffer** {**entries** | **logs**} global configuration command. To return to the default VLAN log settings, use the **no ip arp inspection vlan** *vlan-range* **logging** {**acl-match** | **dhcp-bindings**} global configuration command. To clear the log buffer, use the **clear ip arp inspection log** privileged EXEC command.

Displaying Dynamic ARP Inspection Information

To display dynamic ARP inspection information, use the privileged EXEC commands described in [Table 24-2](#):

Table 24-2 Commands for Displaying Dynamic ARP Inspection Information

Command	Description
show arp access-list [<i>acl-name</i>]	Displays detailed information about ARP ACLs.
show ip arp inspection interfaces [<i>interface-id</i>]	Displays the trust state and the rate limit of ARP packets for the specified interface or all interfaces.
show ip arp inspection vlan <i>vlan-range</i>	Displays the configuration and the operating state of dynamic ARP inspection for the specified VLAN. If no VLANs are specified or if a range is specified, displays information only for VLANs with dynamic ARP inspection enabled (active).

To clear or display dynamic ARP inspection statistics, use the privileged EXEC commands in [Table 24-3](#):

Table 24-3 *Commands for Clearing or Displaying Dynamic ARP Inspection Statistics*

Command	Description
clear ip arp inspection statistics	Clears dynamic ARP inspection statistics.
show ip arp inspection statistics [vlan <i>vlan-range</i>]	Displays statistics for forwarded, dropped, MAC validation failure, IP validation failure, ACL permitted and denied, and DHCP permitted and denied packets for the specified VLAN. If no VLANs are specified or if a range is specified, displays information only for VLANs with dynamic ARP inspection enabled (active).

For the **show ip arp inspection statistics** command, the switch increments the number of forwarded packets for each ARP request and response packet on a trusted dynamic ARP inspection port. The switch increments the number of ACL or DHCP permitted packets for each packet that is denied by source MAC, destination MAC, or IP validation checks, and the switch increments the appropriate failure count.

To clear or display dynamic ARP inspection logging information, use the privileged EXEC commands in [Table 24-4](#):

Table 24-4 *Commands for Clearing or Displaying Dynamic ARP Inspection Logging Information*

Command	Description
clear ip arp inspection log	Clears the dynamic ARP inspection log buffer.
show ip arp inspection log	Displays the configuration and contents of the dynamic ARP inspection log buffer.

For more information about these commands, see the command reference for this release.