

Cisco Aironet 1300 Series Outdoor Access Point or Bridge

Product Overview

The Cisco® Aironet® 1300 Series Outdoor Access Point or Bridge (Figure 1) is an 802.11g access point and bridge that provides high-speed and cost-effective wireless connectivity between multiple fixed or mobile networks and clients. Building a metropolitan-area wireless infrastructure with the Cisco Aironet 1300 Series provides deployment personnel with a flexible, easy-to-use solution that meets the security requirements of wide-area networking professionals. The Cisco Aironet 1300 Series can be deployed as an autonomous access point or bridge, providing intelligent network services as a standalone device. Alternatively, the Cisco Aironet 1300 Series can be deployed as part of the Cisco Unified Wireless Network, managed centrally by a Cisco wireless LAN controller.

Figure 1. Cisco Aironet 1300 Series



The Cisco Aironet 1300 Series supports the 802.11g standard—providing 54-Mbps data rates with a proven, secure technology while maintaining full backward compatibility with legacy 802.11b devices. It is delivered in a compact, rugged enclosure for deployment in outdoor environments, and is available in two versions. The Cisco Aironet 1300 Series with integrated antenna can be quickly installed to provide a LAN bridge to a remote site or multiple sites. The 1300 Series with antenna connectors supports a variety of Cisco 2.4-GHz antennas, providing range and coverage versatility.

The Cisco Aironet 1300 Series is available either as part of the Cisco Unified Wireless Network or as an autonomous access point or bridge. The Cisco Unified Wireless Network is a comprehensive solution that delivers an integrated, end-to-end wired and wireless network. Using the radio and network management features of the Cisco Unified Wireless Network for simplified deployment, the Cisco Aironet 1300 Series extends the security, scalability, reliability, ease of deployment, and manageability available in wired networks to the wireless LAN. Unified access points operate with the Lightweight Access Point Protocol (LWAPP) and work in conjunction with Cisco wireless LAN controllers and the Wireless Control System (WCS). When configured with LWAPP, the Cisco Aironet 1300 Series can automatically detect the best-available Cisco wireless LAN controller and download appropriate policies and configuration information with no hands-on intervention.

Autonomous access points are based on Cisco IOS® Software and may optionally operate with the CiscoWorks Wireless LAN Solution Engine (WLSE). Autonomous access points, along with the WLSE, deliver a core set of features and may be field-upgraded to take advantage of the full benefits of the Cisco Unified Wireless Network as requirements evolve. As an autonomous access point or bridge, the Cisco Aironet 1300 Series may be configured to operate as a wireless access point, bridge, or a workgroup bridge.

Users and Applications

The Cisco Aironet 1300 Series can provide outdoor wireless access, an ongoing savings of leased-line expenses, a method to connect networks despite physical barriers such as lakes or highways, and rapid deployment of network connections—often while waiting on other facilities, such as fiber-optic installations. The types of organizations that will benefit from the advantages of the Cisco Aironet 1300 Series include education, enterprise, government, healthcare, military, public safety, transportation, and WLAN service providers. These organizations have a variety of possible applications, as shown in Figure 2 and described in the following paragraphs.

Campus Networks

Whether the deployment is in a typical college campus or corporate offices with multiple buildings, IT professionals are faced with interconnecting local area networks around and in between each of the buildings. These LANs require cost-effective, high-bandwidth connections with seamless mobility throughout the WLAN. They also require the flexibility and control that is unavailable through leased lines or that would otherwise require trenching for new cable installations. The Cisco Aironet 1300 Series can be used as an outdoor access point, either operating with the Cisco wireless LAN controller and WCS or autonomously as an intelligent access point. It can also be used as an autonomous wireless bridge to connect remote buildings to the LAN.

Nomadic Networks and Users

More and more, networks are “on the move.” Vehicles such as buses, trains, ambulances, and patrol cars are being equipped with their own LAN-supported devices, including notebooks, personal digital assistants (PDAs), cameras, and scanners. These mobile networks provide new passenger services, improved public service, and operational efficiency but they need to be interconnected to enable information-sharing and more informed decision-making. The Cisco Aironet 1300 Series can operate in autonomous mode as a workgroup bridge connecting in-vehicle devices to Cisco Aironet access points and bridges that are fixed throughout the service area.

Outdoor Public Access

The proliferation of WLAN hotspots has allowed users to stay connected while in hotels, airports, and even coffee shops. As more users desire ubiquitous connectivity, outdoor hotspots are being added—and some include multiple city blocks or even town centers. These outdoor hotspots can be cost-effectively deployed with the Cisco Aironet 1300 Series unified or autonomous access points.

Temporary Networks

The variety of temporary solutions is limitless, with applications such as remote military campaigns, short-term office leases, temporary buildings such as trailers, or even parking lot tent sales. These deployments require a temporary network infrastructure that is rugged, portable, easy to install, and flexible. The Cisco Aironet 1300 Series can be quickly deployed, with complete functionality packaged in the integrated antenna version, or with a selection of easy-to-install remote antennas for the connectorized version.

Figure 2. Cisco Aironet 1300 Series Applications Example

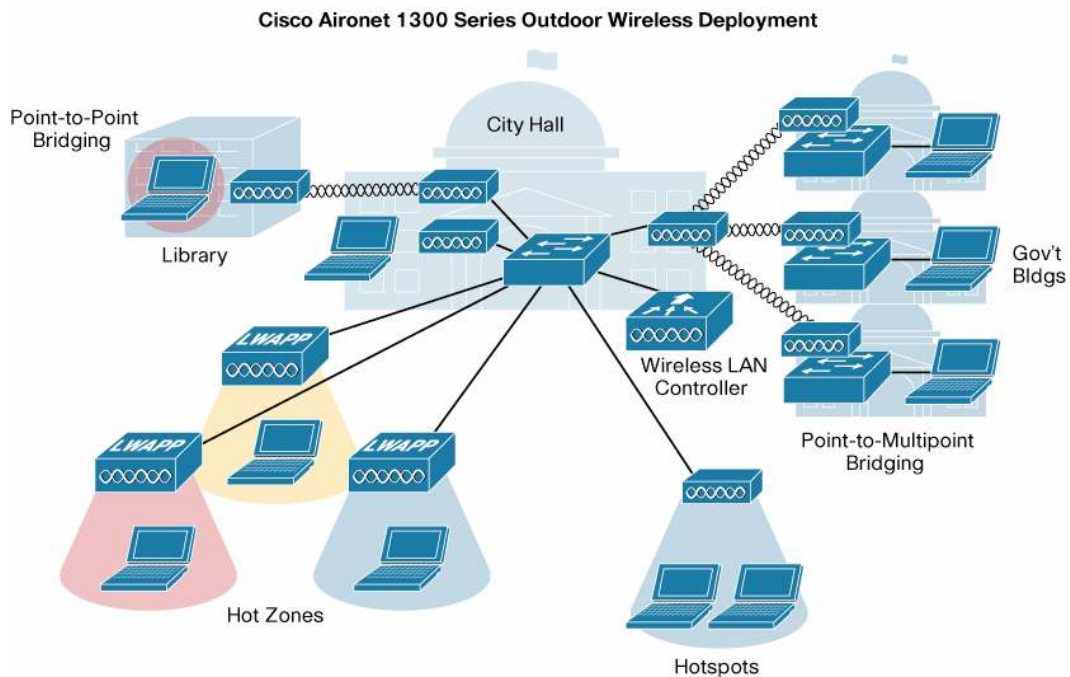

Benefits

Industry-Leading Performance

- Data rates of 54 Mbps in the 2.4-GHz band
- Bridge range of 20 miles (32 kilometers [km]) at 11 Mbps
- Aggregate throughput approaching 28 Mbps
- Maximum transmit power of 100 milliwatts (mW) for 802.11b and 30 mW for 802.11g. Maximum power setting will vary according to individual country regulations.
- For vehicle-installed deployments, over 100 km per hour speeds at 12 and 24 Mbps with 128-byte packets at 1 percent packet error rate (PER) (workgroup bridge mode connected to a Cisco Aironet access point or bridge)
- Support for antenna diversity

Low Total Cost of Ownership

- Compelling return on investment (ROI) compared to cable installation or ongoing leased-line fees
- Low bridging-system cost
- Low outdoor access-point system cost
- Ability to reuse existing Cisco Aironet Series 350 Wireless Bridges for low upgrade costs
- Investment protection with future Cisco IOS Software upgrades

Flexible and Easy to Install

- The Cisco Unified Wireless Network simplifies wireless LAN deployment and management by providing clear visibility and dynamic control of the RF environment.
- Convenient LEDs provide bridge alignment feedback and diagnostics.

- Quick-hang mounting bracket allows for an easy installation process; roof and wall mounting kits offer more mounting options.
- Rapid deployment, redeployment, and recommissioning can be achieved with no reliance upon third-party service providers or a lengthy license or trenching process.
- Multiple, configurable radio network roles enable point-to-point and point-to-multipoint bridging.
- Wide DC power-input range allows a variety of power supply options such as solar power or vehicle power (+10 to +48 volts direct current [VDC]).
- Supports a wide operating-temperature range of –22°F to 131°F (–30° to +55°C).
- Meets NEMA 4 and IP56 specifications for harsh environments.
- Supports captured antennas for easy mounting and support for external antennas, including existing Cisco Aironet 2.4-GHz antennas.

Award-Winning Security

The Cisco Aironet 1300 Series has achieved National Institute of Standards and Technology (NIST) FIPS 140-2 level 2 validation and is in process for Common Criteria validation under the National Information Assurance Partnership (NIAP) program.

The Cisco Aironet 1300 Series supports 802.11i, Wi-Fi Protected Access 2 (WPA2), WPA, and numerous Extensible Authentication Protocol (EAP) types. WPA and WPA2 are the Wi-Fi Alliance certifications for interoperable, standards-based WLAN security. These certifications support IEEE 802.1X for user-based authentication, Temporal Key Integrity Protocol (TKIP) for WPA encryption, and Advanced Encryption Standard (AES) for WPA2 encryption. These certifications help to ensure interoperability between Wi-Fi-certified WLAN devices from different manufacturers.

The Cisco Aironet 1300 Series hardware-accelerated AES encryption supports enterprise-class, government-grade secure encryption over the WLAN without compromising performance. IEEE 802.1X authentication helps to ensure that only authorized users are allowed on the network. Backward compatibility and support for WPA client devices running TKIP, the RC4 encryption algorithm, is also supported by the Cisco Aironet 1300 Series.

Cisco Aironet 1300 Series access points operating with LWAPP support Cisco Unified Intrusion Detection System or Intrusion Prevention System (IDS/IPS), which is part of the Cisco Self-Defending Network and is the industry's first integrated wired and wireless network security solution. The Cisco Unified IDS/IPS takes a comprehensive approach to security—at the wireless edge, wired edge, WAN edge, and through the data center. When a trusted client acts maliciously, the Cisco wired IDS detects the attack and sends shun requests to the Cisco wireless LAN controllers, which will then disassociate the client device. Cisco Unified IDS goes beyond simple fire walling. If a user is allowed to access a specific server, but is not allowed to access a particular directory on the server, the anomalous behavior is detected and mitigated.

Autonomous or unified Cisco Aironet 1300 Series Access Points support management frame protection for the authentication of 802.11 management frames by the wireless network infrastructure. This allows the network to detect spoofed frames from access points or malicious users impersonating infrastructure access points. If an access point detects a malicious attack, an incident will be generated by the access point and reports will be gathered on the controller, Cisco WCS, or CiscoWorks WLSE.

Product Architecture

A flexible outdoor wireless-bridge or access-point solution is provided through the combination of the Cisco Aironet 1300 Series, a power injector, and options for both antennas and mounting. Figure 3 shows how the units connect.

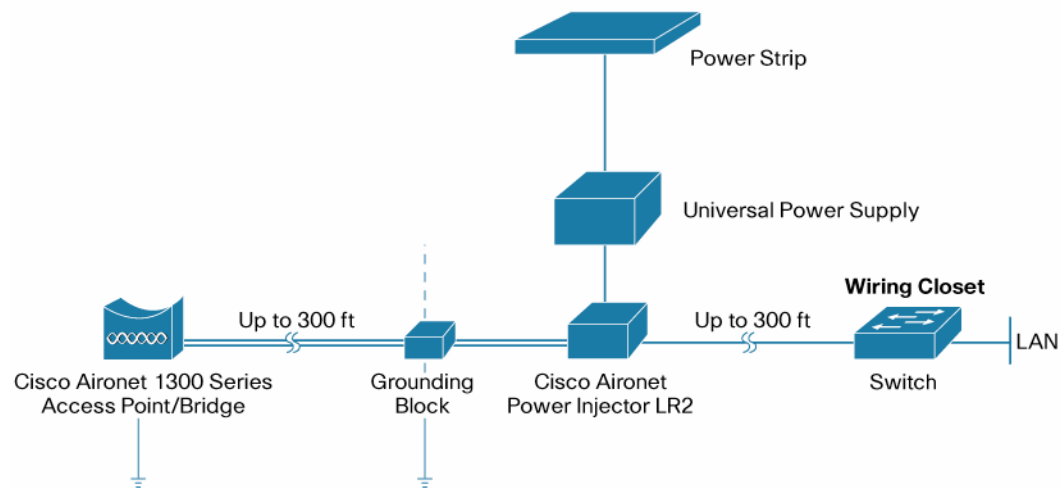
Figure 3. Network Diagram with Power Injector

Cisco Aironet 1300 Series

The Cisco Aironet 1300 Series provides the 802.11g interface for access-point capability or bridge connections. By placing the unit outdoors, close to the antenna, you can minimize the wireless cable losses—thereby maximizing the range of the network. The unit is available with either an integrated antenna, or with connectors for external antennas (Figure 4). The high-gain, integrated antenna is designed for easy installations of point-to-point links or non-root nodes of point-to-multipoint networks as an autonomous bridge. The nonintegrated antenna version provides professional installers with an RP-TNC connector that allows the deployment of omnidirectional, sector, or high-gain dish antennas for specific application requirements.

Figure 4. Cisco Aironet 1300 Series Connector Options

Power Injector

The Cisco Aironet Bridge Power Injector converts the standard 10/100BASE-T Ethernet interface that is suitable for weather-protected areas to a dual F-Type connector interface for coaxial cables that are more suitable for harsh outdoor environments. The power injector also provides power to the outdoor unit over the same cables with a power-discover feature and surge protection. To support longer cabling from your wired switch or router, the power injector enables total cable runs up to 200 meters (Category 5 [Cat5] and coaxial). The Cisco Aironet 1300 Series ships with the Cisco Aironet Power Injector LR2 (Figure 5) and an AC power supply.

Figure 5. Cisco Aironet Power Injector AIR-PWRINJ-BLR2/AIRPWRINJ-BLR2T



The optional Cisco Aironet Power Injector LR2T takes power from any +12 to +40 VDC source not supplied by Cisco. Typically, the DC source is a vehicle or solar-power source (Figure 6). This power injector provides the flexibility needed when an AC power source is not available.

Figure 6. Network Diagram with Optional Power Injector

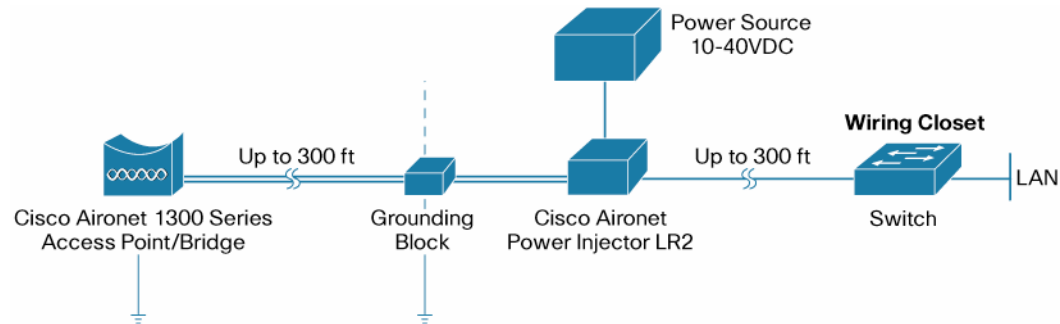

Mounting Hardware and Antennas

In addition to having a variety of antennas available from Cisco, the Cisco 1300 Series also has different mounting options (Figure 7). These optional mounting kits are available for mounting to a roof, wall, or pole. The quick-hang mounting bracket enables a simple, one-person installation. For more information on available antennas, please refer to the Cisco Aironet Antennas and Accessories Data Sheet and Reference Guide:

- Data Sheet:
http://www.cisco.com/en/US/prod/collateral/wireless/ps7183/ps469/product_data_sheet09186a008022b11b.html
- Reference Guide:
http://www.cisco.com/en/US/prod/collateral/wireless/ps7183/ps469/product_data_sheet09186a008008883b.html

Figure 7. Cisco Aironet 1300 Series Mounting Hardware and Antennas



Features

The Cisco Aironet 1300 Series access point or bridge provides the following features.

Antenna Alignment Assistance

The autonomous Cisco Aironet 1300 Series provides an autoconfiguration and installation mode for quick deployment of point-to-point links without the need for configuration through Telnet, FTP, or Simple Network Management Protocol (SNMP). This mode provides LEDs with signal-strength information used in the installation and alignment process. As a result, installers are free to perform their installation process and verify the link quality without knowledge of Cisco IOS Software or data networking.

Automatic RF Configuration

Under the Cisco Unified Wireless Network, radio resource management provides automatic configuration of RF parameters for access points such as the Cisco Aironet 1300 Series Access Points. The result is a coordinated RF plan for access points under the span of the Cisco wireless LAN controller, which also recognizes the presence of other RF emitting devices. This minimizes interference to and from neighboring access points, ensuring optimal network capacity.

Seamless Layer 2 and Layer 3 Roaming

The Cisco Aironet 1300 Series provides fast secure roaming of wireless clients and autonomous non-root bridges and workgroup bridges. In both the unified access point and the autonomous access point, the encryption keys for mobile devices are cached locally, allowing the mobile device to roam between access points while remaining authenticated to the network. This significantly reduces roaming time by eliminating the need to conduct the four-way handshake with each roam. Autonomous non-root bridges and workgroup bridges also scan in the background to search for alternative Cisco Aironet access points and bridges that mobile device may be roaming to, which also reduces roaming time.

Support for Port Aggregation Protocol and Cisco Fast EtherChannel Technology

Bandwidth can be increased between bridged networks through the aggregation of multiple autonomous bridges at each site via Cisco Fast EtherChannel[®] technology, Port Aggregation Protocol (PAgP), or routing protocols.

Wireless Link-Distance Adjustment

For an autonomous Cisco Aironet 1300 Series device, the link-distance parameter allows the user to tune the Carrier-Sense Multiple Access/Collision Avoidance (CSMA/CA) parameters for the particular range in use to maximize performance.

Wireless Packet Concatenation

The concatenation of smaller packets into larger ones allows autonomous Cisco Aironet 1300 Series access point or bridge to more efficiently use the wireless medium and provide higher overall data throughputs.

Wireless Programmable Clear-Channel Assessment

With a programmable clear-channel assessment, an autonomous Cisco Aironet 1300 Series access point or bridge can be configured to the particular background-interference level found in your environment. This provides reduced contention overhead with other wireless systems.

Summary

The Cisco Aironet 1300 Series is a flexible outdoor 802.11b and 802.11g access point or bridge that provides high-speed and cost-effective wireless connectivity between multiple fixed or mobile networks and clients.

Product Specifications

Link Roles and Product Compatibility

Table 1 outlines the link roles in which the Cisco Aironet 1300 Series can operate, and identifies the products that it is compatible with in the particular role.

Table 1. Link Role and Product Compatibility

Role	Applications	Unified or Autonomous Architecture	Compatibility
Access Point	Engineered specifically for harsh outdoor environments, yet also capable in indoor deployments, the Cisco Aironet 1300 Series is ideal for WLANs requiring outdoor coverage. The Cisco Aironet 1300 Series is Wi-Fi certified as an access point and also supports the innovative features available with Cisco Aironet and Cisco Compatible client devices.	Unified or Autonomous	<ul style="list-style-type: none"> Compatible with any Wi-Fi certified WPA or WPA2 client device for basic capability Compatible with Cisco Aironet clients and Cisco Compatible clients for extended capability
Bridge	The Cisco Aironet 1300 Series supports either point-to-point or point-to-multipoint configurations to cost-effectively interconnect remote, temporary, or mobile networks. It can serve as an upgrade or replacement to the Cisco Aironet 350 Wireless Bridge by providing over-the-air compatibility with existing Cisco Aironet 350 Series Wireless Bridges. While in bridge mode, client associations are also accepted—effectively providing simultaneous bridge and access-point capability.	Autonomous	Compatible with Cisco Aironet 1300 Series and 350 Series Wireless Bridges
Workgroup Bridge	There is no hard/soft limit on the number of devices you can have, however we only recommend up to a maximum of 20 devices.	Autonomous	Supports operation with Cisco Aironet access points and Cisco bridges

Protocols

Table 2 lists the protocols supported by the Cisco Aironet 1300 Series.

Table 2. Protocols

Protocols	Description
Air Interface Standard	IEEE 802.11b or IEEE 802.11g Note: Autonomous bridge mode has enhancements to the standard to allow longer-range bridging communications.
Frequency Band	<ul style="list-style-type: none"> 2.412 to 2.462 GHz (FCC) 2.412 to 2.472 GHz (ETSI) 2.412 to 2.472 GHz (TELEC)
Wireless Modulation	<p>802.11b</p> <ul style="list-style-type: none"> Direct Sequence Spread Spectrum (DSSS): <ul style="list-style-type: none"> Differential Binary Phase Shift Keying (DBPSK) at 1 Mbps Differential Quadrature Phase Shift Keying (DQPSK) at 2 Mbps Complementary Code Keying (CCK) at 5.5 and 11 Mbps <p>802.11g</p> <ul style="list-style-type: none"> Orthogonal Frequency Divisional Multiplexing (OFDM): <ul style="list-style-type: none"> BPSK at 6 and 9 Mbps QPSK at 12 and 18 Mbps 16-quadrature amplitude modulation (QAM) at 24 and 36 Mbps 64-QAM at 48 and 54 Mbps
Media Access Protocol	Carrier-Sense Multiple Access with Collision Avoidance (CSMA/CA)
Lightweight Access Point Protocol	A network protocol for lightweight access points that also provides for centralized management.
Operating Channels	802.11b/g <ul style="list-style-type: none"> ETSI: 13 Americas: 11 TELEC (Japan): 13

Protocols	Description
Nonoverlapping Channels	3
Security—Bridge Role*	<p>Cisco Wireless Security Suite, including:</p> <p>Authentication</p> <p>802.1X support including LEAP to yield mutual authentication and dynamic per-user, per session encryption keys</p> <p>Encryption</p> <ul style="list-style-type: none"> • Cisco TKIP or WPA TKIP; key hashing (per-packet keying), Message Integrity Check (MIC) and broadcast key rotation • AES (802.11i)
Security—Access Point Role	<p>Cisco Wireless Security Suite supporting WPA and WPA2, including:</p> <p>Authentication</p> <ul style="list-style-type: none"> • Management frame protection provides for the authentication of 802.11 management frames by the wireless network infrastructure. This allows the network to detect spoofed frames from access points or malicious users impersonating infrastructure access points. If an access point detects a malicious attack, an incident will be generated by the access points and reports will be gathered on the Cisco wireless LAN controller, Cisco WCS, or CiscoWorks WLSE. • 802.1X support including Cisco LEAP, Protected EAP-Generic Token Card (PEAP-GTC), PEAP-Microsoft Challenge Authentication Protocol Version 2 (MSCHAPv2), EAP Message Digest 5 (EAP MD5), EAP-Transport Layer Security (EAP-TLS), EAP-Tunneled TLS (EAP-TTLS), EAP-Subscriber Identity Module (EAP-SIM), and EAP-Flexible Authentication via Secure Tunneling (EAP-FAST) to yield mutual authentication and dynamic per user, per-session encryption keys <p>Encryption</p> <ul style="list-style-type: none"> • WPA: Cisco TKIP or WPA TKIP; key hashing (per-packet keying), MIC and broadcast key rotation • WPA2: AES (802.11i)
Security—Workgroup Bridge Role*	<p>Cisco Wireless Security Suite, including:</p> <p>Authentication</p> <ul style="list-style-type: none"> • 802.1X support including Cisco LEAP to yield mutual authentication and dynamic per-user, per session encryption keys <p>Encryption</p> <ul style="list-style-type: none"> • Cisco TKIP or WPA TKIP; key hashing (per-packet keying), MIC and broadcast key rotation • AES (802.11i)
SNMP Compliance	Versions 1 and 2

* Cisco Aironet 1300 Series can operate as a workgroup bridge or wireless bridge when it is an autonomous device. When the Cisco Aironet 1300 Series is operating under the Cisco Unified Wireless Network architecture, it only operates as an access point.

Components

Table 3 lists the components available for the Cisco Aironet 1300 Series.

Table 3. Components

Components	Description
Power Injector LR2	The power injector converts the standard 10/100BASE-T Ethernet Cat5 RJ-45 interface that is suitable for weather-protected areas to a dual F-Type connector interface for dual coaxial cables that are more suitable for harsh outdoor environments. While providing a 100BASE-T interface to the Cisco Aironet 1300 Series, the power injector also provides power to the unit over the same cables with a power discovery feature that protects other appliances from damage should they accidentally be connected. As an added benefit to the installer, the automatic medium-dependent interface crossover (Auto-MDIX) feature is built in, allowing the dual cables to be swapped while maintaining the same capability. To support longer cable runs from your network switch or router, the power injector is designed to accommodate up to a 100 meter coaxial cable run plus 100 meters of indoor Cat5 cable—enabling total cable runs up to 200 meters. Lightning and surge protection is also included at the F-Type connector interface to provide added protection to your network devices. The power injector requires a 48V DC source supplied by Cisco.
Power Injector LR2T	The Power Injector LR2T supports all the capabilities of LR2. It is designed for use in transportation applications and operates with an input voltage range of +12 to +40V DC. The DC source is provided by the user. The LR2T can therefore be vehicle- or solar-powered.
Power Supply	<ul style="list-style-type: none"> • 48V DC supply for AIR-PWRINJ-BLR2= • User-supplied 12 to 40V DC source for AIR-PWRINJ_BLR2T=. Could require an external load-dump-module for automotive and bus installations.
AIR-BR1310G- x-K9 or AIR LAP1310G-x-K9 Integrated Antenna	<ul style="list-style-type: none"> • Vertical polarization • 13-dBi gain • 36°E-plane by 38°H-plane (3-dB beam width)

Interfaces

Table 4 lists the Cisco Aironet 1300 Series interfaces.

Table 4. Interfaces

	AIR-BR1310G-x-K9 AIR-BR1310G-x-K9-R AIR-LAP1310G-x-K9 AIR-LAP1310G-x-K9R	AIR-PWRINJ-BLR2 AIR-PWRINJ-BLR2T
Status LEDs	Four LEDs: Install, Radio, Status, and Ethernet	One bicolor LED showing power status
F-Type Connectors	Dual coaxial cable carries full-duplex Ethernet, DC power, and full-duplex console port (RS-232 connection)	Dual coaxial cable carries full-duplex Ethernet, DC power, and full-duplex console port (RS 232 connection)
Antenna Interface	<ul style="list-style-type: none"> AIR-BR1310G-x-K9 or AIR-LAP1310G-x-K9: Air interface (integrated directional antenna) AIR-BR1310G-x-K9-R or AIR-LAP1310G-x-K9R: Two RP-TNC type connectors for external antennas 	—
DC Power	—	One two-pin Switchcraft connector (with threaded locking sleeve) and matching connector
RJ-45 Interface	—	One RJ-45 connector for console-port access (9600 bps only), a second RJ-45 connector for 10/100BASE-T LAN interface
Grounding Lugs	Two grounding lugs for lightening protection.	—

Memory Requirements

Table 5 lists the memory specifications for the Cisco Aironet 1300 Series.

Table 5. Memory Requirements

8 MB of Flash Memory	Memory space for future firmware upgrades to support new 802.11 standards and advanced features.
-----------------------------	--

Performance

Table 6 lists the Cisco Aironet 1300 Series performance capabilities.

Table 6. Performance Capabilities

	AIR-BR1310G-A-K9 or AIR-LAP1310G-A-K9	AIR-BR1310G-A-K9-R or AIR-LAP1310G-A-K9R
Available Transmit Power Settings	802.11b: <ul style="list-style-type: none"> 100 mW (20 dBm) 50 mW (17 dBm) 30 mW (15 dBm) 20 mW (13 dBm) 10 mW (10 dBm) 5 mW (7 dBm) 1 mW (0 dBm) 802.11g: <ul style="list-style-type: none"> 30 mW (15 dBm) 20 mW (13 dBm) 10 mW (10 dBm) 5 mW (7 dBm) 1 mW (0 dBm) 	802.11b: <ul style="list-style-type: none"> 100 mW (20 dBm) 50 mW (17 dBm) 30 mW (15 dBm) 20 mW (13 dBm) 10 mW (10 dBm) 5 mW (7 dBm) 1 mW (0 dBm) 802.11g: <ul style="list-style-type: none"> 30 mW (15 dBm) 20 mW (13 dBm) 10 mW (10 dBm) 5 mW (7 dBm) 1 mW (0 dBm)
	Note: Maximum power setting will vary according to individual country regulations.	
Maximum Operational Receive Level	-20 dBm	-20 dBm
Maximum Survivable Receive Level	10 dBm	10 dBm

	AIR-BR1310G-A-K9 or AIR-LAP1310G-A-K9	AIR-BR1310G-A-K9-R or AIR-LAP1310G-A-K9R
Receive Sensitivity (10 Percent with 3200 Byte Packets)	<ul style="list-style-type: none"> • 1 Mbps: -94 dBm • 2 Mbps: -91 dBm • 5.5 Mbps: -89 dBm • 11 Mbps: -85 dBm • 6 Mbps: -90 dBm • 9 Mbps: -89 dBm • 12 Mbps: -86 dBm • 18 Mbps: -84 dBm • 24 Mbps: -81 dBm • 36 Mbps: -77 dBm • 48 Mbps: -73 dBm • 54 Mbps: -72 dBm 	<ul style="list-style-type: none"> • 1 Mbps: -94 dBm • 2 Mbps: -91 dBm • 5.5 Mbps: -89 dBm • 11 Mbps: -85 dBm • 6 Mbps: -90 dBm • 9 Mbps: -89 dBm • 12 Mbps: -86 dBm • 18 Mbps: -84 dBm • 24 Mbps: -81 dBm • 36 Mbps: -77 dBm • 48 Mbps: -73 dBm • 54 Mbps: -72 dBm
Maximum Bridge Relative Velocity (Autonomous-Mode Only)	Over 100 km per hour at 12 and 24 Mbps with 128-byte packets at 1 percent PER	
Access Point Role: Outdoor Range	<p>Americas</p> <ul style="list-style-type: none"> • 865 feet (260 meters) at 54 Mbps • 3465 feet (1055 meters) at 11 Mbps <p>ETSI</p> <ul style="list-style-type: none"> • 150 feet (45 meters) at 54 Mbps • 775 feet (235 meters) at 11 Mbps <p>TELEC</p> <ul style="list-style-type: none"> • 485 feet (145 meters) at 54 Mbps • 1095 feet (330 meters) at 11 Mbps <p>Note: Access point with 13-dBi integrated antenna and Cisco clients</p>	<p>Americas</p> <ul style="list-style-type: none"> • 350 feet (105 meters) at 54 Mbps • 1410 feet (430 meters) at 11 Mbps <p>ETSI</p> <ul style="list-style-type: none"> • 195 feet (60 meters) at 54 Mbps • 630 feet (190 meters) at 11 Mbps <p>TELEC</p> <ul style="list-style-type: none"> • 195 feet (60 meters) at 54 Mbps • 445 feet (135 meters) at 11 Mbps <p>Note: Access point with 5.2-dBi patch antenna and Cisco clients</p>
Bridge Role: Point to Point Range*	<p>Americas</p> <ul style="list-style-type: none"> • 1.3 miles (2 km) at 54 Mbps • 9 miles (15 km) at 11 Mbps <p>EMEA</p> <ul style="list-style-type: none"> • 0.2 miles (0.36 km) at 54 Mbps • 2.3 miles (3.5 km) at 11 Mbps <p>TELEC</p> <ul style="list-style-type: none"> • 0.7 miles (1.1 km) at 54 Mbps • 3.2 miles (5 km) at 11 Mbps <p>Note: 13-dBi integrated antenna at root and non root bridge</p>	<p>Americas</p> <ul style="list-style-type: none"> • 4.5 miles (7 km) at 54 Mbps • 14 miles (23 km) at 11 Mbps <p>EMEA</p> <ul style="list-style-type: none"> • 5.5 miles (9 km) at 11 Mbps <p>TELEC</p> <ul style="list-style-type: none"> • 4.5 miles (7 km) at 54 Mbps • 12 miles (20 km) at 11 Mbps <p>Note: 21-dBi dish antenna at root and non root bridge</p>
Bridge Role: Point to Multipoint Range*	<p>Americas</p> <ul style="list-style-type: none"> • 1.1 miles (1.8 km) at 54 Mbps • 8 miles (13 km) at 11 Mbps <p>EMEA</p> <ul style="list-style-type: none"> • 0.25 miles (0.4 km) at 54 Mbps • 1.1 miles (1.8 km) at 11 Mbps <p>TELEC</p> <ul style="list-style-type: none"> • 0.8 miles (1.3 km) at 54 Mbps • 3.6 miles (5.8 km) at 11 Mbps <p>Note: 14-dBi sector antenna at root and 13-dBi integrated antenna at non-root</p>	<p>Americas</p> <ul style="list-style-type: none"> • 2.0 miles (3.3 km) at 54 Mbps • 10 miles (16 km) at 11 Mbps <p>EMEA</p> <ul style="list-style-type: none"> • 2.5 miles (4 km) at 11 Mbps <p>TELEC</p> <ul style="list-style-type: none"> • 2.0 miles (3.3 km) at 54 Mbps • 9.0 miles (14 km) at 11 Mbps <p>Note: 14-dBi sector at root and 21-dBi dish at non root</p>

* Bridge role is only available for autonomous deployments. The distances referenced here are approximations and should be used for estimation purposes only.

Physical Specifications

Table 7 lists the physical specifications of the Cisco Aironet 1300 Series.

Table 7. Physical Specifications

	AIR-BR1310G-x-K9 AIR BR1310G x K9 R AIR-LAP1310G-x-K9 AIR-LAP1310G-x-K9R	AIR-PWRINJ-BLR2	AIR-PWRINJ-BLR2T
Dimensions	8 in. x 8.1 in. x 3.12 in. (20.3 cm x 20.57 cm x 7.87 cm)	4.62 in. x 4.76 in. x 1.07 in. (11.73 cm x 12.09 cm x 2.71 cm)	4.62 in. x 4.76 in. x 1.07 in. (11.73 cm x 12.09 cm x 2.71 cm)
Weight	2.5 lb (1.25 kg)	2 lb (1 kg)	2 lb (1 kg)
Operational Temperature	-22° to +131°F (-30° to +55°C)	-22° to +131°F (-30° to +55°C)	-22° to +131°F (-30° to +55°C)
Storage Temperature	-40° to +185°F (-40° to +85°C)	-40° to +185°F (-40° to +85°C)	-40° to +185°F (-40° to +85°C)
Operational Altitude	10,000 ft (3048m)	10,000 ft (3048m)	10,000 ft (3048m)
Storage Altitude	16,000 ft (4877 m)	16,000 ft (4877 m)	16,000 ft (4877 m)
Humidity	0 to 100% at 100°F (38°C) (condensing)	0 to 90% at 100°F (38°C) (noncondensing)	0 to 90% at 100°F (38°C) (noncondensing)
Vibration	SAEJ1455 section 4.9	SAEJ1455 section 4.9	SAEJ1455 section 4.9
Enclosure	NEMA 4; IP56; UL2083; environmentally sealed	UL2083; metal case	UL2083; metal case

Power Requirements

Table 8 lists Cisco Aironet 1300 Series power requirements.

Table 8. Power Requirements

	AIR-BR1310G-x-K9 AIR BR1310G x-K9-R AIR-LAP1310G-x-K9 AIR-LAP1310G-x-K9R	AIR-PWRINJ-BLR2	AIR-PWRINJ-BLR2T
AC Power	Not required—uses DC voltage from power injector	100 to 240V AC, ±10% (power supply provided by Cisco)	Not required
DC Power	—	<ul style="list-style-type: none"> +48V DC, ±10% Up to 9 W 	<ul style="list-style-type: none"> +12 to +40V DC, ±10% Up to 11 W

Approvals and Compliance

The Cisco Aironet 1300 Series meets the following approvals and compliance standards (Table 9).

Table 9. Approvals and Compliance

	AIR-BR1310G-x-K9 AIR-BR1310G-x-K9-R AIR-LAP1310G-x-K9 AIR-LAP1310G-x-K9R	AIR-PWRINJ-BLR2 AIR-PWRINJ-BLR2T
Country Compliance	Customers are responsible for verifying approval for use in their country. Please visit http://www.cisco.com/go/aironet/compliance to verify approval and to identify the regulatory domain that corresponds to a particular country. Not all regulatory domains have been approved. As they are approved, the part numbers will be available on the Global Price List.	
Wi-Fi Certification		—

	AIR-BR1310G-x-K9 AIR-BR1310G-x-K9-R AIR-LAP1310G-x-K9 AIR-LAP1310G-x-K9R	AIR-PWRINJ-BLR2 AIR-PWRINJ-BLR2T
Safety	<ul style="list-style-type: none"> • UL 60950 third edition • CSA C22.2 No. 60950-00 • IEC 60950 Sec Ed, amendments 1-4 • EN 60950; 1992, amendments 1-4 • CSA 94/UL50—NEMA rated 	<ul style="list-style-type: none"> • UL 60950 third edition • CSA C22.2 No. 60950-00 • IEC 60950 Sec Ed, amendments 1-4 • EN 60950; 1992, amendments 1-4 • UL2043 • FIPS 140-2 prevalidation list
Radio Approvals	<ul style="list-style-type: none"> • FCC Part 15.247 • RSS—139-1, RSS-210 (Canada) • EN 300.328 (Europe) • Telec 33B (Japan) • ARIB-STD-T66 v2.1 • FCC Bulletin OET-65CRSS-102 • Designed to EN60945 	—
EMI and Susceptibility (Class B)	<ul style="list-style-type: none"> • FCC Part 15.107 and 15.109 Class B • ICES-003 Class B (Canada) • EN 55022 Class B • EN 55024 • AS/NZS 3548 Class B • VCCI Class B • EN 301.489-1 and 17 (Europe) • Designed to CISPR 25, ISO 11452-24, EN50121, EN60571 and SAEJ1113 	<ul style="list-style-type: none"> • FCC Part 15.107 and 15.109 • Class B • ICES-003 Class B (Canada) • EN 55022 Class B • EN 55024 • AS/NZS 3548 Class B • VCCI Class B • EN 301.489-1 and 17 (Europe)

Additional Specifications

Warranty: One year

Ordering Information

To place an order, visit the [Cisco Ordering Home Page](#). For assistance in determining the correct wireless bridge to order, as well as appropriate accessories, please read the [Cisco Aironet 1300 Series Ordering Guide](#).

To Download the Software

Cisco Aironet software can be downloaded at the [Cisco Software Center](#).

Service and Support

Cisco Systems offers a wide range of service programs to accelerate customer success. These innovative programs are delivered through a unique combination of people, processes, tools, and partners, resulting in high levels of customer satisfaction. Cisco services help you to protect your network investment, optimize network operations, and prepare the network for new applications to extend network intelligence and the power of your business. For more information about Cisco Services, see [Cisco Technical Support Services](#).

For More Information

For more information about the Cisco Aironet 1300 Series, visit <http://www.cisco.com/go/aironet> or contact your local account representative.



Americas Headquarters
Cisco Systems, Inc.
San Jose, CA

Asia Pacific Headquarters
Cisco Systems (USA) Pte. Ltd.
Singapore

Europe Headquarters
Cisco Systems International BV
Amsterdam, The Netherlands

Cisco has more than 200 offices worldwide. Addresses, phone numbers, and fax numbers are listed on the Cisco Website at www.cisco.com/go/offices.

CCDE, CCENT, CCSI, Cisco Eos, Cisco HealthPresence, Cisco IronPort, the Cisco logo, Cisco Lumin, Cisco Nexus, Cisco Nurse Connect, Cisco StackPower, Cisco StadiumVision, Cisco TelePresence, Cisco Unified Computing System, Cisco WebEx, DCE, Flip Channels, Flip for Good, Flip Mino, Flip Video, Flip Video (Design), Flipshare (Design), Flip Ultra, and Welcome to the Human Network are trademarks; Changing the Way We Work, Live, Play, and Learn, Cisco Store, and Flip Gift Card are service marks; and Access Registrar, Aironet, AsyncOS, Bringing the Meeting To You, Catalyst, CCDA, CCDP, CCIE, CCIIP, CCNA, CCNP, CCSP, CCVP, Cisco, the Cisco Certified Internetwork Expert logo, Cisco IOS, Cisco Press, Cisco Systems, Cisco Systems Capital, the Cisco Systems logo, Cisco Unity, Collaboration Without Limitation, EtherFast, EtherSwitch, Event Center, Fast Step, Follow Me Browsing, FormShare, GigaDrive, HomeLink, Internet Quotient, IOS, iPhone, iQuick Study, IronPort, the IronPort logo, LightStream, Linksys, MediaTone, MeetingPlace, MeetingPlace Chime Sound, MGX, Networkers, Networking Academy, Network Registrar, PCNow, PIX, PowerPanels, ProConnect, ScriptShare, SenderBase, SMARTnet, Spectrum Expert, StackWise, The Fastest Way to Increase Your Internet Quotient, TransPath, WebEx, and the WebEx logo are registered trademarks of Cisco Systems, Inc. and/or its affiliates in the United States and certain other countries.

All other trademarks mentioned in this document or website are the property of their respective owners. The use of the word partner does not imply a partnership relationship between Cisco and any other company. (0907R)