

Power over Ethernet: Cisco Inline Power and IEEE 802.3af

Introduction

With the advent of Cisco® IP Telephony, Cisco Systems® innovated mechanisms whereby Cisco Catalyst® multiservice switches could deliver Power over Ethernet (PoE) using existing copper cabling to IP phones. The need to deliver 48 Volt (V) power to IP phones over 10/100BASE-T Ethernet was driven by the requirement to support the basic features of traditional telephones. One of the critical requirements was the elimination of local power cords connected to the IP phone. Since the launch of Cisco Inline Power in March 2000, Cisco has shipped more than 16 million inline

power capable ports on the Cisco Catalyst 3500, 4500 and 6500 series of Ethernet switches.

Due to the rapid acceptance of IP telephony solutions, the IEEE 802.3af Power over Ethernet committee, of which Cisco is a leading contributor, led efforts to standardize Power over Ethernet. The IEEE 802.3af-2003 *Carrier Sense Multiple Access with Collision Detection (CSMA/CD) Access method and Physical Layer Specification. Amendment: Data Terminal Equipment (DTE) Power via media Dependent Interface* standard that was approved June 12, 2003 defines how power may be delivered to 10BASE-T, 100BASE-T or 1000BASE-T attached devices.

With the announcement of IEEE 802.3af-2003 compliant 10/100/1000BASE-T support for Cisco Catalyst multiservice switches, Cisco delivers standards based Power over Ethernet that is backward compatible with the installed base of Cisco prestandard Power over Ethernet capable switches. This announcement underlines the commitment by Cisco Systems to deliver standards based solutions and investment protection to enterprises that have deployed Cisco Power over Ethernet solutions.

Although Power over Ethernet was originally intended to support power to Cisco IP phones, development of other Power over Ethernet capable devices has





driven the expansion and value of this technology including extending Power over Ethernet support to Cisco 802.11 wireless access points. These developments have required that greater power delivery be considered as Power over Ethernet is extended to support more complex applications.

Figure 1
Power Requirements for Power over Ethernet Devices

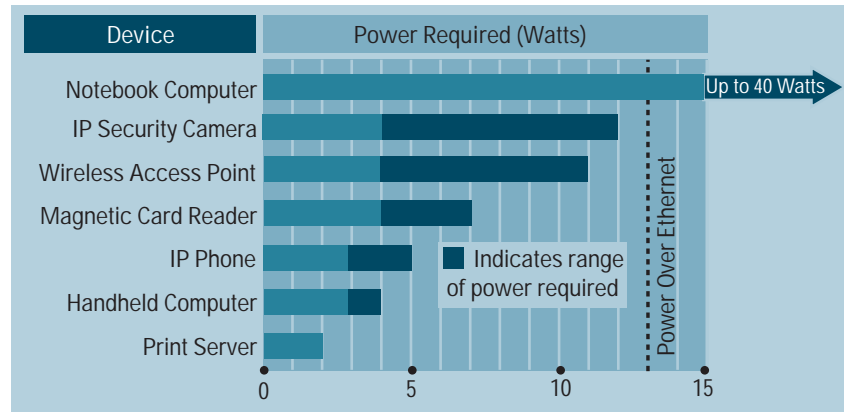

Many vendors have been quick to recognize the applications to which Power over Ethernet may be applied. Although originally developed to deliver power to IP phones, Power over Ethernet is also seeing relevance in other applications such as Video surveillance camera's, digital signage, electronic badge readers and even electric guitars!¹ As an example, magnetic card readers and magnetic door locks may be powered using Power over Ethernet that would allow personnel to be tracked for safety or security purposes by linking IP surveillance with the last known location of a user.

The IEEE 802.3af standard supports delivery of Power over Ethernet up to 15.4W per port that may be used to deliver power to a variety of devices (figure 1.) The IEEE 802.3af standard also defines the concept of power classes including a reserved class that may be extended to support increased power delivery to PDs in the future. As an example, this class may be expanded to support the power requirements of a laptop PC that typically draws much more than the 15.4W currently allowed for within IEEE 802.3af.

The support of 10/100/1000 Power over Ethernet across the Cisco Catalyst modular switch portfolio and support for 10/100 across all Cisco Catalyst switch products is critically important as enterprises look to new applications to maximize operational efficiencies. The support of IEEE 802.3af over 10/100/1000BASE-T interfaces allows Enterprises the flexibility to deploy future proof infrastructure that is ready for next generation PCs that can exploit the advantages of 1Gbps Ethernet, thereby increasing the efficiency of existing applications, as well as providing a platform for exploiting next generation applications enabled using Power over Ethernet. In addition, the combination of Power over Ethernet with Gigabit Ethernet connections to the desktop ensure investment protection for networking systems designed to depreciate and remain active for up to seven years.

1. Gibson Magic <http://www.eetimes.com/sys/news/OEG20030124S0035>.



This document discusses Cisco Inline Power (ILP) and the IEEE 802.3af standard with respect to delivery of delivery of Power over Ethernet, the differences and the considerations in terms of power management.

IEEE 802.3af Power over Ethernet

The IEEE 802.3af-2003 Power over Ethernet standard defines terminology to describe a port that acts as a power source (PSE) to a powered device (PD), defines how a powered device is detected and also defines two (2) methods of delivering Power over Ethernet to the discovered powered device. IEEE 802.3af power may be delivered using a Power over Ethernet capable Ethernet port, which is referred to as an End-Point PSE or by a mid-span PSE that can be used to deliver Power over Ethernet in the event an existing non-Power over Ethernet capable Ethernet switch is used.

The IEEE 802.3af standard states that power may be delivered by an end-point PSE, using either the active data wires of an Ethernet port or the spare wires, to a powered device. An end-point PSE, such as a Power over Ethernet capable Ethernet switch, may implement either scheme. If a mid-span PSE is used, then the mid-span PSE can only implement power delivery over the spare pairs of the copper cabling and cannot be used to deliver Power over Ethernet over 1000BASE-T connections. It should be noted that even if a device supports both methods of providing power, only one mechanism may be used to deliver power to a powered device.

Figure 2
End-Point PSE Power over Ethernet Delivery



The first mechanism, which is supported within Cisco Catalyst Ethernet switches, is to use the data pairs (pins 1,2 & 3,6) to transmit power, which is sometimes referred to as “phantom” power. The second power delivery mechanism is to use the unused, from a 10/100BASE-T perspective, pairs (pins 4,5 &7,8) to deliver power that is supported within mid-span power delivery.

Cisco Inline Power and IEEE 802.3af

Cisco launched Cisco Inline Power in March 2000 and has shipped more than 16 million inline power capable ports on the Catalyst 3500, 4500 and 6500 families of Ethernet switches. This innovation was quickly recognized within the industry and the IEEE started work to standardize Power over Ethernet implementations such that multi-vendor interoperability was enabled. Since the inception of Cisco prestandard Power over Ethernet capable IP phones, several powered devices have now been developed including Color IP phones, Video camera’s etc. that utilize Power



over Ethernet. With the ratification of IEEE802.3af, as with other Cisco innovations, Cisco will support both IEEE 802.3af and prestandard Power over Ethernet concurrently. Cisco has also extended prestandard power management extensions using Cisco Discovery Protocol negotiation to Cisco IEEE 802.3af compliant devices to further optimize PSE power management.

To support Power over Ethernet delivery to power capable devices a number of issues need to be resolved. These issues are broadly outlined below:

1. Phone detection
2. Power delivery
3. Power management
4. Cable and Bandwidth management

It can be seen that although power delivery is a significant portion of supporting IP telephony, the overall performance from a systems perspective must be taken into account. This is important to bear in mind as IEEE 802.3af does not make any specific reference to how functions such as voice VLAN, QoS or bandwidth management are achieved, purely how power is applied to a wire.

Phone Detection

Applying Power over Ethernet requires that the device type be resolved to ensure that power is not applied to nonpower capable devices. To prevent unfortunate mishaps and to reduce the burden of network administration, Cisco and the IEEE devised mechanisms whereby the switch is able to determine whether a powered device or a nonpowered device is attached to a port. However, the phone detection mechanisms used by the Cisco prestandard Power over Ethernet implementation and IEEE802.3af are different in that the Cisco prestandard Power over Ethernet implementation uses AC powered device detection and IEEE 802.3af uses DC powered device detection. DC detection differs from AC detection in that AC detection transmits a low frequency AC signal and expects the same signal to be received back on the receive pair. DC detect applies a DC Current and detects the presence of a powered device by measuring the load applied by the powered device. It should be noted that Cisco IEEE 802.3af compliant devices support prestandard and IEEE 802.3af detection mechanisms.

Using a Cisco inline power capable switch or Power Sourcing Equipment (PSE), the switch port will send discovery signals on active and inactive Ethernet ports to detect whether a powered device is present or not. It should be remembered that the powered device will not be powered at this time and therefore cannot bring the link up. It is therefore necessary to transmit the discovery signal on a continuous basis as a powered device may be plugged into the port at anytime.



Figure 3
Cisco Powered Device Detection

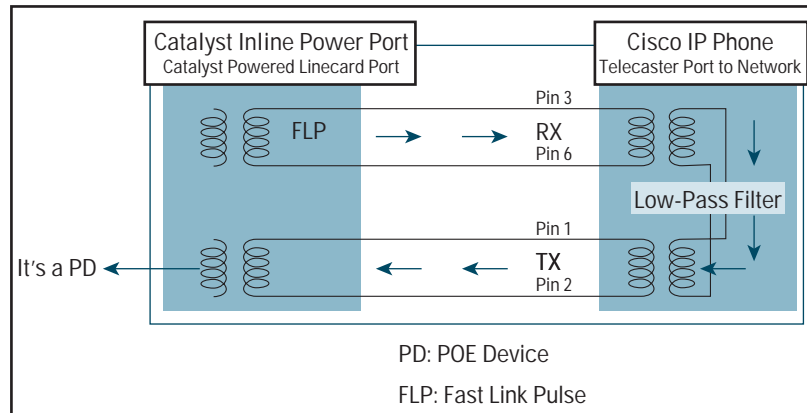

Within a Cisco prestandard powered device, a low pass filter that is connected between the powered devices receive and transmit pairs allows the low frequency discovery signal to loop back to the PSE. A low pass filter is used as it allows the phone discovery signal to loop back to the PSE, but prevents 10/100 or 1000Mbps frames from passing between the receive and transmit pairs. Once the PSE detects that a powered device is attached to the port, the Cisco PSE will apply power to the port.

By contrast, the IEEE 802.3af-2003 standard uses a different powered device detection technique that uses DC detection to determine whether a powered device is attached and to which power classification the device belongs. An IEEE 802.3af-2003 PSE achieves this by applying a DC voltage between the transmit and receive pairs and measuring either the received current (Amps) or voltage (V) received. A PSE will expect to see a 25K Ohm resistance between the pairs for the device to be considered a valid powered device. If the PSE does not detect a valid 25K Ohm resistor, power is not applied to the port.

Once a powered device has been discovered, an IEEE 802.3af PSE may optionally perform powered device classification by applying a DC voltage and current to the port. If the powered device supports optional power classification it will apply a load to the line to indicate to the PSE the classification the device requires by attenuating the DC voltage. The PSE then determines the powered device's classification using the Volt-Amp (VA) slope returned by the powered device's signature. If the powered device does not support classification, the powered device is assigned to Class 0, the default class.

Once the PSE has detected the powered devices IEEE 802.3af class, the PSE can manage the power allocation by subtracting the powered device's class maximum value from the overall power budget. If the value exceeds the available budget, power is not applied to the port. If the power is within the budget, power can be applied. The semantics of managing power budgets are vendor implementation specific.



Figure 4
Cisco IP Phone 7970G



A Cisco IEEE+CDP powered device, such as a Cisco IP phone 7970G, will come up in low power mode (6.3W) and will transmit a Cisco Discovery Protocol message with an inline power (ILP) type length value (TLV) that informs the PSE of the actual power required by the device. If the power is less than the default 15.4W, the PSE will acknowledge the request with its available power and modify the PSEs power budget. If the requesting powered device exceeds the power budget for the line card or switch, the port will be either powered down, or the port will remain in low power mode (7W).

This management scheme is implemented to provide backward compatibility and investment protection to the installed base of Cisco Catalyst prestandard Power over Ethernet capable line cards and switches. Cisco IP phones are power efficient and require 6.3W maximum power as reflected within the prestandard Power over Ethernet implementation. However, the development of new high-power powered devices, such as wireless access points and IP phones with color LCD screens require additional power that cannot be delivered using the prestandard implementations. By bringing up Cisco powered devices in low power mode, Cisco high power powered devices can operate, albeit with reduced functionality,² on prestandard line cards. Additionally, as Cisco powered devices explicitly signal to the PSE its exact power requirements, the PSE can accurately budget power consumption as only the power actually required by the powered device is allocated.

This management intelligence allows better power resource allocation in that powered devices can return unused power to the PSEs power budget. As an example, if an IEEE 802.3af Class 3 powered device requires 9W, the PSE must budget for the full 15.4W even though the device will only ever draw 9W. This wastes 6.4W per powered device that, if multiple 9W devices are present, wastes power budget that may prevent other lower power powered devices from being powered. By using Cisco Discovery Protocol to explicitly signal the actual power required, the wasted power is returned to the PSEs power budget.

2. The Cisco 7970G will operate as a telephone without the color screen and AP1200 will operate with a single aerial powered up.



Periodically, the PSE will check to see whether the powered device is still present and requires power and also implements checks to detect conditions such as where a short circuit may have been placed between transmit and receive pairs. Cisco implements two mechanisms to detect these conditions. The first is an extension of the prestandard discovery protocol whereby a discovery signal is transmitted periodically. If the received discovery signal has the same amplitude as the transmitted signal, the PSE will remove power, as there is a short circuit. If the PSE receives a discovery signal that has been attenuated by the low pass filter, the PSE will maintain power to the powered device. The second mechanism that is supported by Cisco is the IEEE 802.3af-2003 mechanism whereby the power draw is monitored and if it exceeds a specific value for a specific time period, power delivery is shut down to the port.

Power Classification

IEEE 802.3af-2003 describes five (5) power classes that a device may belong to. It should be noted that it is not mandatory that a PSE vendor implement power classification, as these classifications are optional. An important consideration when deploying a Power over Ethernet solution is how power is managed, and the resources, for example power draw, cooling, etc, that the solution requires to operate. If a vendor chooses not to implement power classification, the default power classification within IEEE 802.3af delivers 15.4W per power device that may require a network or facilities manager to invest in more power and cooling resources than a Cisco Power over Ethernet solution that implements intelligent power management. It should also be remembered that even though a powered device may support IEEE 802.3af-2003 power classification, the PSE may not, and 15.4Watt delivery is the lowest common denominator. Additionally, even if the PSE and powered device support power classification, the classification ranges are fairly broad that can lead to wasted power budget allocation. Refer to Table 1 for details of IEEE 802.3af-2003 power classes.

Table 1 IEEE 802.3af PSE and Powered Device Power Classifications

Class	Usage	Minimum Power Levels Output at the PSE	Maximum Power Levels at the Powered Device
0	Default	15.4W	0.44 to 12.95W
1	Optional	4.0W	0.44 to 3.84W
2	Optional	7.0W	3.84 to 6.49W
3	Optional	15.4W	6.49 to 12.95W
4	Reserved for Future Use	Treat as Class 0	Reserved for Future Use: A class 4 signature cannot be provided by a compliant powered device

If a powered device is classified as a Class 3 device, the PSE will allocate 15.4W to the device. However, if a Cisco Aironet 1200 Access Point, is being powered the device will draw only 8W (Table 3), whereby 7.4W is wasted within the PSE's power budget as the unused power cannot be returned to the power allocation pool.

Although the IEEE 802.3af classification appears to have redundant classes, specifically Class 0 and 3, this was an intentional decision made within the IEEE to allow inexpensive powered device detection circuits, i.e. a simple 25Kohm resistor implementation, as well as more sophisticated power classification circuitry to be incorporated into powered device design.



Power Disconnect

To prevent users from swapping patch lead connections between powered and nonpowered devices, a mechanism is required to detect that a powered device has been disconnected and power delivery withdrawn from the port before a nonpowered device can be attached. The IEEE 802.3af-2003 standard defines two mechanisms for disconnecting power once a device has failed. Both mechanisms provide a solution to protect against a user unplugging a powered device and plugging in a nonpowered device that would potentially damage the nonpower device. It should be remembered that although two mechanisms are described, they provide the same functionality albeit in a slightly different way. Cisco prestandard Power over Ethernet ports have a power disconnect mechanism that will remove power from the port if the Ethernet link status is down.

The Power Dilemma

The use of Power over Ethernet at the wiring closet creates a dilemma for network and facilities managers as each powered device draws a certain amount of power from the switch. This requires the switch to take into account not only the power required to operate the switch, but also the power required to drive the powered devices. This can have significant ramifications with respect to the power supply required to drive all the powered devices, how power is delivered within the switch, how the switch manages power allocation and finally for the power delivery requirements of the wiring closet (Figure 5).

Figure 5
Power Consumption Components

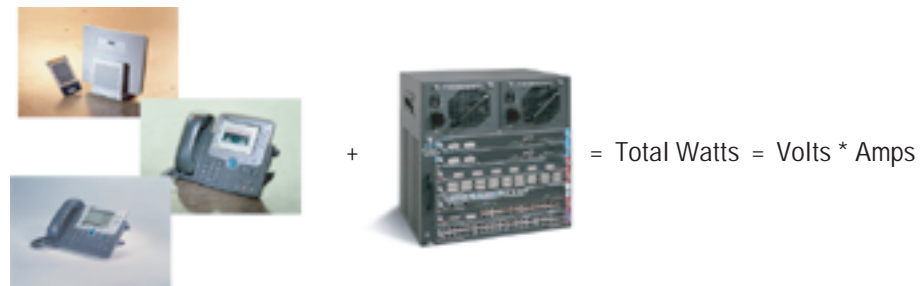

In a wiring closet scenario where, as an example, 240 powered devices may require to be supported, using the IEEE 802.3af-2003 default power class, each powered device would require 15.4W to be allocated whether the powered device actually requires that amount of power or not. This equates to 3696W for powered devices power only. As most modular switches generally require something in the order of 1000 to 2000W, the overall power budget for both the switch and powered devices is 5000 to 6000W.

This in turn introduces another problem for the facilities manager, as the power infrastructure must be able to support the power requirements for Power over Ethernet. Typically, a U.S. wiring closet will have an 110V/15Amp supply that can support up to 1650W.³ Although changes can be made to increase the AC power to the wiring closet by installing larger fuses, the power cabling may need to be upgraded with heavier gauge power cabling (8 or 10

3. Watts = Volts * Amps.



AWG cable). However, 110V can only support 30Amps maximum and as 3300Amps is insufficient to meet the requirements for delivering the required power to the wiring closet, a 220V 20Amps supply is required to be provisioned to each wiring closet.

Other considerations to be taken into account are how much cooling is now required within the wiring closet and whether uninterruptable power supplies (UPSs) will be required to ensure powered device operation should a power outage affect a wiring closet. These factors have significant cost implications if powered devices that require full 15.4W power delivery are to be supported.

The Cisco Catalyst switch portfolio offers support for a wide variety of AC and DC power supplies to support the required power loads. The DC power supplies can be powered from either a central battery or external power shelves. This allows a user to implement a power delivery scheme that is equivalent to that used within public telephone exchanges, such as central battery operation with diesel generator backup, that provides the same high power availability characteristics seen within public telephone exchanges.

Cisco Intelligent Power Management

Delivery of Power over Ethernet using the IEEE 802.3af default classification may significantly increase the power requirements on both the PSE switch and the power infrastructure. To provide Power over Ethernet in a cost effective and efficient manner, Cisco Catalyst switches support intelligent power management in addition to IEEE 802.3af classification. This enables a powered device and PSE negotiate their respective capabilities to explicitly manage how much power is required to power the device and also how the PSE capable switch manages the allocation of power to individual powered devices. These IPM capabilities allow a network and facilities manager to effectively and economically manage the power resources within a wiring closet and PSE capable switches to meet the objectives of the network.

The Amount of Power Required

A Cisco IP Phone 7960G requires 7W when the phone is ringing at maximum volume and requires 5W on or off hook. This is a significant reduction from the 15.4W maximum power allowed for within IEEE 802.3af-2003. It can be seen that PSE power requirements can be significantly reduced by budgeting for the power the device actually requires, rather than simply allocating the maximum power defined within IEEE 802.3af.

If a Cisco Power over Ethernet installation is considered, it may be assumed that 20 percent of phones will be in active usage and 10% actively ringing at any single point, and the power requirements can be calculated as:

- $240 * .8 * 5.0W = 960W$
- $240 * .2 * 7.0W = 168W$
- Total = 1128W

It can be seen that the average amount of power required to deliver Power over Ethernet is generally less than the maximum budgeted, as a powered device will typically draw less power when in a quiescent state. Although it is feasible to manage power using this method, in practice managing power budgets using averages can cause problems if, for example, all telephones rang simultaneously. It should be noted that this event would be very unlikely.

To simplify operations and achieve better power management, Cisco has taken a conservative approach to allocation of power whereby the PSE will allocate either the IEEE 802.3af class, the negotiated Cisco Discovery Protocol value, or 7W per powered device, depending upon the discovered device. If the default value, 7W, for 240 Cisco 7960G is



assumed, this will equate to 1680W. If the power requirements for the switch are added (supervisors, line cards, etc.) the power requirements for the above configuration can be accommodated by a 2,500Watt or 4,000Watt supply. However, although it is feasible to provide large enough supplies to manage maximum power load for all powered devices, most Ethernet PSEs are not able to support a fully redundant powered device load even if Class 2 powered devices are connected. This may be due to a variety of factors such as using existing PSE PSUs or wiring closet power availability, i.e. 110V at 15Amps.

Cisco has long experience in managing Power over Ethernet that has led to the development of several power management strategies and features that allow multiple powered devices to be connected to a single switch even though the total power required by the powered devices may exceed the power available from a single PSU. To address this, Cisco supports delivering power using a combination of two lower wattage PSUs rather than load sharing, which is the typical operation for redundant PSUs. This allows a network manager flexibility if a wiring closet has 110V power.

Cisco Catalyst switches, by default, allocate 7W per port that in dense telephone environments may be inefficient in terms of the number of powered devices that can be powered. To allow greater flexibility, Cisco IOS[®] Software allows this value to be overridden by a network manager to a nominal per port power value that is used by the IPM for power budgeting purposes. By defining a lower port power value, IPM subtracts the configured value from the power budget, instead of the default 7W, IEEE 802.3af-2003 class, or Cisco Discovery Protocol negotiated value. If power is not being drawn, the configured power budget is returned to the PSEs overall power budget. Although a powered device may still draw more than the configured value, from a power management perspective the powered devices configured power draw is subtracted not the peak value. It should be noted that even though a powered device is allocated a maximum power value: that is 7W, its actual consumption is generally a lot less, and consequently some over-subscription may be acceptable in certain environments. This does however require that the network manager has a good understanding of telephone usage and call volumes, but can provide solutions where power delivery is limited.

Cisco IPM also provides explicit negotiation of power capabilities between a Cisco powered device, such as a Cisco Aironet 1200 Access Point, and the Cisco Catalyst PSE switch using Cisco Discovery Protocol. This provides unique capabilities as it allows the powered device to power up in low power mode and then move to high power once the switch has negotiated it can support the higher power requirements.

If the switch port cannot support the requested power, the powered device can operate in low power mode, albeit with some reduced functionality. As an example, a Cisco Aironet 1200 Access Point will only power a single antennae if 7W is available. This is useful in environments where Cisco prestandard Power over Ethernet line cards are deployed that cannot deliver more than 7W, but may be required to support new high power devices for an interim period.



Figure 6
Cisco Aironet 1200 Access Point



Cisco has also extended the concept of intelligent power management to IEEE 802.3af devices to better manage power resources within the switch. As an example a Cisco Aironet 1200 Access Point requires 8W for normal operation (Table 3), but is classified as a Class 3 device that has a class maximum of 15.4W. To provide more granular power management, Cisco supports the concept of power negotiation using Cisco Discovery Protocol (CDP) between a Cisco PSE and Cisco powered devices such that unused power can be returned to the Cisco PSE IPM budget. Using a Cisco Aironet 1200 Access Point, by explicitly negotiating that it only requires 8W instead of the Class 3 maximum of 15.4W, 7.4W is returned to the PSEs power budget thereby providing better power management granularity than the power classifications described within IEEE 802.3af-2003.

Table 2 Wireless Access Point Power Requirements

Cisco Wireless Access Point	Power Required
AP1100	4.9W
APW/ 802.11a	8W
AP1200/802.11b	6W
AP1200/802.11a/b	11W
AP340/350	<5W

To refine and protect the switch in the case of devices drawing too much power, each Catalyst port may be assigned a maximum power delivery. If a Cisco Discovery Protocol capable powered device is connected and the requested power is too great, the PSE may inform the powered device of the ports configured power value and the powered device may remain in low power mode. If an IEEE 802.3af powered device is attached, the port will not be powered if the powered devices power classification exceeds the maximum power.



Figure 7
Sony SNC Z20N Network Camera



Cisco also supports the capability to assign priority status to a port. By default all Cisco Power over Ethernet capable ports are configured as “auto,” whereby when a port comes up, the PSEs IPM checks that there is enough budget for power to be applied to the port. If a port is configured as a priority port, the power budget for the port is automatically subtracted from the IPMs power budget, even if the port is not active. As the power is preallocated, the powered device attached to that port is assured power delivery. This allows a network manager to preallocate power to priority powered devices such as wireless-powered devices and critical user phones to ensure these powered devices are preferentially powered.

In some cases lower power PSUs can be used that when combined provide enough power to run all powered devices allocated within the system. By implementing power priority status and combined power delivery, the PSE can elegantly recover from a PSU failure. In the event of a PSU failure a decision can be made to only power specific devices. In the case where one of the load-sharing PSUs were to fail, the systems integral Intelligent Power Manager can detect this and may intelligently withdraw power from powered devices that are low priority to maintain it’s overall power budget integrity.

If it is required to provide power to all powered devices in the event that a PSU fails, larger 4000W PSUs and 220V power supplies will need to be provisioned with a 20Amps fuse. However, what can be seen is that if the power is intelligently managed, the overall burden on power resources can be reduced.

Although the wiring closet power requirements have been touched upon, one aspect that is directly related to power redundancy is whether to provide UPS services to the wiring closets. This can incur a significant cost that may be reduced using the Cisco Intelligent Power Management and by assigning priorities to user phones.

Summary

With the delivery of IEEE 802.3af Power over Ethernet Cisco have extended their leadership in Power over Ethernet capability with a comprehensive portfolio of 10/100/1000BASE-T Ethernet interfaces for the Cisco Catalyst 3500, 4500 and 6500 while providing backward compatibility with existing Cisco prestandard Power over Ethernet line cards. By delivering standards based Power over Ethernet over 10/100 and 1000BASE-T that is backward compatible with existing line cards, Cisco provides a platform whereby an enterprise that makes an investment in 10/100/1000 technology can use next generation hardware and applications to derive competitive advantage as well as future proof the network for the foreseeable future.

Although IEEE 802.3af is an important development, Cisco has innovated complementary technology to the IEEE 802.3af standard with IPM that intelligently manages the power resources within a PSE device such that a variety of power delivery options are available to the network manager. This is important to facilities and network managers as the IEEE 802.3af standard does not describe how power is managed within a PSE or how a PSE and powered device may negotiate granular power parameters based upon actual power requirements and capabilities. Additionally Cisco has pioneered features such as Voice VLAN and quality of service (QoS) mechanisms that enable packet telephony to work efficiently across switched Ethernet infrastructures.

Cisco IPM also provides options for situations where the wiring closet is constrained by the AC power delivery infrastructure, or where PSE power is limited. Cisco also supports DC power delivery

for installations where highly available power delivery is critical and where an investment in DC power infrastructure is considered to be a business benefit.

Cisco has shipped more than 16 million Power over Ethernet-enabled ports that makes Cisco the market leader in delivering and managing Power over Ethernet solutions. The ratification of the IEEE 802.3af standard and the support of PSE functionality by Cisco Systems in the Catalyst 3500, 3650, 4500 and 6500 series multiservice switches and powered device capabilities in Cisco devices such as the Cisco IP Phone 7960G, Cisco IP Phone 7970G, and Cisco IEEE 802.11 wireless access points further extends leadership by Cisco Systems in the deployment and management of Power over Ethernet solutions such as IP Telephony and IP video surveillance.



Corporate Headquarters
Cisco Systems, Inc.
170 West Tasman Drive
San Jose, CA 95134-1706
USA
www.cisco.com
Tel: 408 526-4000
800 553-NETS (6387)
Fax: 408 526-4100

European Headquarters
Cisco Systems International BV
Haarlerbergpark
Haarlerbergweg 13-19
1101 CH Amsterdam
The Netherlands
www-europe.cisco.com
Tel: 31 0 20 357 1000
Fax: 31 0 20 357 1100

Americas Headquarters
Cisco Systems, Inc.
170 West Tasman Drive
San Jose, CA 95134-1706
USA
www.cisco.com
Tel: 408 526-7660
Fax: 408 527-0883

Asia Pacific Headquarters
Cisco Systems, Inc.
168 Robinson Road
#28-01 Capital Tower
Singapore 068912
www.cisco.com
Tel: +65 6317 7777
Fax: +65 6317 7799

Cisco Systems has more than 200 offices in the following countries and regions. Addresses, phone numbers, and fax numbers are listed on the Cisco Web site at www.cisco.com/go/offices

Argentina • Australia • Austria • Belgium • Brazil • Bulgaria • Canada • Chile • China PRC • Colombia • Costa Rica • Croatia • Czech Republic • Denmark • Dubai, UAE • Finland • France • Germany • Greece • Hong Kong SAR • Hungary • India • Indonesia • Ireland • Israel • Italy • Japan • Korea • Luxembourg • Malaysia • Mexico • The Netherlands • New Zealand • Norway • Peru • Philippines • Poland • Portugal • Puerto Rico • Romania • Russia • Saudi Arabia • Scotland • Singapore • Slovakia • Slovenia • South Africa • Spain • Sweden • Switzerland • Taiwan • Thailand • Turkey • Ukraine • United Kingdom • United States • Venezuela • Vietnam • Zimbabwe

All contents are Copyright © 1992–2004 Cisco Systems, Inc. All rights reserved. Cisco, Cisco Systems, the Cisco Systems logo, Aironet, Catalyst, and Cisco IOS are registered trademarks or trademarks of Cisco Systems, Inc. and/or its affiliates in the U.S. and certain other countries.

All other trademarks mentioned in this document or Web site are the property of their respective owners. The use of the word partner does not imply a partnership relationship between Cisco and any other company. (0304R) ETMG 203190—JR 04/04